

# Electromagnetic corrections in hadron scattering, with application to N N

Autor(en): **Tromborg, B. / Waldenstrøm, S. / Øverbø, I.**

Objektyp: **Article**

Zeitschrift: **Helvetica Physica Acta**

Band (Jahr): **51 (1978)**

Heft 4

PDF erstellt am: **22.09.2024**

Persistenter Link: <https://doi.org/10.5169/seals-114961>

## **Nutzungsbedingungen**

Die ETH-Bibliothek ist Anbieterin der digitalisierten Zeitschriften. Sie besitzt keine Urheberrechte an den Inhalten der Zeitschriften. Die Rechte liegen in der Regel bei den Herausgebern. Die auf der Plattform e-periodica veröffentlichten Dokumente stehen für nicht-kommerzielle Zwecke in Lehre und Forschung sowie für die private Nutzung frei zur Verfügung. Einzelne Dateien oder Ausdrucke aus diesem Angebot können zusammen mit diesen Nutzungsbedingungen und den korrekten Herkunftsbezeichnungen weitergegeben werden. Das Veröffentlichen von Bildern in Print- und Online-Publikationen ist nur mit vorheriger Genehmigung der Rechteinhaber erlaubt. Die systematische Speicherung von Teilen des elektronischen Angebots auf anderen Servern bedarf ebenfalls des schriftlichen Einverständnisses der Rechteinhaber.

## **Haftungsausschluss**

Alle Angaben erfolgen ohne Gewähr für Vollständigkeit oder Richtigkeit. Es wird keine Haftung übernommen für Schäden durch die Verwendung von Informationen aus diesem Online-Angebot oder durch das Fehlen von Informationen. Dies gilt auch für Inhalte Dritter, die über dieses Angebot zugänglich sind.

# Electromagnetic corrections in hadron scattering, with application to $\pi N \rightarrow \pi N$

by **B. Tromborg**

The Niels Bohr Institute, University of Copenhagen, DK-2100 Copenhagen Ø, Denmark

and **S. Waldenstrøm** and **I. Øverbø**

Institute of Physics, University of Trondheim, NLHT, N-7000 Trondheim, Norway

(28. II. 1978; rev. 18. V. 1978)

*Abstract.* A general dispersion relation method for calculating electromagnetic corrections to hadron scattering is presented. An application is made to  $\pi N$  scattering, for which the electromagnetic corrections to the  $S$ - and  $P$ -wave phase shifts and inelasticities in  $\pi^- p$  elastic and charge exchange scattering are calculated. For the  $P_{33}$  resonance the corrections obtained correspond to a width difference  $\Gamma_{\Delta^{++}} - \Gamma_{\Delta^0} \simeq -5 \text{ MeV}/c^2$  and a mass difference  $M_{\Delta^{++}} - M_{\Delta^0} \simeq 1 \text{ MeV}/c^2$ . The inelasticity corrections are derived directly from the unitarity relation, and are for  $\pi^- p$  scattering mainly due to the  $n\gamma$ -channel. The contributions from bremsstrahlung are negligible, as has recently been demonstrated also for  $\pi^+ p$  scattering.

## 1. Introduction

It is well known that the nuclear amplitude  $F_N$ , obtained from a hadron scattering experiment after subtraction of Coulomb scattering and Coulomb-nuclear interference terms, still contains a trace of electromagnetic (e.m.) interactions. That is,  $F_N$  differs from what one would like to think of as the purely hadronic amplitude  $F_H$ . The general goal of the present paper is to determine the e.m. correction

$$\delta F = F_N - F_H \tag{1.1}$$

applying quantum electrodynamics, but trying to use as few assumptions as possible about the strong interaction.

In previous work on e.m. corrections [1–4] we defined  $F_H$  to be the amplitude  $F_N$  in the limit of no e.m. interactions. However, without a combined theory for the strong and e.m. interactions we have no prescription for taking this limit. This definition therefore is almost empty; it merely serves to illustrate what we are after.

It seems reasonable to assume that  $F_H$  obeys SU(2) and unitarity in the space of pure hadronic states (i.e., states with no photons). We also assume that it obeys crossing and is analytic with only the hadronic unitarity cuts. The problem is that we have to specify the masses and coupling constants that appear in  $F_H$ . These should ideally be the physical masses and coupling constants in the limit of no e.m. interactions, but again this limit cannot be taken. Instead we simply choose a particle mass

for each iso-multiplet to represent the pure hadronic mass, and similarly for the coupling constants. This means that the amplitude  $F_H$  derived from (1.1) will not strictly speaking be a pure hadronic amplitude but rather a *standard* amplitude with simple analyticity and unitarity properties.

There is no experimental way of verifying the actual choice of masses and coupling constants. Thus it is not possible to measure the individual corrections, but only combinations of them in which the dependence on  $F_H$  cancels to first order. To find which combinations of corrections are measurable one has to form all the combinations of measurable quantities that would be zero if SU(2) were exact. In  $\pi N$  scattering we have, e.g.

$$F_N(\pi^+ p \rightarrow \pi^+ p) - F_N(\pi^- p \rightarrow \pi^- p) - \sqrt{2} F_N(\pi^- p \rightarrow \pi^0 n), \tag{1.2}$$

$$\Gamma(\Delta^0 \rightarrow \pi^- p) / \Gamma(\Delta^0 \rightarrow \pi^0 n) - \frac{1}{2}, \tag{1.3}$$

and

$$\delta^+(P_{33}) - \delta^-(P_{33}), \tag{1.4}$$

where  $\delta^+$  and  $\delta^-$  are the  $P_{33}$  nuclear phase shifts derived from  $\pi^+ p$  and  $\pi^- p$  scattering respectively. With our assumption of SU(2) for  $F_H$  these expressions are all given in terms of combinations of corrections.

What we have said means that the ambiguity in the masses and coupling constants to be used in  $F_H$  is no obstacle to an experimental check of charge independence of strong interactions.

From the analyticity and unitarity properties of  $F_N$  and  $F_H$  one can derive a dispersion relation for  $\delta F$  as was first shown by Dashen and Frautschi [5]. The form of the dispersion relation is not unique and in fact many different forms have been used [1–6]. In the present paper we shall use the method of Ref. [4], suitably extended to include the multichannel case. The extension of the method is described in Section 2.

In Section 3 the method is applied to calculate the corrections to  $\pi N$  scattering. The phase shift corrections are given by a kind of partial wave dispersion relation. It is convenient to divide the contributions to the corrections into five categories, namely, (i) Coulomb corrections due to Coulomb scattering of the external particles, (ii) corrections due to the mass differences  $M_{\pi^+} - M_{\pi^0}$  and  $M_p - M_n$ , (iii) corrections due to differences between the  $\pi^- pn$ ,  $\pi^0 pp$ , and  $\pi^0 nn$  coupling constants, (iv) contributions from the  $n\gamma$ -channel in  $\pi^- p$  scattering, and (v) short range contributions.

The terms (i)–(iv) contain dispersion integrals over the physical cut and the long range part of the left-hand cut. They are essentially given in terms of measurable quantities and can be calculated directly. Our results for (i) are roughly in agreement with Bugg's results [7, 8] obtained from a relativistic potential model. The problem of determining the mass difference effects from potential theory has been discussed in detail by Oades and Rasche, Rasche and Woolcock, and by Zimmermann [9, 10]. Numerical results for the corrections were obtained by Zimmermann from a phase shift analysis, where the corrections were determined so as to give charge independent phase shifts. The corrections obtained by this method are sort of effective corrections and it is not clear (to us) how they should be compared to our results.

The differences between the various  $\pi NN$  coupling constants are unknown, and hence also the contributions (iii). In Figures 2–4 we show what the contributions would be for coupling constant differences of the order 1%. The  $n\gamma$  contribution (iv) can be calculated directly from the known photoproduction amplitudes.

There remains, however, the term (v) coming from the short range part of the left-hand cut integral. We are not able to determine or even estimate this term, which is of course a serious drawback of our method. However, the short range contribution to the dispersion integral is supposed to vary slowly in the low and medium energy region, i.e., up to energies well above the  $P_{33}$  resonance. This means that the energy dependence of the short range contribution is more or less known.

In Section 3.3 we derive the expression for (1.3) and give its value in the absence of short range effects. In Section 3.4 we discuss the differences in mass and width of the  $\Delta^{++}$  and  $\Delta^0$  resonances.

The inelasticity corrections can be derived directly from the unitarity equation. They are therefore not subject to uncertainty due to short range e.m. effects or to mass and coupling constant ambiguities. The inelasticity correction to  $\pi^+p$  scattering is due to bremsstrahlung and was calculated in Ref. [4], where we found very small values. In  $\pi^-p$  scattering the main contribution comes from the  $n\gamma$ -channel and is calculated from the known photoproduction amplitudes. We also estimate the bremsstrahlung contribution and find it negligible in the considered energy range (cf. Section 3.1).

Our e.m. corrections might be particularly useful in the type of data analysis where analyticity and unitarity are imposed as constraints on the scattering amplitude. In such an analysis the data should be corrected not only for Coulomb scattering and Coulomb-nuclear interference but also for the e.m. corrections (1.1). (A detailed discussion of how to do this is given in Ref. [11].) This will ensure that the corrected data are consistent with the simple analyticity and unitarity properties assumed for the pure hadronic amplitude.

Since our corrections do not include all short range e.m. effects one cannot expect the output of the analysis to be a charge independent amplitude. One must therefore in the analysis distinguish between the isospin 3/2 amplitudes in  $\pi^+p$  and  $\pi^-p$  scattering.

With this method it is obviously not possible to *verify* charge independence. However, it should be noticed that the difference between the two amplitudes must have a specific energy dependence in order to be *consistent with* charge independence, namely that corresponding to smooth (short range) contributions to the dispersion integrals.

## 2. General method

We consider the two-body reactions

$$A_\mu + B_\mu \rightarrow A_\nu + B_\nu, \quad (\mu, \nu = 1, \dots, N), \quad (2.1)$$

where  $A, B$  are hadrons, and assume that no other purely hadronic channels are important. (There may in addition be radiative channels such as hadron(s) + photon(s).) In the outline of the method we assume for simplicity  $A, B$  to be spinless. The  $S$ -matrix describing (2.1) is denoted by  $S_{CH\lambda}$ , where C and H indicate Coulomb and hadronic, and  $\lambda$  is the photon mass.

If there are charged particles in the channels  $\mu$  or  $\nu$ , the matrix element  $(S_{CH\lambda})_{\mu\nu}$  is zero in the limit  $\lambda \rightarrow 0$ . This is because an accelerated charged particle always emits zero mass photons. Therefore there is no purely hadronic scattering in the zero mass limit. The  $\lambda$ -dependence of  $S_{CH\lambda}$  is for small  $\lambda$  given by the simple form



$$(S_{\text{CH}\lambda})_{\mu\nu} = O(1) \exp(-L_{\mu\nu} \ln \lambda), \quad (2.2)$$

where  $L_{\mu\nu}$  is a known function of the Mandelstam variables  $s, t, u$  (see Appendix A). This enables us to form a finite  $\lambda$ -independent  $S$ -matrix  $\bar{S}_{\text{CH}}$  by the construction

$$(\bar{S}_{\text{CH}})_{\mu\nu} = \lim_{\lambda \rightarrow 0} D_{\mu\nu}(S_{\text{CH}\lambda})_{\mu\nu}, \quad (2.3)$$

where  $D_{\mu\nu}$  is a suitably chosen function containing the factor  $\exp(L_{\mu\nu} \ln \lambda)$ . The precise definition of  $D_{\mu\nu}$  is given in Appendix A.

We define a Coulomb  $S$ -matrix  $S_{\text{C}\lambda}$  by

$$S_{\text{C}\lambda} = 4\pi\delta(\omega) + 2iq^{1/2}f_{\text{C}\lambda}q^{1/2}, \quad (2.4)$$

where  $f_{\text{C}\lambda}$  is the Coulomb amplitude, defined as the sum of all Feynman graphs where only photons are exchanged. Also,  $q = \text{diag}(q_1, \dots, q_N)$ , where  $q_\mu$  is the c.m. momentum in the  $\mu$ -channel. Analogous to (2.3) we define a finite Coulomb  $S$ -matrix  $\bar{S}_{\text{C}}$  by

$$(\bar{S}_{\text{C}})_{\mu\nu} = \lim_{\lambda \rightarrow 0} D_{\mu\nu}(S_{\text{C}\lambda})_{\mu\nu}. \quad (2.5)$$

The definition of  $D_{\mu\nu}$  given in Appendix A looks rather complicated but as argued in Refs. [4] and [2] it is nevertheless almost canonical. With this definition the amplitude

$$\bar{f} = \frac{1}{2i} q^{-1/2} (\bar{S}_{\text{CH}} - \bar{S}_{\text{C}}) q^{-1/2} \quad (2.6)$$

has a number of useful properties [4]. It obeys crossing, and it has the same analytic structure as assumed for the pure hadronic amplitude except for the unitarity cuts coming from intermediate states of the type hadron(s) + photon(s). (We shall call these states radiative states and their unitarity cuts radiative cuts.) The graphs with intermediate states of photons only have explicitly been removed by the construction of  $\bar{f}$ . Due to mass splittings within SU(2) multiplets the hadronic cuts in  $\bar{f}$  are usually shifted a little compared to the corresponding cuts in the pure hadronic amplitude. At the thresholds in the  $s$ -,  $t$ -, and  $u$ -channels there may be essential singularities due to the accumulation of Coulomb bound or antibound state poles. However,  $\bar{f}$  is finite at the thresholds on the physical sheet and it obeys simple fixed  $s$  and  $t$  dispersion relations. Another consequence of our choice of  $D_{\mu\nu}$  is that the inelasticity corrections due to bremsstrahlung become small in the low and medium energy region. Furthermore the introduction of e.m. form factors in  $D_{\mu\nu}$  implies that the phase shift corrections approach zero more rapidly with increasing energy. The reason for this is that form factors tend to reduce the short range e.m. effects.

### 2.1. Coulomb phase shifts

We assume for simplicity that  $S_{\text{C}\lambda}$  is diagonal, which is anyway the usual case. The definition (above the corresponding threshold) of the  $\mu$ -channel Coulomb phase shift  $\Sigma_{l,\mu}$  is based on the partial wave projection of  $(\bar{S}_{\text{C}})_{\mu\mu}$ :<sup>1)</sup>

<sup>1)</sup> For the partial wave projection of a quantity  $f$  we use the symbol  $(f)_l$ ,  $l$  being the orbital angular momentum. In many cases where the meaning should be clear the label  $l$  is omitted.

$$(\bar{S}_C)_{\mu\mu,l} \equiv |D_{\mu\mu}(s, t = 0)| \exp(2i\Sigma_{l,\mu}). \quad (2.7)$$

It follows from equations (2.4) and (2.7) that to order  $\alpha$ ,

$$(f_{C\lambda}^B)_{\mu\mu,l} = (\frac{1}{2}\psi_{\mu\mu} + \Sigma_{l,\mu})/q_\mu, \quad (2.8)$$

where  $f_{C\lambda}^B$  is the one-photon exchange amplitude and  $(-\psi_{\mu\mu})$  is the phase of  $D_{\mu\mu}$  (cf. Appendix A). For point charges,  $\Sigma_l$  is in the non-relativistic limit equal to  $\sigma_l - \sigma_0$ , where

$$\sigma_l = \arg \Gamma(1 + l + i\gamma), \quad (2.9)$$

and  $\gamma$  is the Coulomb parameter

$$\gamma = Z_1 Z_2 \alpha/v, \quad (2.10)$$

$Z_1$  and  $Z_2$  being the charges of  $A_\mu$ ,  $B_\mu$ , and  $v$  being the lab relative velocity.

## 2.2. The nuclear S-matrix

From the finite S-matrices  $\bar{S}_{CH}$  and  $\bar{S}_C$  we define a nuclear S-matrix  $S_N$  by

$$(\bar{S}_{CH})_l = (\bar{S}_C)_l^{1/2} (S_N)_l (\bar{S}_C)_l^{1/2}. \quad (2.11)$$

This definition is consistent with the usual definition of a nuclear S-matrix (cf. equation (1.21) of Ref. [12]). It ensures that  $S_N$  is symmetric.

From the S-matrices we form the reduced partial wave amplitudes

$$F_N = \frac{1}{2i} Q^{-1/2} ((S_N)_l - 1) Q^{-1/2}, \quad (2.12)$$

$$F = q^{-l} (f)_{\mu\mu} q^{-l} = (\bar{S}_C)_l^{1/2} F_N (\bar{S}_C)_l^{1/2}, \quad (2.13)$$

$$F_H = \frac{1}{2i} Q_H^{-1/2} ((S_H)_l - 1) Q_H^{-1/2}, \quad (2.14)$$

where  $S_H$  is the pure hadronic S-matrix and  $Q$ ,  $Q_H$  are diagonal matrices with

$$Q_{\mu\mu} = q_\mu^{2l+1}, \quad (Q_H)_{\mu\mu} = (q_H)_\mu^{2l+1}, \quad (2.15)$$

$q_\mu$ ,  $(q_H)_\mu$  being the c.m. momenta in the  $\mu$ -channel.

For  $q_\mu$  we have the kinematic relation

$$4sq_\mu^2(s) = (s - (m_A + m_B)^2)(s - (m_A - m_B)^2), \quad (2.16)$$

where  $m_A$ ,  $m_B$  are the masses of  $A_\mu$ ,  $B_\mu$ . The same relation gives  $q_H$ . Ideally,  $m_A$ ,  $m_B$  should then be the masses of  $A_\mu$ ,  $B_\mu$  in the limit of no e.m. interactions. As discussed in the introduction, however, these masses are unknown. For each isospin multiplet we shall therefore *choose* a mass to represent the pure hadronic mass. Our e.m. corrections will then be determined relative to these standard masses.

## 2.3. Dispersion relation for the e.m. correction

As stated in the introduction, our problem is to determine the e.m. correction

$\delta F = F_N - F_H$ . We shall see that an equation for  $\delta F$  can be obtained by the use of unitarity and analyticity.

Since  $f$  with a few exceptions has the same analytic structure as assumed for the pure hadronic amplitude, it follows that the reduced partial wave amplitude  $F$  has the same analytic structure as  $F_H$ . In the  $s$ -plane,  $F_H$  has the so-called physical (or right-hand) cut singularity  $s_0 \leq s \leq \infty$ , where  $s_0$  is the lowest threshold of all the channels. There is also a left-hand cut due to particle exchange in the  $t$ - and  $u$ -channels and this cut can have a quite complicated structure [13].

On the physical cut the unitarity equation for  $F_H$  has the simple form

$$\text{Im } F_H^{-1} = -Q_H P, \quad (2.17)$$

where  $P$  is the projection onto the set of open channels. In the next section we shall see that unitarity also gives an explicit expression for  $\text{Im } F^{-1}$  on the physical cut.

To first order,

$$\text{Im } F^{-1} - \text{Im } F_H^{-1} = -\text{Im } [F_H^{-1}(F - F_H)F_H^{-1}]. \quad (2.18)$$

Using the  $N/D$  representation

$$F_H = \mathcal{N} \mathcal{D}^{-1} \quad (2.19)$$

we can write (2.18) as

$$\text{Im } \mathcal{H} = -\mathcal{N}^T (\text{Im } F^{-1} - \text{Im } F_H^{-1}) \mathcal{N}, \quad s_0 \leq s \leq \infty, \quad (2.20)$$

where

$$\mathcal{H} \equiv \mathcal{D}^T (F - F_H) \mathcal{D}. \quad (2.21)$$

In deriving (2.20) we have used the facts that  $F_H$  is symmetric and  $\mathcal{N}$  is real on the physical cut [5].

The function  $\mathcal{H}$  has the same analytic structure as  $F$ . Therefore it obeys a dispersion relation of the form

$$\mathcal{H}(s) = \frac{1}{2\pi i} \int_{\text{l.h.c.}} \frac{\Delta \mathcal{H}(s')}{s' - s} ds' + \frac{1}{\pi} \int_{s_0}^{\infty} \frac{\text{Im } \mathcal{H}(s' +)}{s' - s} ds', \quad (2.22)$$

where the first integral is over the left-hand cut (l.h.c.) and the second is over the physical cut. From (2.20) we see that unitarity gives  $\text{Im } \mathcal{H}$  on the physical cut. This determines the physical cut integral in (2.22). In many cases one can also determine the long range part of the l.h.c. integral. This means that the unknown part of  $\mathcal{H}(s)$  is only the short (and medium) range part of the l.h.c. integral. This part may be assumed to be small or at least to have very little structure in the physical region.

By (2.12)–(2.14), (1.1), and (2.21) we have to first order

$$\mathcal{H} = \mathcal{D}^T \mathcal{C} \mathcal{N} + \mathcal{N}^T \mathcal{C} \mathcal{D} + \mathcal{D}^T \delta F \mathcal{D}, \quad (2.23)$$

where

$$\mathcal{C} \equiv (\bar{S}_C)_l^{1/2} - 1. \quad (2.24)$$

The matrix  $\mathcal{C}$  is known to order  $\alpha$  from the one-photon exchange amplitude and the factors  $D_{\mu\mu}$ . Therefore, knowing  $\mathcal{H}$ , one can finally solve (2.23) for  $\delta F$ .

#### 2.4. The $\lambda$ -independent unitarity relation

We shall now see how unitarity gives  $\text{Im } F^{-1}$  on the physical cut.

In analogy with (2.4) we define an amplitude  $f$  corresponding to the  $S$ -matrix  $S_{\text{CH}\lambda}$ . The unitarity relation for  $f$  can symbolically be written as

$$\text{Im } f = f^\dagger q P f + S^\dagger P_s S + S^\dagger P_h S, \quad (2.25)$$

$S$  being the suitably normalized  $S$ -matrix. Again  $P$  is the projection onto the open hadronic channels, and  $P_s$  is the projection onto the open bremsstrahlung channels

$$A_\kappa + B_\kappa + \text{photons},$$

where the photons in the overall c.m. system have a total energy less than  $E$ . This energy is chosen such that the soft photon approximation can be used for these photons. The projection  $P_h$  is onto the open states of hard photon bremsstrahlung and any other possible radiative states. (An example of the latter is the  $n\gamma$ -channel in  $\pi^-p$  scattering.) The hard photon term  $S^\dagger P_h S$  is infrared convergent to order  $\alpha$ .

Using the soft photon approximation one can write (2.25) more explicitly as (cf. Ref. [2], Section 7 for details)

$$\text{Im } f_{\mu\nu}(\theta) = \sum_\kappa \frac{1}{4\pi} \int f_{\kappa\mu}^*(\theta'') q_\kappa f_{\kappa\nu}(\theta') \left(\frac{2E}{\lambda}\right)^{A'_{\kappa\mu} + A'_{\kappa\nu} - A_{\mu\nu}} d\omega' + \text{h.p.}, \quad (2.26)$$

where h.p. is shorthand for the hard photon term. As usual  $\omega' = (\theta', \varphi')$  and  $\omega = (\theta, 0)$  give the c.m. directions of the intermediate and final state particles and  $\theta''$  is the angle between these directions. Also,

$$A'_{\kappa\nu} = -\text{Re } L_{\kappa\nu}(\theta'), \quad A''_{\kappa\mu} = -\text{Re } L_{\kappa\mu}(\theta''), \quad \text{and} \quad A_{\mu\nu} = -\text{Re } L_{\mu\nu}(\theta), \quad (2.27)$$

where  $L_{\mu\nu}$  is given in Appendix A.

By (2.4) and (2.6) we have

$$f_{\mu\nu} = (f_{\text{C}\lambda})_{\mu\nu} + \bar{f}_{\mu\nu}/D_{\mu\nu}. \quad (2.28)$$

The phase  $\psi_{\mu\nu}$ , defined by

$$D_{\mu\nu} = |D_{\mu\nu}| \exp(-i\psi_{\mu\nu}), \quad (2.29)$$

depends only on  $s$ , and (cf. Appendix A)

$$\psi_{\mu\nu} = \frac{1}{2}(\psi_{\mu\mu} + \psi_{\nu\nu}). \quad (2.30)$$

The phase  $\psi_{\mu\mu}$  is zero below the threshold of the  $\mu$ -channel.

We now insert (2.8), (2.28), and (2.29) into (2.26) and find to order  $\alpha$  the following unitarity relation for the reduced partial waves:

$$\begin{aligned} \text{Im } (\tilde{F}_{\mu\nu} e^{i\psi_{\mu\nu}}) &= \left(\frac{1}{2}\psi_{\mu\mu} + \Sigma_{l,\mu}\right) (F_{\text{H}})_{\mu\nu} P_{\mu\mu} + (F_{\text{H}})_{\nu\mu}^* \left(\frac{1}{2}\psi_{\nu\nu} + \Sigma_{l,\nu}\right) P_{\nu\nu} \\ &\quad + (\tilde{F}^\dagger Q P \tilde{F})_{\mu\nu} e^{(i/2)(\Psi_{\nu\nu} - \Psi_{\mu\mu})} + \text{h.p.}, \end{aligned} \quad (2.31)$$

where  $\tilde{F}_{\mu\nu}$  is the partial wave projection of

$$(q_\mu q_\nu)^{-l} |D_{\mu\nu}|^{-1} \bar{f}_{\mu\nu} (2E/\lambda)^{A_{\mu\nu}}. \quad (2.32)$$

Using (2.30) we find that the infrared divergent phases  $\psi$  cancel to first order, and (2.31) finally gives a  $\lambda$ -independent unitarity relation for  $F$ ;

$$\text{Im } F = F^\dagger Q \varphi^{-1} P F + \Sigma_l P F_H + F_H^\dagger P \Sigma_l + \mathcal{A}. \tag{2.33}$$

Here the matrices  $\varphi$  and  $\Sigma_l$  are diagonal with diagonal elements  $|D_{\mu\mu}(t=0)|$  and  $\Sigma_{l,\mu}$  respectively.  $\mathcal{A}$  is the absorption matrix

$$\mathcal{A} = \mathcal{E}^\dagger Q P F_H + F_H^\dagger Q P \mathcal{E} - \text{Im } \mathcal{E} + q^{-1} (S^\dagger P_h S)_l q^{-1}, \tag{2.34}$$

where  $\mathcal{E}$  is the partial wave projection of the matrix with entries

$$\lim_{\lambda \rightarrow 0} (q_\mu q_\nu)^{-1} (f_H)_{\mu\nu} \left[ \frac{\varphi_{\mu\mu}^{1/2} \varphi_{\nu\nu}^{1/2}}{|D_{\mu\nu}(s, t)|} \left( \frac{2E}{\lambda} \right)^{A_{\mu\nu}} - 1 \right], \tag{2.35}$$

$f_H$  being the pure hadronic scattering amplitude. In (2.35), the infrared divergence due to soft photon emission is cancelled by the factor  $|D_{\mu\nu}|$ . The  $\mathcal{E}$  terms in (2.34) describe the remaining absorptive effect of soft photon emission.

From (2.33) we derive in the usual way an explicit expression for  $\text{Im } F^{-1}$ . Together with (2.17) and (2.20) this gives

$$\begin{aligned} \text{Im } \mathcal{H} = \mathcal{N}^T (Q \varphi^{-1} - Q_H) P \mathcal{N} + \mathcal{D}^\dagger \Sigma_l P \mathcal{N} \\ + \mathcal{N}^T \Sigma_l P \mathcal{D} + \mathcal{D}^\dagger \mathcal{A} \mathcal{D}, \end{aligned} \tag{2.36}$$

from which one evaluates the physical cut integral in (2.22).

From (2.13) and (2.33) it follows that the open channel part of  $S_N$  is given by the simple relation

$$S_N^\dagger S_N + 4Q^{1/2} \mathcal{A} Q^{1/2} = I. \tag{2.37}$$

This is the analogue of equation (3.29) in Ref. [4].

### 2.5. The effective range equation

From the expression for  $\text{Im } F^{-1}$  one can form the  $K$ -matrix

$$K^{-1} = F^{-1} - \frac{s}{\pi} \int_{s_0}^\infty \frac{\text{Im } F^{-1}(s'+i)}{s'(s'-s)} ds', \tag{2.38}$$

which has no right-hand cut to order  $\alpha$ . Near the thresholds higher order terms are important. One can improve the threshold behaviour of  $K$  by replacing  $F$  by  $\hat{\varphi} F \hat{\varphi}$ , where

$$\hat{\varphi} = \prod_{n=1}^l \left( 1 + \frac{i\hat{\gamma}}{n} \right)^{-1}. \tag{2.39}$$

The matrix  $\hat{\gamma}$  is diagonal,  $\hat{\gamma}_{\mu\mu}$  being the Coulomb parameter of the  $\mu$ -channel. For this one may use the non-relativistic form (2.10), the relativistic form (A.4), or  $iL$ , where  $L$  is the function in equation (A.3) of Appendix A.

If the Coulomb interactions are attractive one must add the term

$$2\pi i Q \hat{\gamma} \coth(\pi \hat{\gamma}) \prod_{n=1}^l \left( 1 + \left( \frac{\hat{\gamma}}{n} \right)^2 \right) \tag{2.40}$$



on the right of (2.38) in order to compensate the poles coming from the Coulomb bound state zeros in  $F$  (see Refs. [1], [4] and [14] for details).

### 3. Application to $\pi N$ scattering

We shall now apply the general methods of Section 2 to  $\pi^+ p$  scattering and  $\pi^- p$  elastic and charge exchange scattering.

For  $\pi^+ p$  scattering there is only one  $\pi N$  channel and we write the  $\pi N$  part of  $S_N$  as

$$\eta e^{2i\delta}, \quad (3.1)$$

where  $\delta$  and  $\eta$  are the nuclear phase shift and inelasticity. The e.m. corrections to  $\delta$  and  $\eta$  are by definition

$$\Delta = \delta - \delta_H, \quad (3.2a)$$

$$\bar{\eta} = \eta_H - \eta, \quad (3.2b)$$

where  $\delta_H$  and  $\eta_H$  are the pure hadronic phase shift and inelasticity.

For  $\pi^- p$  scattering there are two  $\pi N$  channels,  $\pi^- p$  and  $\pi^0 n$ . The charge basis  $\{|\pi^- p\rangle, |\pi^0 n\rangle\}$  is transformed into the isospin basis  $\{|I = \frac{1}{2}\rangle, |I = \frac{3}{2}\rangle\}$  by the matrix

$$\frac{1}{\sqrt{3}} \begin{pmatrix} -\sqrt{2} & 1 \\ 1 & \sqrt{2} \end{pmatrix}. \quad (3.3)$$

In the isospin basis the  $\pi N$  part of  $S_N$  is written as

$$\begin{pmatrix} \eta^1 e^{2i\delta^1} & i\varepsilon e^{i(\delta^1 + \delta^3)} \\ i\varepsilon e^{i(\delta^1 + \delta^3)} & \eta^3 e^{2i\delta^3} \end{pmatrix}, \quad (3.4)$$

with

$$i\varepsilon = \frac{2}{3}\sqrt{2} (\eta_{13} + i\Delta_{13}), \quad (3.5)$$

where  $\delta^i, \eta^i$  ( $i = 1, 3$ ) are the (real) isospin  $i/2$  nuclear phase shift and inelasticity, and  $\eta_{13}$  and  $\Delta_{13}$  are (real) mixing parameters.

The  $\pi N$  part of the pure hadronic  $S$ -matrix  $S_H$  is assumed to be diagonal in the isospin basis and is written as

$$\begin{pmatrix} \eta_H^1 e^{2i\delta_H^1} & 0 \\ 0 & \eta_H^3 e^{2i\delta_H^3} \end{pmatrix}, \quad (3.6)$$

where the  $I = \frac{3}{2}$  component is the same as for  $\pi^+ p$  scattering, as required by our assumption of SU(2).

We define the phase shift corrections  $\Delta_1, \Delta_3$  by

$$\delta^1 = \delta_H^1 - \frac{2}{3}\Delta_1, \quad (3.7a)$$

$$\delta^3 = \delta_H^3 - \frac{1}{3}\Delta_3, \quad (3.7b)$$

and the inelasticity corrections  $\bar{\eta}_1, \bar{\eta}_3$  by

$$\bar{\eta}_i = \eta_H^i - \eta^i, \quad (i = 1, 3). \quad (3.8)$$

The mixing parameters  $\eta_{13}, \Delta_{13}$  are also to be considered as e.m. corrections.

In Ref. [11] we give the detailed expressions for the differential and total cross sections and the polarization in terms of the parameters in (3.1) and (3.4).

### 3.1. Inelasticity corrections

In the energy region where the  $\pi N$  channels are the only open hadronic channels it follows from (2.37) and (3.4) that to first order in  $\alpha$

$$\begin{pmatrix} 1 - (\eta^1)^2 & -\frac{4}{3}\sqrt{2} \eta_{13} e^{i(\delta^3 - \delta^1)} \\ -\frac{4}{3}\sqrt{2} \eta_{13} e^{-i(\delta^3 - \delta^1)} & 1 - (\eta^3)^2 \end{pmatrix} = 4Q^{1/2} \mathcal{A} Q^{1/2}, \quad (3.9)$$

from which  $\bar{\eta}_1$ ,  $\bar{\eta}_3$ , and  $\eta_{13}$  can be determined. For  $\pi^+ p$  scattering the same equation holds with only  $1 - \eta^2$  on the left.

For  $\pi^- p$  scattering the main term in the absorption matrix  $\mathcal{A}$  comes from the  $n\gamma$ -channel. A derivation based on (2.34) and (3.9) gives for total angular momentum  $J = l \pm \frac{1}{2}$ :

$$(\eta_{\text{H}}^i + \eta_{\text{H}}^j) \eta_{ij} = 3\sqrt{2} q_\gamma q \{ l(l+1) |M_{l\pm}^{i/2} M_{l\pm}^{j/2}| + (l \pm 1)(l + 1 \pm 1) |E_{l\pm}^{i/2} E_{l\pm}^{j/2}| \} \quad (i, j = 1, 3), \quad (3.10)$$

where  $\bar{\eta}_1$  and  $\bar{\eta}_3$  are given by  $\bar{\eta}_i = \frac{2}{3}\sqrt{2} \eta_{ii}$ , and  $q_\gamma$ ,  $q$  are the c.m. momenta of the  $n\gamma$  and  $\pi N$  systems. The electric multipole amplitudes are

$$E_{l\pm}^{1/2} = \frac{1}{\sqrt{3}} (E_{l\pm}^{(1)} - 3E_{l\pm}^{(0)}), \quad E_{l\pm}^{3/2} = \sqrt{\frac{2}{3}} E_{l\pm}^{(3)}, \quad (3.11)$$

and similarly for the magnetic ones [15]. Equation (3.10) holds approximately also for  $\eta_{\text{H}}^i < 1$ , i.e., above the inelastic threshold. Table 1 gives the  $n\gamma$  inelasticity corrections calculated from the multipole amplitudes of Moorhouse et al. [16].

In addition there is the absorption due to bremsstrahlung. The present experimental results [17] on  $\pi N$  bremsstrahlung (obtained at pion lab kinetic energies  $T_L = 260, 294, \text{ and } 298 \text{ MeV}$ ) agree very well with the soft photon approximation for photon energies up to about  $\frac{2}{3}$  of the maximum photon c.m. energy  $E_{\text{max}}$ . We therefore

Table 1  
The  $n\gamma$ -channel contribution to the  $\pi^- p$  inelasticity corrections

$q/\mu$	$S_{1/2}$			$P_{1/2}$			$P_{3/2}$		
	$\bar{\eta}_1$	$\bar{\eta}_3$	$\eta_{13}$	$\bar{\eta}_1$	$\bar{\eta}_3$	$\eta_{13}$	$\bar{\eta}_1$	$\bar{\eta}_3$	$\eta_{13}$
0.8	17 <sup>1)</sup>	6	11	0.2	0.4	0.3	0.7	4	2
1.2	26	9	16	1	2	1	3	49	10
1.4	28	10	18	1	2	2	4	89	16
1.6	30	10	19	2	2	2	5	113	20
1.8	31	11	20	2	3	3	6	91	20
2.0	32	12	21	3	3	3	7	61	18
2.5	31	14	22	4	3	3	9	20	13

<sup>1)</sup> All numbers are to be multiplied by  $10^{-4}$ .

estimate the bremsstrahlung contribution to  $\bar{\eta}_1$ ,  $\bar{\eta}_3$ , and  $\eta_{13}$  by just using the  $\mathcal{E}$ -terms in the absorption matrix with the cut off energy  $E = \frac{2}{3}E_{\max}$ , ignoring the contributions from photons of higher energy. The results of such a calculation for the  $S$ - and  $P$ -waves are shown in Table 2. The corrections are seen to be negligible in all cases.

Table 2  
Bremsstrahlung contribution to the  $\pi^- p$  inelasticity corrections

$q/\mu$	$S_{1/2}$			$P_{1/2}$			$P_{3/2}$		
	$\bar{\eta}_1$	$\bar{\eta}_3$	$\eta_{13}$	$\bar{\eta}_1$	$\bar{\eta}_3$	$\eta_{13}$	$\bar{\eta}_1$	$\bar{\eta}_3$	$\eta_{13}$
0.8	-0.2 <sup>1)</sup>	-0.2	0.1	-0.1	0	-0.1	-0.1	-0.1	0
1.2	-0.7	-0.7	-0.2	-0.1	-0.1	-0.1	-0.5	-1.6	0.1
1.4	-1.4	-1.1	-0.8	0	0	0	-1.3	-3.6	0.2
1.6	-1.4	-0.9	-0.8	0.1	0	0.1	-2.0	-3.2	0.1
1.8	-0.5	-0.3	-0.2	0.3	0.1	0.2	-1.6	-0.1	-0.1
2.0	0.6	0.1	-0.1	0.5	0.1	0.1	-1.0	2.2	-0.5
2.5	3.7	2.5	-0.8	8.9	0	-2.5	1.1	4.7	-2.4

<sup>1)</sup> All numbers are to be multiplied by  $10^{-4}$ .

For  $\pi^+ p$  scattering the absorption is due only to bremsstrahlung, and here a similar calculation leads to the same conclusion (cf. Table 1 in Ref. [4]).

### 3.2. Phase shift corrections

To derive  $\delta F$  from (2.23) one needs a fairly complete  $N/D$  model for the full hadronic partial wave amplitude  $F_H$  (including the inelastic channels) even if one is interested only in the  $\pi N$  scattering part of  $\delta F$ . There exists, however, a slightly different method which involves only the known  $\pi N$  amplitude [4]. Instead of using (2.21) we may define a function  $\mathcal{H}_R$  by

$$\mathcal{H}_R = \Lambda^{-1/2}(F^R - F_H^R)\Lambda^{-1/2}, \quad (3.12)$$

where  $F^R$ ,  $F_H^R$  are now only the reduced part (i.e., the  $\pi N$  part) of  $F$ ,  $F_H$ .

For  $\pi^- p$  scattering,  $\Lambda$  is in the isospin basis given by

$$\Lambda = \begin{pmatrix} \Lambda_1 & 0 \\ 0 & \Lambda_3 \end{pmatrix}, \quad (3.13)$$

with

$$\Lambda_i = \exp \left[ \frac{2s}{\pi} \int_{s_0}^{\infty} \frac{\delta_H^i}{s'(s' - s)} ds' \right], \quad (i = 1, 3), \quad (3.14)$$

where  $s_0 = (M + \mu)^2$ ,  $M$  and  $\mu$  being the proton and charged pion masses. On the physical cut,

$$\Lambda_j = |\Lambda_j| \exp(2i \delta_H^j), \quad (j = 1, 3). \quad (3.15)$$

For  $\pi^+ p$  scattering we use  $\Lambda = \Lambda_3$ .

The two functions  $\mathcal{H}$  and  $\mathcal{H}_R$  would coincide if there were no inelastic hadronic channels. Also,  $\mathcal{H}_R$  has the same analytic structure as  $F_R$ . In analogy with (2.23) we have to order  $\alpha$

$$\Lambda^{1/2} \mathcal{H}_R \Lambda^{1/2} = (\mathcal{C} - \frac{1}{2} Q^{-1} \delta Q) F_H + F_H (\mathcal{C} - \frac{1}{2} Q^{-1} \delta Q) + \frac{S_N - S_H}{2iq^{2l+1}}. \quad (3.16)$$

The quantities on the right are here the reduced part of the corresponding quantities in Section 2.

In order to specify  $\delta Q = Q - Q_H$  we now choose to use the proton and charged pion masses  $M$  and  $\mu$  for the pure hadronic masses. Thus  $\delta Q = 0$  for  $\pi^+ p$  scattering, while for  $\pi^- p$

$$\delta Q = (q_0^{2l+1} - q_-^{2l+1}) P_0, \quad (3.17)$$

where  $P_0$  is the projection on the  $\pi^0 n$  state, and  $q_-, q_0$  are the momenta of the  $\pi^- p$  and  $\pi^0 n$  systems. Clearly  $q_H = q_-$ .

It follows from equations (3.15), (3.4), and (3.6) that on the physical cut the expression  $(1/2i)\Lambda^{-1/2}(S_N - S_H)\Lambda^{-1/2}$  is identical to

$$\begin{pmatrix} \frac{-\frac{2}{3}\eta_H^1 \Delta_1 + (i/2)\bar{\eta}_1}{|\Lambda_1|} & \frac{\sqrt{2} \Delta_{13} - i\eta_{13}}{3 |\Lambda_1 \Lambda_3|^{1/2}} \\ \frac{\sqrt{2} \Delta_{13} - i\eta_{13}}{3 |\Lambda_1 \Lambda_3|^{1/2}} & \frac{-\frac{1}{3}\eta_H^3 \Delta_3 + (i/2)\bar{\eta}_3}{|\Lambda_3|} \end{pmatrix} \quad (3.18a)$$

for  $\pi^- p$  scattering. For  $\pi^+ p$  it is simply

$$\frac{(\eta_H \Delta + (i/2)\bar{\eta})}{|\Lambda_3|}. \quad (3.18b)$$

Combining this with (3.16) one sees that the corrections  $\Delta$  are connected with  $\text{Re } \mathcal{H}_R$ , while  $\text{Im } \mathcal{H}_R$  is independent of  $\Delta$ . Thus the corrections may be found by the use of a dispersion relation for  $\mathcal{H}_R$  (cf. Appendix B for detailed expressions).

This method was used in Ref. [4] to determine the phase shift corrections to the  $\pi^+ p$   $S$ - and  $P$ -waves and we have also used it to determine the  $S$ -wave corrections and  $\Delta_3(P_{1/2})$  for  $\pi^- p$  scattering. Our results for the latter are given in Table 3.

The method leads to the most reliable results in the cases where  $\delta_H^i$  goes to a negative value at high energies. This follows from the asymptotic behaviour of  $|\Lambda_i|$  which is [18]

$$|\Lambda_i| \rightarrow \text{const.} \times |s|^{-2\delta_H^i(\infty)/\pi} \quad (3.19)$$

as  $|s| \rightarrow \infty$ . In the dispersion relation for  $\mathcal{H}_R$  the behaviour (3.19) gives rise to an enhancement (suppression) of the high energy contributions when  $\delta_H^i(\infty)$  is positive (negative). This is most serious for the left-hand cut, where we are able to calculate only the long range part of the dispersion integral. Ignoring the short range contributions may be dangerous in cases where these are enhanced by the  $\Lambda$  function.

The problem with the asymptotic behaviour (3.19) arises only if we insist on using a single channel method. If a phase shift is large and positive at higher energies, this is generally due to strongly attractive forces in one or more of the related inelastic channels. This is most easily taken into account by using the multichannel  $N/D$

Table 3  
Phase shift corrections (in degrees) to  $\pi^- p$  scattering

$q/\mu$	$S_{1/2}$			$P_{1/2}$	$P_{3/2}$		
	$\Delta_1$	$\Delta_3$	$\Delta_{13}$	$\Delta_3$	$\Delta_1$	$\Delta_3$	$\Delta_{13}$
0.5	-0.31	0.52	0.06	0.11	0.02	-0.74	0.11
0.8	-0.21	0.35	0.06	0.21	0.05	-1.48	0.15
1.0	-0.15	0.30	0.07	0.28	0.08	-2.13	0.15
1.2	-0.10	0.27	0.08	0.34	0.11	-2.87	0.12
1.3	-0.07	0.26	0.09	0.37	0.13	-3.09	0.09
1.4	-0.05	0.25	0.10	0.39	0.14	-2.82	0.05
1.5	-0.02	0.24	0.11	0.41	0.16	-1.93	-0.02
1.6	0	0.24	0.12	0.43	0.17	-0.73	-0.08
1.8	0.03	0.22	0.15	0.47	0.20	0.87	-0.16
2.0	0.05	0.21	0.17	0.52	0.23	1.23	-0.18
2.5	0.14	0.18	0.24	0.63	0.36	0.83	-0.16

method outlined in Section 2. This method should be safer to use than the one discussed above, e.g. for the  $P_{11}$  and  $P_{33}$  waves both of which have large and positive phase shifts at high energies.

For  $P_{11}$  we have at present no  $N/D$  model that gives a satisfactory fit to the observed phase shift and inelasticity. Therefore the  $N/D$  method cannot be used to get reliable estimates for  $\Delta_1(P_{1/2})$  and  $\Delta_{13}(P_{1/2})$ . However, a calculation using the single channel equation (B.5) gives very small values for these corrections, at least in the region of the  $P_{33}$  resonance, so we believe they can simply be ignored (see also the results in Ref. [8]).

For the  $P_{33}$  partial wave Ball et al. [19] have constructed a two-channel  $N/D$  model that reproduces both the phase shift and inelasticity with good accuracy. In this model the first channel is the  $\pi N$  state and the second is a  $P$ -wave state of masses  $M$  and  $4\mu$ . The latter should be considered as an effective channel, simulating the combined effects of the  $\pi\Delta$ ,  $\rho N$ ,  $K\Sigma$ , and maybe other channels. It is therefore not clear what charges one should use for the second channel. We take the simplest possibility and assume the particles to be neutral.

Using this two-channel  $N/D$  model in (2.22) and (2.23) we have recalculated the correction to the  $P_{33}$  phase shift in  $\pi^+ p$  scattering. The result is given in Table 4 together with the  $\pi^+ p$  corrections obtained from the single channel method (cf. Ref. [4]). The two methods are seen to give very similar results for the  $P_{33}$  correction. At low energies ( $q \lesssim \mu$ ) the dominant terms are identical in the two cases. At higher energies, however, corresponding terms come out very different with the two methods, but they add up to give total corrections that are surprisingly close. This result seems to indicate that the total correction is to some extent insensitive to what  $N/D$  model is used, as long as it reproduces the measured  $\pi N$  partial wave.

For the  $P_{3/2}$  partial wave in  $\pi^- p$  scattering we use a 'mixture' of the two methods. Our  $\mathcal{D}$ -matrix is here of the form

$$\begin{pmatrix} \Lambda_1 & 0 \\ 0 & D_3 \end{pmatrix}$$



Table 4

The correction to the  $\pi^+ p$   $P_{33}$  phase shift, obtained from equations (2.22) and (2.23) using the two-channel  $N/D$  model of Ball et al. (column 6). For comparison and completeness we have included (in columns 3–5) the  $\pi^+ p$  corrections obtained [4] from equations (B.5) and (B.8) in Appendix B.

$q/\mu$	$T_L$ [MeV]	$\Delta(S_{1/2})$	$\Delta(P_{1/2})$	$\Delta(P_{3/2})$	$N/D$ $\Delta(P_{3/2})$
0.5	22.1 <sup>1)</sup>	0.10	0.01	-0.07	-0.07
0.8	53.7	0.09	0.02	-0.23	-0.23
1.0	80.7	0.10	0.04	-0.47	-0.47
1.2	111.8	0.10	0.05	-0.90	-0.90
1.3	128.7	0.11	0.06	-1.18	-1.19
1.4	146.4	0.11	0.07	-1.39	-1.42
1.5	164.9	0.12	0.08	-1.36	-1.42
1.6	184.3	0.12	0.09	-1.10	-1.13
1.8	225.2	0.13	0.10	-0.31	-0.36
2.0	269.1	0.13	0.12	0.13	0.07
2.5	391.1	0.14	0.15	0.44	0.32

<sup>1)</sup>  $T_L$  is the pion lab kinetic energy

where  $D_3$  is the two-channel  $\mathcal{D}$ -matrix of Ball et al. [19]. Our results for the corrections are given in Table 3.

We shall now discuss the various contributions to the corrections.

*Nucleon exchange.* The only left-hand cut term we include in the dispersion relation for  $\mathcal{H}$  (or  $\mathcal{H}_R$ ) is the one that arises from nucleon exchange in the  $u$ -channel of the  $\pi N$  system. The integral is over the cut singularity  $(M - \mu)^2 \leq s \leq M^2 + 2\mu^2$  of  $\mathcal{H}(s)$  in the  $s$ -plane and the discontinuity of  $\mathcal{H}(s)$  across the cut is derived from the  $u$ -channel absorptive parts of the graphs (a)–(d) in Figure 1. The absorptive part of (d) is obtained from the photoproduction amplitudes, and for these we use the Born approximation [4, 20].

To obtain the absorptive parts of the graphs (a)–(c) we have to know the  $\pi NN$  coupling constants  $\bar{G}_{\pi^- pn}$ ,  $\bar{G}_{\pi^0 pp}$  and  $\bar{G}_{\pi^0 nn}$ . These coupling constants are finite and  $\lambda$ -independent and are defined by

$$\bar{G} = \lim_{\lambda \rightarrow 0} D_{\pi N, N} G, \quad (3.20)$$

where  $G$  is the value of the relevant  $\pi NN$  vertex function when all three external particles are on the mass shell. Clearly  $\bar{G}_{\pi^0 nn} = G_{\pi^0 nn}$ . The definition (3.20) is analogous to our definition of the finite  $S$ -matrix  $\bar{S}_{CH}$  (cf. equation (2.3)).

We take the nucleon exchange graph that contributes to  $F_H$  to be the same as that for  $\pi^+ p$  scattering (Fig. 1a) except that  $G_{\pi^- pn}$  is replaced by  $\bar{G}_{\pi^- pn}$ . This means that for  $\pi^- p$  scattering where nucleon exchange appears in the reactions  $\pi^- p \rightarrow \pi^0 n$  and  $\pi^0 n \rightarrow \pi^0 n$  (cf. Fig. 1b, 1c) there will be contributions to  $\Delta_1$ ,  $\Delta_3$ , and  $\Delta_{13}$  proportional to respectively

$$3\bar{G}_{\pi^- pn}^2 + \bar{G}_{\pi^0 nn}^2 - 4\bar{G}_{\pi^0 pp} \bar{G}_{\pi^- pn}, \quad (3.21a)$$

$$\frac{3}{2}\bar{G}_{\pi^- pn}^2 - \frac{1}{2}\bar{G}_{\pi^0 nn}^2 - \bar{G}_{\pi^0 pp} \bar{G}_{\pi^- pn}, \quad (3.21b)$$

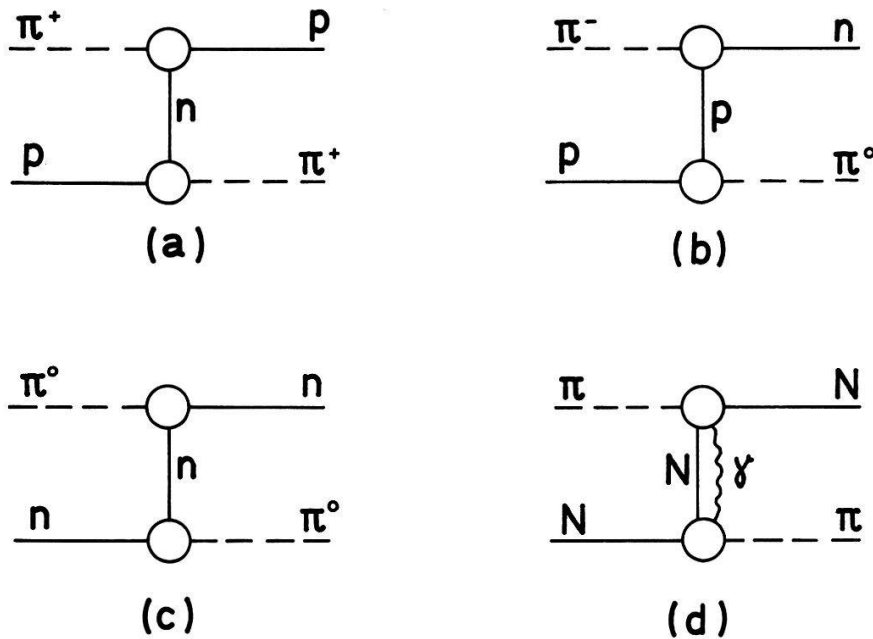

Figure 1  
The nucleon exchange graphs which contribute to the dispersion integral for  $\mathcal{H}$  or  $\mathcal{H}_R$ .

and

$$2\bar{G}_{\pi^0 pp} \bar{G}_{\pi^- pn} - 2\bar{G}_{\pi^0 nn}^2 \quad (3.21c)$$

from the short nucleon exchange cut  $(M - \mu^2/M)^2 \leq s \leq M^2 + 2\mu^2$ . Unfortunately very little [21] is known about the differences between  $\bar{G}_{\pi^- pn}$ ,  $\bar{G}_{\pi^0 pp}$ , and  $\bar{G}_{\pi^0 nn}$ . We are therefore not able to calculate these contributions. However, to get an idea about the possible size we have calculated the contributions for the  $P_{3/2}$  waves taking arbitrarily the factors (3.21) to be  $0.02\bar{G}^2$ , with  $\bar{G}^2/4\pi \simeq 14$ . (For  $\bar{G}_{\pi^0 nn} = \bar{G}_{\pi^0 pp}$  the factors (3.21) are all approximately equal to  $\bar{G}_{\pi^- pn}^2 - \bar{G}_{\pi^0 nn}^2$ .) The results are the dotted curves 'g' in Figures 2–4. (These numbers are, of course, not included in our total corrections, given in Table 3.) We note that with the present  $N/D$  model the left-hand cut contribution to  $\Delta_3$  is strongly suppressed compared to the corresponding contribution in the single channel method (cf. Fig. 12 in Ref. [2]).

*Corrections due to mass differences.* In  $\pi^- p$  scattering there is also a contribution due to the mass differences of the external particles and of the intermediate nucleons in the various nucleon exchange graphs (cf. Fig. 1a–1c). It was stated in Ref. [3] that the pion mass difference has no influence on this contribution. This is correct at very high energies but in the resonance region the main effect is due to the pion mass difference.

The most important mass difference effect comes, however, from the physical cut terms involving  $\delta Q$  in (2.23) or (3.16).

Our result for the sum of these two effects is shown for the  $P_{3/2}$  case as curve 'm.d.' in Figures 2–4. Notice that the mass difference contribution dominates the structure of the total  $P_{33}$  correction.

*The  $n\gamma$  contribution.* The  $n\gamma$ -channel in  $\pi^- p$  scattering gives rise to a radiative  $M^2 \leq s \leq \infty$  in  $\mathcal{H}(s)$  and  $\mathcal{H}_R(s)$ . The corresponding absorptive part of  $\mathcal{H}_R$  comes

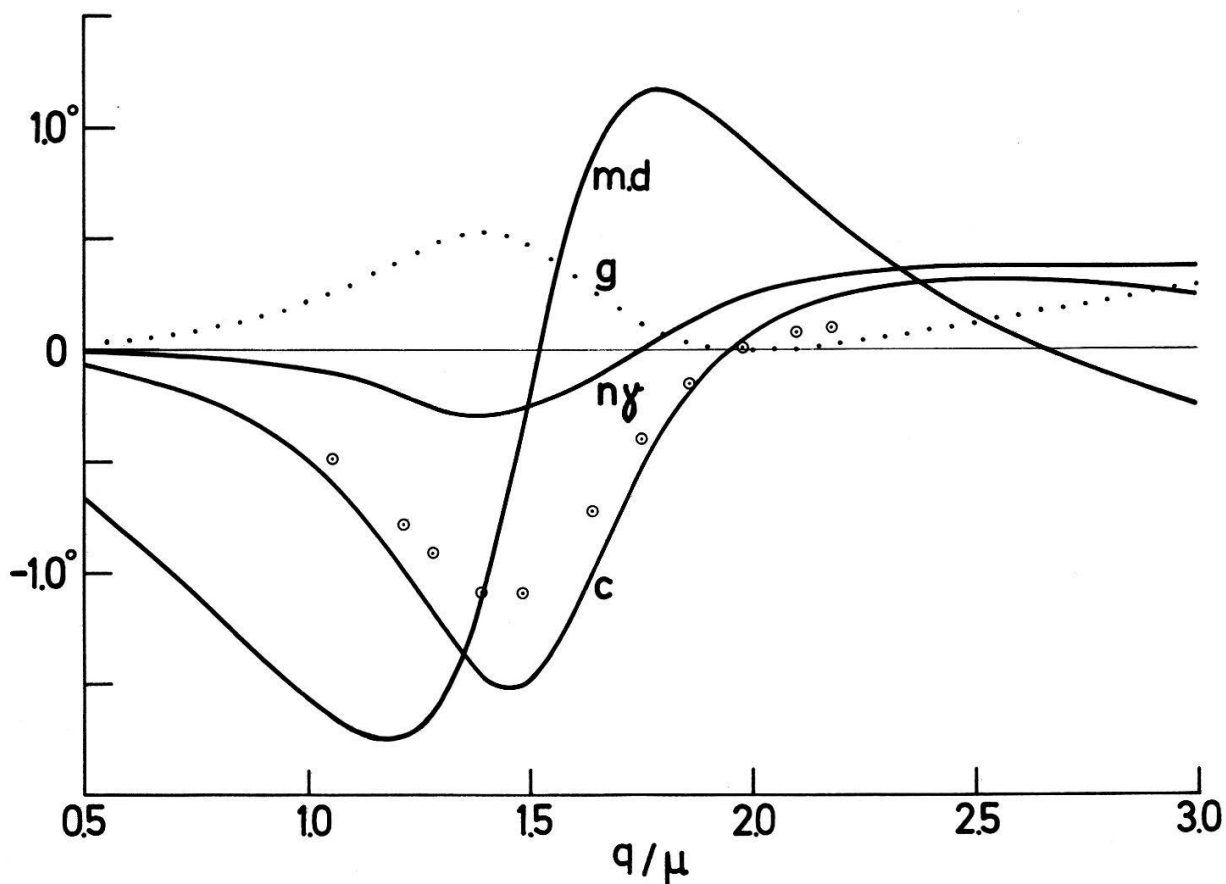

Figure 2

The contributions to  $\Delta_3(P_{3/2})$  in  $\pi^-p$  scattering. They are (c) the Coulomb correction, (m.d.) the mass difference contribution, and ( $n\gamma$ ) the contribution from the  $n\gamma$ -channel. The circles show the results by Bugg [8]. The dotted curve (g) illustrates the effect of coupling constant differences.

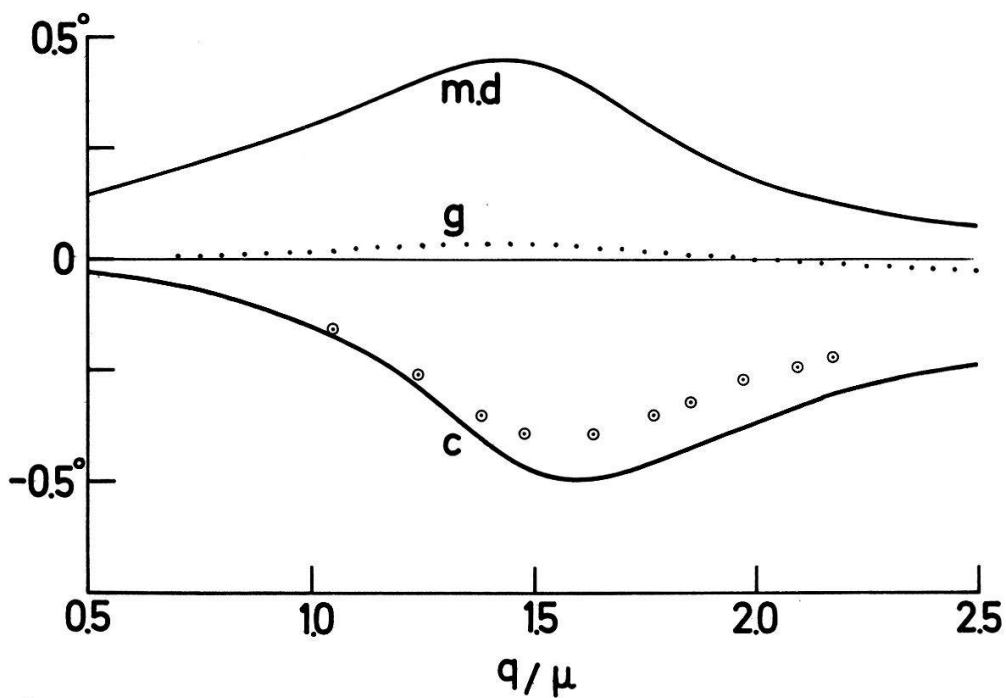

Figure 3

The contributions to  $\Delta_{13}(P_{3/2})$ . Same notation as in Figure 2. The  $n\gamma$  contribution is negligible and is not shown.

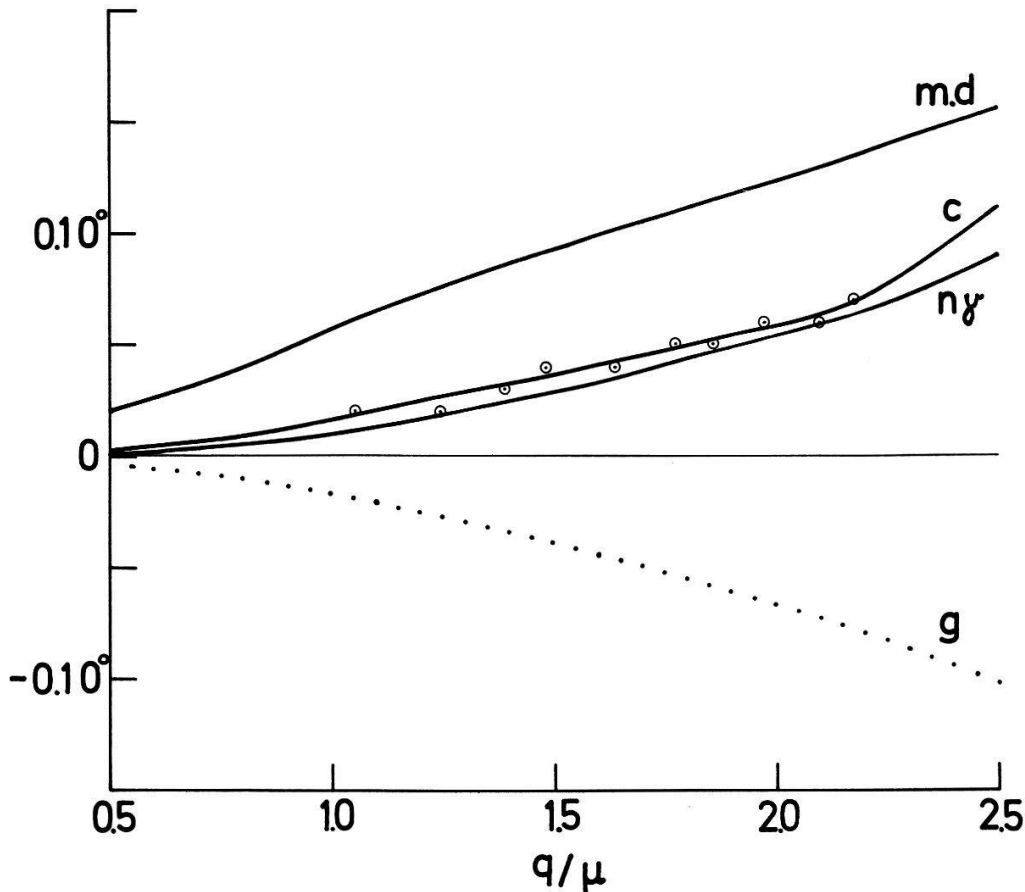

Figure 4  
The contributions to  $\Delta_1(P_{3/2})$ . Same notation as in Figure 2.

from the  $\eta_{ij}$  term in equation (B.8). On the physical cut we use the values of  $\eta_{ij}$  given in Table 1. In the unphysical region we derive  $\text{Im } \mathcal{H}_R$  from the extrapolated photoproduction amplitudes. The Born terms in the photoproduction amplitudes give rise to an endpoint singularity in  $\mathcal{H}_R$  at  $s = M^2$ . We refer to Refs. [2] and [20] for a discussion of how to deal with this singularity in a dispersion relation.

The discontinuity of  $\mathcal{H}(s)$  due to the  $n\gamma$ -channel is derived from the absorption matrix term in (2.36). In the matrix  $\mathcal{A}$  we have ignored the terms involving the amplitude for the effective channel going to  $n\gamma$ . This is not consistent with analyticity and unitarity, but probably is a good approximation below the threshold of the effective channel.

The contribution from the  $n\gamma$ -channel to the  $P_{3/2}$  corrections are shown as curve 'n $\gamma$ ' in Figures 2–4.

*The Coulomb correction.* The contribution from the terms containing the matrix  $\mathcal{C}$  in (2.23) and (3.16) is called the Coulomb correction. In this we also include the left-hand cut contribution from graph (d) of Figure 1 and the term coming from the difference between  $G$  and  $\bar{G}$ . The corrections to  $\pi^+p$  are therefore entirely Coulomb corrections. Apart from the left-hand cut terms they are equal to the corresponding corrections  $\Delta_3$  to  $\pi^-p$  scattering.

The Coulomb corrections mostly arise from the Coulomb scattering of the external particles. It is therefore not surprising that our results for these agree qualitatively with the corrections obtained from potential theory (cf. Section IID in

Ref. [4] for a discussion of the relation between the potential theory and dispersion relation methods). Thus the circles in Figures 2–4, showing Bugg’s results [8] obtained from a relativistic potential model, are seen to be close to our Coulomb corrections (curve ‘c’).

*Short range contributions.* As already mentioned, we are not able to determine the short range part of the left-hand cut integrals in the dispersion relations for  $\mathcal{H}$  or  $\mathcal{H}_R$ . Furthermore, we have not taken into account the short range contribution due to e.m. effects in the inelastic channels. These effects would contribute to the high energy part of the physical cut integral.

Although the short range contribution to  $\text{Re } \mathcal{H}_R$  is unknown, it clearly is slowly varying in the resonance region. It therefore follows from equation (B.5) that the structure of the contribution is determined by the factor  $q^{2l+1} |\Lambda_i \Lambda_j|^{1/2}$ . For  $P_{33}$  this factor is to a good approximation proportional to  $\sin^2 \delta_H^3$ . The short range contributions to the  $P_{33}$  corrections therefore are of the form

$$h(s) \sin^2 \delta_H^3, \tag{3.22}$$

where  $h(s)$  varies slowly in the resonance region. The same conclusion follows from an argument based on the multi-channel method.

### 3.3. The branching ratio $\Gamma(\Delta^\circ \rightarrow \pi^- p) / \Gamma(\Delta^\circ \rightarrow \pi^0 n)$

If we for a moment ignore the  $n\gamma$ -channel we find that  $\exp(2i\delta^3)$  is an eigenvalue to the matrix (3.4) with corresponding eigenvector

$$\left(\frac{1}{3}\sqrt{2} \Delta_{13} / \sin(\delta^3 - \delta^1), 1\right). \tag{3.23}$$

Consider now the  $P_{3/2}$  wave. At the resonance position  $s_r$ , given by  $\delta^3(s_r) = \frac{1}{2}\pi$ , we identify the eigenstate (3.23) with the  $\Delta^\circ$  particle. Thus in the charge basis,

$$|\Delta^\circ\rangle = \frac{1}{\sqrt{3}} (1 - \sqrt{2} a) |\pi^- p\rangle + \frac{1}{\sqrt{3}} (a + \sqrt{2}) |\pi^0 n\rangle, \tag{3.24}$$

where

$$a = \frac{\sqrt{2}}{3} \frac{\Delta_{13}}{\cos \delta^1} \Big|_{s=s_r} \simeq -0.001. \tag{3.25}$$

This gives the branching ratio

$$\frac{\Gamma(\Delta^\circ \rightarrow \pi^- p)}{\Gamma(\Delta^\circ \rightarrow \pi^0 n)} = \left| \frac{1 - \sqrt{2} a}{\sqrt{2} + a} \right|^2 \simeq \frac{1}{2} \cdot 1.004. \tag{3.26}$$

If the  $n\gamma$ -channel is included, the eigenphase of the enlarged  $S$ -matrix becomes  $\delta^3 + \frac{1}{2}\bar{\eta}_3 \cot \delta^3$  and for  $s = s_r$ , the corresponding eigenvector is

$$(a, 1, \sqrt{6q_\gamma q} E_{1+}^{3/2}, \sqrt{2q_\gamma q} M_{1+}^{3/2}), \tag{3.27}$$

where the last two components are the electric and magnetic components of the  $n\gamma$ -channel. We notice that the introduction of the  $n\gamma$ -channel does not change the branching ratio (3.26) except through  $\Delta_{13}$ . However, the  $n\gamma$  contribution to  $\Delta_{13}$  is negligible.



If we for  $\Delta_{13}$  use only the first term on the right of equation (B.5), we find

$$\frac{\Gamma(\Delta^\circ \rightarrow \pi^- p)}{\Gamma(\Delta^\circ \rightarrow \pi^0 n)} \simeq \frac{1}{2} \left( \frac{q_-}{q_0} \right)^3 e^R \simeq \frac{1}{2} \cdot 0.998. \quad (3.28)$$

for  $s = s_r$ . This approximation is essentially the penetration model result [22], as can be seen by noting that

$$e^R \propto \frac{e^{2\pi\gamma} - 1}{2\pi\gamma} \quad (3.29)$$

in the non-relativistic limit (cf. equations (B.4), (A.11), and (2.10)).

### 3.4. Masses and widths of the $\Delta^{++}$ and $\Delta^\circ$ resonances

We define the mass  $M_{\Delta^{++}}$  ( $M_{\Delta^\circ}$ ) of the  $\Delta^{++}$  ( $\Delta^\circ$ ) resonance to be the value of  $W (= \sqrt{s})$  for which the nuclear  $P_{33}$  phase shift in  $\pi^+ p$  ( $\pi^- p$ ) scattering passes through  $\frac{1}{2}\pi$ . The widths  $\Gamma$  are determined from the nuclear phase shift by

$$\left. \frac{d\delta}{dW} \right|_{W=M_\Delta} = \frac{2}{\Gamma}. \quad (3.30)$$

The differences in masses and widths are therefore given by

$$M_{\Delta^{++}} - M_{\Delta^\circ} \simeq -\frac{1}{2}\Gamma(\Delta + \frac{1}{3}\Delta_3), \quad (3.31)$$

$$\Gamma_{\Delta^{++}} - \Gamma_{\Delta^\circ} \simeq -\frac{1}{2}\Gamma^2 \frac{d}{dW}(\Delta + \frac{1}{3}\Delta_3), \quad (3.32)$$

where the right-hand sides are evaluated at the resonance,  $\Delta$  and  $-\frac{1}{3}\Delta_3$  being the corrections to the  $P_{33}$  phase shifts in  $\pi^+ p$  and  $\pi^- p$  scattering (cf. equations (3.2a) and (3.7b)). (Like the definitions of mass and width themselves these definitions of the shifts are not very unique.)

From our results for  $\Delta$  and  $\Delta_3$  we find (in MeV/c<sup>2</sup>)<sup>2)</sup>

$$M_{\Delta^{++}} - M_{\Delta^\circ} \simeq 1.0, \quad (3.33)$$

$$\Gamma_{\Delta^{++}} - \Gamma_{\Delta^\circ} \simeq -5.2. \quad (3.34)$$

As discussed in Section 3.2 we have not included the short range contributions, which will give an additional term of the form (3.22) in the expression for  $\Delta + \frac{1}{3}\Delta_3$ . The corresponding contributions to the shifts in width and mass will have a ratio roughly equal to

$$\left. \frac{\Gamma}{h} \frac{dh}{dW} \right|_{W=M_\Delta}. \quad (3.35)$$

Since  $h$  is supposed to be slowly varying it follows that the short range contribution should mainly influence the mass shift.

<sup>2)</sup> In the same way as for the branching ratio we reproduce essentially the penetration model result by using only the first term on the right of eq. (B.5). This gives no mass difference and

$$\Gamma_{\Delta^{++}} - \Gamma_{\Delta^\circ} \simeq -\frac{4}{3}\Gamma[R + 1 - (q_-/q_0)^{3/2}] \simeq -2.5.$$

The shifts (3.31) and (3.32) are also influenced by the differences between the various  $\pi NN$  coupling constants. The arbitrary choice of  $0.02 \bar{G}^2$  for the combination (3.21b) (cf. curve 'g' in Figure 2) gives shifts of only  $-0.08$  and  $0.15 \text{ MeV}/c^2$  in the mass and width. This shows that in the present  $N/D$  model calculation the coupling constant differences have to be large in order to cause serious errors.

A comparison between (3.33)–(3.34) and experiments must wait until a new phase shift analysis has been carried out. The nuclear phase shifts obtained in the analysis of Carter et al. were reported to give [8] (see also Ref. [23])

$$M_{\Delta^{++}} - M_{\Delta^0} = -1.4 \pm 0.4, \quad (3.36)$$

$$\Gamma_{\Delta^{++}} - \Gamma_{\Delta^0} = -10.3 \pm 1.3. \quad (3.37)$$

However, this result cannot be compared directly with (3.33)–(3.34) because the analysis was not carried out in a way consistent with our corrections. A scheme for a practical data analysis consistent with our corrections is presented in Ref. [11].

Although the results of such an analysis may turn out to differ from the values of Carter et al., it may be of interest to study how short range e.m. effects *could* produce results like (3.36) and (3.37). By (3.35), this would require

$$\frac{\Gamma}{h} \frac{dh}{dW} \simeq 2,$$

i.e.,  $|h|$  would have to increase in the resonance region. Also, the contributions would have to be of the same size as those already encountered. We expect the left-hand contribution to  $h(W)$  due to e.m. modification of the driving forces in  $\pi N \rightarrow \pi N$  to be numerically decreasing with energy, unless cancellation effects are active. If results like (3.36) and (3.37) persist in future analyses, it therefore seems that one will have to look for further e.m. effects in the *inelastic* channels.

## Acknowledgements

We are grateful to Professor J. Hamilton for many helpful discussions. We would also like to thank NORDITA and the University of Trondheim (NLHT) for hospitality and financial support. During the completion of this work one of us (I.Ø.) has been supported by the Norwegian Research Council for Science and the Humanities.

## Appendix A

The function  $D_{\mu\nu}$  that we use in equation (2.3) to give an infrared convergent  $S$ -matrix is defined [24] as the product

$$D_{\mu\nu} = \prod_{i < j} (D_{\mu\nu})_{ij} \quad (A.1)$$

over all pairs of the four external particles  $A_\mu, B_\mu, A_\nu, B_\nu$ . The same definition also applies to the function  $D$  used in (3.20); in this case  $i, j$  run over all pairs of the three particles of the vertex.

Let  $q_{ij}$  and  $s_{ij}$  be the c.m. momentum and energy squared in the channel where

the particles  $i$  and  $j$  are both incoming or both outgoing. We shall refer to this as the  $ij$ -channel.

To define  $(D_{\mu\nu})_{ij}$  we need the two functions  $(Y_{\mu\nu})_{ij}$  and  $(L_{\mu\nu})_{ij}$  which we write as  $Y$  and  $L$  for short. These functions depend only on  $s_{ij}$  and are real analytic in the  $s_{ij}$ -plane cut along  $(s_0)_{ij} \leq s_{ij} \leq \infty$ , where  $(s_0)_{ij} = (m_i + m_j)^2$ ,  $m_i$  and  $m_j$  being the masses of  $i$  and  $j$ .

On the cut

$$\text{Im } Y(s_{ij}+) = \frac{1}{2}\gamma_{ij} \int_{-4q_{ij}^2}^0 \frac{F_i(x)F_j(x)}{x - \lambda^2} dx, \quad (\text{A.2})$$

and

$$\text{Im } L(s_{ij}+) = -\gamma_{ij}, \quad (\text{A.3})$$

where  $\gamma_{ij}$  is the Coulomb parameter

$$\gamma_{ij} = Z_i Z_j \alpha \frac{s_{ij} - m_i^2 - m_j^2}{2q_{ij}(s_{ij})^{1/2}} = Z_i Z_j \frac{\alpha}{v_{ij}}, \quad (\text{A.4})$$

$Z_i, Z_j$  being the charges in the  $ij$ -channel and  $v_{ij}$  being the relativistic lab relative velocity. The  $F_i, F_j$  are the charge form factors.

Equation (A.2) shows that  $\text{Im } Y$  is equal to the  $S$ -wave phase shift derived from the singular part of the one-photon exchange amplitude in the  $ij$ -channel

$$f_{C\lambda}^B = \frac{2q_{ij}\gamma_{ij}}{t_{ij}} F_i(t_{ij})F_j(t_{ij}) + \text{non-singular terms}, \quad (\text{A.5})$$

$t_{ij}$  being the momentum transfer in the  $ij$ -channel.

For point charges ( $F_i = F_j \equiv 1$ )

$$\text{Im } Y = -\gamma_{ij} \ln(2q_{ij}/\lambda), \quad (s_0)_{ij} \leq s_{ij} \leq \infty, \quad (\text{A.6})$$

which is the usual infrared Coulomb phase. For realistic form factors the integral

$$\int_{-4q_{ij}^2}^0 \frac{F_i(x)F_j(x)}{x - \lambda^2} dx$$

is convergent in the limit  $q_{ij} \rightarrow \infty$ , so in that case  $\text{Im } Y$  and  $\text{Im } L$  are proportional for large  $s_{ij}$ .

The real part of  $Y$  is given by the dispersion relation

$$Y(s_{ij}) = \frac{s_{ij} - (m_i - m_j)^2}{\pi} \int_{(s_0)_{ij}}^{\infty} \frac{\text{Im } Y(s' +)}{s' - (m_i - m_j)^2} \frac{ds'}{s' - s_{ij}}, \quad (\text{A.7})$$

and a similar relation gives  $L(s_{ij})$ . It follows that for realistic form factors  $Y$  and  $L$  become proportional for large  $|s_{ij}|$ .

The function  $L$  can be calculated explicitly and one finds [2, 4]

$$\begin{aligned} L &= -Z_i Z_j \frac{\alpha}{\pi} \left\{ 1 + \frac{z - \frac{1}{2}}{\sqrt{1-z}\sqrt{-z}} \ln \frac{\sqrt{1-z} + \sqrt{-z}}{\sqrt{1-z} - \sqrt{-z}} \right\} \\ &= -Z_i Z_j \frac{\alpha}{\pi} \left\{ 1 - \frac{2\theta}{\tan 2\theta} \right\}, \end{aligned} \quad (\text{A.8})$$

where

$$\sin^2 \theta = z = \frac{s_{ij} - (m_i - m_j)^2}{4m_i m_j}.$$

As in Ref. [4] we define

$$(D_{\mu\nu})_{ij} = \frac{\exp(LC - Y)}{\Gamma(1 - L)}, \tag{A.9}$$

where  $C$  is Euler's constant ( $C = 0.5772$ ). Since

$$\frac{\exp(LC)}{\Gamma(1 - L)} = 1 - \frac{(\pi L)^2}{12} + O(L^3) \tag{A.10}$$

this factor is only important near the threshold  $s_{ij} \simeq (s_0)_{ij}$ , where  $L$  is large. Near and above this threshold we have [4]

$$|(D_{\mu\nu})_{ij}|^2 \propto \frac{e^{2\pi\gamma_{ij}} - 1}{2\pi\gamma_{ij}}, \tag{A.11}$$

which is related to the Coulomb penetration factor. It is the behaviour (A.11) that ensures that the amplitude  $\bar{f}$  (cf. equation (2.6)) is finite on the physical sheet in a neighbourhood of  $(s_0)_{ij}$ . (If  $Z_i Z_j < 0$  there are weak Coulomb bound state poles for  $\gamma_{ij} = i(n + l)$ , ( $n = 1, 2, \dots$ ).

By equations (A.1), (A.9), and (A.10) we have to order  $\alpha$

$$D_{\mu\nu} = \exp(-Y_{\mu\nu}), \tag{A.12}$$

where

$$Y_{\mu\nu} = \sum_{i < j} (Y_{\mu\nu})_{ij}. \tag{A.13}$$

It also follows that as  $\lambda \rightarrow 0$

$$D_{\mu\nu} = O(1) \exp(L_{\mu\nu} \ln \lambda), \tag{A.14}$$

where

$$L_{\mu\nu} = \sum_{i < j} (L_{\mu\nu})_{ij}. \tag{A.15}$$

For point charges the function  $Y_{\mu\nu}$  has a simple origin. As discussed in Refs. [2] and [4] it arises from the sum of all Feynman graphs where a photon is exchanged between two external legs of the hadronic amplitude  $(f_H)_{\mu\nu}$ . If  $(f_H)_{\mu\nu}$  is taken to be constant in the integration region of the Feynman integrals, the sum is simply  $Y_{\mu\nu}(f_H)_{\mu\nu}$ .

It is clear from the definition of  $D_{\mu\nu}$  that it obeys crossing and is real analytic in the cut  $s$ -,  $t$ -, and  $u$ -planes.

### Appendix B

From (2.7) we see that the term

$$\mathcal{C} \equiv (\bar{S}_C)_l^{1/2} - 1, \tag{B.1}$$

which appears in (3.16), is given by

$$\mathcal{C} = \frac{1}{2}R + i\Sigma_l \quad (\text{B.2})$$

for  $\pi^+p$  scattering, and by

$$\mathcal{C} = -(\frac{1}{2}R + i\Sigma_l)P_- \quad (\text{B.3})$$

for  $\pi^-p$  scattering, where  $P_- = 1 - P_0$  is the projection on the  $\pi^-p$  state, and  $R$  is given by

$$e^R = |D_{\pi^+p, \pi^+p}(t=0)|. \quad (\text{B.4})$$

The explicit expressions for the corrections  $\Delta$  to  $\pi^-p$  scattering are obtained by combining (3.18) with (3.16);

$$\begin{aligned} \Delta = & -\frac{1}{2} \left\{ R + c_{ij} \left[ 1 - \left( \frac{q_-}{q_0} \right)^{2l+1} \right] \right\} A_{ij} \\ & - 2\Sigma_l B_{ij} + q_-^{2l+1} |\Lambda_i \Lambda_j|^{1/2} \text{Re } H_{ij}, \end{aligned} \quad (\text{B.5})$$

where  $ij = 11, 13,$  and  $33$  give  $\Delta_1, \Delta_{13},$  and  $\Delta_3$  respectively.<sup>3)</sup> Here

$$\begin{aligned} A_{ij} &= \sin(\delta_H^i + \delta_H^j) + \frac{1}{2}(\eta_H^i - \eta_H^j) \sin(\delta_H^i - \delta_H^j), \\ B_{ij} &= \sin \delta_H^i \sin \delta_H^j + \frac{1}{4}(\eta_H^i + \eta_H^j - 2) \cos(\delta_H^i - \delta_H^j), \\ c_{11} &= \frac{1}{2}, \quad c_{13} = -1, \quad c_{33} = 2, \end{aligned} \quad (\text{B.6})$$

and  $H_{ij}$  is defined by

$$\mathcal{H}_R = \frac{1}{3} \begin{pmatrix} -2H_{11} & \sqrt{2} H_{13} \\ \sqrt{2} H_{13} & -H_{33} \end{pmatrix}. \quad (\text{B.7})$$

The real part of  $H_{ij}$  is given by the dispersion relation (2.22), where the physical cut integral is determined from

$$\begin{aligned} q_-^{2l+1} |\Lambda_i \Lambda_j|^{1/2} \text{Im } H_{ij} = & - \left\{ R + c_{ij} \left[ 1 - \left( \frac{q_-}{q_0} \right)^{2l+1} \right] \right\} B_{ij} \\ & + \Sigma_l A_{ij} - |c_{ij}|^{1/2} \eta_{ij}, \end{aligned} \quad (\text{B.8})$$

where  $\eta_{ij}$  are the inelasticity corrections given in (3.10).

Equations (B.5) and (B.8) also hold for  $\pi^+p$  scattering if we put  $i = j = 3$ ,  $\mathcal{H}_R = H_{33}$ , and  $c_{33} = 0$  (cf. equations (3.51) and (3.52) in Ref. [4]).

## REFERENCES

- [1] J. HAMILTON, B. TROMBORG and I. ØVERBØ, Nucl. Phys. *B60*, 443 (1973).
- [2] B. TROMBORG and J. HAMILTON, Nucl. Phys. *B76*, 483 (1974).
- [3] J. HAMILTON, Fortschr. der Physik *23*, 211 (1975).
- [4] B. TROMBORG, S. WALDENSTRÖM, and I. ØVERBØ, Ann. Phys. (N.Y.) *100*, 1 (1976).
- [5] R. F. DASHEN and S. C. FRAUTSCHI, Phys. Rev. *135*, B1190, B1196 (1964); *137*, B1318 (1965).
- [6] E. SAUTER, Nuovo Cimento *61A*, 515 (1969); *6A*, 335 (1971).

<sup>3)</sup> For  $ij = 11$  and  $33$  the right-hand side of (B.5) really gives  $\eta_H^1 \Delta_1$  and  $\eta_H^3 \Delta_3$ . However, we are mainly concerned about the energy region below the inelastic threshold, where  $\eta_H^i = 1$ .



- [7] D. V. BUGG, Nucl. Phys. *B58*, 397 (1973).
- [8] J. R. CARTER, D. V. BUGG, and A. A. CARTER, Nucl. Phys. *B58*, 378 (1973).
- [9] G. C. OADES and G. RASCHE, Helv. Phys. Acta *44*, 160 (1971);  
H. ZIMMERMANN, Helv. Phys. Acta *47*, 130 (1974); *48*, 191 (1975);  
G. RASCHE and W. S. WOOLCOCK, Helv. Phys. Acta *49*, 435, 455, 557 (1976).
- [10] There is a comprehensive literature on potential theory for Coulomb plus hadronic potentials. We list only a few recent papers:  
A. GERSTEN, Nucl. Phys. *B103*, 465 (1976);  
F. S. ROIG and A. R. SWIFT, Nucl. Phys. *B104*, 533 (1976);  
H. VAN HAERINGEN, J. Math. Phys. *18*, 927 (1977).
- [11] B. TROMBORG, S. WALDENSTRØM and I. ØVERBØ, Phys. Rev. *D15*, 725 (1977).
- [12] G. EBEL et al., Nucl. Phys. *B33*, 317 (1971).
- [13] J. L. PETERSEN, Nucl. Phys. *B13*, 73 (1969);  
M. BLAŽEK, FYSIKALNY ČASOPIS *20*, 195 (1970).
- [14] G. RASCHE and W. S. WOOLCOCK, Fortschr. der Physik *25*, 501 (1977).
- [15] F. A. BERENDS, A. DONNACHIE and D. L. WEAVER, Nucl. Phys. *B4*, 1 (1967).
- [16] R. G. MOORHOUSE, H. OBERLACK and A. H. ROSENFELD, Phys. Rev. *D9*, 1 (1974).
- [17] M. ARMAN et al., Phys. Rev. Letters *29*, 962 (1972);  
D. SOBER et al., Phys. Rev. *D11*, 1017 (1975);  
K. C. LEUNG et al., Phys. Rev. *D14*, 698 (1976);  
B. M. K. NEFKENS and D. I. SOBER, Phys. Rev. *D14*, 2434 (1976).  
What we call the soft photon approximation is by the authors above called external emission dominance.
- [18] J. HAMILTON and B. TROMBORG, *Partial Wave Amplitudes and Resonance Poles* (Oxford Univ. Press 1972).
- [19] J. S. BALL et al., Phys. Rev. *177*, 2258 (1969); Phys. Rev. Letters *28*, 1143 (1972).
- [20] S. WALDENSTRØM, I. ØVERBØ and B. TROMBORG,  $\pi N$  Absorptive Electromagnetic Corrections (NORDITA Technical Notes, 1977).
- [21] G. BREIT, *Fundamental Interactions in Physics*. A. Perlmutter (ed.). (Plenum Press 1973), p. 143.
- [22] H. PILKUHN, Nucl. Phys. *B82*, 365 (1974);  
F. MYHRER and H. PILKUHN, Z. Physik *A276*, 29 (1976).
- [23] J. S. BALL and R. L. GOBLE, Phys. Rev. *D11*, 1171 (1975);  
S. S. VASAN, Nucl. Phys. *B106*, 535 (1976).
- [24] In the work by Sogard [25] and Borie [26] a somewhat different factor is extracted from the amplitude to give an infrared convergent nuclear amplitude. This means that our corrections to the differential cross sections, which were discussed in Ref. [11], differ from those given in Refs. [25] and [26].
- [25] M. R. SOGARD, Phys. Rev. *D9*, 1486 (1974).
- [26] E. Borie, Tables of radiative corrections to pion nucleon and nucleon-nucleon scattering, TKP 77-6, April 1977.