

Zeitschrift: IABSE reports = Rapports AIPC = IVBH Berichte
Band: 77 (1998)

Artikel: Modernisation and strengthening of large-panel building
Autor: Alexandrian, Eduard
DOI: <https://doi.org/10.5169/seals-58236>

Nutzungsbedingungen

Die ETH-Bibliothek ist die Anbieterin der digitalisierten Zeitschriften auf E-Periodica. Sie besitzt keine Urheberrechte an den Zeitschriften und ist nicht verantwortlich für deren Inhalte. Die Rechte liegen in der Regel bei den Herausgebern beziehungsweise den externen Rechteinhabern. Das Veröffentlichen von Bildern in Print- und Online-Publikationen sowie auf Social Media-Kanälen oder Webseiten ist nur mit vorheriger Genehmigung der Rechteinhaber erlaubt. [Mehr erfahren](#)

Conditions d'utilisation

L'ETH Library est le fournisseur des revues numérisées. Elle ne détient aucun droit d'auteur sur les revues et n'est pas responsable de leur contenu. En règle générale, les droits sont détenus par les éditeurs ou les détenteurs de droits externes. La reproduction d'images dans des publications imprimées ou en ligne ainsi que sur des canaux de médias sociaux ou des sites web n'est autorisée qu'avec l'accord préalable des détenteurs des droits. [En savoir plus](#)

Terms of use

The ETH Library is the provider of the digitised journals. It does not own any copyrights to the journals and is not responsible for their content. The rights usually lie with the publishers or the external rights holders. Publishing images in print and online publications, as well as on social media channels or websites, is only permitted with the prior consent of the rights holders. [Find out more](#)

Download PDF: 05.07.2025

ETH-Bibliothek Zürich, E-Periodica, <https://www.e-periodica.ch>



Modernisation and Strengthening of Large-Panel Building

Eduard ALEXANDRIAN
Head of the Laboratory
TbilZNIIEP
Tbilisi, Georgia



Eduard Alexandrian, born 1919, civil and industrial engineering, candidate of technical science. For over 30 years has studied the problems of strengthening and restoration of damaged buildings.

Summary

The paper describes modernisation of a large-panel building, series 1-335 in Krasnodar. Attention is paid to the structural solution of such buildings and the design drawbacks which resulted in significant corrosion of important joints of bearing structures, overnormative deflection of floor slabs, etc. The paper presents developed, tested and introduced solutions on elimination the drawbacks of the structure. Also considered are the questions of durability and reliability of epoxy mortars in construction based on the results of long-term studies of the author and observation over the operation of the buildings restored and strengthened by epoxy mortars.

1. Modernisation of Large-Panel Buildings, Series 1-335 in Krasnodar (Russia)

In the process of building and exploitation of large-panel buildings of series 1-335, one of the mass building series of the first generation in the former Soviet Union, an urgent necessity of solving a number of architectural and structural problems arose. Besides that these houses deteriorated and required overhaul repair and modernisation. The structure of these houses consists of outside wall panels and inside frame, the main elements of which - cross-bars - are supported by the columns spaced along the middle longitudinal axis of the building and by the outside bearing wall panels. The wall panel presents a thin ribbed slab 30 mm wide with warmth-keeping jacket of non steam cured foam concrete 300 mm wide. The load from the cross-bars to the outside wall panels is transferred through the cantilevers made of channels N12 embedded in the ribs of the panels with the cross-section 175 x 150. The floor slabs, width 100 mm, are supported from both sides by cross-bars, cross-section 200 x 350 mm.

Presented below are the solutions of a number of technical problems developed by TbilZNIIEP concerning the elimination of structural drawbacks in the buildings of series 1-335. The solutions were approved in Krasnodar (Russia) in 1989 in one of the first experiments in the Soviet Union on the Modernisation of large-panel buildings of the first generation.

1.1 Strengthening of the joints "Cross-Bars Supported by Wall Panels"

Examination of the buildings of series 1-335 after 10-12 years of operation in different towns revealed corrosion of load bearing embedded details of channels N12. In Leningrad, e.g., corrosion was 0.5 mm on the average on every open surface amounting to 1 mm in some

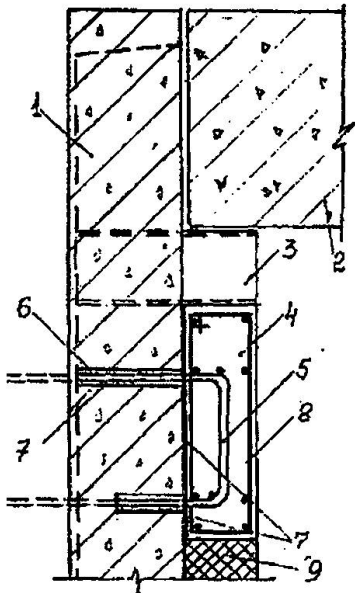

places. Corrosion of the embedded details was mainly due to the "bridges" of cold formed in double-layer panels due to the wrongly selected warmth-keeping jacket of non steam cured foam concrete of low strength, weak adhesion with reinforced concrete panel and high hygroscopicity. Taking into account the danger of exploitation of the buildings with such joints it was suggested that reinforced concrete monolithic or prefabricated columns 200 x 200 mm, height 2.20 m should be placed under existing cantilevers on each floor and additional foundation should be arranged with the column in the sub-floor // (LenZNIIEP). This method alongside with great labour expenditures was connected with the necessity of erection of long-size column elements through window openings. TbilZNIIEP has solved this problem by gluing prefabricated reinforced concrete elements - cantilevers to the wall panel ribs - by means of polymer mortar against the stop to the existing cantilevers. Anchor free lengths of cantilevers were glued into the pits previously drilled in the ribs (fig. 1).

Fig. 1 Strengthening of the joint 'cross-bars supported by wall panels'

1 - wall panel rib; 2 - cross-bar; 3 - channel No. 12; 4 - strengthening cantilever; 5 - anchor; 6 - pit, $d = 25$ mm; 7 - polymer mortar; 8 - cantilever reinforcement, 9 - warmth-keeping jacket-foam concrete

To fix the newly built loggias to the existing wall panels from the yard facade anchors of the cantilevers were roved through the pit in the rib and welded to the embedded details of the previously arranged vertical panels of loggias. Shear tests of a full-size reinforced concrete cantilever glued to the panel rib fragment showed that the patterns were damaged mainly in tile concrete close to the glue joint and anchor rupture. The bearing capacity of the strengthening structure was 1.5 - 2 times that of the designed one determined according to /3/ as the design of an embedded detail. Hence the design of anchor cross-section area of the strengthening cantilever can be analogous to he design of anchor cross-sections of embedded details /3/.

Having found the area and the diameter of the anchor - d and assuming the diameter of polymer mortar casing - d_0 it is possible to determine the length of the anchorage of free lengths of reinforcement bars of the cantilever - l by formula

$$l \geq \frac{d^2 R_s}{4d_0 R_{b,sh} \gamma_{bi}}$$

where R_s - designed stretch resistance of the reinforcement, $R_{b,sh}$ -actual strength of concrete: panel rib shear strength assumed to be $R_{b,sh} = 1.58 R_{br}$ where R_{br} -tensile strength of concrete