

2. The subgroup generated by involutions

Objektyp: **Chapter**

Zeitschrift: **L'Enseignement Mathématique**

Band (Jahr): **33 (1987)**

Heft 1-2: **L'ENSEIGNEMENT MATHÉMATIQUE**

PDF erstellt am: **20.09.2024**

Nutzungsbedingungen

Die ETH-Bibliothek ist Anbieterin der digitalisierten Zeitschriften. Sie besitzt keine Urheberrechte an den Inhalten der Zeitschriften. Die Rechte liegen in der Regel bei den Herausgebern.

Die auf der Plattform e-periodica veröffentlichten Dokumente stehen für nicht-kommerzielle Zwecke in Lehre und Forschung sowie für die private Nutzung frei zur Verfügung. Einzelne Dateien oder Ausdrucke aus diesem Angebot können zusammen mit diesen Nutzungsbedingungen und den korrekten Herkunftsbezeichnungen weitergegeben werden.

Das Veröffentlichen von Bildern in Print- und Online-Publikationen ist nur mit vorheriger Genehmigung der Rechteinhaber erlaubt. Die systematische Speicherung von Teilen des elektronischen Angebots auf anderen Servern bedarf ebenfalls des schriftlichen Einverständnisses der Rechteinhaber.

Haftungsausschluss

Alle Angaben erfolgen ohne Gewähr für Vollständigkeit oder Richtigkeit. Es wird keine Haftung übernommen für Schäden durch die Verwendung von Informationen aus diesem Online-Angebot oder durch das Fehlen von Informationen. Dies gilt auch für Inhalte Dritter, die über dieses Angebot zugänglich sind.

classification. For a complete exposition of Thurston's theory, we refer the reader to [4], and for more information on Teichmüller space, to [1]. Finally, in section 4, we prove the theorem on the type of the product of two involutions.

The problem of studying the types of products of involutions in the mapping class group was suggested to the second author by François Laudenbach. The theorem on the subgroup generated by involutions arose out of an attempt to obtain more precise information about the mapping classes which occur as products of two involutions.

The first author acknowledges partial support from Université René Descartes (Strasbourg), and the second author acknowledges support from CNRS (France) and Universidad Nacional Autónoma de México.

2. THE SUBGROUP GENERATED BY INVOLUTIONS

Let $M(F_g)$ denote the mapping class group of a closed orientable surface F_g of genus $g \geq 2$. Let $I(F_g)$ denote the subgroup of $M(F_g)$ which is generated by involutions. We wish to describe $I(F_g)$ as a subgroup of $M(F_g)$. Clearly $I(F_g)$ is a normal subgroup of $M(F_g)$. Hence, we shall give our description in terms of the quotient, $M(F_g)/I(F_g)$.

We begin by recalling some algebraic facts about $M(F_g)$. For a general introduction to the algebraic structure of $M(F_g)$, we refer the reader to [2].

It is a classical fact that $M(F_g)$ is generated by Dehn twists about nonseparating simple closed curves on M . In fact, $M(F_g)$ is generated by a finite number of such twists. The minimum number of twists which is required to generate $M(F_g)$ was given by Humphries [5].

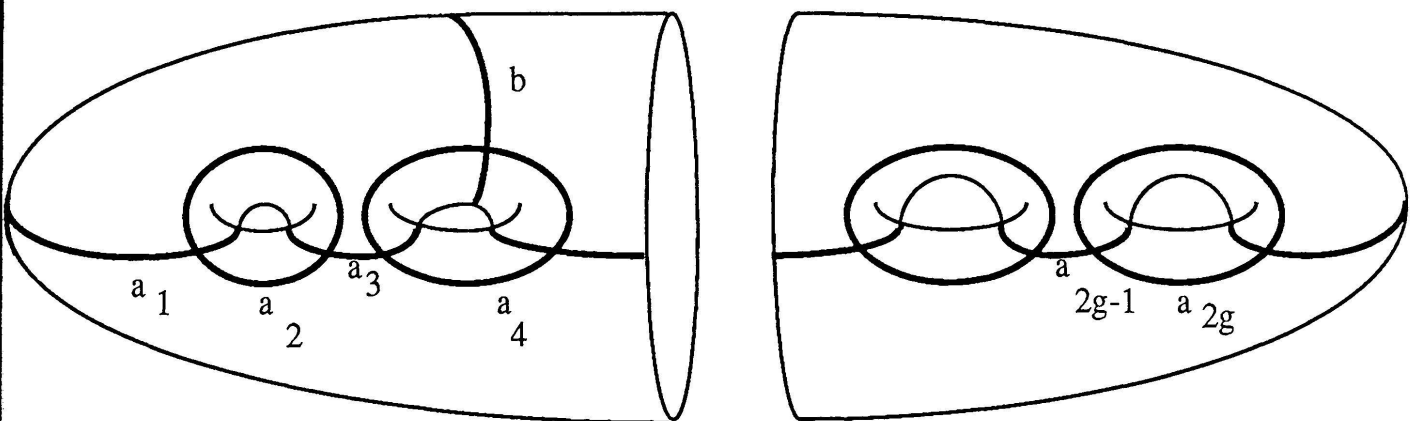

FIGURE 1.

THEOREM (Humphries). $M(F_g)$ is generated by the Dehn twists about the curves a_1, \dots, a_{2g} and b of figure 1.

Let us denote the Dehn twist about a curve, a , by t_a . (We remind the reader that the sense, right or left, of a Dehn twist is not dependent upon an orientation of the curve a , but rather upon the orientation of the surface; t_a denotes a right Dehn twist with respect to the given orientation on F .) Given any element of $M(F_g)$, h , we have the following identity:

$$(1) \quad ht_a h^{-1} = t_{h(a)}.$$

It follows that any two Dehn twists about nonseparating simple closed curves on F are conjugate in $M(F_g)$. As a consequence, $H_1(M(F_g))$ is cyclic. The order of $H_1(M(F_g))$ was computed by Powell [8]:

$$(2) \quad H_1(M(F_2)) = Z_{10},$$

$$(3) \quad H_1(M(F_g)) = 1, \quad \text{if } g \geq 3.$$

Due to the peculiar nature of genus 2, we shall need more precise information concerning involutions in $M(F_2)$. It is a consequence of a theorem of Nielsen (cf. [7]) that every involution in $M(F_2)$ is represented by an involution of F_2 . Hence, we need only describe involutions of F_2 .

There are two obvious such involutions. First, there is the hyperelliptic involution, i , with six fixed points which is depicted in figure 2 as a rotation by 180 degrees about the horizontal axis.

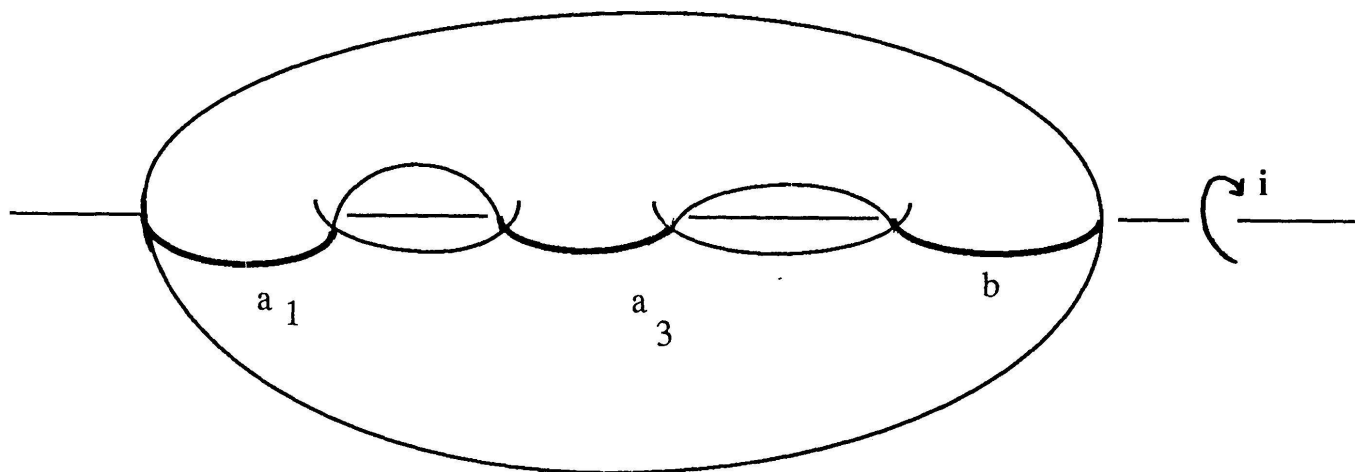

FIGURE 2.

Let us denote the Dehn twist along a_i by t_i . From equation (1), we see that i commutes with t_1, t_2, t_3, t_4 and t_b . Hence, i is a central element of $M(F_2)$.

The following identity was established by Birman [2]:

$$(4) \quad i = t_1 t_2 t_3 t_4 t_b^2 t_4 t_3 t_2 t_1.$$

Secondly, there is the involution, s , with two fixed points, obtained by a rotation about the vertical axis as in figure 3.

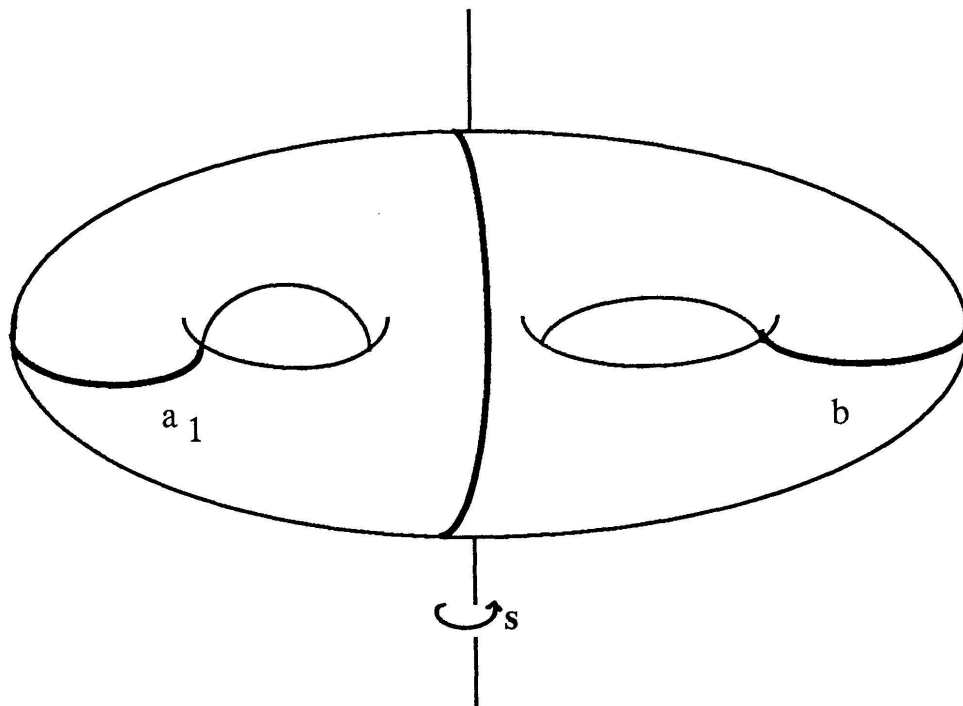

FIGURE 3.

We shall also need to express s as a product of Dehn twists. We thank Roger Tchangang Tambekou for explaining the technique used below for finding such an expression.

LEMMA 1. *We have*

$$s = t_3 t_2 t_4 t_3 t_2 t_4 t_1 t_b t_2 t_4 t_3 t_2 t_4 t_1 t_b.$$

Proof. Since s commutes with i , it induces a map, s' , on the quotient orbifold of F_2 by the action of i , N . N is a sphere with six distinguished points of index 2, as in figure 4.

The map, s' , is again a rotation. In particular, it fixes the point P which is indicated in figure 4. Hence, we can isotope s' in a neighborhood of the disk D (again indicated in figure 4). This isotopy lifts, in an obvious way, to M_2 . Hence, we may assume that s' fixes the disc D pointwise. Therefore, we may consider s' as a map of a six-punctured disc fixing the boundary. In other words, s' is a braid. It is easy to see that the corresponding geometric braid is that depicted in figure 5.

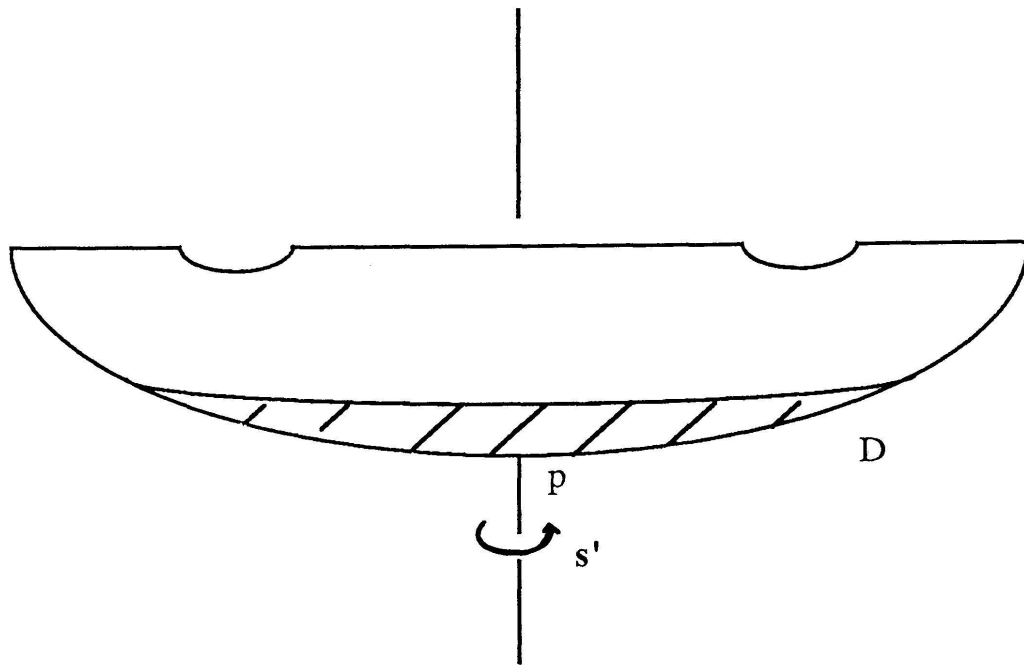

FIGURE 4.

Hence, in terms of the standard braid generators, we have

$$(5) \quad s' = s_3 s_2 s_4 s_3 s_2 s_4 s_1 s_5 s_2 s_4 s_3 s_2 s_4 s_1 s_5 .$$

As explained in [3], the braid generators s_1, s_2, s_3, s_4 and s_5 lift to t_1, t_2, t_3, t_4 and t_b respectively. Hence, we see that h is a lift of s' . It

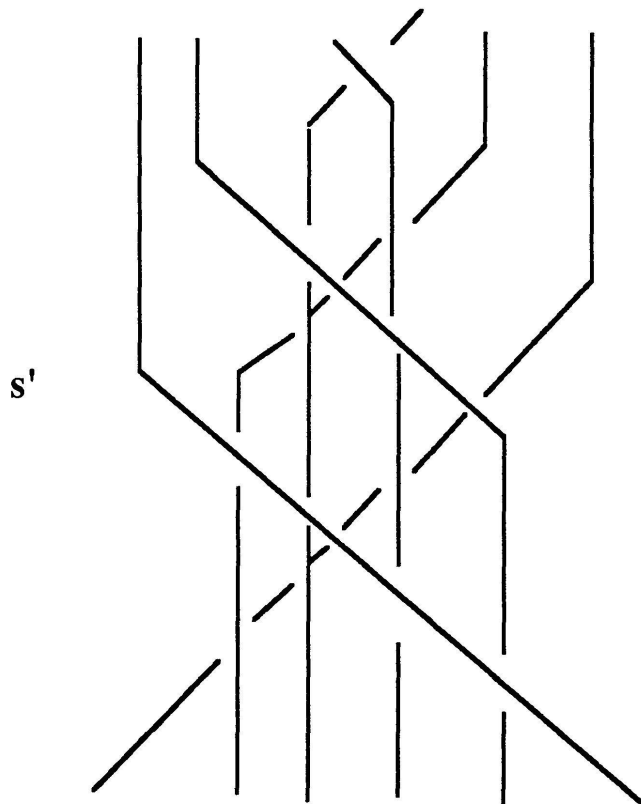

FIGURE 5.

follows that s is equal to h or $h \circ i$. Since i acts on $H_1(F_2, Z)$ as $-Id$, we may decide which of the two inequalities holds by considering the action of s and of h on $H_1(F_2, Z)$. We leave it to the reader to verify that s and h have the same action on $H_1(F_2, Z)$. This completes the proof of lemma 1.

We shall now show that every involution of F_2 is equivalent to either i or s .

LEMMA 2. *There are exactly two conjugacy classes of involutions in $M(F_2)$, the classes of i and of s .*

Proof. By equation (1) above, $st_1s^{-1} = t_b$.

Hence, s is not in the center of $M(F_2)$. Since i is central, i and s represent distinct conjugacy classes in $M(F_2)$.

It remains to see that all involutions in $M(F_2)$ are conjugate to either i or s .

Hence, suppose t is an involution in $M(F_2)$. Let t also denote a representative involution of F_2 . Of course, the orbit space of F_2 under the action of $gp(t)$, N , is the base space of a branched covering with total space F_2 . Hence, by the Riemann-Hurewicz formula, we have the following identity:

$$(6) \quad 2(X(N) - b) = X(F_2) - b'$$

where X denotes Euler characteristic,

b = number of branch points in N ,

and b' = number of branch points in F_2 .

Since this is a two-fold branched cover, we know that b' is equal to b . Hence, if we denote the genus of N by g , we obtain the formula:

$$(7) \quad 6 = 4g + b$$

From this, we obtain precisely two solutions:

$$(8) \quad (g=0, b=6) \quad \text{or} \quad (g=1, b=2).$$

Now, we know that the branched cover is a regular branched cover. Hence, it is determined by a representation of $\pi_1(N \setminus \sigma)$ onto Z_2 , where σ is the set of branch points.

By the definition of a branch point, we know that the representation must be nontrivial on loops encircling a branch point.

Suppose that g is zero. Since $\pi_1(N \setminus \sigma)$ is generated by such loops, there is only one such representation. Hence, t must be topologically conjugate to i .

Now suppose that g is one. $N \setminus \sigma$ is a twice-punctured torus. The representation of the group $\pi_1(N \setminus \sigma)$ onto Z_2 factors through $H_1(N \setminus \sigma, Z_2)$ which is a free Z_2 -module with basis (x, y, z) given by the loops depicted in figure 6.

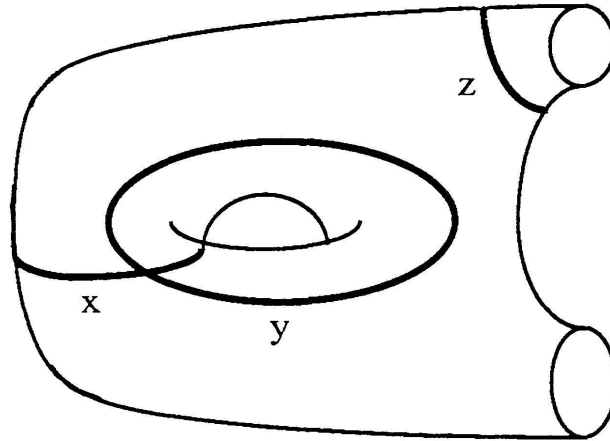

FIGURE 6.

Hence, there are four possible representations, given the previous restrictions:

- (9) (i) $(x, y, z) \rightarrow (0, 0, 1)$
- (ii) $(x, y, z) \rightarrow (1, 0, 1)$
- (iii) $(x, y, z) \rightarrow (0, 1, 1)$
- (iv) $(x, y, z) \rightarrow (1, 1, 1)$.

It suffices to show that these representations are topologically equivalent.

There is an homeomorphism, f , as depicted in figure 7, which acts as follows:

(10) $f : (x, y, z) \rightarrow (x, y + z, z)$.

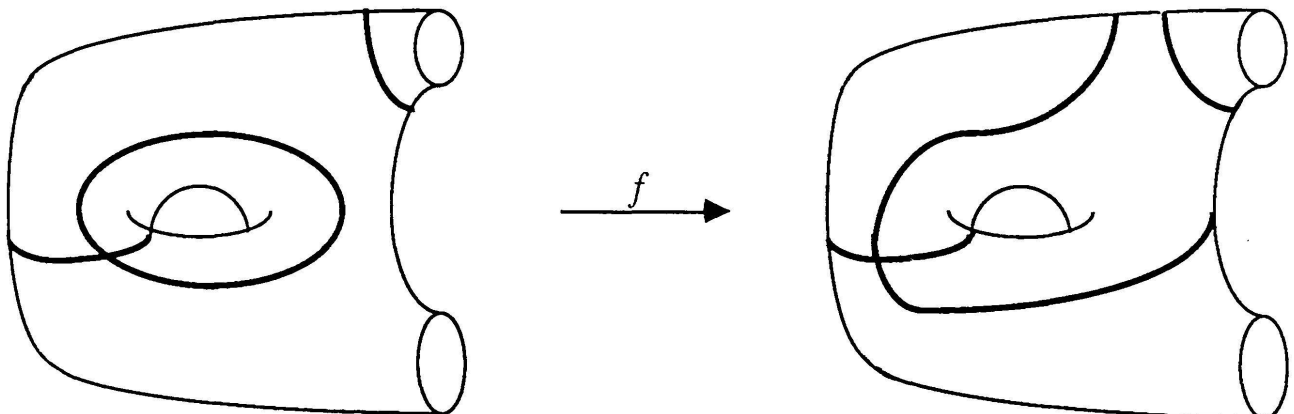

FIGURE 7.

Hence, (i) and (iii) are equivalent representations, and (i) and (iv) are equivalent representations. In a similar manner, by “pulling x over the puncture z ”, we see that (i) and (ii) are equivalent. Hence, all four representations are topologically equivalent.

It follows, as in the genus zero case, that t must be topologically conjugate to s . This completes the proof of lemma 2.

Let p be the abelianization map given by Powell's result:

$$(11) \quad \begin{aligned} p: M(F_2) &\rightarrow Z_{10} \\ t_d &\rightarrow 1, \quad d \text{ nonseparating.} \end{aligned}$$

From equation (4) and lemma 1, it follows that

$$(12) \quad p(i) = 1, \quad p(s) = 5.$$

From lemma 2, it follows that $p(I(F_2))$ is the subgroup of Z_{10} which is generated by Z_5 .

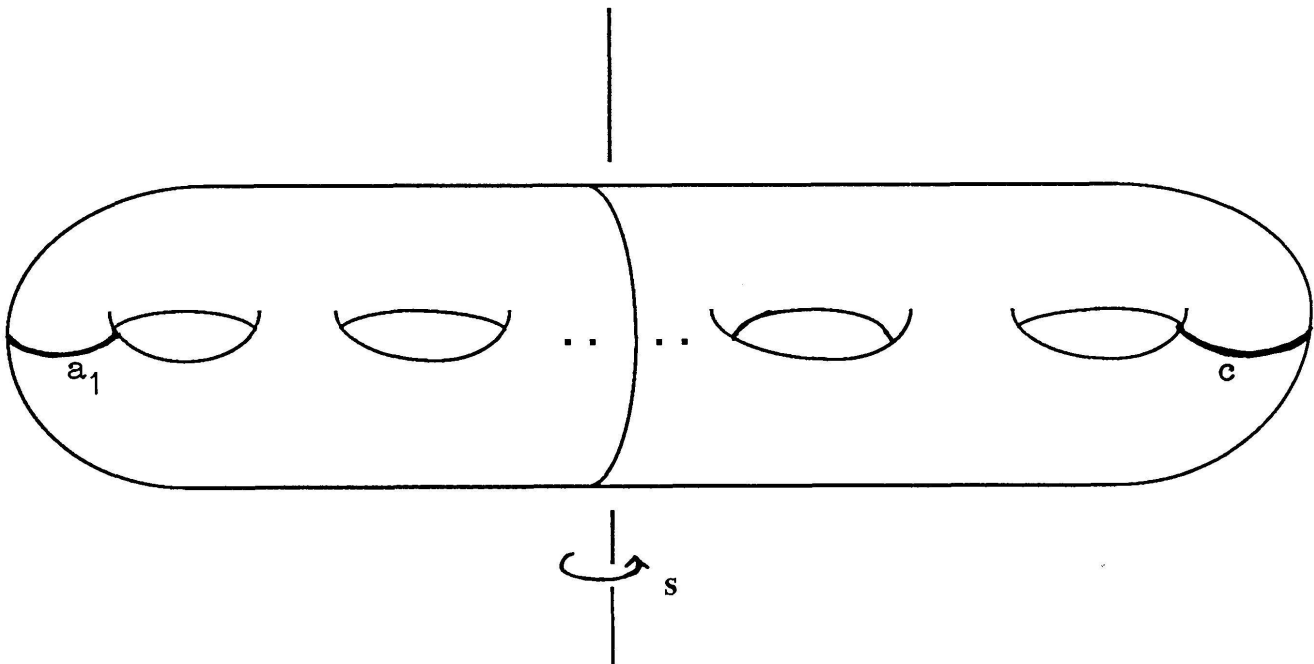

FIGURE 8.

For surfaces of even genus, s will continue to denote an involution with two fixed points as in figure 8. For surfaces of odd genus, s will denote an involution with four fixed points as in figure 9.

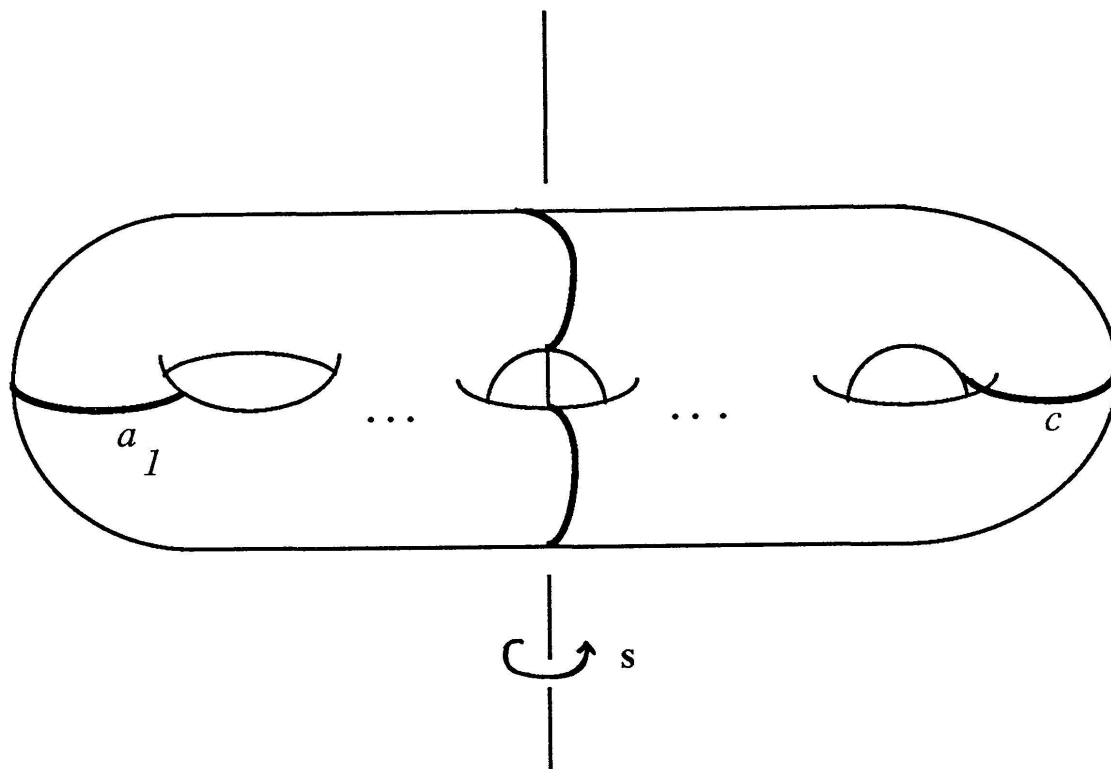

FIGURE 9.

We are now prepared to give the promised description of $I(F_g)$.

THEOREM 1.

- (a) $I(F_g)$ is normally generated by s for all $g \geq 2$.
- (b) $M(F_2)/I(F_2) = Z_5$.
- (c) $M(F_g)/I(F_g) = 1$, for all $g \geq 3$.

Proof. Let c denote the curve depicted in figure 8 or in figure 9, depending upon the genus, g . Let Σ be the normal closure of s . We begin by showing that $M(F_g)/\Sigma$ is cyclic.

Let t_i denote as before the Dehn twist along the curve a_i .

By equation (1), we conclude that:

$$(13) \quad t_c t_1^{-1} = (s t_1 s^{-1}) t_1^{-1} = s (t_1 s t_1^{-1}),$$

and this is an element of Σ .

For any j with $3 \leq j \leq 2g$, we may construct a homeomorphism, h , which takes (a_1, c) to (a_1, a_j) . By applying equation (1), we conclude that:

$$(14) \quad t_j t_1^{-1} \in \Sigma \quad \text{for all} \quad 3 \leq j \leq 2g.$$

By the same reasoning, we deduce that:

$$(15) \quad t_b t_1^{-1} \in \Sigma,$$

$$(16) \quad t_b t_2^{-1} \in \Sigma.$$

Hence, Humphries' generators are all conjugate modulo Σ . This implies that $M(F_g)/\Sigma$ is cyclic.

If the genus is greater than 2, equation (3) implies that $\Sigma = M(F_g)$. Since Σ is contained in $I(F_g)$, we see that $\Sigma = I(F_g) = M(F_g)$. Hence, theorem 1 is true for genus greater than two.

Now suppose that the genus is two. By equation (12), we conclude that i belongs to Σ . By lemma 2, it follows that $\Sigma = I(F_2)$. On the other hand, by equation (12), we conclude that

$$M(F_2)/\Sigma = Z_5.$$

This establishes theorem 1 for genus two.

This completes the proof of theorem 1.

3. THURSTON'S CLASSIFICATION OF MAPPING CLASSES

The Teichmüller space of F , denoted by \mathbf{T} , is the space of hyperbolic metrics on F up to isometry. It has a natural topology and is homeomorphic to an open ball of dimension $6g - 6 + 2b$, where g is the genus of F and b the number of its boundary components.

Thurston's boundary of \mathbf{T} is the space of projective classes of measured foliations on F .

A measured foliation is a foliation with isolated singularities of a special type (p -prong singularities, where p is any integer > 2 , see figure 10), with a measure on transverse segments which is a Lebesgue-measure, and which is invariant by isotopy of the segment keeping each point on the same leaf.

There's an equivalence relation between measured foliations, generated by isotopy and the operation of collapsing a leaf connecting two singular points. \mathbf{MF} denotes the space of equivalence classes.

There's a natural action on \mathbf{MF} by the positive reals; \mathbf{PMF} is the quotient projective space. \mathbf{PMF} is homeomorphic to a sphere of dimension $6g - 7 + 2b$ which constitutes, by Thurston's work, a natural boundary for Teichmüller space. $M(F)$, The mapping class group of F , acts continuously