

A diagnostic system with analogical inference and machine learning

Autor(en): **Tanaka, Shigenori / Mikami, Ichizou**

Objektyp: **Article**

Zeitschrift: **IABSE reports = Rapports AIPC = IVBH Berichte**

Band (Jahr): **72 (1995)**

PDF erstellt am: **26.09.2024**

Persistenter Link: <https://doi.org/10.5169/seals-54662>

Nutzungsbedingungen

Die ETH-Bibliothek ist Anbieterin der digitalisierten Zeitschriften. Sie besitzt keine Urheberrechte an den Inhalten der Zeitschriften. Die Rechte liegen in der Regel bei den Herausgebern.

Die auf der Plattform e-periodica veröffentlichten Dokumente stehen für nicht-kommerzielle Zwecke in Lehre und Forschung sowie für die private Nutzung frei zur Verfügung. Einzelne Dateien oder Ausdrucke aus diesem Angebot können zusammen mit diesen Nutzungsbedingungen und den korrekten Herkunftsbezeichnungen weitergegeben werden.

Das Veröffentlichen von Bildern in Print- und Online-Publikationen ist nur mit vorheriger Genehmigung der Rechteinhaber erlaubt. Die systematische Speicherung von Teilen des elektronischen Angebots auf anderen Servern bedarf ebenfalls des schriftlichen Einverständnisses der Rechteinhaber.

Haftungsausschluss

Alle Angaben erfolgen ohne Gewähr für Vollständigkeit oder Richtigkeit. Es wird keine Haftung übernommen für Schäden durch die Verwendung von Informationen aus diesem Online-Angebot oder durch das Fehlen von Informationen. Dies gilt auch für Inhalte Dritter, die über dieses Angebot zugänglich sind.

A Diagnostic System with Analogical Inference and Machine Learning

Système d'évaluation avec inférence analogique et apprentissage-machine
Ein Diagnosesystem mit analogem Schliessen und Maschinenlernen

Shigenori TANAKA

Lecturer
Kansai University
Osaka, Japan

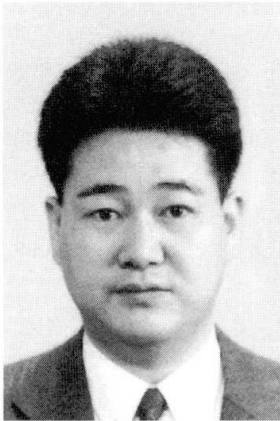

Shigenori Tanaka, born 1963, got his MS degree in civil eng. from Kansai Univ., Osaka. For ten years he has specialised in diagnostic knowledge-based expert systems in bridge engineering. He has a great interest in the reasoning and learning mechanism in knowledge engineering.

Ichizou MIKAMI

Prof.
Kansai University
Osaka, Japan



Ichizou Mikami, born 1939, received his Dr of Eng. degree from Nagoya University. For ten years he has been involved in expert systems for the maintenance of steel bridges. Ichizou Mikami has specialized in the construction and design on steel bridges since 1961.

SUMMARY

Expert systems are essential for the maintenance of existing civil engineering structures, because a wide range of expert engineering knowledge is required for such maintenance. This contribution is based on research for the development of a system to select methods for retrofitting fatigue cracking in steel bridges. Ideas for the further development of this system are presented with regard to knowledge, inference, and machine learning. Knowledge is enlarged by incorporating information concerning 75 additional cases. With this new knowledge base, the system can perform analogical inference, being equipped with an inference engine capable of greater machine learning, able to learn both positive and negative examples. The present system is capable of giving appropriate inference results.

RÉSUMÉ

Les systèmes experts sont essentiels à la bonne maintenance de constructions de génie civil, car celles-ci requièrent de grandes connaissances spécialisées. Poursuivant une recherche commencée sur l'aide au choix de moyens de réparation dans les fissures de fatigue des ponts métalliques, l'article traite d'une base de connaissances, d'inférences et d'apprentissage-machine. Grâce à 75 nouvelles études de cas, de nombreuses informations et connaissances ont pu être recueillies. Le système développé peut réaliser des inférences analogiques et prendre en compte des expériences négatives et positives. Les résultats obtenus sont encourageants.

ZUSAMMENFASSUNG

Expertensysteme sind beim Unterhalt bestehender Bauwerke besonders wichtig, da dafür ein breites Spektrum an Erfahrungswissen nötig ist. Aufbauend auf einem früheren Beitrag über die Unterstützung bei der Wahl von Reparaturmassnahmen für Ermüdungsrisse in Stahlbrücken wird die Weiterentwicklung des Systems in bezug auf die Wissensbasis, Schliessen und Maschinenlernen beschrieben. Dank 75 neuer Fallstudien und einer Inference-Maschine kann das System nun analog Schliessen und positive wie negative Beispiele lernen.



1. Introduction

Recently, the maintenance of existing civil engineering structures has become a very important subject. Since such maintenance requires engineers with ample experiential knowledge that has not yet been systematized, expert systems may be effectively used in this field.

The authors have previously developed an expert system for treating fatigue damage in steel bridges. The knowledge included in the knowledge-base was obtained from 90 cases of fatigue damage in existing steel bridges reported by Fisher(1984). To improve this system, Mikami et al.(1990, 1991) have developed an inference engine that combines a knowledge-based network model with a learning ability based on the theory of machine learning reported by Michalski et al.(1983). The learning ability is based partly on the truth maintenance system algorithm reported by Doyle(1979).

An expert system is summarized for selecting reasonable methods for retrofitting fatigue cracking in steel bridges, as reported by Mikami et al.(1994). The system uses a knowledge-based network model, which has a learning ability. The present paper reports our revision of this previous system with respect to all of its three phases; knowledge, inference, and learning.

With regard to the first phase, to complete the knowledge-base the number of actual cases of fatigue damage has been increased to 165; and this information is now used to define production relations having either positive or negative certainty factors for actual cases in the knowledge-base. The knowledge representation using the included relations is introduced, and new causal relations are generated. With regard to the second phase, the ability of the inference engine has been improved, and analogical inference is made possible. With regard to the third phase, the inference engine not only has the capability for positive learning that brings inference results closer to a positive correct answer, but also for negative learning that brings inference results closer to a negative correct answer.

2. Aim of the System

The knowledge-base, creating new causal relations, improving the inference functions, and further developing the learning mechanisms. More specifically, these improvements can be summarized as follows. We have tried to improve on the previous system reported by Mikami et al.(1994) by enlarging.

2.1 Enlargement of the knowledge-base

In the previous system, the knowledge was acquired from 90 cases as reported by Fisher, and was represented by causal relations. A causal relation was defined even if there was only a single past case to which it corresponded. The causal relation between two hypotheses was expressed using the relation from cause to conclusion. In light of these limitations in the knowledge-base, the following techniques were used to improve the quality of the knowledge-base.

2.1.1 Weighting causal relations

The previous system used four types of certainty factor represented by necessity, high possibility, possibility, or low possibility for the relations between cause and conclusion in expressing the degree of certainty with which a conclusion could be arrived at from a given cause. All the relations defined in the knowledge-base were, however, actually expressed by only one type of weight, possibility.

In the present system, the certainty factor of causal relations was weighted according to the number of cases in the collected data corresponding to a given relation, and to the year when the damage was discovered since the choice of retrofitting methods will have been made in the light of the most advanced technology at the time of discovery.

2.1.2 Handling of unknown causal relations

While in the previous system, causal relations of unknown existence are added to the knowledge-base as the knowledge that "If the condition is hypothesis A, then the conclusion is not hypoth-

esis B", in the present system these additional relations were, endowed with a low certainty factor, because there is no information clearly denying their possibility.

2.1.3 Expression of inclusive relations

In the knowledge-base of the previous system, the knowledge was expressed as causal relations between cause and conclusion, but not between causes and other causes or between conclusions and other conclusions. In the new system, the possibility of causal relations between causes and between conclusions has been included. Consider the case where hypothesis α is affirmed and hypothesis β is also affirmed. This included relation is defined in the new system as "if α , then β is necessary". A more complex case is illustrated in Fig. 1(a). There we see that "If ζ , then η is necessary", "if α , then β and γ are both necessary", and "if γ , then δ and ϵ are both necessary".

2.2 Creation of new causal relations

In the previous system, a knowledge-based model was produced when reverse, inversed, and contraposition relations could be generated, as shown in Table 1, from the causal relations defined in the knowledge-base.

In the present system, however, new necessity relations are generated from the included relations there determined. For example, if included relations are defined as shown in Fig. 1(a), the necessity relations can be generated as shown in Fig. 1(b). Furthermore, for these generated relations, the reverse, inversed, and contraposition relations based on the rules shown in Table 1.

2.3 Improvement of inference functions

When observed facts are inputted, the knowledge-based model is traced. With the present system, analogical inference is also carried out, since such inference is also carried out by tracing the relations generated from these included relations.

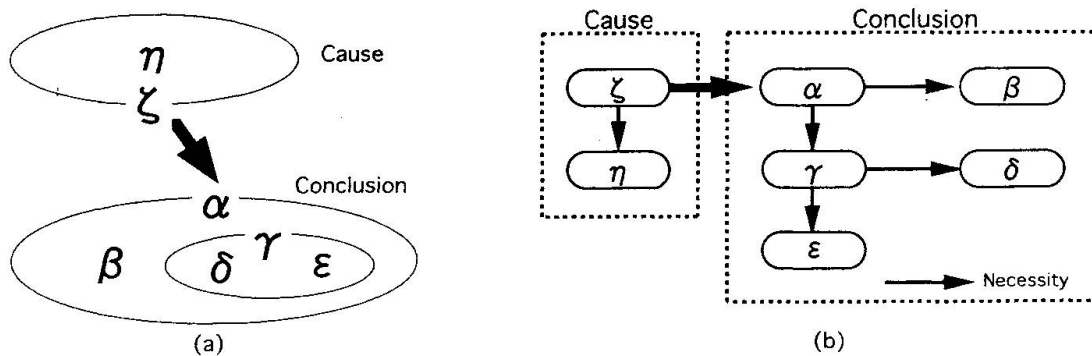

Fig. 1. Relation Generated by Inclusion Property

Table 1. Defined Relation and Generated Relation

| Defined relation (1) | Reverse relation (2) | Inversed relation (3) | Contraposition relation (4) |
|-------------------------|-------------------------|-------------------------------|-----------------------------------|
| $A - N \rightarrow B$ | $A \leftarrow P - B$ | Not A $- P \rightarrow$ Not B | Not A $\leftarrow N -$ Not B |
| $A - H \rightarrow B$ | $A \leftarrow P - B$ | - | - |
| $A - P \rightarrow B$ | $A \leftarrow P - B$ | - | - |
| $A - L \rightarrow B$ | $A \leftarrow L - B$ | - | - |

Note: Certainty factors :: N;Necessity, H;High possibility, P;Possibility, L;Low possibility.



2.4 Improvement of learning mechanisms

The previous system could learn through teaching correct answers, and this learning mechanism using a teacher made possible an increase of the relations having a certainty factor between two hypotheses so as to reduce the gap between inference results and correct answers. This process is called "Positive learning".

Through such positive learning, the certainty factor of all probable relations was thus increased, and all the probable solutions obtained from observed facts were inferred. To prevent overinference, however, the new system was also endowed with "Negative learning". Negative learning can remove undesirable inference results, if an answer negating the inference results is given.

3. Arrangement and Effective Utilization of Knowledge

3.1 Causal relations having a certainty factor

By using 165 past cases of cracking, it is possible to weight the relations between two hypotheses according to proximity between the year when each of the relevant cases of fatigue damage was detected, and the number of such cases. In order to carry out this weighting, all of the relations are divided into three groups: those detected before 1969, those between 1970 and 1979, and those detected since 1980. The cases whose years of detection are unknown were placed in the first group. Each case belonging to the first group is allotted one point, each belonging to the second group two points, and each belonging to the third group three points. The cases corresponding to a causal relation are detected, and then the sum of the points allotted to these cases is computed. This total indicates the effective extent of the causal relation in question. The table shown in Fig. 2 shows the frequency of each effective extent, which is the number of the actual causal relations having each effective extent. This data can be represented graphically by taking the effective extent as the abscissa and the cumulated relative frequency as the ordinate, as shown in Fig. 2.

Because the relation between the effective extent and the cumulated relative frequency can approximate an exponential distribution, the abscissa is divided based on a geometric series. Here, the abscissa is divided by 5, 10, and 20 points, and the relations with effective extent of 1~5, 6~10, 11~20, and more than 21 are defined as "low possibility", "possibility", "high possibility", and "necessity", respectively. The results of this weighting are shown in Tables 2 and 3, where the symbol \rightarrow indicates the direction of relation. The Retrofitting Methods are shown in Table 4 and the Typical Joints in Fig. 3, as reported by Mikami et al.(1994).

3.2 Handling of unknown causal relations

In section 3.1, relations with effective extent of 0 represent those not borne out by any actual case. Such relations are regarded as nonexistent, and are represented in the knowledge base as relations with a negated conclusion, there being allotted to them the lowest possible type of certainty factor, that of "low possibility".

3.3 Arrangement of knowledge with included relations

In the previous system, the causes of cracking were divided into external and internal ones. Because it is possible to express these by using included relations, the causal and included relations are defined as shown in Fig. 4.

4. Improvements of the Inference Engine

4.1 Modality interpretation

In the previous system, if both the status of a given condition and the weight of the relation were low, that condition exerted no influence upon the conclusion, when the modality interpretation

was carried out. In the system, the conclusion is influenced by the condition in the manner shown in Table 5, as reported by Mikami et al.(1994).

4.2 Interpretation of included relations

If included relations are defined in the knowledge-base, it becomes possible to generate new causal relations. In the network thus constituted, causal relations between two hypotheses and relations generated from included relations are called "trunk" and "branch", respectively. When the observed facts are inputted to the constituted network, the network is traced in a manner distinguishing between trunk and branch; and, while each trunk is always traced, each branch is traced only when the tracing has been found necessary, according to the location of the fact.

For example, if a fact is inputted to γ in Fig. 1(b), the relation of " $\alpha \rightarrow \beta$ " remains untraced. Because γ exists as an observed fact, hypothesis β is on same level as γ , and need not be inferred. On the other hand, both the relations " $\gamma \rightarrow \delta$ " and " $\gamma \rightarrow \varepsilon$ " are traced and inferred from γ . Because it is unknown whether "if γ then δ " or "if γ then ε " is true, it is necessary to trace both branches, and to carry out inference.

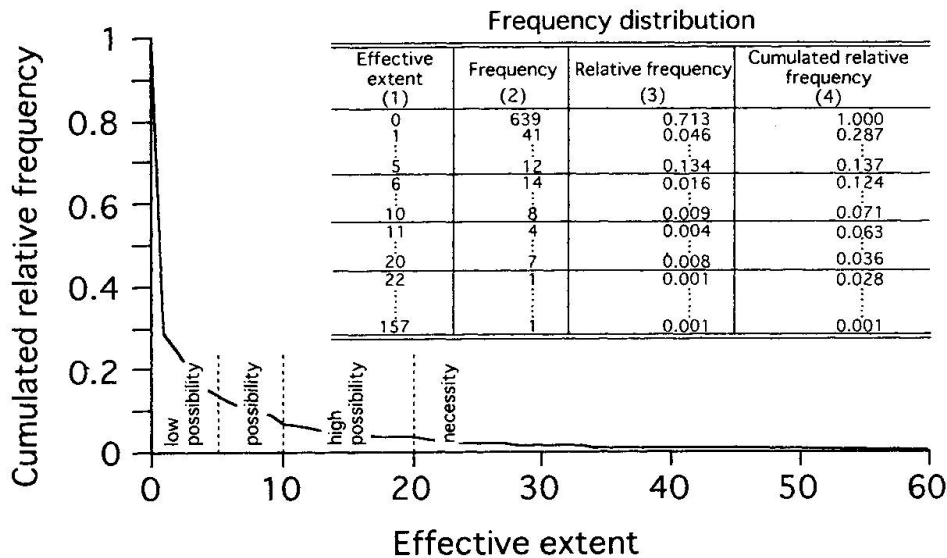

Fig. 2. Relation between Effective Extent and Cumulated Relative Frequency

Table 2. Causal Relations between Causes of Cracking and Joint Action

| Joint action | Cause of cracking | | | | | | | | | | | | | | |
|--------------|----------------------------|---|---|---|---|---|---|---|---|---|---|----------------------------|---|---|---|
| | External cause of cracking | | | | | | | | | | | Internal cause of cracking | | | |
| | A | B | C | D | E | F | G | H | I | J | K | L | M | N | O |
| 1 | | | | | | | | | | | | | | | |
| 2 | P | P | | | N | H | L | | L | | | H | N | P | L |
| 3 | | N | L | | N | N | P | L | L | | P | L | N | N | P |
| 4 | | | | | | | | | | | | | | | |
| 5 | | | | | | | | | | | | | | | |
| 6 | | | | | | P | | | | | | | | P | |
| 7 | L | L | | | | L | | | L | L | | P | | L | L |
| 8 | | | | | | | | | | | | | | | |
| 9 | | | | | | | | L | H | | | H | | | |
| 10 | | | | L | | | | | L | | | L | | | |
| 11 | | | | | | | | | | | | | | | |
| 12 | | P | | | L | | | L | L | | | P | | L | |
| 13 | | | | | P | | | | | | | | P | | |

Note : Certainly Factors :: N;Necessity, H;High possibility, P;Possibility, L;Low possibility.



Table 3. Causal Relation between Damage Factors and Retrofitting Methods

| Damage factor | Retrofitting methods | | | | | | | | | | | | | | | | | | | | | | | | |
|-----------------------------------|----------------------------------|---|---|---|---|---|---|---|---|----|----|----|----|----|----|----|----|----|----|----|----|----|----|----|---|
| | 1 | 2 | 3 | 4 | 5 | 6 | 7 | 8 | 9 | 10 | 11 | 12 | 13 | 14 | 15 | 16 | 17 | 18 | 19 | 20 | 21 | 22 | 23 | 24 | |
| External cause of cracking | | | | | | | | | | | | | | | | | | | | | | | | | |
| A | Vibration due to wind | | | L | | | | L | | | | L | L | | L | | | | | | | | | L | |
| B | Live load | H | | H | L | | | N | | L | | H | N | | | | | | | | | | L | | |
| C | Vibration due to earthquake | | | | | | | | | | | | | | | | | | | | | | | | |
| D | Low temperature | L | | | | | L | | | | | | | | L | | | | | | | | | | |
| E | Load distribution | P | H | | | L | | N | | | | P | L | | | N | P | | | | | | L | | |
| F | Defect of structural detail | N | N | | | L | L | N | P | | | P | H | | | P | P | L | L | L | | | | L | |
| G | Secondary deformation | P | | | | | | | | | | | L | | | | | | | | | | | | |
| H | Inferior quality of the material | | L | | | | | L | | | | L | L | | | | | | | | | | | | |
| I | Welding defect | H | L | P | L | | | L | P | | L | | P | P | L | | | | | | | | L | | |
| J | Fabrication error | | | | | | | | | | | | | | | | | | | | | | | L | L |
| K | Shipping and handling | P | | P | | | | | | | | | L | | | | | | | | | | | | |
| Internal cause of cracking | | | | | | | | | | | | | | | | | | | | | | | | | |
| L | Stress concentration | P | P | P | L | | | L | H | | L | | H | P | L | L | | | | | | L | L | L | L |
| M | Secondary stress concentration | N | N | L | | P | | N | P | | | P | L | | | N | P | L | L | | | | | | |
| N | Secondary stress | N | | N | | | | H | | | | N | H | | | | | | | | | | | | |
| O | Secondary stress due to buckling | L | | | | L | | | | | L | P | P | | | | | | | | | | | L | |
| P | Residual stress | | | | | | | | | | | | | | | | | | | | | | | | |
| Joint action | | | | | | | | | | | | | | | | | | | | | | | | | |
| 1 | Joint action 1 | | | | | | | | | | | | | | | | | | | | | | | | |
| 2 | Joint action 2 | H | P | P | L | L | | H | L | | | H | P | | L | H | L | | | | | L | | | |
| 3 | Joint action 3 | N | H | H | | L | L | N | P | | L | N | H | | H | L | L | L | | | | | | L | |
| 4 | Joint action 4 | | | | | | | | | | | | | | | | | | | | | | | | |
| 5 | Joint action 5 | | | | | | | | | | | | | | | | | | | | | | | | |
| 6 | Joint action 6 | | | | | | | | | | | | | | | | | | | | | | | | |
| 7 | Joint action 7 | L | | P | L | | | L | | | | L | L | | | | | | | | | | | L | L |
| 8 | Joint action 8 | | | | | | | | | | | | | | | | | | | | | | | | |
| 9 | Joint action 9 | L | L | | | | | L | | | | P | L | | | | | | | | | | | | |
| 10 | Joint action 10 | | | | | | | L | | | | | L | | | | | | | | | | | | |
| 11 | Joint action 11 | | | | | | | | | | | | | | | | | | | | | | | | |
| 12 | Joint action 12 | | | | L | | | | | L | | L | | | | | | | | | | | L | L | |
| 13 | Joint action 13 | | | | | | | P | | | | | | | | | | | | | | | | | |
| Cracking mode | | | | | | | | | | | | | | | | | | | | | | | | | |
| (a) | Mode (a) | P | L | | | | | L | | | | | | | | | | | | | | | | | |
| (b) | Mode (b) | H | | P | | | | N | L | | | P | P | | | P | | | | | | | | | |
| (c) | Mode (c) | H | H | L | | L | L | H | L | | L | H | P | | L | H | P | | | | | | L | L | |
| (d) | Mode (d) | H | L | H | L | L | | P | L | | | P | L | | | L | | L | L | L | | | | L | |
| (e) | Mode (e) | | | | | | | | | | | | | | | | | | | | | | | | |
| (f) | Mode (f) | H | | L | L | | | L | L | | | L | L | | L | | | | | | | | | | |
| (g) | Mode (g) | | | | | | | L | | | | | | | L | | | | | | | | | | |
| (h) | Mode (h) | L | L | | | | | L | | | | P | L | | | | | | | | | | | | |
| (i) | Mode (i) | | | | L | | | P | L | | L | | | | | | | | | | | | L | | |
| (j) | Mode (j) | | | | | | | | | | | | | | | | | | | | | | | L | |
| (k) | Mode (k) | | | | | | | | | | | | | | | | | | | | | | | | |
| (l) | Mode (l) | | | | | | | | | | | | | | | | | | | | | | | | |

Note : Certainly Factors :: N;Necessity, H;High possibility, P;Possibility, L;Low possibility.

Table 4. Retrofitting Methods

| Number (1) | Retrofitting method (2) | Number (1) | Retrofitting method (2) | Number (1) | Retrofitting method (2) |
|------------|-------------------------|------------|----------------------------------------|------------|---------------------------------------|
| 1 | Stop hole | 9 | Welding flange to stiffeners | 17 | Connecting main girder with bracing |
| 2 | Gouging | 10 | Remelting | 18 | Connecting main girder with diaphragm |
| 3 | Grinding | 11 | Splice plate with stiffeners | 19 | Connecting arch rib with floor beam |
| 4 | Peening | 12 | High tension bolt | 20 | Replacement of shoe |
| 5 | Lengthening web gaps | 13 | Splice plate | 21 | Replacement of main girder |
| 6 | Extending web thickness | 14 | Insert plate | 22 | Replacement of splice plate |
| 7 | Coring | 15 | Tied by cable | 23 | New stiffeners |
| 8 | Rewelding | 16 | Connecting main girder with floor beam | 24 | Vibration proof (e.g., damper) |

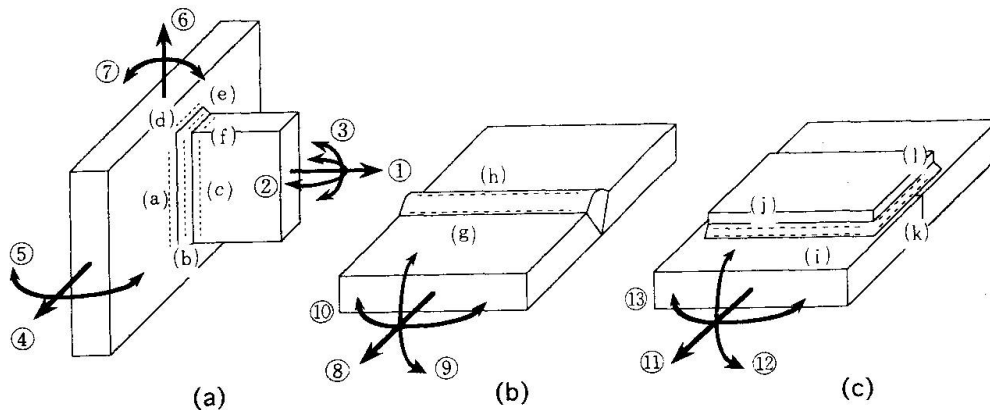

Fig. 3. Joint Action and Cracking Modes on Typical Joints; (a) Tee Joint; (b) Butt Joint; (c) Lap Joint

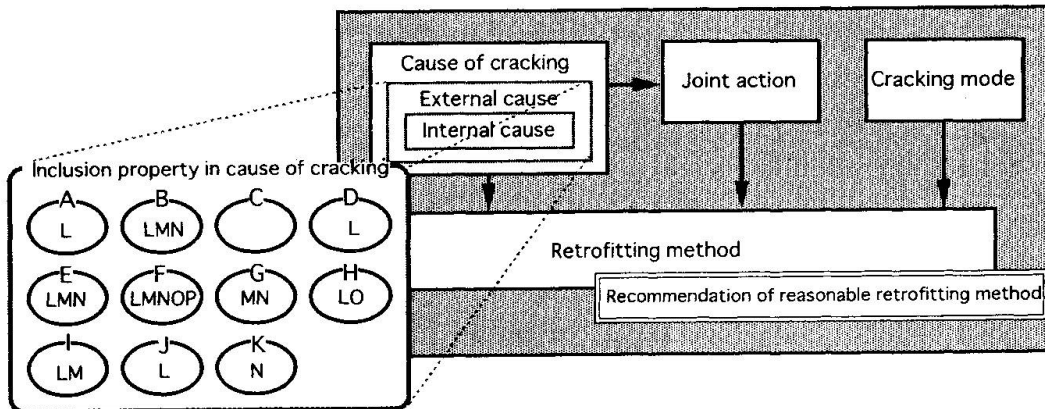

Fig. 4. A Causal Network Model for Reasoning Concerning the Retrofitting Method

Table 5. Status of Hypothesis of Conclusion

| Status of hypothesis of condition A (1) | Status of hypothesis of conclusion B | | | |
|-----------------------------------------|--------------------------------------|------------------|-------------|-----------------|
| | A-N→B (2) | A-H→B (3) | A-P→B (4) | A-L→B (5) |
| Fact | Necessity | High possibility | Possibility | Low possibility |
| Necessity | Necessity | High possibility | Possibility | Low possibility |
| High Possibility | High possibility | Possibility | Possibility | Low possibility |
| Possibility | Possibility | Possibility | Possibility | - |
| Low Possibility | Low possibility | Low possibility | - | - |
| Unknown | - | - | - | - |

Note : Certainly Factors :: N;Necessity, H;High possibility, P;Possibility, L;Low possibility.

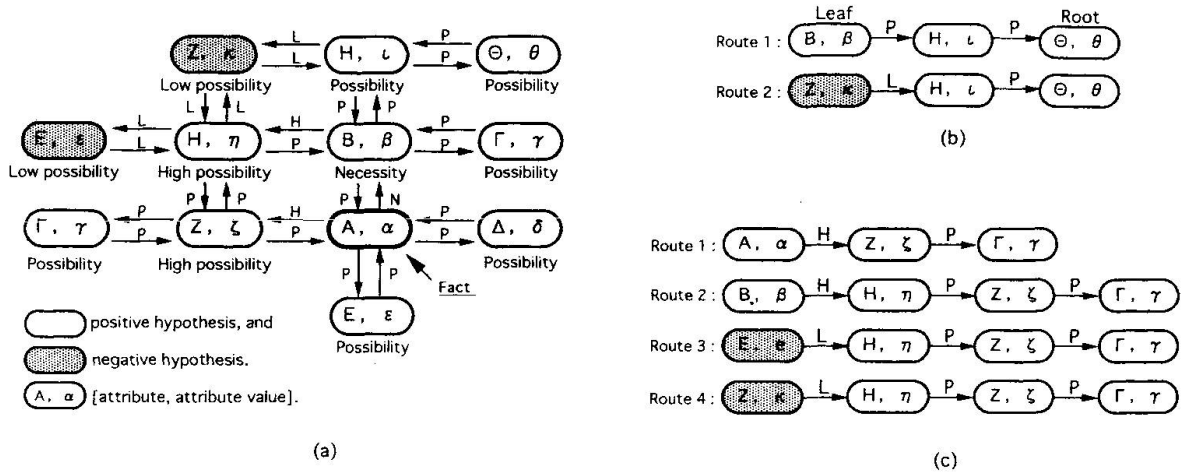

Fig. 5. Hypotheses Determined in A Network Model and Routes Obtained by Backtracking State Interpretation

4.3 Interpretation of learning with a teacher

Learning with a teacher is classified into "positive learning" and "negative learning". In the case of positive learning, the authenticity of given correct answers is positive, while in the case of negative learning, that authenticity is negative. In the case of either type of learning, it is necessary to distinguish whether the inferred hypotheses being given with the correct answer have positive or negative authenticity.

The process of learning is explained using the simple model shown in Fig. 5(a), as follows. It is assumed that a fact is inputted into the hypothesis [A, α], and then an inference result is obtained as shown in Fig. 5(a), where [A, α] indicates [attribute value].

4.3.1 Positive learning

(1) Hypotheses with positive authenticity

When a hypothesis of the correct answer is inferred as positive authenticity, the backtracking state interpretation reported by Mikami et al.(1994) is carried out from that hypothesis as the root, and the search reaching as far as the leaves. When all the leaves have been searched, the backtracking finishes. Hypotheses having the status of either fact or necessity or else terminating the network are the leaves. The route reaching a leaf with the status of either fact or necessity should carry out learning, and therefore the weights of each of the relations constituting that route are raised by one rank, those relations including ones that form part of both learning and non-learning routes. Hypotheses having either an attribute identical to that of the correct answer, or else an attribute that has already been traced once, are not retraced, as long as they have the same authenticity.

For example, let us suppose that a correct answer [Θ, θ] is given, as shown is Fig. 5(a). Because the relations extending in the rootward direction are the object of learning, as shown in Fig.5(b), two routes running from the root [Θ, θ] are to be found. And since, of these, Route 1 is that by which the learning is to be carried out, the weight of each of the relations constituting Route 1 is raised by one rank. Route 2, on the other hand, stops at the hypothesis [Z, κ], because the attribute H has already been traced.

(2) Hypotheses with negative authenticity

When a hypothesis of the correct answer is inferred as negative authenticity, a different learning process is used while the hypothesis has not yet carried out the transfer function interpretation. Including positive authenticity, the hypothesis has positive authenticity, since this state is regarded as the root and backtracking is carried out as described in the previous section (1).

Let us assume, for example, that a correct answer [Γ, γ], as shown in Fig. 5(a), is given. In this case, since the hypotheses have positive authenticity, the states are regarded as root, and backtracking is carried out. As a result, four routes are found, as shown in Fig. 5(c), where identical attributes, [Z, ζ] and [Z, κ] are traced in route 4, because their authenticity differ.

Excluding positive authenticity, in the states preceding execution of the transfer function interpretation, no hypothesis has positive authenticity, backtracking is not carried out, and the input data and the correct answers given are stored. When identical input data are given subsequently, the stored answers are obtained immediately.

For example, let us suppose that a correct answer $[Z, \kappa]$ is given as shown in Fig. 5(a). While, since the hypothesis $[Z, \kappa]$ does not have positive authenticity, backtracking is not carried out, the information, "if the observed fact is $[A, \alpha]$, then the answer is $[Z, \kappa]$ " is stored.

4.3.2 Negative learning

(1) Hypotheses with negative authenticity

When the correct answer given is taken as root, backtracking is carried out by the same process as in the case of positive learning. The route reaching a leaf with the status of either fact or necessity should carry out negative learning, and therefore the weights of each of the relations constituting that route are raised by one rank. Because the hypothesis has negative authenticity, as the weight of relations is raised, the hypothesis is more strongly negated.

For example, let us suppose that a correct answer $[Z, \kappa]$ with negative authenticity is given, and backtracking is carried out. The relations composing these negative learning routes are raised by one rank.

(2) Hypotheses with positive authenticity

A different learning process is used for states preceding the transfer function interpretation, as in the case of positive learning.

Including negative authenticity, the hypothesis with negative authenticity is root, and backtracking is carried out.

Excluding negative authenticity, in the states preceding execution of transfer function interpretation, no hypothesis has negative authenticity, backtracking is not carried out, and the input data and the correct answers given are stored. Thus, when the same input data are given, the stored answers are obtained immediately.

5. A Practical Application

The present system has been applied to one actual case of retrofitting of an existing bridge, Yellow Mill Pond Bridge. The Yellow Mill Pond Bridge, a simple supported girder bridge, was constructed in 1956-1957. It was opened to traffic in January 1958. A large number of fatigue cracks developed at the ends of the cover plates. These cracks resulted from the large volume of truck traffic and the unanticipated low fatigue resistance of the large-sized cover-plated beam members. One of the main girders whose crack extended into the web was removed, and all three damaged girders were repaired with bolted web and flange splices, while minute cracks and small cracks were repaired with peening and gas tungsten arc melting, respectively.

The present expert system was executed using the observed fact. The input data given as the cause of cracking is "live load" and "stress concentration", joint action is twelve number, and cracking mode is (i). Figure 6 gives the inference result. Seven necessity hypotheses were obtained with regard to the retrofitting method, while the methods actually adopted were only five. Of these seven solutions, only "high tension bolt" and "splice plate" coincide with the methods actually adopted, the other three adopted methods being obtained as only negative hypotheses of low possibility. These inference results are due to the fact that neither corresponding nor identical knowledge is included in the knowledge base.

In such a case, the system must be made to learn by teaching the actual results. First, the system is given correct answer, i.e., that the retrofitting methods are "peening", "remelting", and "replacement of main girder", and the system executes positive learning. Furthermore, because of the seven retrofitting methods previously inferred by the system, "moment plate" is undesirable, and the system also executes negative learning. The learning result is shown in Fig. 7: the required solutions are obtained by positive learning, while undesirable ones are negated by negative learning. It is able to confirm that the network is reconstructed better by the proposed learning system.



| Status | Authenticity | Attribute | Attribute value |
|-----------------|--------------|-----------|--------------------------------------------|
| Fact | Positive | Cause | Live load |
| | Positive | Cause | Stress concentration |
| | Positive | Force | Joint 12 |
| | Positive | Cracking | i |
| Necessity | Positive | Method | Stop hole |
| | Positive | Method | Gouging |
| | Positive | Method | Grinding |
| | Positive | Method | Rewelding |
| | Positive | Method | High tension bolt |
| | Positive | Method | Splice plate |
| | Positive | Method | Moment plate (main girder-floor beam) ← |
| | Positive | Cause | Secondary stress concentration |
| Possibility | Positive | Method | Lengthening web gaps |
| | Positive | Method | Lengthening web gaps |
| Low possibility | Negative | Method | Peening ← |
| | Negative | Method | Remelting ← |
| | Negative | Method | Replacement of main girder ← |

Fig. 6. First Inference Result for Yellow Mill Pond Bridge

| Status | Authenticity | Attribute | Attribute value |
|-----------------|--------------|-----------|--------------------------------------------|
| Fact | Positive | Cause | Live load |
| | Positive | Cause | Stress concentration |
| | Positive | Force | Joint 12 |
| | Positive | Cracking | i |
| Necessity | Positive | Method | Stop hole |
| | Positive | Method | Gouging |
| | Positive | Method | Grinding |
| | Positive | Method | Peening ← |
| | Positive | Method | Rewelding |
| | Positive | Method | Remelting ← |
| | Positive | Method | High tension bolt |
| | Positive | Method | Splice plate |
| | Positive | Method | Replacement of main girder ← |
| | Negative | Method | Moment plate (main girder-floor beam) ← |
| Possibility | Positive | Method | Lengthening web gaps |
| | Positive | Method | Lengthening web gaps |
| Low possibility | Negative | Method | Extending thickness |
| | Negative | Method | Extending thickness |

Fig. 7. Inference Result after Learning for Yellow Mill Pond Bridge

6. Conclusions

In this study, we have enlarged the knowledge-base and improved the inference and learning capabilities of our expert system for selecting retrofitting methods in cases of steel bridge fatigue damage, as previously reported by Mikami et al.(1994).

First, to complete the knowledge-base, causal relations were weighted according to the year when each relevant case of fatigue damage was detected, and the number of cases detected. Causal relations of unknown existence were defined as relations with negated conclusion, while those impossible of definition by causal relation alone were newly expressed using included relations. Analogical inference was made possible by generating new relations from included relations. Not only positive learning, by which the inference results are brought closer to correct answers, but also negative learning, by which undesirable results are removed, were made possible. The improved system is far more capable of deriving probable solutions from observed facts. Frequent usage of its positive and negative learning ability will further refine the knowledge.

References

- Doyle, J.(1979). "A truth maintenance system." *Artificial Intelligence*, 12(13), 231-272.
- Fisher, J. W.(1984). *Fatigue and fracture in steel bridges*. John Wiley and Sons, Inc., New York, N.Y.
- Michalski, R. S., Garbonell, J. G., and Mitchell, T. M.(1983). *Machine learning: an artificial intelligence approach*. Vol.I, Tioga Publishing Co., Calif.
- Mikami, I., Miki, C., Tanaka, S., and Tsuchida, T.(1990). "Causal network inference procedure for reasonable method of retrofitting fatigue cracked members in steel bridges." *Proc., Korea-Japan Joint Seminar on Steel Bridges*, Korean Soc., of Steel Constr., Seoul, Korea, 231-240.
- Mikami, I., Miki, C., Tanaka, S., and Tsuchida, T.(1991). "Causal network inference procedure for selecting repair method of fatigue damage in steel bridges." *Proc., 3rd East Asia-Pacific Conf. on Structural Engineering and Construction*, EASEC, Shanghai, China, 1005-1010.
- Mikami, I., Tanaka, S., and Kurachi, A.(1994). "Expert system with learning ability for retrofitting steel bridges." *Journal of Computing in Civil Engineering*, ASCE, 8(1), 88-102.