

Dynamic response of building with isolation on rubber cushions

Autor(en): **Petrovski, Jakim / Jurukovski, Dimitar / Simovski, Vladimir**

Objekttyp: **Article**

Zeitschrift: **IABSE reports of the working commissions = Rapports des commissions de travail AIPC = IVBH Berichte der Arbeitskommissionen**

Band (Jahr): **30 (1978)**

PDF erstellt am: **23.09.2024**

Persistenter Link: <https://doi.org/10.5169/seals-24167>

Nutzungsbedingungen

Die ETH-Bibliothek ist Anbieterin der digitalisierten Zeitschriften. Sie besitzt keine Urheberrechte an den Inhalten der Zeitschriften. Die Rechte liegen in der Regel bei den Herausgebern.

Die auf der Plattform e-periodica veröffentlichten Dokumente stehen für nicht-kommerzielle Zwecke in Lehre und Forschung sowie für die private Nutzung frei zur Verfügung. Einzelne Dateien oder Ausdrucke aus diesem Angebot können zusammen mit diesen Nutzungsbedingungen und den korrekten Herkunftsbezeichnungen weitergegeben werden.

Das Veröffentlichen von Bildern in Print- und Online-Publikationen ist nur mit vorheriger Genehmigung der Rechteinhaber erlaubt. Die systematische Speicherung von Teilen des elektronischen Angebots auf anderen Servern bedarf ebenfalls des schriftlichen Einverständnisses der Rechteinhaber.

Haftungsausschluss

Alle Angaben erfolgen ohne Gewähr für Vollständigkeit oder Richtigkeit. Es wird keine Haftung übernommen für Schäden durch die Verwendung von Informationen aus diesem Online-Angebot oder durch das Fehlen von Informationen. Dies gilt auch für Inhalte Dritter, die über dieses Angebot zugänglich sind.

DYNAMIC RESPONSE OF BUILDING WITH
ISOLATION ON RUBBER CUSHIONS

by

Jakim PETROVSKI, Professor and Director
Dimitar JURUKOVSKI, Associate Professor

Institute of Earthquake Engineering and
Engineering Seismology, University of
Skopje, Yugoslavia

Vladimir SIMOVSKI, Assistant Professor
Civil Engineering Faculty,
University of Skopje, Yugoslavia

SUMMARY

Dynamic response of the three-story reinforced concrete school building with foundation isolation constructed in Skopje is presented and discussed. The idea of foundation isolation has been achieved by applying rubber cushions between the strip foundation and the ground floor slab of the super-structure.

Full-scale studies were carried out in order to determine dynamic properties of the building, and the response of the building with foundation isolation effect is analysed.

1. INTRODUCTION

Foundation isolation is one of the oldest attempts to isolate the structures from the influence of the ground earthquake motions. In the past few years new ideas in modern construction have been theoretically and experimentally investigated and developed by engineers and scientists (4,6), for practical application.

The results presented in this paper concern the dynamic response of three-story reinforced concrete school building, constructed in Skopje in 1969. The building was designed and developed by Swiss engineers (6). The main idea of foundation isolation has been achieved by applying rubber cushions between the strip foundation and the first floor slab of the super-structure. The building is constructed as reinforced concrete walled structure in both orthogonal directions.

Ambient vibration tests were carried out in order to determine dynamic properties of the building. Simple cantilever beam model with interactive stiffness parameters has been used to model building-foundation system. Using experimental results the formulation of the mathematical model has been performed. A good correlation between the experimental and analytical results for both resonance frequencies and the mode shapes have been obtained and typical results are presented.

2. DESCRIPTION OF THE BUILDING

The building of the classroom wing of the "H. Pestalozzi" school is designed and built as monolithic walled structure with base isolation applying rubber cushion elements over the strip foundation. The "H. Pestalozzi" school was designed by Swiss engineers (6) and built with the funds provided by the Swiss people and authorities in organization of the Swiss Group of the Inter-parliamentary Union, as a contribution in the gigantic programme of rehabilitation and reconstruction of Skopje after the catastrophic earthquake of July 26, 1963.

The super structure of the classroom wing is monolithic three story reinforced concrete walled structure with thickness of the walls of 20-33 cm, and 20 cm depth of the monolithic reinforced concrete floor slabs. Typical floor plan and cross section of the wing are shown in Figs 1 and 2.

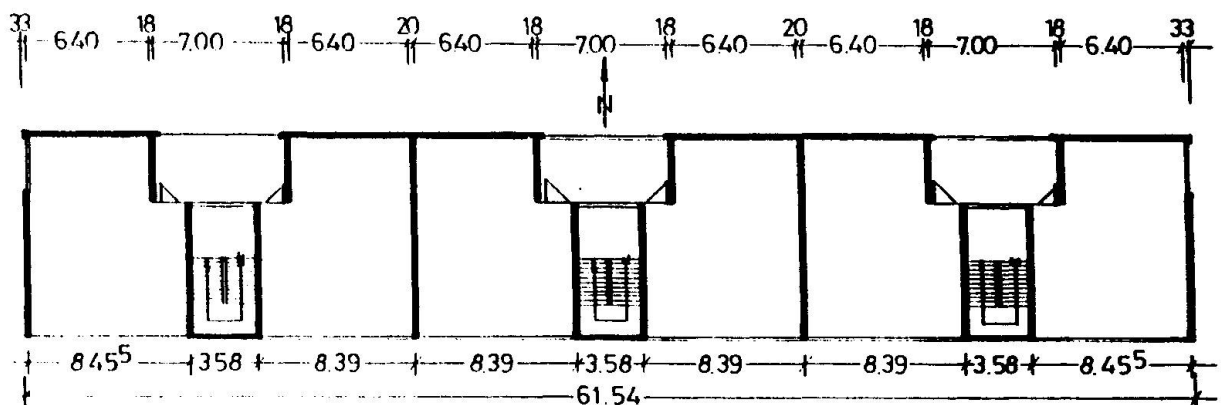

Fig. 1 Plan of a typical floor of the building

The strip reinforced concrete foundation is placed in a dense gravel, and special housing for the rubber cushion elements was provided within strip foundations. The total number of the rubber cushion elements in which the supper structure of the building is placed is 54 (Fig. 3).

These elements are designed, developed and tested (6) in cooperation of the designers of the building, engineers of Swiss rubber factory and the E.M.P.A (Swiss Federal Research and Testing Laboratories for Buildings Materials). The dimensions of each rubber cushion are 70/70/35 cm. made of the vulcanized India rubber in order to achieve maximal isolation effect for the frequency range of 5 to 30 cps with high damping effects.

Fig. 3 (a),(b),(c). The supper structure was built on a reinforce concrete gride and continuous slab at the ground floor. After completion of the supper structure rubber elements were inserted in their position and fixed. Then each of the rubber elements was put under prestabilized pressure lifting their bearing beam to the determined level. With two groups of hydraulic presses in the corresponding sequence the rubber elements were put under stress constituting them as bearing supports of the supper structure.

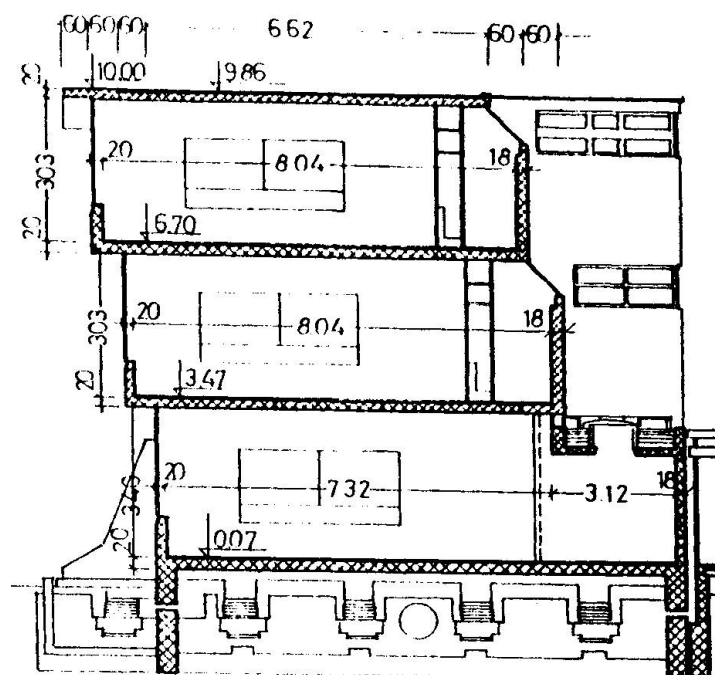

Fig. 2 Cross-section of the building

3. AMBIENT VIBRATION TESTS

The objective of performing the ambient vibration study was to obtain dynamic properties of the building and then to compare them with those obtained from the analyses of the mathematical model response. The ambient vibration method of testing full-scale structures is based on wind and microtremor-induced vibrations. It is a fast and relatively simple method of field measurements without interference in the normal building function. Although this method of dynamic testing of full-scale structures is based on small levels of excitation, compared to strong earthquake ground motion, the derived dynamic properties of the structural systems are invaluable since they offer a sound basis for rational improvements of the formulation of the mathematical models in the elastic range of behaviour of the structural systems (5,7). In this specific case of the classroom building of the school in Skopje, the response of the building is practically controlled by the rubber cushion elements, thus the application of this method is quite efficient.

The microtremor-induced vibrations were measured using Kinematics Ranger Seismometers, Model SS-1. Single Conditioner, Model SC-1 was used to amplify and control simultaneously four seismometer signals. The amplified analogue signals were recorded on a four-channel HP magnetic tape recorder and converted into a digital form using LPS (Lab periferial system) of the PDP 11/45 computer system.

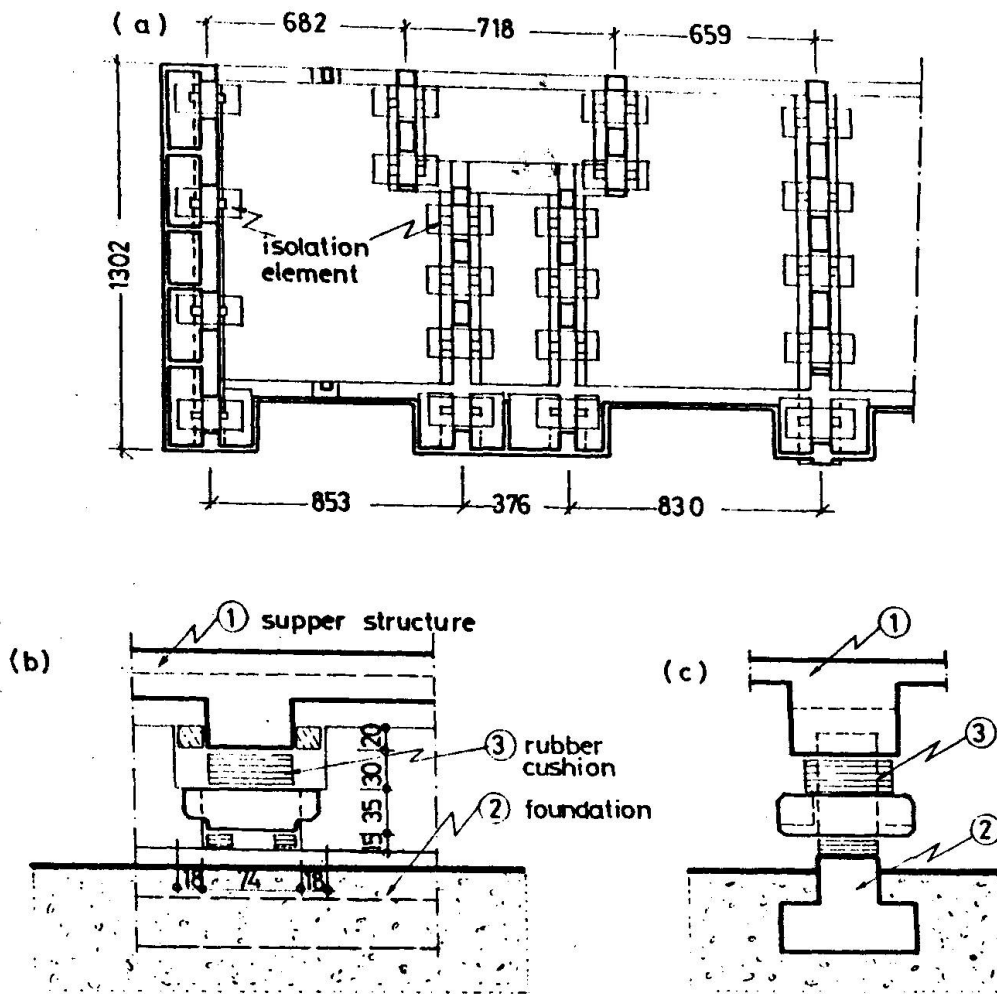

Fig. 3 (a) Partial foundation plan with position of rubber cushions
 (b) Detail of rubber cushions position in the foundation structure
 (c) Cross-section of the foundation with isolation elements

The effective rate of the recorded data from the horizontal vibrations was 60 sec. The signal before recording had passed through a low pass filter set at 40 Hz. Twenty seconds of data from each channel were used in the calculations of the Fourier amplitude spectra. The standard Fourier amplitude spectrum was smoothed by $1/4$, $1/2$, $1/4$ weights.

In the experimental study of building vibration which is based on the linear model, it is assumed that the resulting motions can be expressed as the superposition of models associated with the discrete frequencies. This approach then requires a simultaneous measurement of motion in a given direction for at least two different floors to obtain their relative amplitude and phase, the two quantities required to determine mode shapes. For that reason the first field measurement was a calibration run at the ground floor. All four seismometers were placed at the centre of the ground floor identically oriented. To obtain translational mode frequencies two pairs of seismometers were located at the ground floor centre, oriented in south and west direction, respectively. For this location were carried out several tests. The smoothed Fourier amplitude spectrum for the ground floor is shown in Fig. 4.

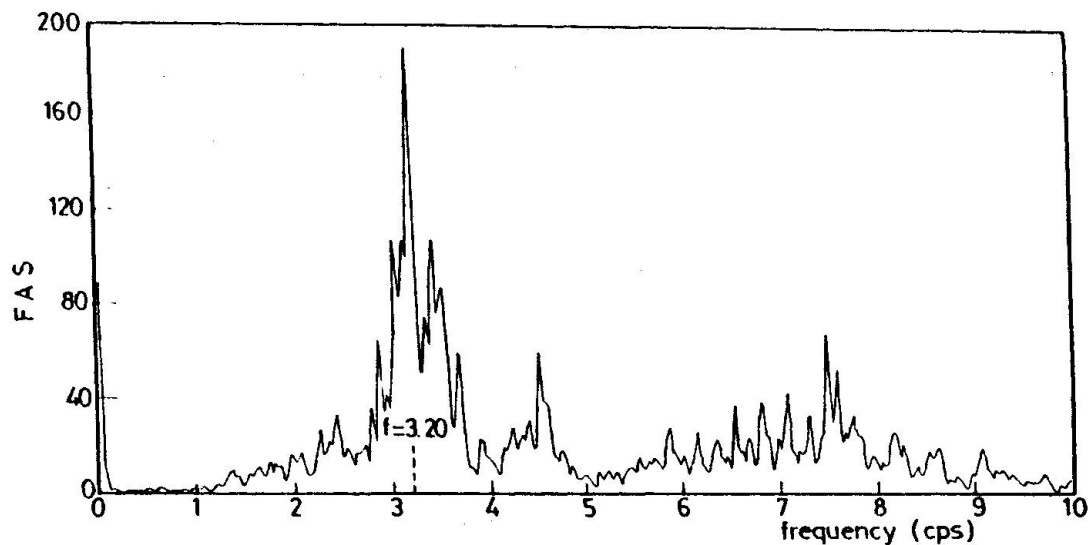

Fig. 4 Fourier amplitude spectra on the ground floor

Similar measurements were carried out at the foundation level of the building under the rubber cushions and the Fourier amplitude spectrum for this level is shown in Fig. 5.

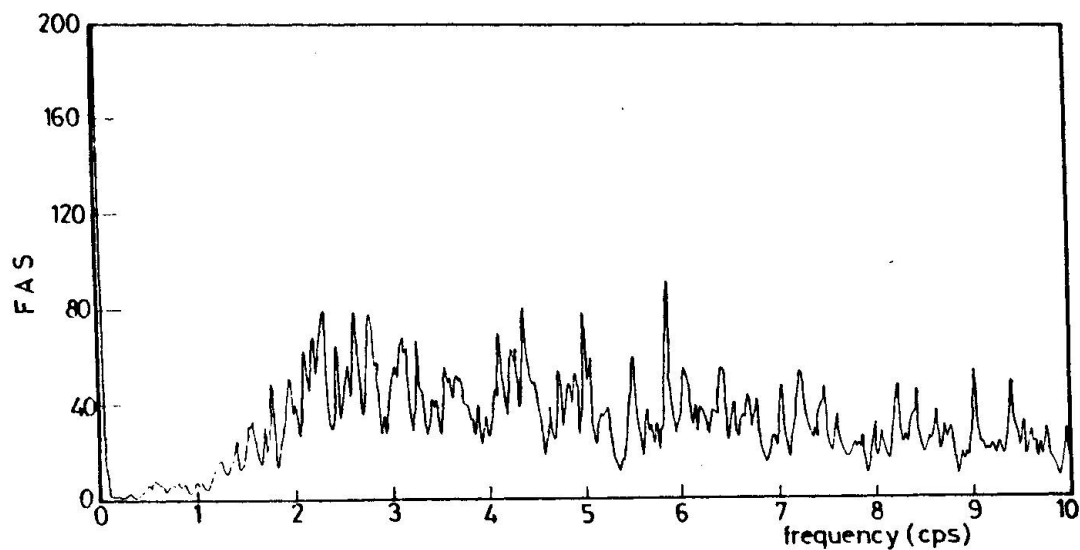

Fig. 5 Fourier amplitude spectra on the foundation under rubber cushion

For measurement of the translational mode shapes two seismometers were placed in the centre of the ground floor and oriented south and west, respectively. The other two seismometers were relocated for each test in the centres of the first and second floor. The measured vertical mode shape is shown on Fig. 6

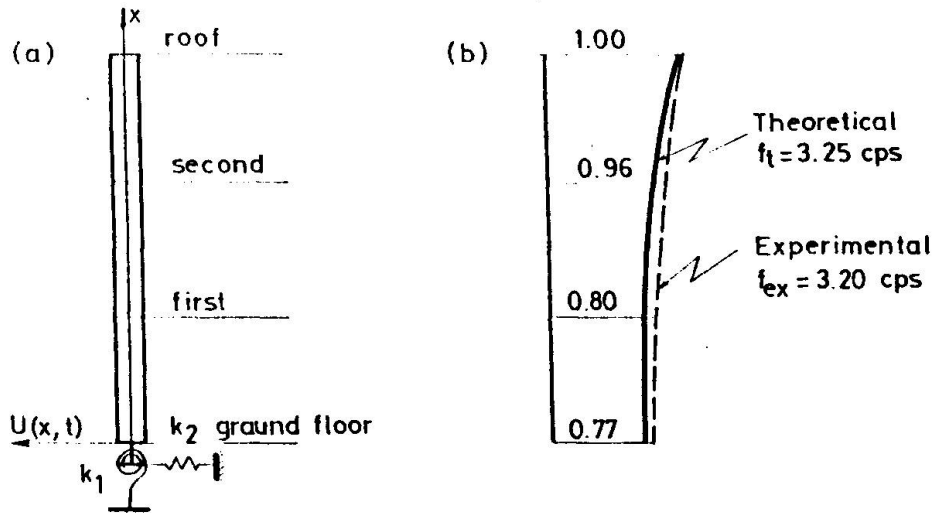

Fig. 6 (a) Cantilever beam model with interactive parameters
 (b) Comparison of the theoretical and experimental mode shape

4. FORMULATION OF THE MATHEMATICAL MODEL

Simple Euler cantilever beam model was chosen to model the behaviour of the building-foundation system. In Fig. 5(a) schematic presentation of the cantilever beam model, with the interactive parameters representing flexibility of the rubber elements is given.

The partial differential equation of the motion for this case of the beam model may be written

$$\frac{\partial^2}{\partial x^2} (EI) \frac{\partial^2 U}{\partial x^2} + \bar{m} \frac{\partial^2 U}{\partial t^2} = 0 \quad \dots (1)$$

This equation neglects the influence of the deformations due to shear forces and the inertial resistance to rotational acceleration of the beam cross section. In equation (1), E is the modulus of elasticity; I is the moment of inertia of the beam; \bar{m} is the mass per unit length of the beam; and L is the length of the beam.

The methods used for solution of this equation is separation of variables which leads to the well known characteristic function:

$$\phi(x) = A_1 \sin ax + A_2 \cos ax + A_3 \sin h ax + A_4 \cos h ax \quad \dots(2)$$

where

$$a = \frac{1}{L} \sqrt{\frac{\omega^2 \bar{m}}{EI}} \quad \dots (3)$$

Four constants A_n in the equation (2) define the shape and amplitude of the beam vibration and they are evaluated by consideration of the boundary conditions at the ends of the beam segment. Substituting the shape-function expression or its derivatives into these boundary conditions leads to the following matrix form:

$$\begin{bmatrix} E I a^3 & -K_1 & -E I a^3 & -K_1 \\ -K_2 & E I a & -K_2 & E I a \\ -\sin(aL) & -\cos(aL) & \sinh(aL) & \cosh(aL) \\ -\cos(aL) & \sin(aL) & \cosh(aL) & \sinh(aL) \end{bmatrix} \begin{Bmatrix} A_1 \\ A_2 \\ A_3 \\ A_4 \end{Bmatrix} = 0 \quad \dots(4)$$

Setting the determinant of the square matrix equal zero provides frequency equation from which a could be obtained. After the modal value of a is obtained from frequency equation it is substituted into the shape-function expression to obtain the corresponding mode shape.

The aim of this analytical presentation is to construct a model of the building in N-S direction that would closely match the dynamic characteristics measured by ambient vibration tests. For this analysis it was assumed that the super structure is very rigid. Values of the interactive parameters k_1 and k_2 were determined from the geometrical and mechanical properties of the rubber cushions. A slight adjustment in the initial value of k_1 was required.

The experimental and theoretical mode shapes for the translational direction (N-S) of the building at the first resonant frequency of 3.20 cps are compared in Fig. 6(b). A comparison of the experimental and analytical results for the resonant frequencies and the mode shapes show very good agreement and approves the consistency of the formulated mathematical model.

5. DISCUSSION OF THE RESULTS

From the Fourier amplitude spectra at the foundation level under the rubber cushion (Fig. 5) it could be seen that the spectra is of about the same amplitude content for the wide frequency range. The Fourier amplitude spectra at the ground floor (Fig. 4) for the same conditions of microtremor-induced vibrations shows dominant peaks at frequencies 3.20, 4.50 and 7.50 cps. It is evident that at these frequencies are possible resonances of the considered building. The shape difference between two amplitude spectra at the ground floor and foundation level is evident, and it could be concluded that the vibration amplitudes for the frequencies larger than 3.20 cps are significantly damped.

In order to predict the dynamic properties of the building a simple mathematical model was formulated. The super structure is taken as relatively rigid with dominant bending deformations.

Most important part in the mathematical model formulation is determination of the interactive parameters. Experimental results are showing that for this system the dominant effect is of the horizontal deformations of the rubber cushions. Based on the mode shape evaluation for the resonant frequency at 3.25 cps the translational spring (k_2) controls about 80% of the total amplitude of vibration. The rest 20% of the amplitude of vibration are controlled by the rotational stiffness of the rubber cushions and the super structure flexibility.

6. CONCLUSIONS

The dynamic properties of the building with base isolation on rubber elements as obtained from ambient vibration tests and as predicted from analytical model are in good correlation. The effectiveness of base isolation is evident in the wide range of frequencies before and after 3.20 cps. More detailed investigations of

the building are needed by performing forced-vibration tests for several different levels of excitation. The building is instrumented with four strong-motion accelerographs, two at the foundation level under rubber cushions and two at the ground floor level, respectively. Expected strong-motion records will give data for final verification of the isolation effect of the system.

REFERENCES

1. Bouwkamp, J.G. and Rea, D., "Dynamic Testing and Formulation of Mathematical Models", Chapter VIII in Earthquake Engineering, editor Wiegel, R. L., Prentice Hall, 1970.
2. Clough, R.W. and Penzien, J., Dynamics of Structures, Mc Graw Hill, 1975
3. Cooley, J.W. and Tukey, J.W., "An Algorithm for the machine calculation of complex Fourier series", Math. of Comp. 19, p. 297-301 (1965)
4. Derham, C.J., at all "Natural rubber foundation bearings for earthquake protection - experimental results", NR Technology, Vol. 8, Part 3, 1977
5. Petrovski, J., Stephen, R.M., Gartenbaum, E. and Bouwkamp, J.G., "Dynamic Behaviour of a Multistory Triangular-shaped Building", Rep. No. EERC 76-3, University of California, Berkeley, 1976
6. Roth, A., Hubacher, C., Staudacher, E., Sigenthaler, R., Haldimann, W. and Held, F., "Erdbebensicherung im Banen - Das Schulhaus Heinrich Pestalozzi in Skopje, Jugoslavien", Separatbruch ans der Neken Zurcher Zectung, Beilage Twchnik, vom. 9, Februar 1970
7. Trifunac, M.D., "Comparisons Between Ambient and Forced Vibration Experiments" Earthquake Engineering and Structural Dynamics, 1, 1972, p. 133-150.