

The new stadium for football and track events, Bari (Italy)

Autor(en): **Vitone, V.**

Objekttyp: **Article**

Zeitschrift: **IABSE structures = Constructions AIPC = IVBH Bauwerke**

Band (Jahr): **14 (1990)**

Heft C-52: **Football stadiums in Italy**

PDF erstellt am: **26.09.2024**

Persistenter Link: <https://doi.org/10.5169/seals-22198>

Nutzungsbedingungen

Die ETH-Bibliothek ist Anbieterin der digitalisierten Zeitschriften. Sie besitzt keine Urheberrechte an den Inhalten der Zeitschriften. Die Rechte liegen in der Regel bei den Herausgebern.

Die auf der Plattform e-periodica veröffentlichten Dokumente stehen für nicht-kommerzielle Zwecke in Lehre und Forschung sowie für die private Nutzung frei zur Verfügung. Einzelne Dateien oder Ausdrucke aus diesem Angebot können zusammen mit diesen Nutzungsbedingungen und den korrekten Herkunftsbezeichnungen weitergegeben werden.

Das Veröffentlichen von Bildern in Print- und Online-Publikationen ist nur mit vorheriger Genehmigung der Rechteinhaber erlaubt. Die systematische Speicherung von Teilen des elektronischen Angebots auf anderen Servern bedarf ebenfalls des schriftlichen Einverständnisses der Rechteinhaber.

Haftungsausschluss

Alle Angaben erfolgen ohne Gewähr für Vollständigkeit oder Richtigkeit. Es wird keine Haftung übernommen für Schäden durch die Verwendung von Informationen aus diesem Online-Angebot oder durch das Fehlen von Informationen. Dies gilt auch für Inhalte Dritter, die über dieses Angebot zugänglich sind.



1. The New Stadium for Football and Track Events, Bari (Italy)

Owner: *Municipal Administration of Bari*
Architect: *Renzo Piano/Building Workshop-Genova*
Engineers: *Vitone & Associati – Bari*
Michetti – Roma
REICO – Milano
Ove Arup & Partners – London
(steel structure)
Contractor: *Consorzio «Stadium» – Bari*
Works duration: *24 months*
Service date: *March 1990*

The stadium for football and track in Bari is a completely new structure built for the 1990 Football World Championship.

This stadium, which is situated in the south-west of the town, can accommodate about 60 000 spectators each one having a numbered seat. Stands for people (23 500 m² the lower, 18 000 m² the upper stand) are arranged in two rings placed one upon the other and both built in reinforced concrete. The bleachers, which have a longitudinal alignment over a length of 31 m are completely precast. The lower ring is between level 0 and level + 6.50 m; inside there is a road, suitable for police and first aid cars and for facilities and utilities; an artificial embankment, 60 000 m² large (1 m²/spectator), has been placed to the external wall. In the upper ring



Fig. 2: Internal view

there are 26 sectors divided by the entry stairs. Each sector is supported by 4 pillars (sect. 1.10 m × 1.80 m); the outside pillars are 11.50 m high, the interior ones are 5.50 m. On the upper ring top there is the cantilevered steel covering structure, which is continuous on the whole ring perimeter and is sheeted with a prestressed PTFE (Poly Tetra Fluoro Ethilene) fiber glass membrane (covered surface about 15 000 m²).

The stadium structure has been designed to take seismic stresses of medium intensity (grade S=9, seismic protection coefficient I=1.2 of Italian Standard Codes).

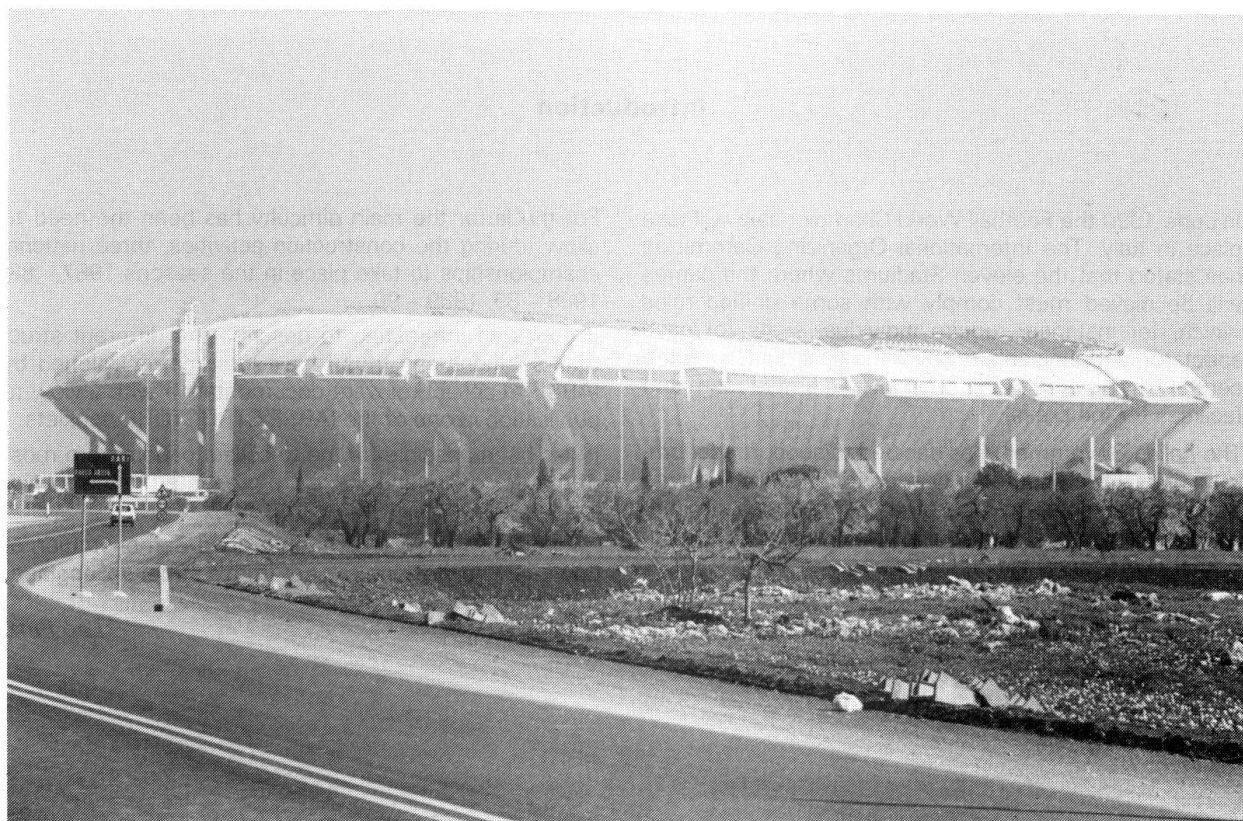

Fig. 1: External view: the upper stand and the hill

The geometrical shape of the structure is very complicated for many different reasons. First of all, its alignment is always curved; then the intrados surface of the upper ring is formed by double curving «staves», inscribed in a toric polycentric surface; then the levels of the external edge of this ring change continuously (from + 30 m on the east-west axis to + 25.7 m on the north-south axis); besides the covering steel structure has a great variability both in dimension and in form. These aesthetic choices have required the use of a lot of structural elements of different shape and size, precast and cast-in-situ.

The design of the reinforced concrete structure had to conciliate the architectural idea of the «suspensions» of the upper ring from thin pillars with the necessity of providing the structure with the right strength and stiffness, also concerning the seismic stresses.

The lower ring has large annular walls and 26 ballasting blocks (3000 KN weight) able to stand the considerable horizontal stresses both radial and annular.

Expansion joints divide in pairs each of the upper ring's 26 sectors; this structure is made of 10 radial and 4 annular beams. The annular beams were completely cast-in-situ; regarding the radial girders (inverse T-beam section), their bottom part was precast, which includes the fair faced flange, stove-shaped, while the upper part of the rib was cast-in-situ.

The grid structure so formed, restrained to the 4 underlying pillars, has been divided into two parts: the more complex geometrical parts (situated at the shell intrados), which are mostly compressed, have been precast; all the other parts, traction stressed, and those ones playing a decisive role in the general behaviour of the structure, were constructed completely in situ without a halt.

During the stands' construction period, a specialized laboratory was provided to check the stresses, strains and settlements of their supporting scaffolding.

The two-ringed structures were made in normal reinforced concrete: prestressing was restricted to some connection members.

The main elements of the steel covering structure are composed, in each sector, by 2 cantilevers with box section, connected to the top of the two main radial reinforced concrete girders. Each base plate is locked by 12 steel anchorages M 64/10.9 (see fig. 3, 4) prestressed up to 8000 KN altogether. On the top of the cantilevers an annular reticular girder is located, which comprises an all around facilities footpath. Among these structural elements, mostly made in steel Fe 510 C, tubular arch-shaped structures made in stainless AISI 316 L steel are fitted and suitably wind-braced.

The highest point of the covering structure is located at a level between + 34 and + 43 m; the cantilever span is variable between + 14 and + 26 m.

The stadium foundations, rigid blocks connected with beams and slabs, are placed directly on a calcareous rock substratum. Owing to tectonic fractures and to Karst recesses, induced by underground waters, a preliminary consolidation of the rock layer, with controlled pressure injections of cement mixtures, was necessary.

(V. Vitone)

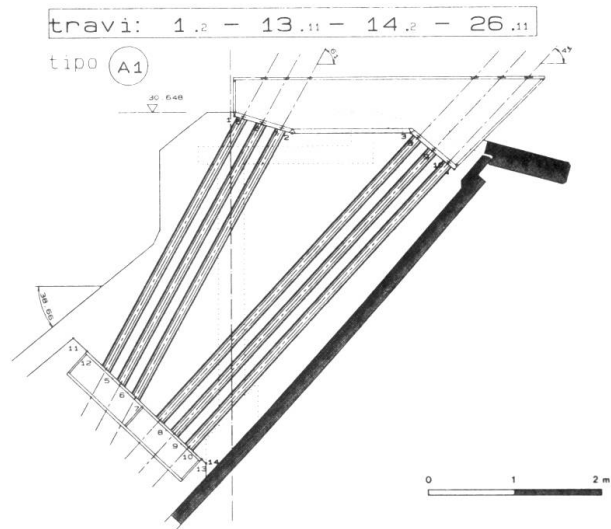

Fig. 3: Scheme of the cantilevers' connection joint

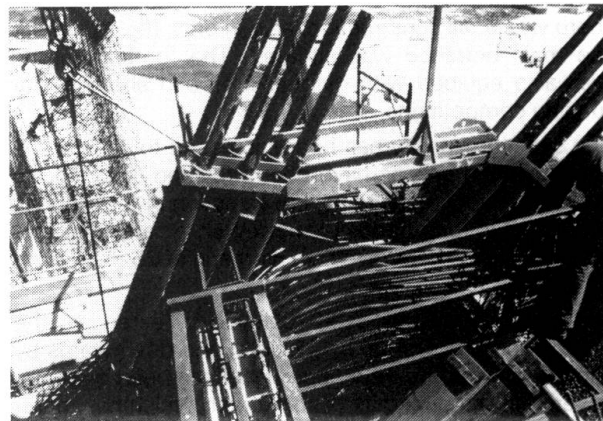

Fig. 4: Cantilevers' connection joint during construction (partial view)

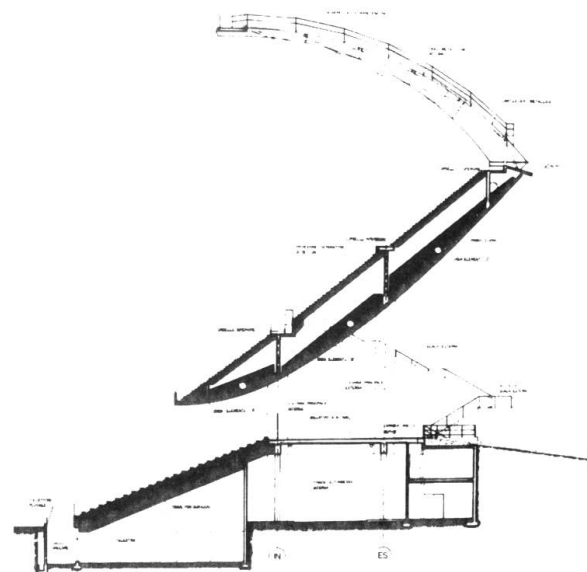

Fig. 5: Stadium's radial section