

New Tjörn Bridge across the Askeröfjord (Sweden)

Autor(en): **Brodin, S.**

Objektyp: **Article**

Zeitschrift: **IABSE structures = Constructions AIPC = IVBH Bauwerke**

Band (Jahr): **6 (1982)**

Heft C-21: **Recent structures**

PDF erstellt am: **21.09.2024**

Persistenter Link: <https://doi.org/10.5169/seals-17587>

Nutzungsbedingungen

Die ETH-Bibliothek ist Anbieterin der digitalisierten Zeitschriften. Sie besitzt keine Urheberrechte an den Inhalten der Zeitschriften. Die Rechte liegen in der Regel bei den Herausgebern.

Die auf der Plattform e-periodica veröffentlichten Dokumente stehen für nicht-kommerzielle Zwecke in Lehre und Forschung sowie für die private Nutzung frei zur Verfügung. Einzelne Dateien oder Ausdrucke aus diesem Angebot können zusammen mit diesen Nutzungsbedingungen und den korrekten Herkunftsbezeichnungen weitergegeben werden.

Das Veröffentlichen von Bildern in Print- und Online-Publikationen ist nur mit vorheriger Genehmigung der Rechteinhaber erlaubt. Die systematische Speicherung von Teilen des elektronischen Angebots auf anderen Servern bedarf ebenfalls des schriftlichen Einverständnisses der Rechteinhaber.

Haftungsausschluss

Alle Angaben erfolgen ohne Gewähr für Vollständigkeit oder Richtigkeit. Es wird keine Haftung übernommen für Schäden durch die Verwendung von Informationen aus diesem Online-Angebot oder durch das Fehlen von Informationen. Dies gilt auch für Inhalte Dritter, die über dieses Angebot zugänglich sind.



8. New Tjörn Bridge across the Askeröfjord (Sweden)

Owner: National Road Administration
Design and construction: Skanska, Stockholm and Gothenburg (general contractor) and Krupp Industrie- und Stahlbau, Rheinhausen, Fed. Rep. of Germany (steelworks)
Works duration: 15 months
Service date: 1981

larger main span and clear headroom. On June 19th 1980, the contract to design and build the bridge was awarded to Skanska with Krupp as subcontractor for the steel works, at a sum of 97 million Swedish crowns.

According to the contract two of the three carriage-way lanes should be opened to traffic not later than December 20th 1981. Actually the opening took place on November 9th, 15 months after the beginning of the work in August the year before.

Design

The bridge has a cable stayed steel main span, concrete towers and concrete approach viaducts. The superstructure is continuous over the whole length of the bridge, the steel and concrete parts being connected near the towers. The superstructure is longitudinally anchored at the abutment of the eastern viaduct, while transverse forces are transmitted to the foundations at the towers and the abutments.

The overall length is 665 m and the clear width 15 m comprising a carriageway of three lanes and a combined footway and cycle track. The deck is surfaced with asphalt. The clear headroom above mean sea level is 45.3 m in the 110 m wide navigation channel.

Introduction

On the night of January 18th 1980, the 278 m long tubular steel arch span of the Tjörn Bridge near Gothenburg was rammed by a cargo ship and completely destroyed. The collapse of the bridge creating serious problems for the islands of Tjörn and Orust, immediate action was taken by the National Road Administration to reconstruct the bridge. Based on design rules and specifications drawn up by the Administration tenders were invited for the design and construction of a new bridge with considerably

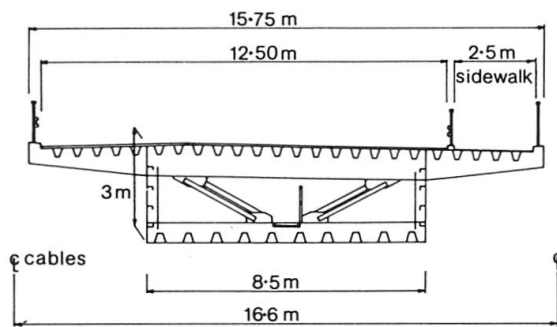

Fig. 1. Cross sections

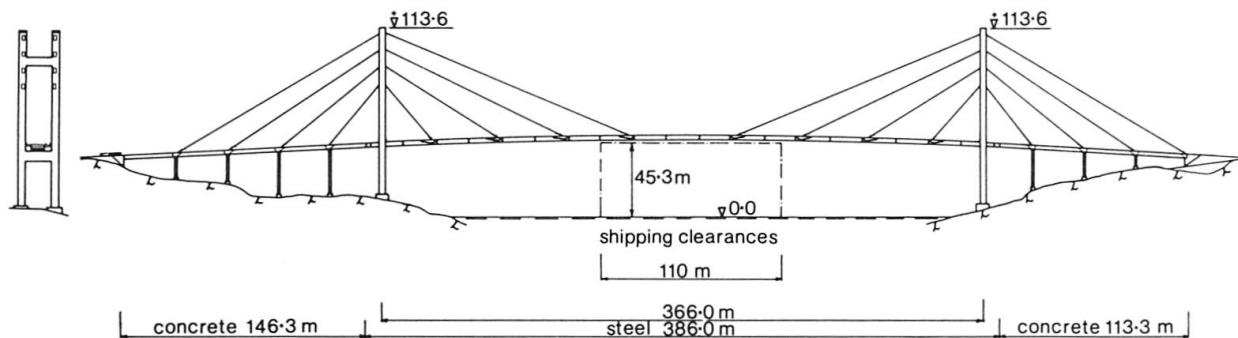
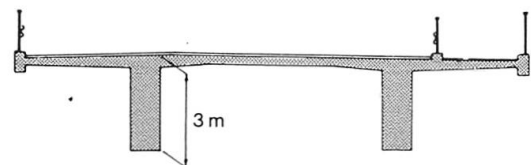

Fig. 2. Tower, Elevation

Towers and viaducts

The towers like all other supports are founded on solid rock. They have two parallel legs of constant section, 4.0 x 4.5 m, connected by cross beams at two levels. The two legs were cast simultaneously by slip-forming in two stages, special measurements being taken to keep down the temperature of the 50 MPa concrete.

Steel anchorages for the cables are attached in recesses at four levels of each tower leg.

The viaducts with spans of 31-32 m, have two cast in situ T-girders of 3 m depth supported by circular concrete pendulum columns. The back stays from the towers are anchored at cross-beams above the columns.

The coupling between viaduct superstructure and main span 10 m from the tower consists of a 3 m long steel segment of the same shape as the main span section. The segment is fastened to the viaduct by dowels and prestressing tendons.

Main span

The main span of 366 m is a welded box girder having a depth of 3 m and cross girders at 4 m centres. The 12 mm deck of the box and its cantilever extensions as well as the bottom plate are stiffened by trapezoidal ribs and the webs by angles. The steel is mainly of the quality OX 524 S, a new Swedish microalloyed structural steel with a yield stress of 355 N/mm².

The span was manufactured in sections of 20 m length at two workshops, Järnmontering in Malmö and Öresundsvarvet in Landskrona, and shipped 300 km to the bridge site on barges.

The erection started at the coupling segments at the towers and proceeded simultaneously from both sides, the 120 t sections being hoisted by derricks and welded to the preceding ones. At every second section stay-cables were installed, the cable forces being transmitted via two reinforced cross girders at each anchorage.

Cables

The stay-cables, located outside the superstructure, consist each of two strands of the locked coil type, diameter 77-108 mm, with hot galvanized 1600 N/mm² wires. The strands are anchored individually to facilitate their replacement.

Dynamic tests

As complement to the wind-tunnel tests carried out in connection with the design, the structural damping of the main span was determined by tests on the erected bridge (sudden release of a static loading). The damping, i.e. logarithmic decrement, for the fundamental bending mode varied from 0.02 at small amplitudes to 0.10 at amplitudes of 15 mm or more.

(S. Brodin)



Fig. 3. The finished bridge