

An experimental and finite element study of the behaviour of folded plate roods containing large openings

Autor(en): **Rockey, K.C. / Evans, H.R.**

Objektyp: **Article**

Zeitschrift: **IABSE publications = Mémoires AIPC = IVBH Abhandlungen**

Band (Jahr): **36 (1976)**

PDF erstellt am: **25.09.2024**

Persistenter Link: <https://doi.org/10.5169/seals-913>

Nutzungsbedingungen

Die ETH-Bibliothek ist Anbieterin der digitalisierten Zeitschriften. Sie besitzt keine Urheberrechte an den Inhalten der Zeitschriften. Die Rechte liegen in der Regel bei den Herausgebern.

Die auf der Plattform e-periodica veröffentlichten Dokumente stehen für nicht-kommerzielle Zwecke in Lehre und Forschung sowie für die private Nutzung frei zur Verfügung. Einzelne Dateien oder Ausdrucke aus diesem Angebot können zusammen mit diesen Nutzungsbedingungen und den korrekten Herkunftsbezeichnungen weitergegeben werden.

Das Veröffentlichen von Bildern in Print- und Online-Publikationen ist nur mit vorheriger Genehmigung der Rechteinhaber erlaubt. Die systematische Speicherung von Teilen des elektronischen Angebots auf anderen Servern bedarf ebenfalls des schriftlichen Einverständnisses der Rechteinhaber.

Haftungsausschluss

Alle Angaben erfolgen ohne Gewähr für Vollständigkeit oder Richtigkeit. Es wird keine Haftung übernommen für Schäden durch die Verwendung von Informationen aus diesem Online-Angebot oder durch das Fehlen von Informationen. Dies gilt auch für Inhalte Dritter, die über dieses Angebot zugänglich sind.

An Experimental and Finite Element Study of the Behaviour of Folded Plate Roofs containing large Openings

Une étude expérimentale et par éléments finis sur le comportement de structures plissées, avec des grandes ouvertures

Eine experimentelle und mit finiten Elementen durchgeführte Studie über das Verhalten von Faltwerken mit grossen Öffnungen

K. C. ROCKEY

Professor of Civil and Structural Engineering,
University College, Cardiff.

H. R. EVANS

Senior Lecturer in Civil and Structural
Engineering, University College, Cardiff.

1. Introduction

Folded plate structures provide an economical and aesthetically pleasing solution to the problem of roofing large areas. Because of the increasing popularity of folded plates, many methods have been proposed for their analysis, and these methods were critically reviewed by the authors in a previous publication¹, where it was shown that most of the methods are extremely limited in their field of application.

In the first place, the methods assume the structure to be supported at its ends only, so that they are unable to deal with the analysis of folded plates having intermediate column supports. Then, secondly, they assume each component plate of the structure to be homogeneous and of uniform thickness throughout, so that they cannot be applied to the analysis of folded plates containing openings. Now, since folded plates are mainly used for roofing, intermediate column supports are frequently employed around the perimeter to improve the structural performance of the folded plate structure, since the presence of these external supports does not interfere significantly with the efficient use of the covered area. In addition, the provision of large glazed openings to allow for natural lighting is frequently essential. Thus, a more generally applicable method of analysis is clearly needed.

In a previous publication, EVANS² discussed the application of the finite element method to the analysis of folded plates supported by intermediate columns, and an experimental investigation was carried out which established the accuracy of such an approach. In this present report, the finite element technique will be extended to deal with folded plates containing large openings, and, once again, the results of an experimental investigation will be presented so that the accuracy of the proposed method can be assessed and also so that the effect of the openings on the overall structural behaviour can be observed.

2. Details of Models Tested

The folded plate models tested were of a vault-type cross-section having the dimensions shown in Figure 1, the longitudinal span between end supports being 1810 mm. The models were formed from aluminium sheet having a thickness of 2 mm, a modulus of elasticity of $70.33 \times 10^6 \text{ N/mm}^2$ and a Poisson's ratio of 0.32. Since the models were folded from a single flat sheet, full continuity between adjacent plates at each longitudinal ridge was ensured.

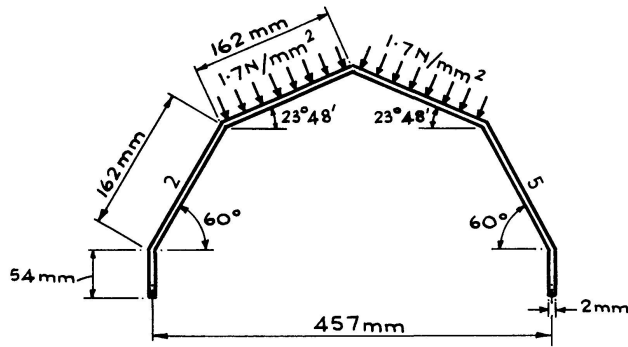

Fig. 1. Details of Vault Type Model Cross-section considered in the Experiments.

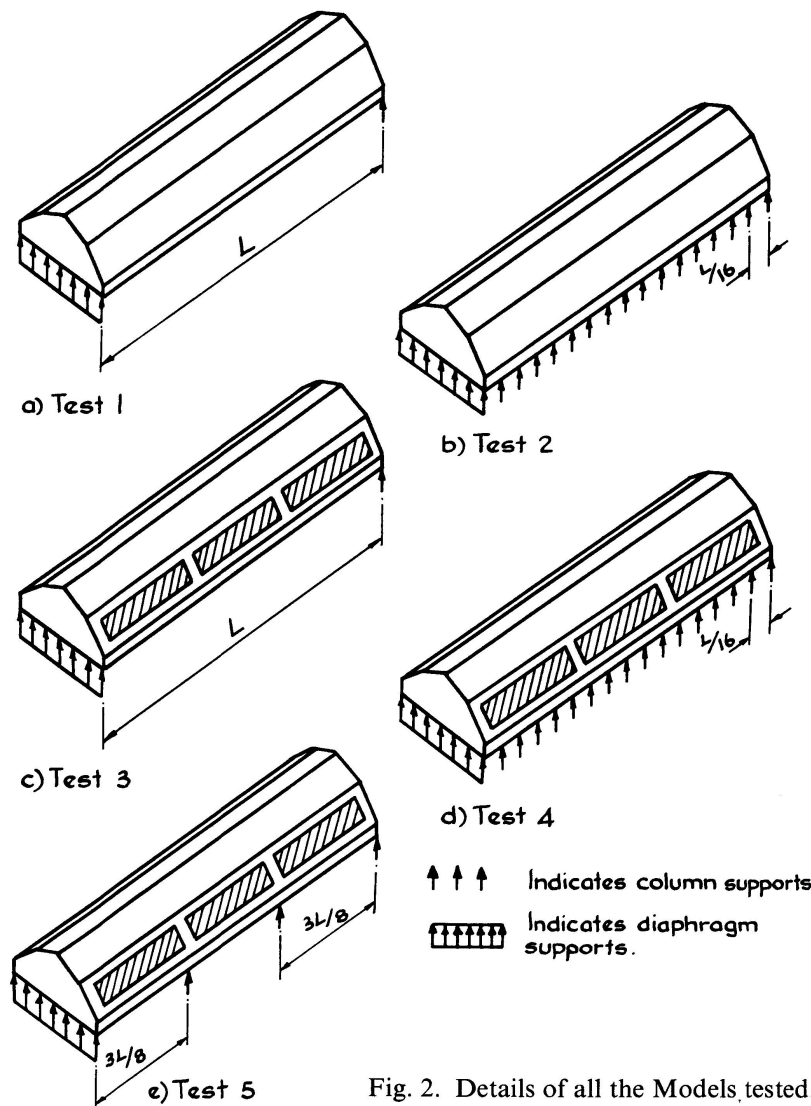

Fig. 2. Details of all the Models tested.

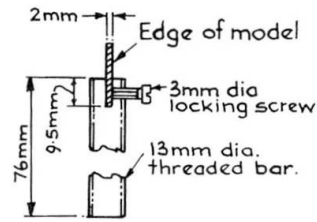

Fig. 3. Details of Column Supports.

The first two models tested did not contain openings and were subjected to differing support conditions at their longitudinal edges, see Figure 2. In the first test, the model had a clear span between end diaphragms, as shown in Figure 2(a), whereas, in the second test, column supports were introduced at intervals equal to one-sixteenth of the span underneath the longitudinal edges, as shown in Figure 2(b). These column supports were designed such that they restrained all the displacements at their points of application. A full description of these columns has been given in Reference 2, which reported on the effect of various column support conditions. A typical column is illustrated diagrammatically in Figure 3, and then, in Figure 4, three of the columns are shown in position during an actual test.

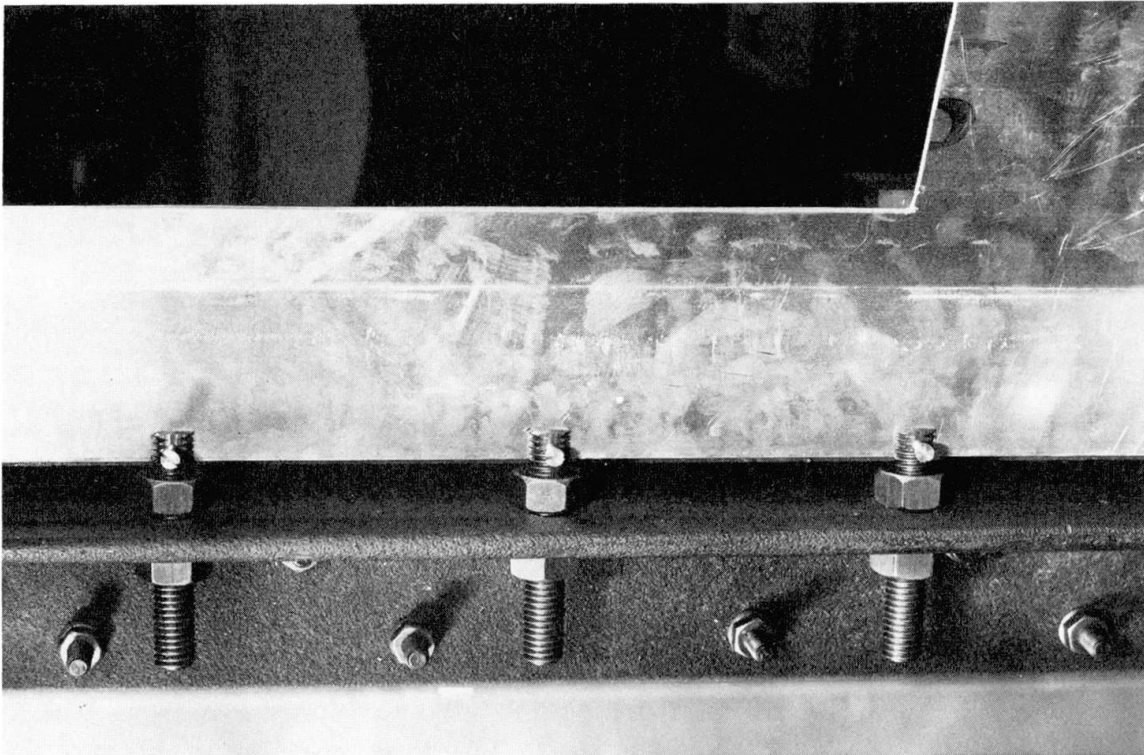

Fig. 4. Edge supporting Columns shown in position during a Test.

Following the test on the structure shown in Figure 2(b), three large window openings were cut in each of the two outer sloping plates of the model, i.e. plates 2 and 5, as defined in Figure 1. The dimensions of these openings relative to those of the complete plate are shown in Figures 5 and 6, and it is seen that the openings were substantial and that they accounted for some 68% of the area of the complete plate.

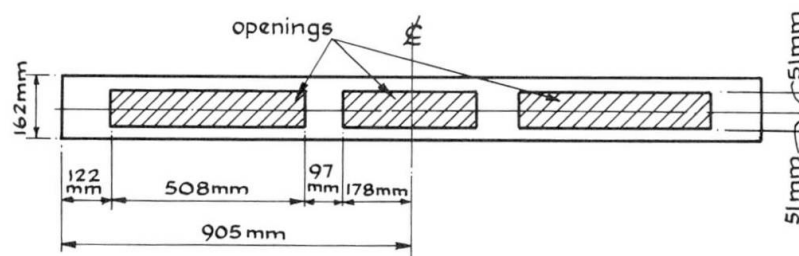

Fig. 5. Dimensions of Window openings introduced in the Model for Tests 3, 4 and 5.

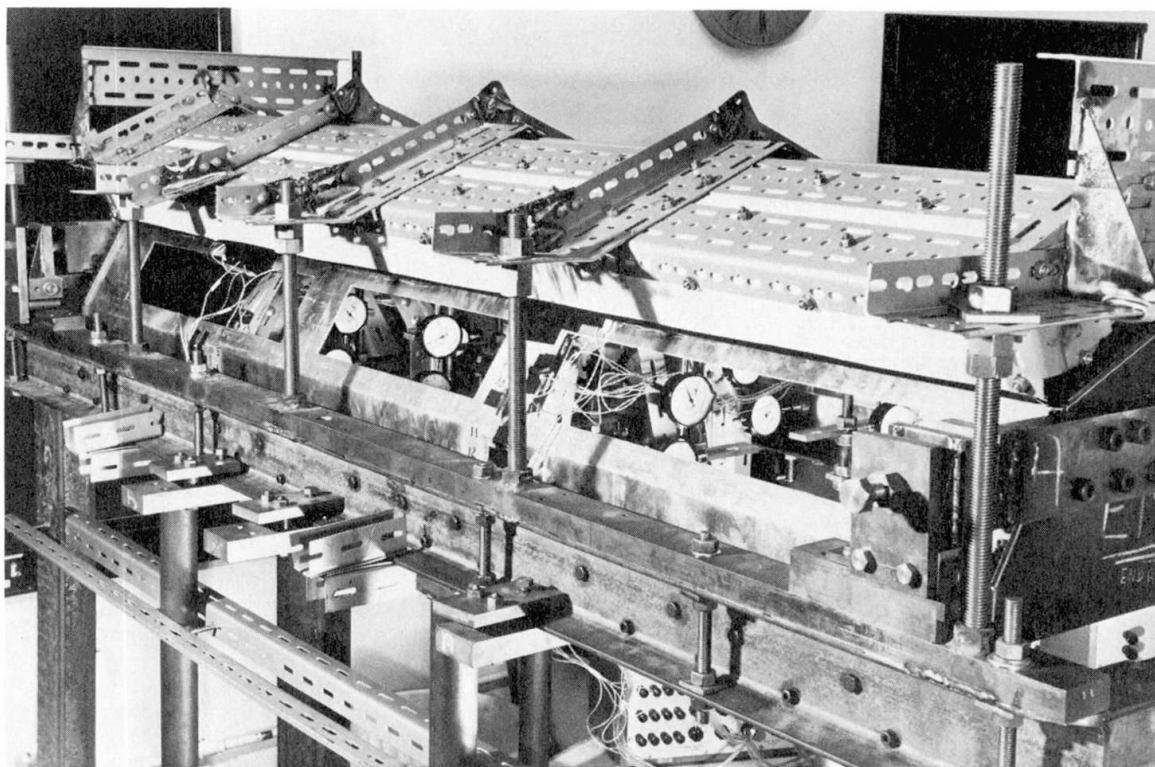

Fig. 6. General View of Model containing Openings under Test.

Three tests were carried out on the model containing openings. The model was first tested with its longitudinal edges completely free, as shown in Figure 2(c), then with the columns reintroduced at the one-sixteenth span positions, as in Figure 2(d), and, finally, with only two columns introduced under each edge, as shown in Figure 2(e), each of the two columns being positioned at a distance equal to $\frac{3}{8}$ of the span away from the end supports. From Figure 2(e), it is apparent that the column support positions in this final test coincided with the centre of the remaining solid portions of the outer sloping plates.

Five tests were thus carried out in all, and these have been summarized in Table 1.

Table 1

TEST 1	(Figure 2 (a))	— Model without openings and with clear span between end supports.
TEST 2	(Figure 2 (b))	— Model without openings and with columns introduced at one-sixteenth span positions.
TEST 3	(Figure 2 (c))	— Model with openings and with clear span between end supports.
TEST 4	(Figure 2 (d))	— Model with openings and with columns introduced at one-sixteenth span positions.
TEST 5	(Figure 2 (e))	— Model with openings and with columns introduced at distance of $\frac{3}{8}$ -span from each end support.

3. General Experimental Details

In all of the tests, symmetrical loads of uniform intensity were applied by means of a pressure bag system, perpendicular to the two top plates of the model, as shown in Figure 1. The models were all supported by end diaphragms which were designed so that free rotation and translation perpendicular to their planes was allowed, see Figures 6 and 7. In addition, the diaphragms were sufficiently rigid so that it could be assumed that all movements within the planes of the diaphragms were restricted.

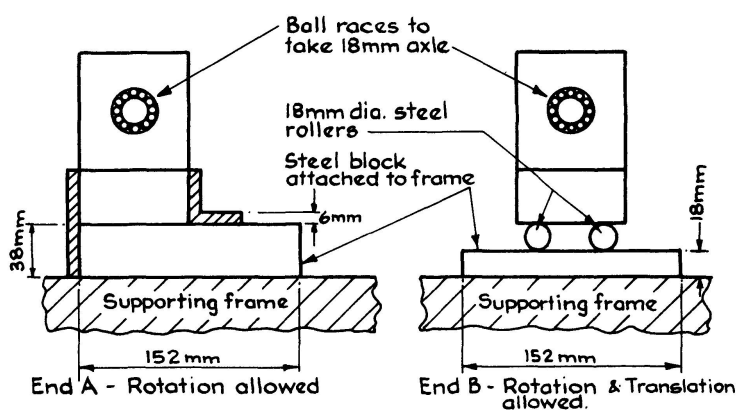

Fig. 7. Side View of End Support Assemblies.

During all of the tests, the ridge displacements of the models were measured at the mid-, $\frac{3}{8}$ - and $\frac{1}{4}$ -span cross-sections, as shown in Figure 8(a). The displacements perpendicular to the planes of the plates were measured at the $\frac{1}{4}$ -span cross-section in Tests 1 and 2 and at the $\frac{3}{8}$ -span cross-section in Tests 3, 4 and 5, see Figure 8(b). The $\frac{3}{8}$ -span cross-section coincided with the section mid-way between the window openings in these latter tests. All displacements were recorded by means of dial gauges graduated in units of 0.0025 mm, positioned underneath the model.

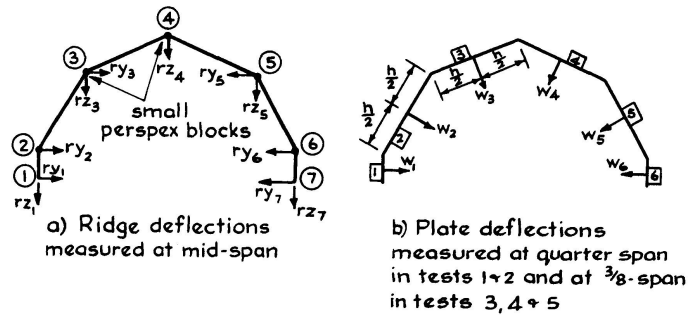

Fig. 8. Positions of Deflection Measurements during Tests.

In addition to the deflection measurements, the strains set up in each of the models with openings were recorded by means of electrical resistance strain gauges. These gauges were arranged in a T pattern, with one pair on the top surface of the model and another pair at the corresponding position on the lower surface, so that both the direct and bending stresses in the longitudinal and transverse directions could be calculated. Twenty-eight strain gauges were used in each test, and these were positioned at the $\frac{3}{8}$ -span and $\frac{1}{4}$ -span cross-sections, as shown in Figure 9, so that the stress distribution across a solid section and across a section containing openings could be compared.

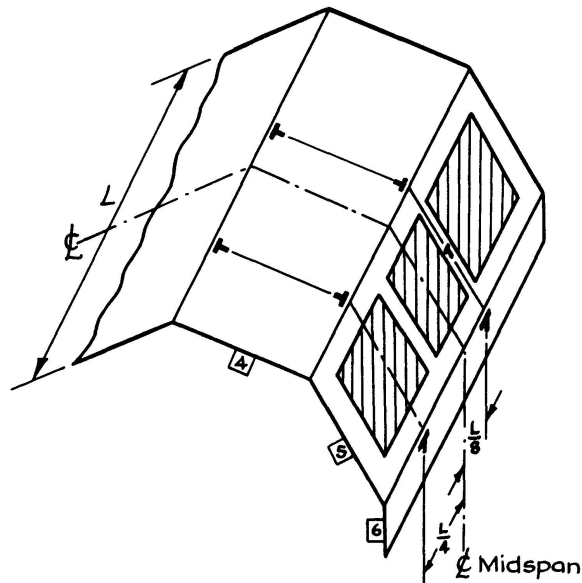

Fig. 9. Strain Gauge Positions for the Model in Tests 3, 4 and 5.

In all tests, several load increments were applied to the models and all of the load/deflection and load/strain relationships obtained exhibited good linear characteristics. The required symmetry of readings about the longitudinal centre line was observed in all tests and the negligible deflection and strain values which were recorded for each model in its final unloaded state showed that the elastic limit had not been exceeded in any test.

4. Finite Element Solutions

The application of the finite element method to the analysis of folded plate structures has been discussed in detail by the authors in a previous report³. In this solution, rectangular elements were used in which the two in-plane displacements associated with plane stress and the three out-of plane displacements associated with plate bending were considered at each of the four nodes of the element, and six force and displacement components were considered at each nodal point in the global co-ordinate system. The accuracy of the proposed finite element approach was established by comparing results given by the method to results obtained from the elasticity method⁴ of folded plate analysis. This accuracy was further confirmed in a subsequent report⁵, in which finite element results were compared to experimental values obtained from a series of tests on both trough-type and vault-type folded plate models. Then, more recently², the extension of the finite element method to the analysis of folded plates supported by intermediate columns was discussed, and the accuracy of the method was again established by a comparison of experimental and theoretical results.

The main advantages of the finite element method arise from the fact that the method involves the subdivision of a structural continuum, such as a folded plate surface, into a number of discrete elements, which are considered to be interconnected at their corners only; typical subdivisions are shown in Figure 10. A stiffness matrix is established for each individual element, and the elements are then assembled together so as to satisfy equilibrium and compatibility conditions at their points of interconnection.

Since equilibrium and compatibility equations are set up at each nodal point, it follows that any point loading condition, or any restraint of a displacement component, such as that imposed by a column support, may be specified at each node point. Thus, folded plates having intermediate column supports, as in Tests 2, 4 and 5 of the present experimental investigation, may be conveniently analysed by the finite element method by ensuring, in the first place, that the structure is subdivided so that a node point of the mesh coincides with each support position, and then specifying that the required components of displacement are zero at the relevant node points.

Furthermore, since the folded plate surface is divided into a number of smaller elements, as in Figure 10, and since the stiffness matrix of each element is separately established, the thickness and elastic properties of each individual element can be specified independently. Consequently, in a finite element solution, the variation of any property over the surface area of the structure can be simulated simply by assigning appropriate values to the individual elements.

The main disadvantage of the finite element method is that, since several force and displacement components are considered at each node point of the mesh, a large number of simultaneous equations must be solved during the analysis. The total number of equations to be solved in any analysis is equal to the product of the number of node points and the number of degrees of freedom considered at each node, so that, for the meshes shown in Figure 10, a total of 1,122 simultaneous equations must be solved, despite the fact that only one-quarter of the complete structure has to be considered in the analysis because of the symmetry of

the structure and its loading. The overall structural stiffness matrix in each of these solutions would thus contain $1,122 \times 1,122$ terms, so that its direct inversion and consequent solution of the problem would be impossible because of limitations on computer storage space.

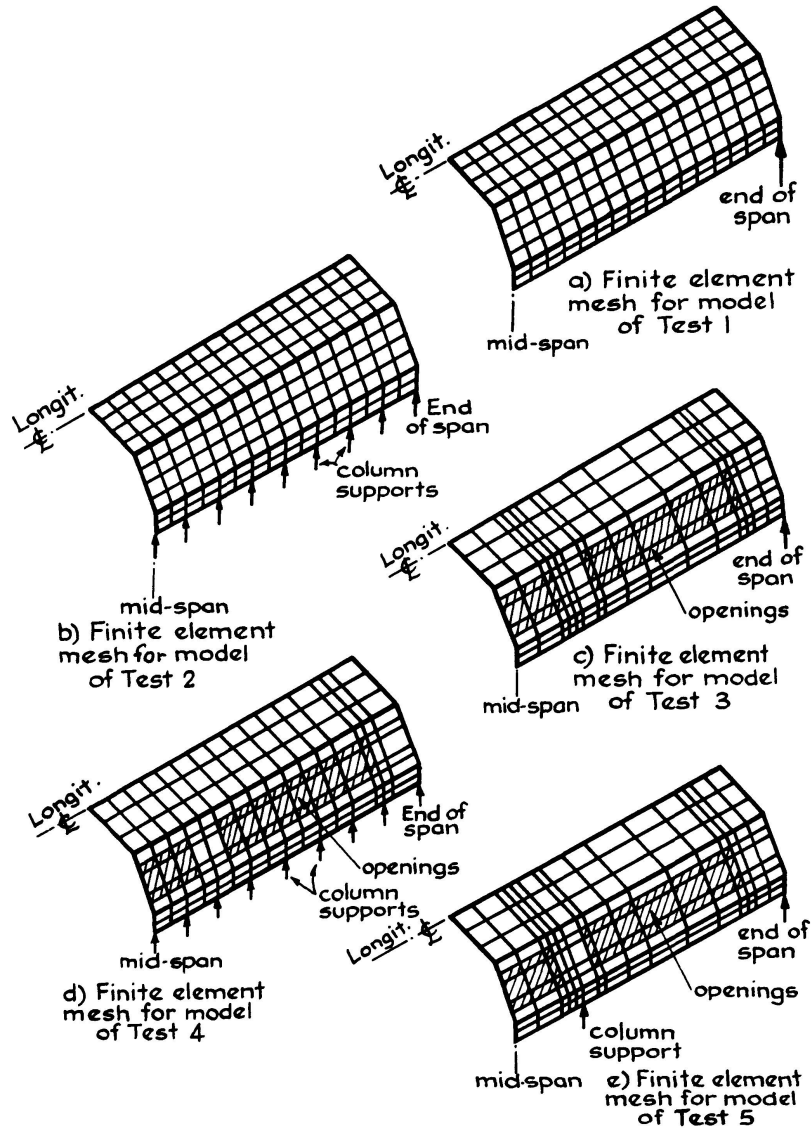

Fig. 10. Illustration of Meshes used in the Finite Element Solutions.

However, because each nodal point of the mesh is only connected to the 8 nodes immediately adjacent to it, the overall structural stiffness matrix will contain many zero terms, and a careful numbering of the node points will ensure that all the non-zero terms are grouped in a narrow band around the leading diagonal of the matrix. Special techniques have been developed to provide the inverse of such banded matrices in a very efficient manner, wherein only the non-zero terms within the narrow band need be stored, thus greatly reducing the demands on computer storage space.

The technique employed in the computer programme developed for the present investigation was the tri-diagonalization method originally proposed by PARIKH,

Rossow and BIGGS⁶. The efficiency of this technique depends upon the use of a regular mesh, i.e. a mesh in which the same number of elements is taken across each section of the structure, as in Figure 10. Thus, in order to maintain the regularity of the mesh for the models containing openings in Tests 3, 4 and 5, elements were actually positioned within the cut-out regions, as shown in Figures 10(c), 10(d) and 10(e), and the stiffness of the elements within these regions was then specified to be zero. This provides a good example of the adaptability of the finite element method in the specification of variable material properties.

The use of such techniques to maintain the regularity of the mesh would also be advantageous if the use of automatic mesh generation and data preparation routines was being contemplated. Such automatic techniques are easier to develop and prove to be more efficient when applied to a regular mesh.

The meshes used in the present investigation, as illustrated in Figure 10, were selected for three main reasons. In the first place, previous convergence studies⁷ had established that such fine meshes were required to provide accurate results. Secondly, it was essential, as discussed earlier, that a node point of the chosen mesh should always coincide with each intermediate column support condition. Then, finally, since it was anticipated that high stress gradients would be set up in the regions adjacent to the corners of the openings, an attempt was made to grade the mesh and to position smaller elements within these areas. The rectangular elements employed in the present solution do not lend themselves so readily to mesh grading as do triangular elements, but the extent of the mesh grading carried out may be observed by comparing the meshes used for the models not containing openings, as shown in Figures 10(a) and 10(b), to those used for the models with openings, illustrated in Figures 10(c), 10(d) and 10(e).

5. Results

Although the finite element solution gives a comprehensive picture of the deflections, moments and stresses set up within a folded plate structure, only those values that were also measured experimentally will be presented in this report.

In Table 2, the ridge displacements at the mid-span cross-section and the displacements perpendicular to the planes of the plates, measured in each of the five tests, are compared to the finite element values. The notation and positive directions adopted for these displacements are as defined earlier in Figures 8(a) and 8(b).

In Figure 11, the theoretical and experimental values of the deflected positions of the ridges at the mid-span cross-section of each of the first four models are plotted. In Figure 11(a), the cross-sectional deformations of the models with and without openings, but with unsupported edges (i.e. in Tests 1 and 3), are compared, and a similar comparison is presented in Figure 11(b) for the models with supported edges (i.e. in Tests 2 and 4, where the columns were introduced at one-sixteenth span positions).

Table 2. Theoretical and Experimental Values of the Deflections of the Models.

Test No.	Model Type	Edge Support Condition	Solution	Ridge deflections at mid-span ($\text{mm} \times 10^{-3}$)						Plate deflections ($\text{mm} \times 10^{-3}$)					
				r_{z4}	$r_{y3} = r_{y5}$	$r_{z3} = r_{z5}$	$r_{y2} = r_{y6}$	$w_3 = w_4$	$w_2 = w_5$	$w_1 = w_6$	$w_3 = w_4$	$w_2 = w_5$	$w_1 = w_6$		
1	Without Openings	Free	Finite Element	180	-30.5	117	-338	at $1/4$ -span							
			Experimental	193	-43.2	102	-429	193	-107	-221					
2	Without Openings	Columns at $1/16$ -span	Finite Element	114	-48.3	7.6	-61.0	130	-91.4	-17.8					
			Experimental	147	-66.0	12.7	-78.7	155	-122	-22.9					
3	With Openings	Free	Finite Element	328	107	574	-767	at $3/8$ -span							
			Experimental	376	81.3	511	-742	495	9	-1029					
4	With Openings	Columns at $1/16$ -span	Finite Element	213	-66.0	66.0	-142	295	-279	-124					
			Experimental	211	-88.9	73.7	-127	290	-285	-112					
5	With Openings	Columns at $3/8$ -span	Finite Element	274	-55.9	147	-300	226	-211	-66.0					
			Experimental	284	-86.4	152	-254	211	-224	-60.0					

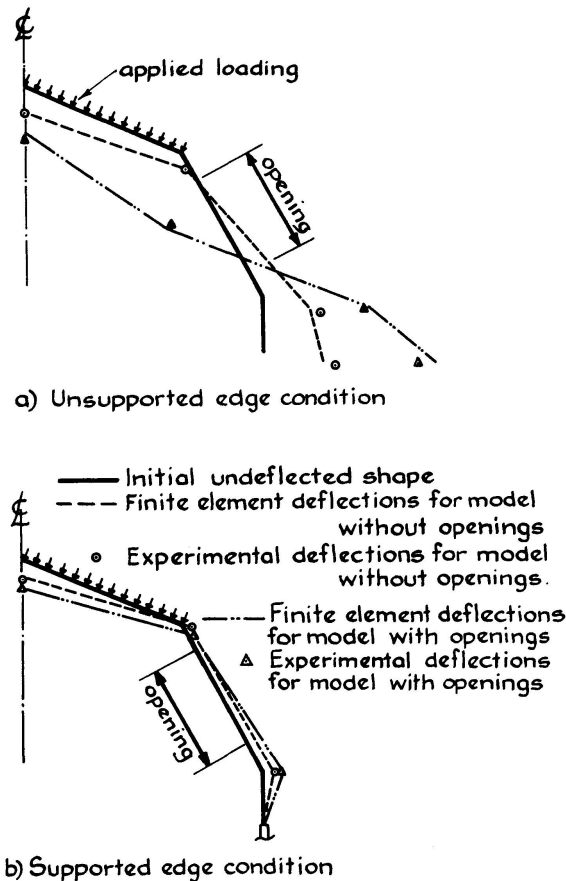

Fig. 11. Comparison of Deflected Shape of Cross-sections of Models with and without Openings.

Having compared the cross-sectional deformations, the variation along the span of the ridge deflections of the models with and without openings are next compared in Figures 12 and 13. The effects of the introduction of the openings on the structural behaviour may thus again be observed, and the extent of the openings is indicated on the horizontal axis in these diagrams. Curves are presented showing the values given by the finite element method, these curves having been plotted from the values predicted by the method at each of the 17 nodal points taken on the half-span. The experimentally measured ridge deflection values at the mid-, $\frac{3}{8}$ - and $\frac{1}{4}$ -span cross-sections are also included in Figures 12 and 13 for comparison with the theoretical results.

In Figure 12, the ridge deflections of the models with free edges, (i.e. in Tests 1 and 3) are compared, the vertical deflections being included in Figure 12(a) and the horizontal deflections being shown in Figure 12(b). Similar comparisons are presented in Figures 13(a) and 13(b) for the models with the columns introduced at the sixteenth-span positions underneath the longitudinal edges (i.e. in Tests 2 and 4). In these two tests, however, the introduction of the columns provided a practically fully clamped edge condition and reduced both the vertical and horizontal edge movements to negligible proportions, so that these edge movements are not included in Figure 13.

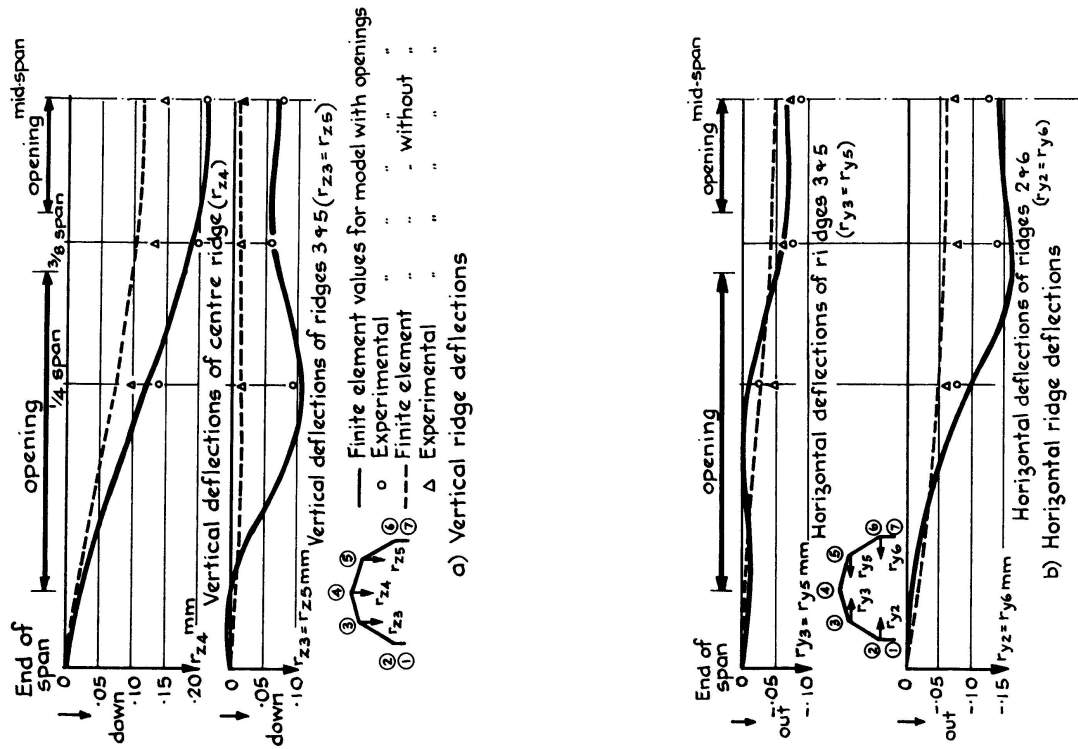

Fig. 12. Comparison of the Variation along the Span of the Ridge Deflections of the Models with and without Openings-Free Edge Conditions.

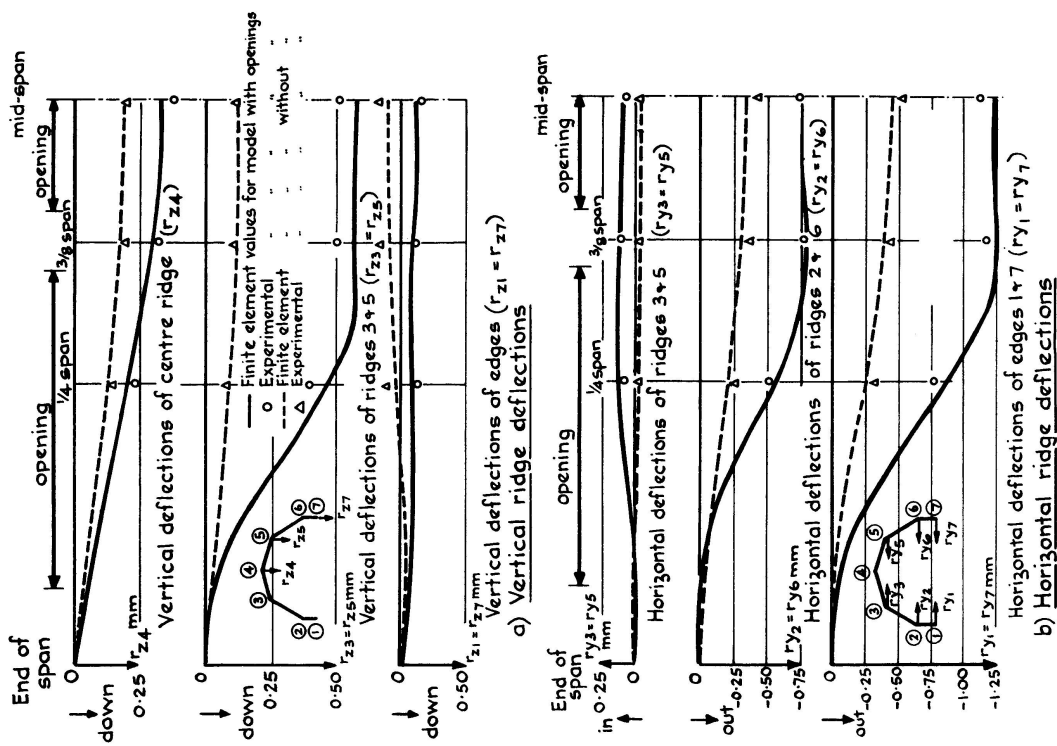

Fig. 13. Comparison of the Variation along the Span of the Ridge Deflections of the Models with and without Openings-supported Edge Conditions.

Finally, in Figures 14 and 15, the distribution of the transverse moments and longitudinal stresses across the $\frac{3}{8}$ -span and $\frac{1}{4}$ -span cross-sections of two of the models containing openings are shown. Figure 14 illustrates the moment and stress distribution for the model with free edges in Test 3, the moments and stresses at $\frac{3}{8}$ -span being shown in Figure 14(a) and those at $\frac{1}{4}$ -span being shown in Figure 14(b). Figure 15 illustrates the corresponding values for the model with supported edges in Test 4.

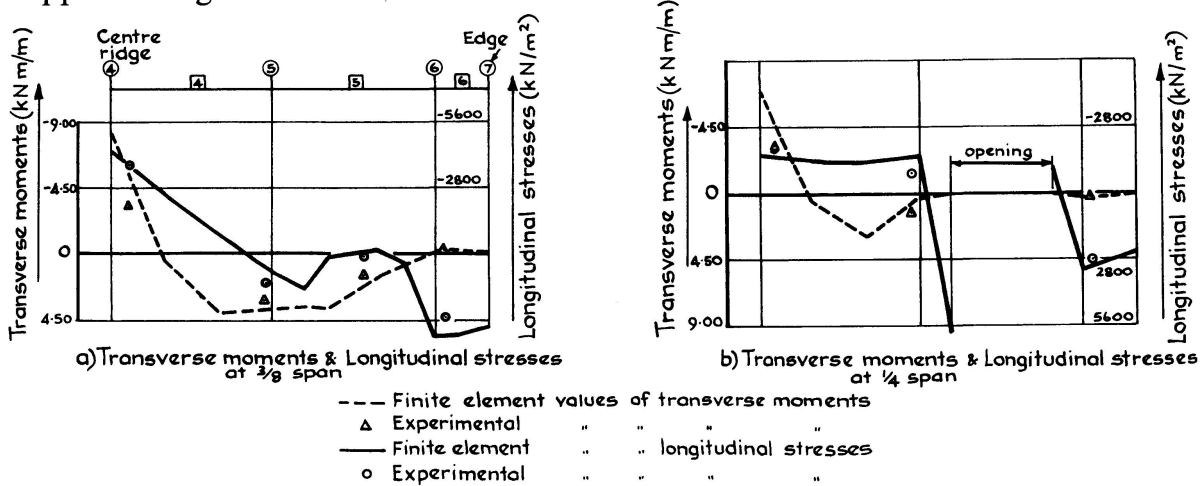

Fig. 14. Transverse Moments and Longitudinal Stresses set up in the Model with Openings - Free Edge Conditions (Test 3).

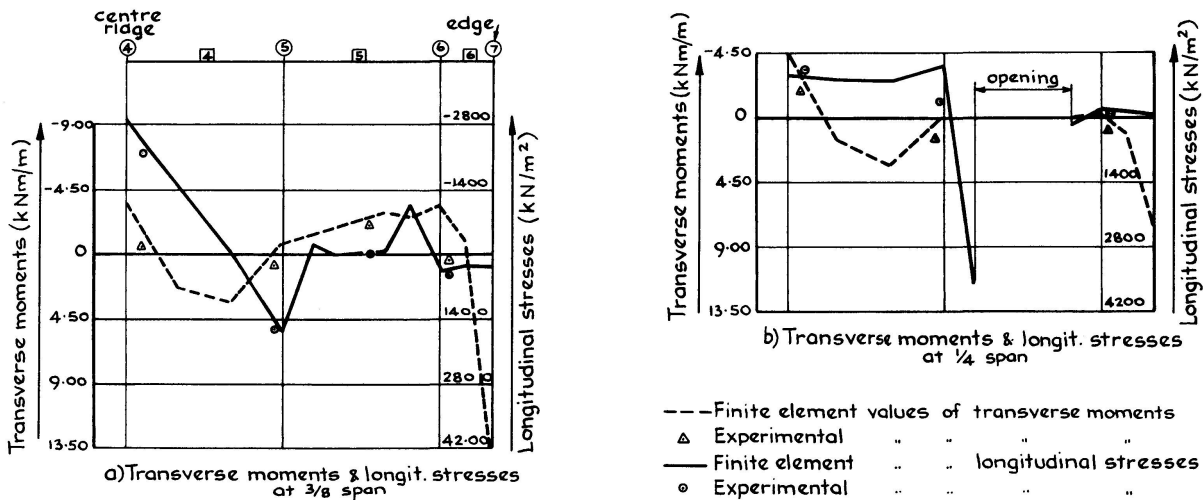

Fig. 15. Transverse Moments and Longitudinal Stresses set up in the Model with Openings - Supported Edge Conditions (Test 4).

As may be seen from Figure 2, where the details of the models tested were presented, the $\frac{3}{8}$ -span cross-section of the models was located mid-way between the opening, whereas the openings extended through the $\frac{1}{4}$ -span cross-section. Figures 14 and 15, therefore, provide a comparison between the moment and stress distribution across a completely solid cross-section, i.e. at $\frac{3}{8}$ -span, and across a section containing an opening, i.e. at $\frac{1}{4}$ -span.

Both finite element and experimental values are included in Figures 14 and 15 so that the predicted and measured moment and stress distributions may be compared.

6. Discussion of Results

From the results obtained, it is apparent that, as would be expected, the introduction of the large window openings caused a significant reduction in the overall stiffness of the folded plate model. This reduction in stiffness is most marked in the models having free edges and is well illustrated in Figure 11(a), where the mid-span cross-sectional deformations of the models with and without openings are compared. The diagram shows the gross change in the deformed shape of the cross-section resulting from the introduction of the openings, this change being associated with a significant increase (of up to 400%) in the magnitude of the ridge deflections, particularly for those ridges adjacent to the openings.

In addition to having a significant influence on the deflected shape of the mid-span cross-section, the introduction of the openings also led to a change in the longitudinal variation of the ridge deflections, as may be observed from Figures 12 and 13. For example, for the models with free edges, Figures 12(a) and 12(b) show that, because of the introduction of the openings, the deflected shape was modified so that the maximum values of the ridge deflections extended, at a practically constant value, from mid-span to well beyond the $\frac{3}{8}$ -span position.

The longitudinal stresses set up in the models were also increased significantly by the introduction of the openings. This is illustrated in Figures 14 and 15 where the stresses obtained near the edges of the opening at the $\frac{1}{4}$ -span cross-sections of the models with both supported and unsupported edges are seen to be greatly in excess of the stresses obtained at the $\frac{3}{8}$ -span cross-sections of these models. These $\frac{3}{8}$ -span cross-section did, of course, coincide with a position mid-way between the openings in these models.

This comparison of the deflection and stress values for the models with and without openings thus shows clearly that such large openings should not be introduced in practice without the provision of a ring beam to stiffen the edges of the opening. In this way, the structural efficiency of the folded plate system could be maintained without a great increase in material costs. It is therefore essential that studies be conducted to enable designers to determine the optimum proportions of the ring beams; to date, little information on the design of this detail is available to the designer.

The results presented also illustrate the effectiveness of the edge supporting columns in reducing the cross-sectional deformations of the folded plate. A comparison of the deformed cross-sectional shapes shown in Figures 11(a) and 11(b) for the models with unsupported and supported edges respectively, show a great decrease in the deformations of both the models with and without openings, resulting from the introduction of the supporting columns at the one-sixteenth span positions. Even the introduction of columns at the $\frac{3}{8}$ -span position only, as in Test 5, greatly reduces the deflections of the models, as may be observed from the values listed in Table 2, and such an arrangement, in which only two columns are introduced under each edge, has the great advantage of offering very little interference to the access into the covered area. Thus, when it is necessary to provide column supports for folded plates containing openings, a careful positioning of these columns to coincide with locations between the openings can lead to efficient design solutions.

In the results presented for all the tests carried out, a satisfactory degree of agreement is observed between the values predicted by the finite element method and those measured experimentally. This is true for the cross-sectional deformations plotted in Figure 11, for the longitudinal variation of ridge deflections shown in Figures 12 and 13 and for the moment and stress distributions plotted in Figures 14 and 15. When the possible sources of experimental error, such as the difficulties inherent in accurately folding a model from a flat sheet, the difficulties in accurately measuring the vertical deflections of a ridge that also moves horizontally, etc., are taken into consideration, it may be concluded that the observed deviations between the theoretical and experimental results are generally within the anticipated range of experimental accuracy.

Although both the introduction of the discreet column supports and of the openings introduced regions of stress concentrations into the models, the graded meshes employed in the finite element solutions were obviously capable of representing the overall structural behaviour to an acceptable degree of accuracy. However, within the regions of stress concentration, particularly close to the corners of the openings, significant discontinuities were observed in the moment and stress values calculated for adjacent elements. Thus, an even finer mesh would be required to provide accurate theoretical results in these regions of high stress gradient and the adoption of a finite element solution employing triangular elements, in place of the rectangular elements used in the present solution, would facilitate an extensive mesh grading of this nature.

7. Conclusions and Design Recommendations

The experimental and theoretical results obtained during this investigation enable three main conclusions to be drawn.

In the first place, the introduction of large window openings into folded plate structures greatly reduces the inherent stiffness of the structure. Very great increases of deflection, transverse moment and longitudinal stress values as a result of the introduction of such openings have been observed during the investigation. When such openings have to be provided they should be stiffened with edge ring beams to restore the structural efficiency of the folded plate system and this can be accomplished at very little additional cost.

Secondly, the investigation has shown the effectiveness of edge supporting columns in reducing the cross-sectional deformations of folded plates. Since the largest deformations of a typical folded plate occur at the free edge positions, the introduction of columns to support these edges is much more effective than the introduction of columns at positions underneath internal ridges. Edge columns have the further great advantage of not providing any interference within the covered area; the use of internal columns would provide obstructions which could prove to be unacceptable in many cases, e.g., during the design of sports halls. The present investigation has also shown that careful positioning of the edge supporting columns can lead to a great increase in structural stiffness with the use of only a few columns, so that very little interference would then be offered to the access into the covered area.

Finally, the accuracy of the finite element method in the analysis of folded plates containing openings and supported by intermediate columns has been firmly established. The adaptability of the method has been illustrated by its ability to cope with the various structural arrangements considered during the investigation. The method could be easily extended to take into account the stiffening action of edge ring beams if these were provided around the perimeter of the window openings. However, the amount of computational effort required in obtaining a finite element solution should be appreciated; for example, in each of the analyses carried out in the present investigation, the solution of some 1,122 simultaneous equations was required, despite the fact that only one-quarter of the complete structure was analysed because of the symmetry of the structure and its loading. These heavy demands on computer time and storage space, coupled with the labour involved in the preparation of data and in the interpretation of results, make the method very expensive when used as a design tool. The method is more suited to carrying out a check analysis of a structure after the proportions of the structure have been estimated by some more approximate technique.

Future studies are envisaged which will be directed at providing rules for proportioning the ring beams recommended for stiffening the perimeter of window openings. A close study of the stress distributions in the immediate vicinity of such openings and in regions adjacent to column supports is also planned.

8. Notation

All terms are defined in Figures 8(a) and 8(b).

rz_n	vertical deflection of ridge n .
ry_n	horizontal deflection of ridge n .
w_n	deflection perpendicular to plate n at the mid-width position on the plate.

9. References

1. EVANS, H.R., and ROCKEY, K.C.: A Critical Review of the Methods of Analysis for Folded Plate Structures. Proc. Instn. Civ. Engrs., 1971, 49, June, pp. 171-192.
2. EVANS, H.R.: An Experimental and Theoretical Study of the Behaviour of Folded Plates Supported by Intermediate Columns, to be published.
3. ROCKEY, K.C., and EVANS, H.R.: A Finite Element Solution for Folded Plate Structures. Proceedings of Conference on Space Structures, Oxford, Blackwell, 1967, pp. 165-188.
4. GOLDBERG, J.E., and LEVE, H.L.: Theory of Prismatic Folded Plate Structures. IABSE, Vol. 17, 1957, pp. 59-86.
5. ROCKEY, K.C., and EVANS, H.R.: A Study of the Behaviour of Folded Plate Structures. The Structural Engineer, Vol. 49, No. 4, April 1971, pp. 189-197.
6. PARIKH, K.S., ROSSOW, R.C., and BIGGS, J.M.: Analysis of Large Pin-connected Three-dimensional Framework. Symposium on the use of Computers in Civil Engineering, C.r. Proc. 2, 1962.
7. EVANS, H.R.: The Analysis of Folded Plate Structures. University of Wales, Ph. D. Thesis, 1967.

Summary

The paper describes an experimental and theoretical study of the behaviour of folded plate structures containing large window openings and supported by intermediate columns. The large reduction in structural stiffness resulting from the introduction of such openings is illustrated, together with the effectiveness of edge supporting columns in reducing the deformations of the structure. Finally, the application of the finite element method to the analysis of such structures is discussed and the accuracy and adaptability of the method is established.

Résumé

L'article traite d'une étude expérimentale et théorique sur le comportement de structures plissées avec des grandes ouvertures et supportées par des colonnes intermédiaires. On met en évidence la grande réduction de la rigidité due aux ouvertures ainsi que la réduction des déformations de la structure due aux colonnes placées sous les plis. Finalement on discute l'application de la méthode des éléments finis dans le calcul de telles structures ainsi que de la précision et la souplesse de la méthode.

Zusammenfassung

Der Beitrag behandelt eine experimentelle und theoretische Untersuchung über das Verhalten von durch Zwischenstützen getragenen Faltenwerken mit grossen Fensteröffnungen. Die grosse Abminderung der Steifigkeit der Tragstruktur infolge solcher Öffnungen wird aufgezeigt, desgleichen die Wirksamkeit der Zwischenstützen auf das Verformungsverhalten. Schliesslich wird die Methode der finiten Elemente zur Berechnung solcher Faltenwerke diskutiert und die Genauigkeit und Anpassungsmöglichkeit der Methode nachgewiesen.

Leere Seite
Blank page
Page vide