

Safety, serviceability and efficiency of limit design for reinforced concrete beams and frames

Autor(en): **Cohn, M.Z. / Burnett, E.F.P. / Grierson, D.E.**

Objektyp: **Article**

Zeitschrift: **IABSE publications = Mémoires AIPC = IVBH Abhandlungen**

Band (Jahr): **29 (1969)**

PDF erstellt am: **26.09.2024**

Persistenter Link: <https://doi.org/10.5169/seals-22907>

Nutzungsbedingungen

Die ETH-Bibliothek ist Anbieterin der digitalisierten Zeitschriften. Sie besitzt keine Urheberrechte an den Inhalten der Zeitschriften. Die Rechte liegen in der Regel bei den Herausgebern.

Die auf der Plattform e-periodica veröffentlichten Dokumente stehen für nicht-kommerzielle Zwecke in Lehre und Forschung sowie für die private Nutzung frei zur Verfügung. Einzelne Dateien oder Ausdrucke aus diesem Angebot können zusammen mit diesen Nutzungsbedingungen und den korrekten Herkunftsbezeichnungen weitergegeben werden.

Das Veröffentlichen von Bildern in Print- und Online-Publikationen ist nur mit vorheriger Genehmigung der Rechteinhaber erlaubt. Die systematische Speicherung von Teilen des elektronischen Angebots auf anderen Servern bedarf ebenfalls des schriftlichen Einverständnisses der Rechteinhaber.

Haftungsausschluss

Alle Angaben erfolgen ohne Gewähr für Vollständigkeit oder Richtigkeit. Es wird keine Haftung übernommen für Schäden durch die Verwendung von Informationen aus diesem Online-Angebot oder durch das Fehlen von Informationen. Dies gilt auch für Inhalte Dritter, die über dieses Angebot zugänglich sind.

Safety, Serviceability and Efficiency of Limit Design for Reinforced Concrete Beams and Frames

Sécurités de rupture et de service, et rendement du dimensionnement à la rupture de poutres et de portiques en béton armé

Sicherheit, Nutzbarkeit und Leistung einer Bemessung auf Bruch von Stahlbetonbalken und -rahmen

M. Z. COHN E. F. P. BURNETT D. E. GRIERSON
Prof. of Civil Eng. Assist. Prof. of Civil Eng. Assist. Prof. of Civil Eng.
University of Waterloo, Waterloo, Ontario, Canada

Introduction

A variety of methods is presently available for the analysis and design of reinforced concrete structures allowing for different degrees of moment redistribution [1] . . . [8].

Recently a comprehensive study was devoted to the presentation of the specific techniques, features, field of application and limitations of these methods [9].

The study was prompted by the need for providing structural engineers with an overall view of the potential applications of limit design and with some illustration of the problems involved in the available approaches. Two important results of this study [9] are noted:

1. A set of objective criteria for quantitatively comparing structural design solutions evolved.
2. Some theoretical developments in the ultimate load design [10], optimal design [11], [12], compatibility analysis [13] and computer techniques in plastic analysis [14] followed.

While the theoretical developments mentioned above are reported elsewhere, this paper elaborates on the objective criteria first presented in [9],

i. e., the collapse safety, serviceability and efficiency of limit design solutions and methods.

The paper does not attempt to recommend the application of any specific method in preference to the other. It only provides the designer with a set of standard criteria for evaluating various limit design methods [2] . . . [8] with respect to the currently used ultimate strength design (USD) method [1].

Design Criteria and Limit Design Methods

A summary of the design criteria and basic assumptions adopted in various methods is reproduced in Table 1 [9].

The ultimate safety is expressed by the ultimate load factor for a particular loading arrangement, which is defined as the ratio of the collapse load for the given loading arrangement to the corresponding service load, $\lambda^+ = W_u^+/W$. The ultimate safety parameter (u. s. p.) u_i , can be introduced as a convenient measure of the structural safety, and is defined by the ratio of the ultimate to the specified load factors, i. e., $u_i = \lambda_i^+/\lambda_0$.



The serviceability is basically dependent on the safety against the first section reaching its ultimate stage. In brief, this is here referred to as yield safety, and is measured by the yield load factor. This is defined as the ratio of the load at which the ultimate moment is reached at section j (first plastic hinge load) and the service load, i. e., $\lambda_{1j} = W_{1j}/W$. A convenient measure of the yield safety of a critical section for a particular loading arrangement is the yield safety parameter (y. s. p.), which is the ratio of the yield load factor of the section to the specified overall load factor of the structure, i. e., $x_j = \lambda_{1j}/\lambda_0$.

The compatibility condition ensures that section behaviour in the inelastic range follows the load-deformation curve of the material. For the elastic-plastic material idealization it reduces to a limitation of the inelastic rotations, i. e., $\theta_j \leq \theta_{pj}$ [16]. This condition presupposes a limiting concrete strain which varies with different methods, as listed in line 3 of table 1.

The efficiency of a particular design solution may be considered in relation to total or initial cost, material consumption or other criteria. When geometry, concrete sections and shear reinforcement are maintained constant for various solutions, a reasonable criterion of economy is the consumption of flexural reinforcing steel. If V_e and V_k are the steel volumes required by the elastic, U.S.D. solution and by limit design respectively, the ratio $v_k = V_k/V_e$ is a measure of the relative steel consumption in limit vs. elastic design, and is referred to in this and previous studies [9], [11] as the efficiency index of the structure.

This paper suggests that ratios u_i , x_j and v_k , enable a meaningful comparison of design solutions to be made in relation to safety, serviceability and efficiency, respectively.

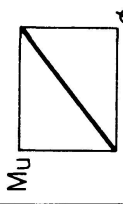
Table 1. Design Criteria and Basic Assumptions for Various Limit Design Methods

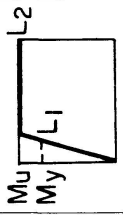
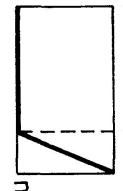
Class of method		Elastic			Compatibility			Serviceability		
		USD	BLD	SLD	LRD	FRD	OLD			
Design criteria	Ultimate safety λ_0 against	Ist yield or crushing	Ist crushing	Structure becoming statically determinate	Formation of at least one mechanism	Formation of m mechanisms	Formation of mechanisms			
	Serviceability $\lambda_1 =$	λ_0	(1.39)	(1.2)		1.2				
	Compatibility $\theta_i \leq \theta_{pi}$ with $\epsilon_u \leq$	0.3%	0.38%	1%		(0.4%)				
	Efficiency $v_k = V_k/V_e$	1.0	—	—	—	—	Min. V_k			
	Loading scheme	Any	Any	Full load		Any				
	Ultimate load	W_u	$0.9 W_u$		$W_u = \lambda_0 (W_D + W_L) = 1.5 W_D + 1.8 W_L$					
Basic assumptions	Design moment	$M_p = \phi b d^2 q (1 - 0.59 q)$ with $\phi = 0.9$								
	Material behaviour									

() Not considered explicitly as part of the method.

The following methods are investigated:

1. USD: "Ultimate Strength Design" as proposed in the ACI Building Code [1], currently accepted in American design practice, and implying an elastic structural analysis and plastic sectional design.
2. BLD: "Bi-Linear Design" as proposed by H. A. SAWYER, JR., [2], [3] and similar in principle to the method of imposed rotations by MACCHI [15].
3. SLD: "Simplified Limit Design", as proposed by A. L. L. BAKER [4], [5] with amendments to include a serviceability criterion and consistency in the ultimate conditions [10].
4. LRD and FRD: "Limited and Full Redistribution Designs", as proposed by M. Z. COHN, [7], [8], formerly referred to as OLD 2 and OLD 1 methods respectively, [6].
5. OLD: "Optimum Limit Design" as proposed by M. Z. COHN and D. E. GRIERSON [8], [11].

Methods 2., 3. and 4. above have been selected because they have a relatively higher potential for application, are representative of methods in the

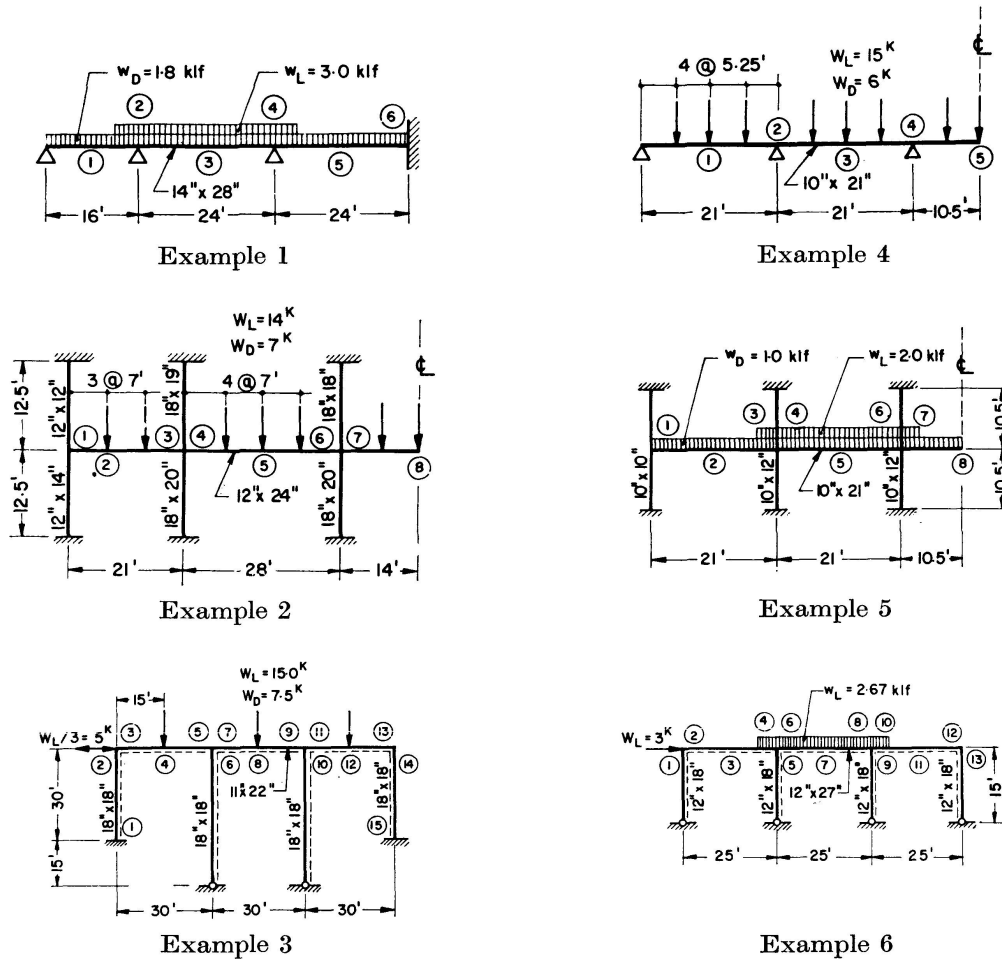

Fig. 1. Geometry and loading of 6 examples of building structures.

“compatibility” and “serviceability” classes [7] and have been retained for consideration by the Joint ASCE-ACI Committee 428, Limit Design.

Methods 1. and 5. have been included because they represent the extreme trends in relation to the safety, serviceability and efficiency of structural designs.

The lines in table 1 are self-explanatory and summarize the basic assumptions and criteria adopted in various limit design methods illustrated in the paper.

Examples of Building Structures

Design solutions based on various methods are studied by reference to six examples of building structures to which limit design may safely be applied at this time. It is believed that limit design principles are acceptable for all the examples investigated because flexural action prevails and, with proper detailing, shear, instability and other effects may be neglected. These examples are indicated in Fig. 1 and consist of two continuous beams, two multi-storey braced frames and two single-storey, unbraced frames. The braced frames were

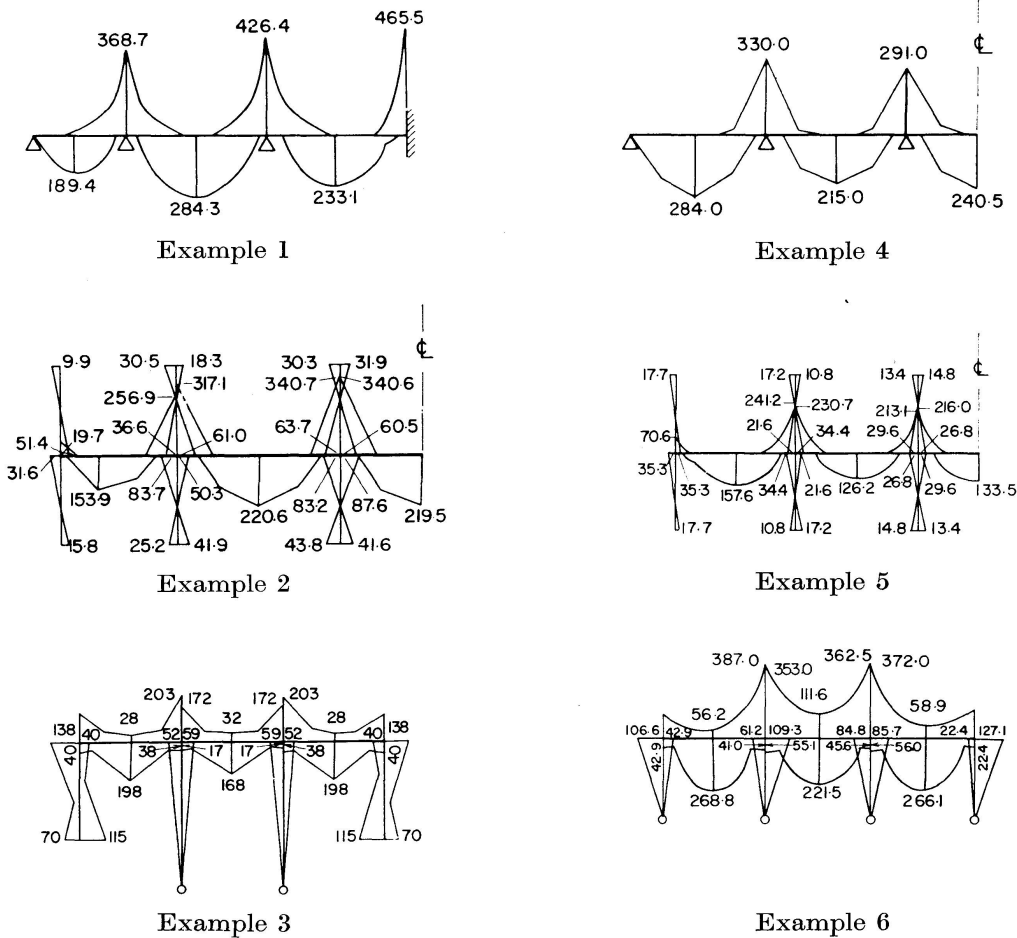

Fig. 2. Factored elastic moment envelopes (USD theoretical solutions).

Table 2. Design Solutions and Yield Safety: M_{pj} and x_j Values for Continuous Beam Examples 1 and 4

Example	Section (j)	USD		BLD		SLD		LRD		FRD		OLD	
		M_{pj}	x_j	M_{pj}	x_j	M_{pj}	x_j	M_{pj}	x_j	M_{pj}	x_j	M_{pj}	x_j
1	1	189.4	1.000	175.0	0.923	143.0	0.755	170.5	0.900	135.0	0.712	135.0	0.712
	2	368.7	1.000	335.0	0.910	270.0	0.732	310.0	0.840	289.0	0.785	271.3	0.736
	3	284.3	1.000	247.0	0.870	297.0	1.045	256.0	0.900	271.0	0.950	234.3	0.824
	4	426.4	1.000	385.0	0.905	331.0	0.777	358.0	0.840	334.0	0.785	426.4	1.000
	5	233.1	1.000	235.0	1.008	265.0	1.138	210.0	0.900	233.0	1.000	166.0	0.712
	6	465.5	1.000	385.0	0.826	331.0	0.710	392.0	0.840	366.0	0.785	408.1	0.877
4	1	284.0	1.000	—	—	275.5	0.970	255.5	0.900	260.5	0.916	253.0	0.889
	2	330.0	1.000	—	—	231.0	0.700	244.5	0.740	235.0	0.712	251.0	0.760
	3	215.0	1.000	—	—	168.0	0.782	193.3	0.900	157.0	0.732	150.3	0.700
	4	291.0	1.000	—	—	205.0	0.704	215.5	0.740	207.0	0.712	203.0	0.700
	5	240.5	1.000	—	—	181.5	0.756	216.5	0.900	171.0	0.712	172.3	0.726

Table 3. Design Solutions and Yield Safety: M_{pj} and x_j Values for Braced Frame Examples 2 and 5

Example	Section (j)	USD		SLD		LRD		FRD		OLD	
		M_{pj}	x_j	M_{pj}	x_j	M_{pj}	x_j	M_{pj}	x_j	M_{pj}	x_j
2	1	51.4	1.000	48.0	0.940	47.0	0.915	46.0	0.890	51.4	1.000
	2	153.9	1.000	155.0	1.010	141.0	0.915	143.0	0.930	153.9	1.000
	3	256.9	1.000	210.0	0.820	235.0	0.915	229.9	0.890	185.6	0.723
	4	317.1	1.000	275.0	0.870	290.9	0.915	282.0	0.890	317.1	1.000
	5	220.6	1.000	236.0	1.070	202.0	0.915	208.0	0.940	170.5	0.773
	6	340.7	1.000	275.0	0.810	312.0	0.915	303.0	0.890	340.7	1.000
	7	340.6	1.000	275.0	0.810	312.0	0.915	303.0	0.890	340.6	1.000
	8	219.5	1.000	236.0	1.070	202.0	0.915	197.0	0.890	159.6	0.727
5	1	70.6	1.000	70.0	0.992	63.3	0.897	56.7	0.803	70.6	1.000
	2	157.6	1.000	169.2	1.074	141.4	0.897	155.8	0.988	125.1	0.794
	3	241.2	1.000	170.0	0.706	216.2	0.897	194.0	0.803	241.2	1.000
	4	230.7	1.000	170.0	0.737	207.0	0.897	185.3	0.803	230.7	1.000
	5	126.2	1.000	124.6	0.986	113.2	0.897	102.8	0.814	89.1	0.706
	6	213.1	1.000	155.0	0.727	191.2	0.897	171.4	0.803	153.9	0.722
	7	216.0	1.000	155.0	0.717	193.9	0.897	173.7	0.803	183.1	0.866
	8	133.5	1.000	132.5	0.993	119.8	0.897	107.5	0.803	94.3	0.706

designed assuming that the requirements of articles 905 and 914 of ACI 318-63 [1] apply.

Examples 1, 2 and 3 are the same as in reference [9] and represent fairly typical loads, geometries and amounts of plastic redistribution. Examples 4, 5 and 6 have been added in an attempt to explore higher limits of redistribution for the same classes of structures.

The five methods mentioned in the previous section have been successively applied to the six examples in Fig. 1. Details of the analysis and design pro-

Table 4. Design Solutions and Yield Safety: M_{pj} and x_j Values for Unbraced Frame Examples 3 and 6

Exam- pls	Sec- tion (j)	USD		BLD		SLD		LRD		OLD											
		M_{pj}^+	x_j^+	M_{pj}^-	x_j^-	M_{pj}^+	x_j^+	M_{pj}^-	x_j^-	M_{pj}^+	x_j^+	M_{pj}^-	x_j^-								
3	1	138.0	1.200	138.0	1.970	120	1.043	120	1.715	110.0	0.955	110.0	1.572	107.0	0.930	107.0	1.530	97.2	0.847	97.2	1.392
	2	138.0	3.450	138.0	1.000	120	3.000	120	0.870	110.0	2.750	110.0	0.797	107.0	2.680	107.0	0.776	97.2	2.436	97.2	0.706
	3	40.0	1.000	138.0	1.000	40	1.000	120	0.870	40.0	1.000	110.0	0.797	40.0	1.000	107.0	0.776	28.3	0.706	97.2	0.706
	4	198.0	1.000	28.0	1.000	180	0.910	28	1.000	167.0	0.843	28.0	1.000	164.0	0.828	28.0	1.000	164.0	0.828	19.8	0.706
	5	38.0	1.000	203.0	1.000	38	1.000	180	0.887	38.0	1.000	160.0	0.788	38.0	1.000	155.0	0.763	26.8	0.706	172.0	0.847
	6	59.0	1.000	59.0	1.135	66	1.118	66	1.270	50.0	0.847	50.0	0.961	42.0	0.712	42.0	0.807	41.7	0.706	41.7	0.801
	7	38.0	2.235	203.0	1.182	38	2.235	180	1.045	38.0	2.235	160.0	0.929	38.0	2.235	155.0	0.901	26.8	1.578	172.0	1.000
	8	168.0	1.000	32.0	1.000	140	0.833	32	1.000	140.0	0.833	32.0	1.000	148.0	0.882	32.0	1.000	118.5	0.706	22.6	0.706
6	1	42.9	1.000	106.6	1.000	—	—	—	—	25.8	0.600	83.3	0.782	25.8	0.600	95.8	0.900	25.8	0.600	93.2	0.875
	2	42.9	1.000	106.6	1.000	—	—	—	—	25.8	0.600	83.3	0.782	25.8	0.600	95.8	0.900	25.8	0.600	93.2	0.875
	3	268.8	1.000	56.2	1.000	—	—	—	—	260.0	0.966	33.8	0.600	228.5	0.850	33.8	0.600	177.5	0.660	33.8	0.600
	4	41.0	1.000	387.0	1.000	—	—	—	—	24.6	0.600	260.0	0.672	24.6	0.600	282.5	0.729	24.6	0.600	387.0	1.000
	5	109.3	1.000	61.2	1.000	—	—	—	—	66.0	0.603	36.8	0.600	74.0	0.677	36.8	0.600	65.6	0.600	36.8	0.600
	6	55.1	1.000	353.0	1.000	—	—	—	—	33.1	0.600	260.0	0.736	33.1	0.600	212.0	0.600	33.1	0.600	353.0	1.000
	7	221.5	1.000	111.6	1.000	—	—	—	—	180.0	0.812	66.8	0.600	180.5	0.815	66.8	0.600	142.0	0.642	66.9	0.600
	8	45.6	1.000	362.5	1.000	—	—	—	—	27.4	0.600	260.0	0.717	27.4	0.600	264.5	0.729	27.4	0.600	362.5	1.000
	9	85.7	1.000	84.8	1.000	—	—	—	—	57.5	0.600	50.9	0.600	51.5	0.600	50.9	0.600	51.5	0.600	50.9	0.600
	10	56.0	1.000	372.0	1.000	—	—	—	—	33.6	0.600	260.0	0.698	33.7	0.600	267.5	0.718	33.6	0.600	272.0	1.000
	11	266.1	1.000	58.9	1.000	—	—	—	—	260.0	0.976	35.4	0.600	226.5	0.850	35.4	0.600	168.0	0.631	35.4	0.600
	12	22.4	1.000	127.1	1.000	—	—	—	—	13.5	0.600	83.3	0.656	13.5	0.600	114.5	0.900	13.5	0.600	127.1	1.000
	13	22.4	1.000	127.1	1.000	—	—	—	—	13.5	0.600	83.3	0.656	13.5	0.600	114.5	0.900	13.5	0.600	127.1	1.000

cedures will not be reproduced here, as they have been extensively described elsewhere [9].

The factored elastic moment envelopes for all six examples, which constitute the theoretical USD solution, are given in Fig. 2 in k-ft. units.

Design solutions based on USD, BLD, SLD, LRD, FRD and OLD are summarized in terms of plastic moments M_{pj} required at each critical section in table 2 for the beam examples 1 and 4, in table 3 for the braced frame examples 2 and 5, and in table 4 for the unbraced frame examples 3 and 6.

For the sake of undistorted comparison, the theoretical moments, as resulting from analysis, are generally assumed as design moments. A 5% overdesign of span moments has been used in SLD as an additional ultimate safety and to avoid collapse mechanism formation at the ultimate load.

The BLD method has been applied only to the first two examples, as it appears to require considerable computational effort. It is believed that the solutions obtained for these two examples and the criteria on which the method is based are sufficient to indicate probable trends in its general application.

Safety

An accurate evaluation of the actual carrying capacity of a given design is not possible. If plastic collapse is assumed to be an acceptable failure condition for all designs, the mechanism collapse load W_u^+ and the ultimate safety parameter $u_i = \lambda_i^+ / \lambda_0$ provide a convenient measure of the relative safety of various designs.

Possible collapse modes of the six structures chosen as examples are shown in Fig. 3. For examples 3 and 6 only the most critical mechanisms, i. e., those resulting in lowest safety, are indicated. Values of the ultimate safety parameters u_i for each critical collapse mode and for each design solution are given in table 5.

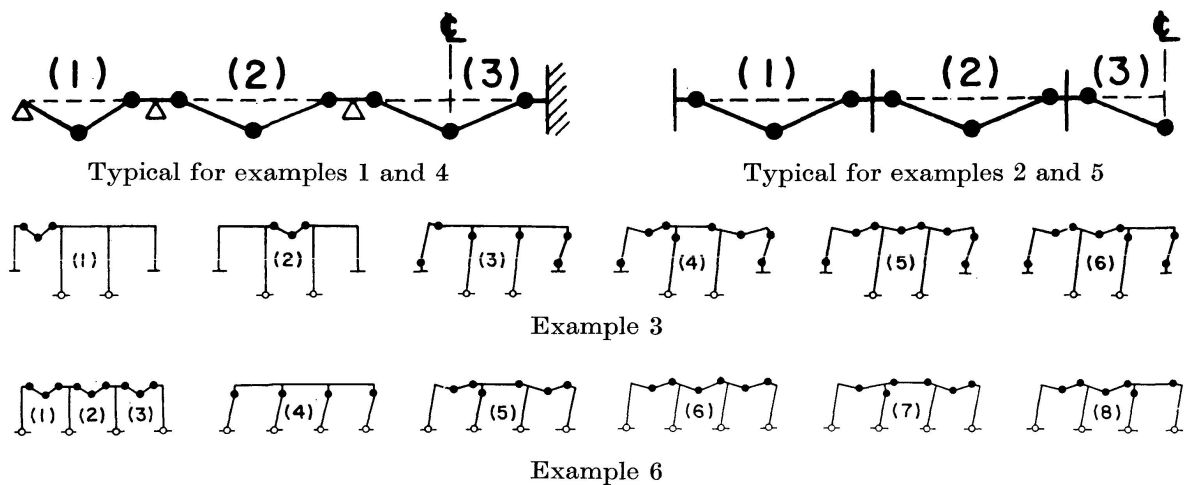

Fig. 3. Collapse modes of example structures.

Table 5. Collapse Safety: u_i Values

Exam- ple	Mecha- nism (i)	USD	BLD	SLD	LRD	FRD	OLD
1	1	1.381	1.269	1.029	1.205	1.000	1.000
	2	1.170	1.042	1.025	1.000	1.000	1.000
	3	1.164	1.063	1.022	1.000	1.000	1.000
2	1	1.095	—	1.028	1.000	1.000	1.000
	2	1.100	—	1.022	1.008	1.000	1.000
	3	1.122	—	1.022	1.028	1.000	1.000
3	1	1.285	1.150	1.052	1.028	—	1.075
	2	1.292	1.116	1.045	1.055	—	1.000
	3	1.975	1.810	1.618	1.542	—	1.396
	4	1.170	1.130	1.030	1.000	—	1.020
	5	1.160	1.100	1.012	1.000	—	1.000
	6	1.170	1.118	1.025	1.000	—	1.000
4	1	1.189	—	1.035	1.000	1.000	1.000
	2	1.389	—	1.022	1.121	1.000	1.000
	3	1.405	—	1.023	1.143	1.000	1.000
5	1	1.116	—	1.029	1.000	1.000	1.000
	2	1.240	—	1.021	1.112	1.000	1.000
	3	1.247	—	1.023	1.118	1.000	1.000
6	1	1.235	—	1.034	1.000	—	1.000
	2	1.387	—	1.054	1.003	—	1.000
	3	1.235	—	1.034	1.000	—	1.000
	4	4.060	—	2.520	2.950	—	3.000
	5	1.241	—	1.018	1.000	—	1.000
	6	1.258	—	1.004	1.000	—	1.050
	7	1.273	—	1.056	1.002	—	1.019
	8	1.325	—	1.020	1.031	—	1.110

It is noted that since the mechanism collapse is the most severe failure criterion considered $u_i = 1$ in methods based on such criterion, i. e., OLD, FRD and LRD, and $u_i > 1$ in SLD, BRD and USD, which adopt more conservative failure criteria. In the full redistribution design (FRD) $u_i = 1$ or $\lambda_i = \lambda_0$ is postulated for a number of collapse modes equal to the number of independent limit equilibrium equations that can be written for the structure. For the optimal limit design (OLD) the same result is obtained, although this condition is not an explicit design requirement. In limited redistribution design (LRD) the condition $u_i = 1$ in at least one collapse mode is imposed and is reflected in table 5. SLD solutions are in general close to those for LRD and for beam problems may be made close to FRD solutions if adequate safety and serviceability criteria are adopted [9], [10].

Safe SLD solutions may be obtained only when all possible loading combinations are considered. This is essential in cases where lateral loads are significant, as the exclusive consideration of the full loading for the structure may be unsafe in some particular loading schemes. The same aspect should be retained in calculating inelastic rotations and checking the compatibility

requirements for all critical sections under the most critical loading arrangements.

BLD solutions result in larger collapse safety than other limit design methods because the governing failure criterion is the crushing of the first, most stressed, section in the structure.

It is seen from table 1 that the largest strength reserves against plastic collapse are provided by the USD solutions, which imply that the structure fails when at least one of its critical section yields.

Serviceability

Normal service performance requires that deflections be within acceptable limits, cracking not be excessive, maximum stresses remain within allowable bounds and inelastic behaviour be avoided. It has been shown [17] that except for the deflection requirement all service conditions are controlled by adopting a sufficiently large margin of safety against the ultimate moment of critical sections. For the under-reinforced sections currently used in reinforced concrete design yielding of steel governs the formation of plastic hinges and the ultimate moment. Hence, the concept of yield safety is introduced, which can be measured by the yield load factor λ_{1j} for each critical section j . By definition, this is the ratio of the ultimate moment to the working moment, i. e., $\lambda_{1j} = M_{pj}/M_j$. Note that, for proportional loading between service and ultimate stages, this ratio also equals the ratio of corresponding first yield to service loads, or $\lambda_{1j} = M_{pj}/M_j = W_{1j}/W$ [7].

It has been shown [9] that adoption of a lower bound for λ_{1j} may ensure the simultaneous satisfaction of all serviceability requirements but the deflection control, and accordingly a tentative bound was suggested as $\lambda_1 = \min \lambda_{1j} = 1.2$.

It is emphasized that further study is necessary for a proper assessment of the minimum values of acceptable yield load factors. Indeed, variable λ_1 values may be warranted to allow for different roles of span, support or column sections or to accommodate different serviceability requirements.

With $\lambda_1 = 1.2$ and λ_0 corresponding to the dead and live loads in each example, minimum values of yield safety parameters, $\min x_j = 1.2/\lambda_0$, resulted as in table 6.

Table 6. Minimum Allowed Yield Safety Parameters for $\lambda_1 = 1.2$

Example	1	2	3	4	5	6
λ_0	1.685	1.700	1.700	1.714	1.700	2.000
$\min x_j$	0.712*)	0.706	0.706*)	0.700	0.706	0.600

*) In BLD, since $\lambda_1 = 1.39$ is adopted, $\min x_j$ for examples 1 and 3 are 0.825 and 0.818 respectively.

For the design solutions listed in tables 2, 3, and 4, it is seen that this serviceability requirement is nowhere violated. Values of $x_j=1$ in the USD solution reflect the criterion of structural failure associated with the first section becoming a plastic hinge, i. e., $\lambda_{1j}=\lambda_0$. Occasional values of $x_j>1$ refer to highly conservative designs for column sections, indicating that in no loading arrangement such sections could be the first to yield.

It is seen that extreme values of x_j are used for SLD solutions, particularly for the beam and braced frame examples. This corresponds to the trend of this paper to put each method to its advantage, ensuring maximum redistribution permitted by the standard serviceability requirements adopted.

In this regard it should be mentioned that example 6 is identical with the frame example used in the Institution of Civil Engineers Research Committee Report [18]. In the absence of guidelines on permissible redistribution and serviceability the SLD solution proposed in the report [18] violates drastically the serviceability requirements for the column sections.

Values of x_j in LRD solutions reflect the alternative criteria specific to the method: either equal yield safety for all critical sections or equal x_j for span sections and smaller, but also equal x_j values for support sections. The criterion of equal minimum yield safety for the largest possible number of critical sections is reflected by the FRD solutions [6].

Consistent with the design objective of minimizing the steel volume the yield safety parameters in OLD solutions tend to be at their lowest permissible values wherever possible.

Efficiency

The efficiency index v_k for various solutions is calculated on the following assumptions:

1. Section sizes remain the same in each example.
2. The flexural steel required at each section is proportional to the corresponding design plastic moment, and
3. the arrangement of the flexural reinforcement follows the typical schemes in Fig. 4.

The efficiency indices calculated with the formula

$$v_k = \frac{v_k}{V_e} = \frac{\sum_j x_j \lambda_0 M_j l_j}{\sum_j \lambda_0 M_j l_j}$$

for the examples and methods discussed are listed in table 7. In general, it is seen that with USD solutions taken as reference, v_k values decrease (i. e. the relative reductions in steel consumption are larger) as BLD, SLD, LRD, FRD and OLD solutions are considered in turn.

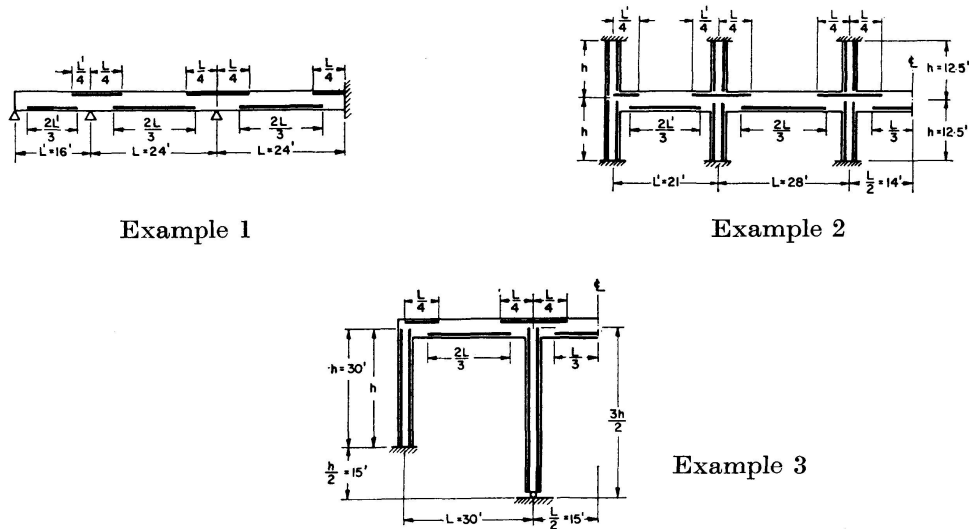

Fig. 4. Typical reinforcement of example structures for the 6 examples.

Table 7. Structural Efficiency: v_k Values

Example	USD	BLD	SLD	LRD	FRD	OLD
1	1.000	0.907	0.877	0.868	0.850	0.825
2	1.000	—	0.948	0.927	0.922	0.890
3	1.000	0.926	0.934	0.790	—	0.760
4	1.000	—	0.793	0.831	0.768	0.766
5	1.000	—	0.897	0.909	0.866	0.829
6	1.000	—	0.772	0.757	—	0.756

It is noted that for the six examples presented in the paper, limit design resulted in steel savings of from 5.2% to 25% in relation to USD.

For all the examples and limit design methods considered (excluding the extreme USD and OLD solutions) an average efficiency index $v=0.852$ is obtained, which represents a steel saving of about 15% compared to the current design practice. It may be concluded that savings of 15–20% vs. USD may be expected by adopting limit design methods for the classes of structures investigated in this paper.

Conclusions

1. When compatibility considerations are not critical, the three basic criteria governing a design solution are: safety, serviceability and efficiency.

2. The parameters $u_i = \lambda_i^+ / \lambda_0$, $x_j = M_{pj} / M_j \lambda_0 = \lambda_{1j} / \lambda_0$ and $v_k = V_k / V_e$ are introduced in the paper for a quantitative evaluation of design solutions in relation to the above criteria.

3. Safety and efficiency are conflicting requirements, related to the amount of allowable moment redistribution: structures designed to accommodate a large

redistribution are less safe, but more efficient than those designed for small moment redistribution.

4. Various limit design methods are available for taking advantage to any desirable degree of the inelastic moment redistribution in reinforced concrete structures. Limit design methods illustrated in the examples range in the following descending order in relation to their ultimate safety: USD, BLD, SLD, LRD, FRD and OLD, with the USD and OLD having the largest and smallest reserve strength against plastic collapse respectively. The above order is preserved for the efficiency index, indicating an increase of steel savings vs. USD as one moves from BLD towards OLD.

5. Adoption of a minimum yield load factor λ_1 is a convenient and reliable approach to the control of serviceability requirements in any limit design method.

6. The examples presented in this paper indicate that steel savings of about 15% vs. USD are very likely to be obtained, regardless of the limit design method adopted.

7. Because of the small difference in efficiency of FRD and OLD solutions, it appears that full redistribution should be a practical aim in design, which would ensure results not too far from those based on mathematical optimization.

Notation

i	subscript referring to collapse modes (mechanism i)
j	subscript referring to critical sections
k	subscript referring to particular solutions obtained by using various limit design methods
l_j	conventional length over which the reinforcement of section j is maintained constant
M_j	elastic envelope moment value at critical section j
M_{pj}	design plastic moment at initial section $j \equiv$ ultimate moment load based on U.S.D.
$u_i = \lambda_i^\dagger / \lambda_0$	ultimate safety parameter
$v_k = V_k / V_e$	efficiency index
V_e	flexural steel volume in the elastic, U.S.D. solutions
V_k	flexural steel volume in a particular design solution
W	working load
W_u	ultimate load
W_{1j}	first yield load when section j is first to become a plastic hinge
$x_j = M_{pj} / \lambda_0 M_j = \lambda_{1j} / \lambda_0$	yield safety parameter for section j
$\lambda_0 = W_u / W$	overall load factor of the structure
λ_i^\dagger	collapse load factor of a structure associated with mechanism i
$\lambda_{1j} = W_{1j} / W$	yield load factor of section j

$\lambda_1 (= 1.2)$	minimum allowable value of the yield load factor
θ_j	inelastic rotation of plastic hinge j
θ_{pj}	rotation capacity of plastic hinge j
USD	ultimate strength design
BLD	bi-linear design
SLD	simplified limit design
LRD	limited redistribution design
FRD	full redistribution design
OLD	optimum limit design

Acknowledgements

This paper is part of an extensive investigation on the Inelastic Behaviour of Reinforced Concrete Structures, in progress at the University of Waterloo, Waterloo, Ontario, which is financially supported by the National Research Council of Canada, under Grant no. A-4789.

References

1. ACI 318-63: Building Code Requirements for Reinforced Concrete. American Concrete Institute Publications, June 1963.
2. H. A. SAWYER, Jr.: Design of concrete frames for two failures stages. Proceedings, International Symposium on Flexural Mechanics of Reinforced Concrete, Miami, Florida, Nov., 1964, ACI Special Publication, SP-12, p. 7-28.
3. H. A. SAWYER, Jr.: Comprehensive design of reinforced concrete frames by plasticity factors. Bulletin d'Information CEB, No. 53, Jan. 1966, p. 299-316.
4. A. L. L. BAKER: Ultimate load theory applied to the design of reinforced concrete and prestressed concrete frames. Concrete Series, London, 1956.
5. A. L. L. BAKER: Ultimate load design of reinforced concrete frames. A recapitulation and appraisal. March, 1963. Publications IABSE, V. 23, 1963, p. 23-56.
6. M. Z. COHN: Optimum limit design for reinforced concrete continuous beams. Proceedings ICE, V. 30, April, 1965, p. 675-707.
7. M. Z. COHN: Limit design solutions for concrete structures. Proceedings ASCE, Journal Structural Division, V. 93, No. ST 1, Feb. 1967, p. 37-58.
8. M. Z. COHN: Limit design of reinforced concrete frames. Proceedings ASCE, Journal Structural Division, V. 94, No. ST 10, Oct. 1968, p.
9. M. Z. COHN, E. F. BURNETT, O. DUTT, R. FRANCIS, D. E. GRIERSON, H. C. PARAMESWAR and S. TALWAR: Example of limit design for reinforced concrete building structures. Colloquium on Limit Design for Structural Concrete, Univ. of Waterloo, Waterloo, Ontario, Sept. 1967, 132 p.
10. E. F. BURNETT and M. Z. COHN: Modifications to Professor Baker's Simplified Limit Design Method (to be published).
11. M. Z. COHN and D. E. GRIERSON: Optimal design of reinforced concrete beams and frames. Final Publication, 8th IABSE Congress, New York, Sept. 1968.
12. D. E. GRIERSON: Optimal design of reinforced concrete frames. Ph. D. Thesis, Univ. of Waterloo, Waterloo, Ontario, Sept. 1968.

13. H. C. PARAMESWAR: Some contributions to the problem of compatibility in limit design of concrete structures. Ph. D. Thesis, Univ. of Waterloo, Waterloo, Ontario, July, 1968.
14. M. Z. COHN and D. E. GRIERSON: An automatic approach to the analysis of plastic frames under fixed and variable loading. Paper presented at the ASCE National Meeting on Structural Engineering, Pittsburgh, Pa., Sept. 1968.
15. G. MACCHI: A proposal of analysis based on the theory of imposed rotations. Bulletin d'Information CEB, No. 21, Jan. 1960, p. 121-158.
16. M. Z. COHN: Rotation compatibility in the limit design of reinforced concrete continuous beams. Proceedings, International Symposium on Flexural Mechanics of Reinforced Concrete, Miami, Florida, 1964, ACI Special Publication SP-12, p. 359-382.
17. M. Z. COHN: On the optimum limit design method. Report to the Joint ASCE-ACI Committee 428, Limit Design, February, 1966 (unpublished).
18. ICE Research Committee: Ultimate load design of concrete structures. Proceedings ICE, V. 21, Feb. 1962, p. 339-442.

Summary

Safety, serviceability and efficiency of solutions based on various limit design methods, as applied to some typical reinforced concrete building structures, are compared.

Safety is considered in relation to the failure of structures as collapse mechanisms. Serviceability is evaluated in terms of the safety against first yield of critical sections. Structural efficiency for each limit design method is evaluated by the ratio of flexural steel consumption to that resulting from an elastic design.

Six examples of typical building structures (two continuous beams, two multi-storey, multi-bay braced frames and two single-storey, unbraced frames) illustrate the relevant features of solutions based on existing limit design methods.

Résumé

Une comparaison de ces trois facteurs est faite pour différentes méthodes de dimensionnement à la rupture, appliquées à quelques structures typiques en béton armé.

La sécurité de rupture se rapporte au moment de ruine par formation de mécanisme instable. La sécurité de service se rapporte à la plastification des premières sections critiques. Le rendement pour chaque méthode se mesure au tonnage de fer d'armature employé par rapport au dimensionnement élastique.

Six exemples typiques de structures (deux poutres continues, deux portiques à plusieurs étages renforcés, et deux portiques simples, non-renforcés) montrent les caractéristiques essentielles des solutions des diverses méthodes existantes de dimensionnement à la rupture.

Zusammenfassung

Sicherheit, Nutzbarkeit und Leistung von Berechnungen, die auf verschiedenen Traglastkriterien fußen, werden an einigen typischen Stahlbetonbauten miteinander verglichen.

Die Sicherheit bezieht sich dabei auf das Bruchmoment durch Bildung eines instabilen Mechanismus. Die Nutzbarkeit bedeutet die Sicherheit vor dem Nachgeben der ersten kritischen Querschnitte. Die Leistung mißt sich am Verbrauch an Armierungsstahl für die verschiedenen Methoden gegenüber einer elastischen Bemessung.

Sechs typische Beispiele (2 Durchlaufträger, zwei versteifte Stockwerkrahmen und zwei einfache, unversteifte Rahmen) zeigen die wichtigen Charakteristiken der verschiedenen existierenden Bruchbemessungsmethoden.