

# Static and stability of thin walled beams

Autor(en): **Giangreco, E.**

Objekttyp: **Article**

Zeitschrift: **IABSE publications = Mémoires AIPC = IVBH Abhandlungen**

Band (Jahr): **26 (1966)**

PDF erstellt am: **25.09.2024**

Persistenter Link: <https://doi.org/10.5169/seals-20871>

## **Nutzungsbedingungen**

Die ETH-Bibliothek ist Anbieterin der digitalisierten Zeitschriften. Sie besitzt keine Urheberrechte an den Inhalten der Zeitschriften. Die Rechte liegen in der Regel bei den Herausgebern.

Die auf der Plattform e-periodica veröffentlichten Dokumente stehen für nicht-kommerzielle Zwecke in Lehre und Forschung sowie für die private Nutzung frei zur Verfügung. Einzelne Dateien oder Ausdrucke aus diesem Angebot können zusammen mit diesen Nutzungsbedingungen und den korrekten Herkunftsbezeichnungen weitergegeben werden.

Das Veröffentlichen von Bildern in Print- und Online-Publikationen ist nur mit vorheriger Genehmigung der Rechteinhaber erlaubt. Die systematische Speicherung von Teilen des elektronischen Angebots auf anderen Servern bedarf ebenfalls des schriftlichen Einverständnisses der Rechteinhaber.

## **Haftungsausschluss**

Alle Angaben erfolgen ohne Gewähr für Vollständigkeit oder Richtigkeit. Es wird keine Haftung übernommen für Schäden durch die Verwendung von Informationen aus diesem Online-Angebot oder durch das Fehlen von Informationen. Dies gilt auch für Inhalte Dritter, die über dieses Angebot zugänglich sind.

# Static and Stability of Thin Walled Beams \*)

*Statique et stabilité des poutres à parois minces*

*Statisches Verhalten und Stabilität dünnwandiger Träger*

E. GIANGRECO

Italy

## 1. Historical Introduction

The need of modifying the results obtained through the technical theory of full solid section for the study of non uniform twisting of thin walled beams was realized for the first time by TIMOSHENKO in a study of 1905 concerning the double T section beam [1]. After this study, many researches [2], [3], [4], [5], were conducted with the purpose of clarifying the static behaviour as well as the possible instability phenomena due to external general forces. The need of applying the results of non uniform twisting theory, obtained by TIMOSHENKO for the case of double T section, to the thin walled sections having general and, particularly, open shape, was felt at the beginning, especially in the field of aeronautic constructions when, in the years 1930—1935, thin section beams started to be used and, in the meantime, the shell structures technique started to develop. As far as open section beams are concerned, such studies were systematically formulated in the works performed by VLASOV [8], [22], and TIMOSHENKO [6], which brought to the formulation of sectorial areas theory.

The discussion on the same problem was still open as far as the statics of close multiconnected thin sections was concerned; this problem was dealt with by VLASOV for the case of close sections having polygonal directrix, and by KARMAN and CRISTENSEN for the general case [12].

---

\*) The results presented in this paper were obtained in the course of research sponsored by the Consiglio Nazionale delle Ricerche and the European Office of Aerospace Research under Contract AF 61 (052)–813.

All above mentioned studies tacitly admitted the cross sections warping to be present only in case of non uniform twist, and furthermore, such warping to be the only effect caused by the primary flow of tangential stresses associated with the rate of twisting moment absorbed in accordance with the classic law of beam theory. The approximations connected with the basic hypothesis of sectorial areas had to be found.

A study [13] on this subject was conducted by KARMAN and WEI-ZANG-CHIEN. These authors, limitedly to the case of non uniform twist of thin walled beams having cellular sections, removed the approximation tied up with the admission that warping was the only effect caused by the primary flow of tangential stresses. CICALA had formerly studied [14], [15], [16], [17], [18], [19], [20] this problem with specific reference to the application in the aeronautical field and reached more general and detailed conclusions. The results obtained by all these studies revealed the presence of exasperated local strains, different from those previously obtained by study [12]. It was therefore necessary to remove all basic approximations, keeping as only hypothesis the cross section indeformability, and to consider at the same time the case of open and close sections.

This problem has been studied at the Institute of Structural Engineering of Naples University and it seems to us that a complete answer was recently given by CAPURSO [23], [24], [25], [26], [27], who dealt in general with the problem of static calculation of thin walled beams having a general section, taking into account all warping effects of the cross section caused by twisting as well as by shearing and dislocations. This study confirmed the adequacy of sectorial areas theory to represent the stress and twist state within the open section of the beam subject to general external forces, with the exception of the areas close to bounds or to points of application of concentrated forces, where remarkably exasperated local stresses were noticed, which could not be calculated through the above mentioned approximated theory.

It can be said now that through the sectorial areas theory we can study the open section thin walled beams as well as we can study the full section or close thin section beams through the common beam theory.

At the same time the theory of thin walled beam stability was developing, which was of great interest when the first applications were made in the field of aeronautic structures. On this subject the first experiments furnished the result, astonishing at that time, that the critical load of a section subject to axial stress was remarkably lower than Eulero's critical load. This always occurred whenever the section centroid did not coincide with the centre of torsion, while the critical load appeared to coincide with the critical load of Eulero's formula; and also occurred in the obvious case when the centroid and the centre of torsion of the section were the same, being the section subject to axial stress eccentric in regard to the centroid, and applied to the centre of torsion. In case of short sections, the experiments revealed, for a section

having two symmetry axes, a phenomenon of instability only due to torsion which was later called "Wagner's effect".

Above mentioned studies performed by VLASOV and TIMOSHENKO gave a first set up of the problem of stability, with particular reference to the basic cases of instability of the section subject to axial and transversal stresses.

However, a systematic arrangement of the problem of stability was still necessary, in order to study all the phenomena concerned with such problem, including the important aspect of coaction states. A general set up has been furnished at the Institute of Structural Engineering of Naples University with the studies recently conducted by COMO [28], [29], [30], [31], [32], [33], who gave a complete formulation of the problem as far as instability due to external forces, as well as to dislocations is concerned.

This study, geometrically conducted through an adequate systematic procedure, permitted to formulate the differential equations system governing all the phenomena of instability of thin walled beams subject to forces and dislocations.

New unstabilizing effects of external forces are determined, which are most important when the shearing forces are both present at the same time and furthermore, the unstable equilibria due to twisting actions are evidenced with specific reference to dislocations caused by thermal and mechanical actions (as prestressing).

Such researches on statics and stability of thin walled beams [36] represent an important set up of the problem, which can lead to interesting experiments as well as to important applications for modern technical problems<sup>1)</sup>. Herebelow the static theory, through the above mentioned rigorous formulation, and then the stability theory, in case of general loading conditions and distortions, will be discussed.

## 2. The Static Theory

### 2.1. The Law of Warping of Cross Section in Case of Uniform Twist

We consider a body having uniform walls (fig. 1), and we denote:

$$\theta = \frac{d\varphi_0}{dz} \tag{1}$$

---

<sup>1)</sup> Among the most interesting applications we want to point out those concerning the static calculation of shell structures, which are of great importance in the field of aeronautic constructions, those concerning problems of stability of thin walled beams when prestressing and residual stresses are present, and, furthermore, those concerning problems of dynamic stability. For this latter case, it must be noticed that the problem of dynamic stability due to flexio-torsional buckling of a cantilever subject to a transversal follower force, for which the solution is furnished in this paper, can be an interesting starting point for the study of stability of wings supporting jet engines; on this subject experiments are under way at the North-Western University of Evanston, Ill.

the value of unitary rotation of torsion along the beam axis; the law of warping of the mid fiber of the cross section of the beam can be obtained from the following relation:

$$\gamma = \frac{\partial w}{\partial s} + \frac{\partial \eta}{\partial z} = \frac{\tau}{G}, \quad (2)$$

being  $w$  the displacement along  $z$  of a point  $P$  located on the mid fiber of the wall,  $\eta$  the displacement along the tangent to  $s$ , and  $\tau$  the value of the tan-

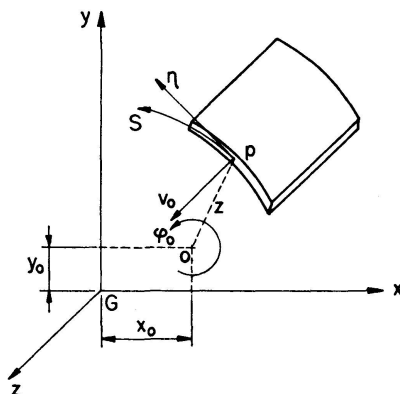

Fig. 1.

gential stress on the mid fiber. Since the motion along its plane of the cross section of the beam is characterized by a rotation around a general point  $0 \equiv (x_0, y_0)$ , the tangential displacement  $\eta$  is:

$$\eta = r \varphi_0, \quad (3)$$

being  $r$  the distance between  $0$  and the tangent to  $s$  at  $P$ .

In view of (1), relation (2) can be written as follows:

$$\frac{\partial w}{\partial s} + r \theta = \frac{\tau}{G}. \quad (4)$$

By calculating  $\tau$  as function of  $\theta$ , above relation (4) determines the warping law of the cross section of the beam for open as well as for close section beams.

In the first case, in correspondence with the mid fiber, we have:

$$\tau = 0 \quad (5)$$

and, from (4), we obtain:

$$w = -\theta \omega_z(s), \quad (6)$$

where we denoted:

$$\omega_z(s) = \int_0^s r ds + C \quad (7)$$

the sectorial coordinate of point  $P$ , obviously determined less the arbitrary constant  $C$ .

In case of close sections, the tangential stress  $\tau$  on the mid fiber can be expressed as follows:

$$\tau = G \frac{f}{t} \theta, \quad (8)$$

being  $f$  the flow's constant, and  $t$  the thickness of the wall.

Therefore, relation (4) gives:

$$w = -\theta \omega_z(s), \quad (9)$$

being:

$$\omega_z(s) = \int_0^s \left( r - \frac{f}{t} \right) ds + C \quad (10)$$

the general sectorial coordinate of point  $P$ .

If we choose constant  $C$  such as to annul the average value of sectorial coordinate  $\omega_z$ , and we consider the centre of rotation 0 as shear or twist centre of the cross section, the sectorial coordinate  $\omega_z$  has the well known characteristics:

$$\int_A \omega_z dA = \int_A \omega_z x dA = \int_A \omega_z y dA = 0. \quad (11)$$

Such characteristics, which are not essential in case of uniform twist, limit the motion of the cross section of the beam around the shear centre, in case of non uniform torsion.

## 2.2. The Case of Non Uniform Torsion in Accordance with Sectorial Areas Theory

The results previously obtained concern the case where  $\theta$  does not depend on  $z$ . On the contrary, if  $\theta$  depends on  $z$ , it can be assumed with approximation that the cross section warping can be calculated through equation (6), being  $\theta = \theta(z)$  the local value of twist rate  $\varphi_0$ . Such approximation will be more exact as the function  $\theta = \theta(z)$  is closer to a constant.

In view of the above, being:

$$w(z, s) = -\theta(z) \omega_z(s) \quad (12)$$

some axial strains of the fibers will occur in the wall:

$$\epsilon_z = \frac{\partial w}{\partial z} = -\frac{d\theta}{dz} \omega_z(s). \quad (13)$$

Taking into consideration that, because of the hypothesis of transversal indeformability of the section, we have:

$$\epsilon_s = 0. \quad (14)$$

To above strains, following stresses will be associated:

$$\sigma_z = \frac{E}{1-\nu^2} \epsilon_z = -\frac{E}{1-\nu^2} \frac{d\theta}{dz} \omega_z(s). \quad (15)$$

It is therefore essential for function  $\omega_z$  to satisfy (11) for the necessary equilibrium conditions of displacement along  $z$  and of rotation around axes  $x$  and  $y$ .

For the point by point equilibrium of displacement along  $z$  following equation must be satisfied:

$$\frac{\partial \sigma_z}{\partial z} + \frac{\partial \tau_{zs}}{\partial s} = 0 \quad (16)$$

with the assumption of constant thickness.

From (16), making use of (15), we obtain for the secondary flow of tangential stresses:

$$\tau_{zs} = \frac{E}{1-\nu^2} \frac{d^2 \theta}{dz^2} \left\{ \int_0^s \omega_z ds + C \right\}, \quad (17)$$

where the arbitrary constant  $C$  can be determined in case of absence of  $\tau_{zs}$  on one extreme edge for open sections, and in case of cyclic behaviour for close sections.

Equation (17) can also be written as follows:

$$\tau_{zs} = \frac{E}{1-\nu^2} \frac{d^2 \theta}{dz^2} \frac{S_\omega}{t}, \quad (18)$$

being:

$$S_\omega = t \left\{ \int_0^s \omega_z ds + C \right\}. \quad (19)$$

The resultant of tangential stresses distribution (18) is a torque having value:

$$H_\omega = \frac{E I_\omega}{1-\nu^2} \frac{d^2 \theta}{dz^2}, \quad (20)$$

where:

$$I_\omega = \int_A \omega_z^2 dA. \quad (21)$$

By adding the twisting reactions of primary and secondary flows, the fundamental equation of the beam twist becomes:

$$\frac{E I_\omega}{1-\nu^2} \frac{d^2 \theta}{dz^2} - \frac{G I_p}{q} \theta = M_t(z), \quad (22)$$

being  $M_t(z)$  the twisting moment characteristic variable along  $z$ .

In this manner, we can imagine the two characteristics: twisting moment  $M(z)$  and bimoment  $B(z)$ , represented by the self-balanced distribution of normal stresses (15), to act in the cross section of the beam.

In fact, the normal stresses (15) can be written as follows:

$$\sigma_z = \frac{B(z)}{I_\omega} \omega_z(s), \quad (23)$$

being:

$$B(z) = \int_A \sigma_z \omega_z dA = - \frac{E I_\omega}{1-\nu^2} \frac{d\theta}{dz}. \quad (24)$$

Equation (22) calculated in regard to  $z$ , and denoting:

$$m(z) = -\frac{dM_t}{dz} \tag{25}$$

the distribution of external torques, can also be expressed as follows:

$$\frac{d^2 B}{dz^2} - \alpha^2 B = m(z), \tag{26}$$

where:

$$\alpha^2 = \frac{1 - \nu^2}{q} \frac{G I_p}{E I_\omega}. \tag{27}$$

The homogeneous equation:

$$\frac{d^2 B}{dz^2} - \alpha^2 B = 0 \tag{28}$$

associated with the boundary conditions:

$$\begin{aligned} B(0) &= \int_A p_{0z}(s) \omega_z dA, \\ B(l) &= \int_A p_{lz}(s) \omega_z dA \end{aligned} \tag{29}$$

and being  $p_{0z}$  and  $p_{lz}$  distributions of axial forces on the extreme bases of the beam, expresses the penetration within the structure of actions caused by self-balanced forces applied on the extreme bases. The penetration capacity is strictly tied up with the value of coefficient (27) and is higher as smaller is  $\alpha^2$ .

Therefore, keeping in mind the difference of classic torsional rigidity between the open section and the close section beams, it appears clear that in the first case the bimoment penetration is deep and affects, in most cases, the whole development of the body, while in the second case such penetration is very limited and has only a local effect (fig. 2).

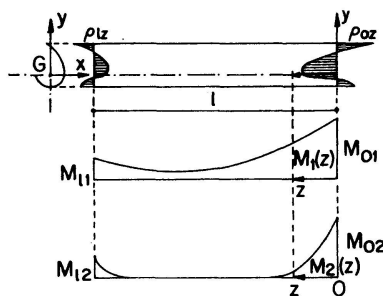

Fig. 2.

In each section of the beam the twisting characteristic has no value; therefore the twisting moment absorbed through the traditional procedure and corresponding to the primary flow, and the twisting moment corresponding to the secondary flow will be balanced.

In case of open thin section beam the traditional rigidity, always very low:

$$C = \frac{G I_p}{q} \tag{30}$$



opposes the primary flow, while the sectorial rigidity:

$$C_{\omega} = \frac{E I_{\omega}}{1 - \nu^2} \quad (31)$$

much higher than the traditional rigidity, opposes the secondary flow. Therefore, in case of open section the warping due to the primary flow will be much higher than the neglected warping due to secondary flow.

Quite different is the case of close sections where the two rigidities  $C$  and  $C_{\omega}$  have the same value and therefore the secondary warping can be even more remarkable than the primary warping.

Therefore, in view of the above considerations, we can conclude saying that in case of open section beams the sectorial areas theory represents adequately the local behaviour.

Above results however, cannot be considered exact in case of close sections.

Following paragraphs will clarify such considerations through a strict theory.

### 2.3. *The Strict Theory of Thin Walled Beams*

For a rigorous set up of the problem, two hypotheses have to be removed:

1. The warping of the cross section of the beam depending exclusively on the primary flow of tangential stresses.
2. Such phenomenon occurring only in case of uniform torsion.

Therefore, in the cross section we will consider present at the same time the two shearing forces and the torque:

$$\begin{aligned} T_x &= T_x(z), \\ T_y &= T_y(z), \\ M_z &= M_z(z), \end{aligned} \quad (32)$$

coinciding respectively with the two shear stresses along the main inertia axes of the section and with the twisting moment calculated in regard to the axis of the shear centre, and furthermore the three transversal components of a general dislocation:

$$\begin{aligned} \vartheta_x &= \vartheta_x(z), \\ \vartheta_y &= \vartheta_y(z), \\ \vartheta_z &= \vartheta_z(z), \end{aligned} \quad (33)$$

coincident respectively with the two displacements along the main inertia axes  $x$  and  $y$  and with a torsion around the shear centre axis 0.

Furthermore, we will imagine a general distribution of surface forces:

$$p_z = p_z(z, s) \quad (34)$$

in correspondence with the mid fiber of the wall and acting in parallel with

the body axis and furthermore, the axial strain dislocation:

$$\epsilon_z^* = \epsilon_z^*(z, s) \tag{35}$$

due, as an example, to a non uniform thermal field.

Only in the hypothesis of transversal indeformability of the beam the motion of the general point of the wall will be characterized by the three transversal displacements:

$$\begin{aligned} u_0 &= u_0(z), \\ v_0 &= v_0(z), \\ \varphi_0 &= \varphi_0(z), \end{aligned} \tag{36}$$

coinciding respectively with the two displacements along axes  $x$  and  $y$  and with the rotation around the shear centres axis, and by the longitudinal component:

$$w = w(z, s), \tag{37}$$

coinciding with the displacement along the axis of the body (fig. 3).

The displacement  $\eta$  along the tangent to the mid fiber becomes:

$$\eta = u_0 \frac{dx}{ds} + v_0 \frac{dy}{ds} + \varphi_0 r. \tag{38}$$

The strains of the mid fiber of the wall will be:

$$\begin{aligned} \epsilon_z &= \frac{\partial w}{\partial z}, \\ \gamma_{zs} &= \frac{\partial w}{\partial s} + \frac{\partial \eta}{\partial z} \end{aligned} \tag{39}$$

and the stress can be associated to these latters through the following relations:

$$\begin{aligned} \sigma_z &= \frac{E}{1-\nu^2} (\epsilon_z - \epsilon_z^*), \\ \tau_{zs} &= G (\gamma_{zs} - \gamma_{zs}^*), \end{aligned} \tag{40}$$

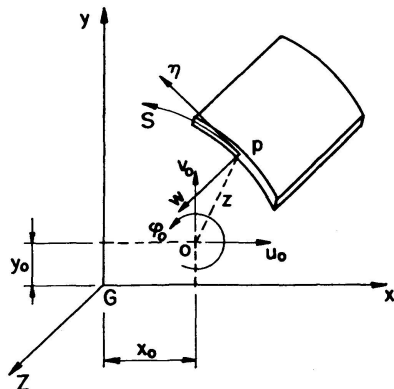

Fig. 3.

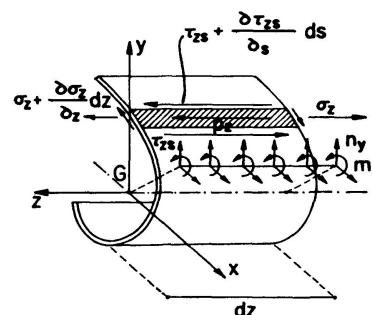

Fig. 4.

being  $\gamma_{zs}^*$  the displacement caused by the transversal components (33) from dislocations:

$$\gamma_{zs}^* = \vartheta_x \frac{dx}{ds} + \vartheta_y \frac{dy}{ds} + \vartheta_z r. \quad (41)$$

Therefore, the stress of the wall can be expressed as follows:

$$\begin{aligned} \sigma_z &= \frac{E}{1-\nu^2} \left[ \frac{\partial w}{\partial z} - \epsilon_z^* \right], \\ \tau_{zs} &= \frac{E}{2(1+\nu)} \left[ \frac{\partial w}{\partial s} + \frac{du_0}{dz} \frac{dx}{ds} + \frac{dv_0}{dz} \frac{dy}{ds} + \frac{d\varphi_0}{dz} r - \gamma_{zs}^* \right]. \end{aligned} \quad (42)$$

The main difference from the above mentioned approximated theory is that in (42)  $\tau_{zs}$  is not only due to the primary flow.

Such hypothesis excepted, in order to formulate the basic equations in unknowns (36) and (37), it is necessary to replace the (42) in the four indefinite equilibrium equations:

$$\begin{aligned} \frac{\partial \sigma_z}{\partial z} + \frac{\partial \tau_{zs}}{\partial s} + \frac{p_z}{t} &= 0, \\ \int_A \tau_{zs} \frac{dx}{ds} dA &= T_x(z), \\ \int_A \tau_{zs} \frac{dy}{ds} dA &= T_y(z), \\ \int_A \tau_{zs} \frac{d\omega_z}{ds} dA + \frac{G I_p}{q} \left( \frac{d\varphi_0}{dz} - \vartheta_z \right) &= M_z(z) \end{aligned} \quad (43)$$

by denoting  $\omega_z$  the torsional warping function already obtained above, and:

$$\frac{G I_p}{q} \frac{d\varphi_0}{dz} \quad (44)$$

the rate of external twisting moment absorbed through the traditional torsional rigidity of the close or open thin beam (fig. 4).

Replacing (42) in (43), after some transformations, we obtain the basic system:

$$\begin{aligned} \frac{2}{1-\nu} \frac{\partial^2 w}{\partial z^2} + \frac{\partial^2 w}{\partial s^2} - \frac{d^2 x}{ds^2} \int_A \frac{\partial w}{\partial s} \frac{dX}{ds} dA - \frac{d^2 y}{ds^2} \int_A \frac{\partial w}{\partial s} \frac{dY}{ds} dA \\ - \frac{d^2 \omega_z}{ds^2} \int_A \frac{\partial w}{\partial s} \frac{d\Omega_z}{ds} dA = -\frac{1}{G} \left( \frac{p_z}{t} + \tau_x \frac{d^2 x}{ds^2} + \tau_y \frac{d^2 y}{ds^2} + \mathfrak{M}_z \frac{d^2 \omega_z}{ds^2} \right) + \frac{2}{1-\nu} \frac{\partial \epsilon_z^*}{\partial z}, \\ \frac{du_0}{dz} = - \int_A \frac{\partial w}{\partial s} \frac{dX}{ds} dA + \frac{T_x(z)}{G} + \vartheta_x(z), \\ \frac{dv_0}{dz} = - \int_A \frac{\partial w}{\partial s} \frac{dY}{ds} dA + \frac{T_y(z)}{G} + \vartheta_y(z), \\ \frac{d\varphi_0}{dz} = - \int_A \frac{\partial w}{\partial s} \frac{d\Omega_z}{ds} dA + \frac{\mathfrak{M}_z(z)}{G} + \vartheta_z(z). \end{aligned} \quad (45)$$

In eqs. (45) the three functions:

$$\begin{aligned} T_x &= \tau_x(z), \\ T_y &= \tau_y(z), \\ \mathfrak{M}_z &= \mathfrak{M}_z(z) \end{aligned} \quad (46)$$

are linearly connected with the values of shearing forces and torque (32), while the three functions:

$$\begin{aligned} X &= X(s), \\ Y &= Y(s), \\ \Omega_z &= \Omega_z(s) \end{aligned} \quad (47)$$

are linearly connected with the functions depending only on the geometry of the cross section:

$$\begin{aligned} x &= x(s), \\ y &= y(s), \\ \omega_z &= \omega_z(s). \end{aligned} \quad (48)$$

Of system (45) is appears fundamental the first equation with the only unknown  $w$  which must of course be associated with the boundary conditions concerning the longitudinal abscissa  $z$  as well as the transversal abscissa  $s$ .

The first ones depend on the constrains and the loads existing on the two extreme bases, the second ones depend on the geometry of the cross section of the beam.

Very interesting is the solution of the homogeneous equation associated with the first equation (45), governing the problem of determination of function  $w$  if the beam is subject only at the two extreme bases to a system of longitudinal forces:

$$p_{0z}(s), \quad p_{lz}(s) \quad (49)$$

variable along  $s$  and acting only in accordance with the total equilibrium conditions of the body (fig. 5).

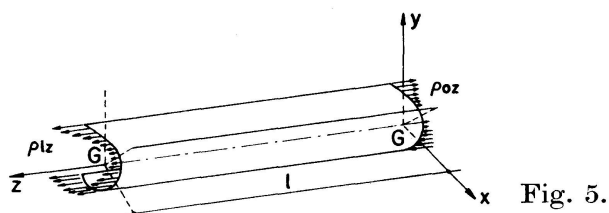

Fig. 5.

In this case the displacement  $w$  can be expressed as follows:

$$w(z, s) = w_z(z) - \varphi_y(z)x(s) + \varphi_x(z)y(s) + \sum_{n=1}^{\infty} \varphi_n(z)\Phi_n(s), \quad (50)$$

being  $w_z(z)$ ,  $\varphi_y(z)$ ,  $\varphi_x(z)$  the amplitude of average displacement  $z$  and of rotations around  $x$  and  $y$  of the cross section of the beam, and being:

$$w'(z, s) = \sum_{n=1}^{\infty} \varphi_n(z) \Phi_n(s) \quad (51)$$

the warping of the cross section. However, this latter can decompose, as it appears from (51), into infinite elementary types of simple warping, of which  $\varphi_n(z)$  represent the amplitude which is governed by the condition:

$$\frac{d^2 \varphi_n}{dz^2} - \alpha_n^2 \varphi_n = 0 \quad (52)$$

and  $\Phi_n = \Phi_n(s)$  represent the shape.

The procedures  $\alpha_n$  are strictly associated with the warping functions  $\Phi_n(s)$  which also have the remarkable properties:

$$\begin{aligned} \int_A \Phi_n dA &= \int_A \Phi_n x dA = \int_A \Phi_n y dA = 0, \\ \int_A \Phi_n \Phi_m dA &= 0, \quad \text{if } n \neq m. \end{aligned} \quad (53)$$

Passing from displacements to stresses and particularly to normal stresses  $\sigma_z(z, s)$  we have, in perfect agreement with (50):

$$\sigma_z = \frac{N_z}{A} - \frac{M_y}{I_y} x(s) + \frac{M_x}{I_x} y(s) + \sum_{n=1}^{\infty} \frac{M_n}{I_n} \Phi_n(s), \quad (54)$$

being the first three terms, traditional of the common beam theory, connected with the resultants of external actions, and being:

$$\sigma'_z = \sum_{n=1}^{\infty} \frac{M_n(z)}{I_n} \Phi_n(s) \quad (55)$$

the part, clearly self-balanced because of (53), of the stresses due to the actual means of application of external loads on the two extreme bases.

This latter part, as it appears in (55), can also be obtained by adding infinite simple parts, every one of which can be connected with a fictitious characteristic  $M_n(z)$  called warping moment, governed by following equation:

$$\frac{d^2 M_n}{dz^2} - \alpha_n^2 M_n = 0 \quad (56)$$

and can be connected with the boundary conditions:

$$\begin{aligned} M_n(0) &= - \int_A p_{0z}(s) \Phi_n(s) dA, \\ M_n(l) &= \int_A p_{lz}(s) \Phi_n(s) dA. \end{aligned} \quad (57)$$

If the beam is quite long, the strains and stresses caused by warping moments  $M_n$  have local characteristics, in fact they can be expressed as follows:

$$\begin{aligned} M_n(z) &= -M_n(0) e^{-\alpha_n z} & \text{for } z \cong 0, \\ M_n(z) &= M_n(l) e^{-\alpha_n(l-z)} & \text{for } z \cong l. \end{aligned} \quad (58)$$

Such solutions are exact in practice if the beam length  $l$  is two times the damping distance  $d_n$  intended as distance between the opposite bases, so that the internal characteristic  $M_n$  becomes for instance  $\frac{1}{1000}$  of the characteristic acting on the opposite bases.

In accordance with (58) such distance becomes:

$$d_n = \frac{6,91}{\alpha_n} \tag{59}$$

and therefore is smaller as higher is the coefficient  $\alpha_n$ . As a result of numerical calculations for beams having different shapes of the cross section [25], it was determined that for open section thin beams having sectorial coordinate  $\omega_z(s)$  having somewhere a value, a first type of elementary warping  $\Phi_1(s)$  occurs approximately coinciding with the sectorial coordinate itself. For such wave the coefficient  $\alpha_1$  appears to be much smaller than the others and therefore the penetration of corresponding warping moment  $M_1(z)$  is very remarkable compared to the penetration of all other characteristics  $M_n(z)$  which are only local ones.

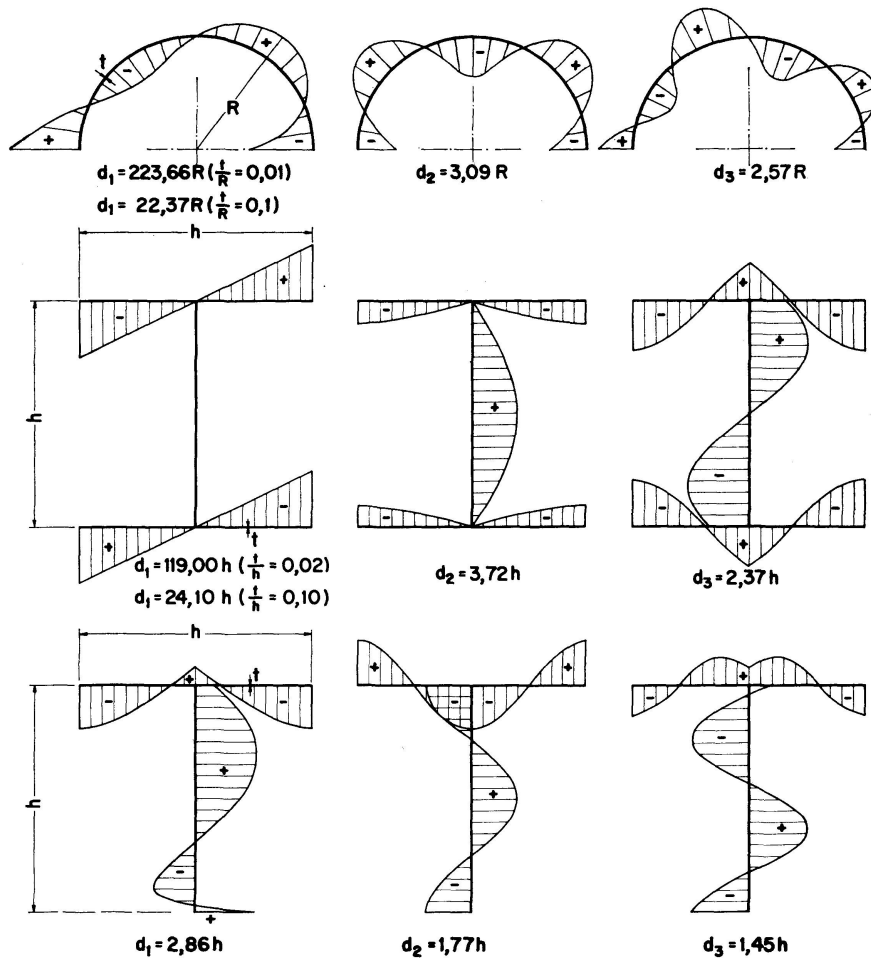

Fig. 6.

For the open sections having sectorial coordinate with no value in any point and for the close sections the maximum penetration wave is of the local type and is not much different, as far as penetration intensity, from the immediately following waves. Fig. 6 shows for the  $C$ ,  $I$ , and  $T$  sections the first three types of simple warping with relative damping distances  $d_n$ .

For the  $C$  and  $I$  sections, the first wave, actually coinciding with the sectorial coordinate of the section and the relative damping distance, is remarkably affected by the ratio between thickness,  $t$  and average dimensions of the section. For common values of such ratio it is easy to observe that such distance always remains much higher than the ratio relative to following waves.

The above rigorous procedure allows to solve the problems concerning the calculation of local stress conditions associated with concentrated loads and constrains preventing the free warping of the cross section of the beam. As an example, we hereby report the results obtained in [26] on the study of stress in correspondence with the joined section of an  $I$  beam subject to the three loading conditions shown by figures 7a, 7b, 7c.

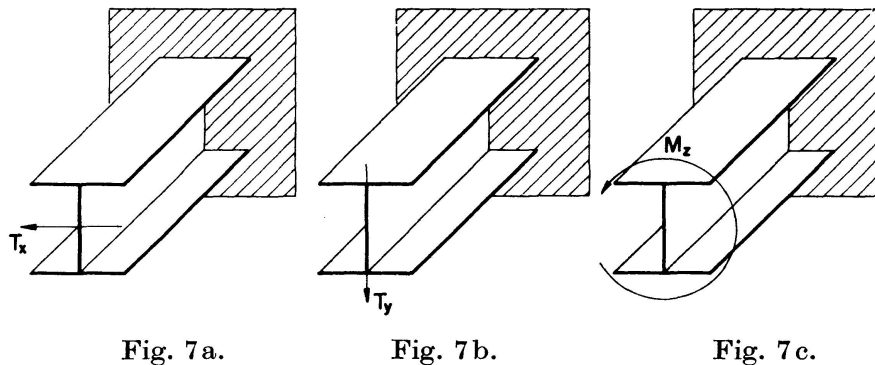

Fig. 8 shows the course of normal additional stresses in the joined section due to the application of shear  $T_x$ , and fig. 9 shows the total diagram of normal stresses  $\sigma_z$  and tangential stresses  $\tau_{zs}$ .

Analogously, figs. 10 and 11 show respectively the course of normal additional stresses and total normal and tangential stresses in case of shear  $T_y$ .

Fig. 12 shows the course of total normal and tangential stresses relative to the application of torque  $M_z$ . All values of total stresses have been calculated by supposing  $l = 5h$ .

A last interesting case is that concerning the problem of calculation of self-stress occurring in a beam because of dislocations localized in particular zones.

Fig. 13 shows the case of a distorsion tending to draw near uniformly the two sides of separation of the core of a double  $T$  beam; this case may represent the cooling of the welding joining two separate pieces of the beam core [27].

Fig. 14 shows the self-stress occurring in the section beam.

Obviously, above examples represent only a very limited aspect of possible

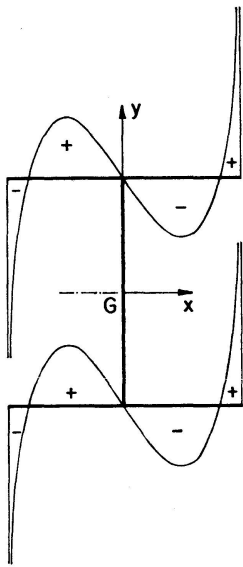

Fig. 8.

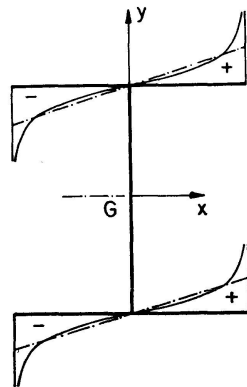

Fig. 9.

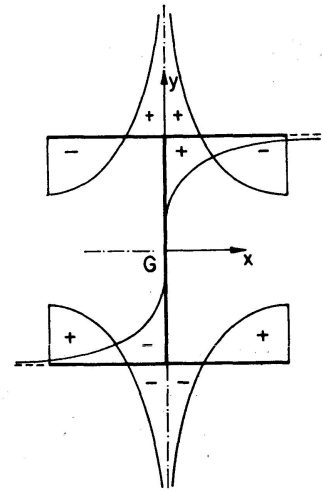
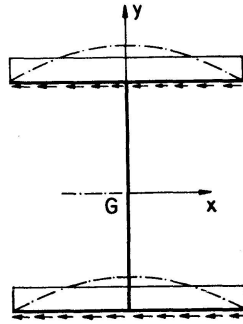

Fig. 10.

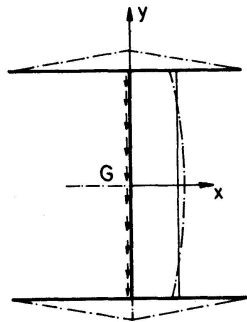
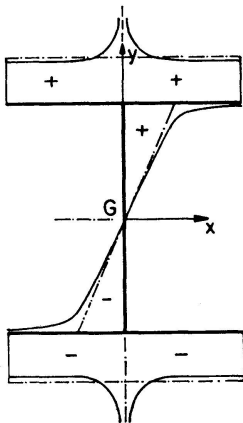

Fig. 11.

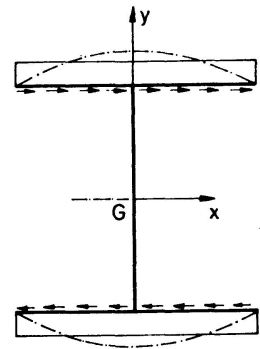
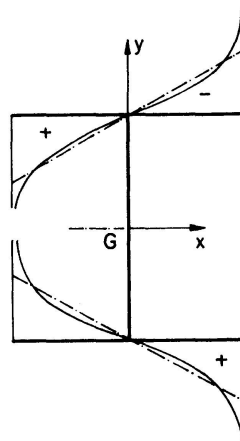

Fig. 12.

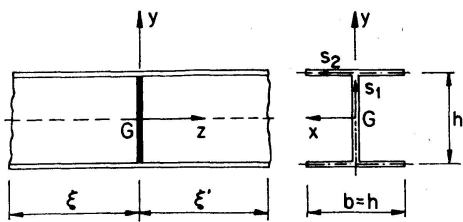

Fig. 13.

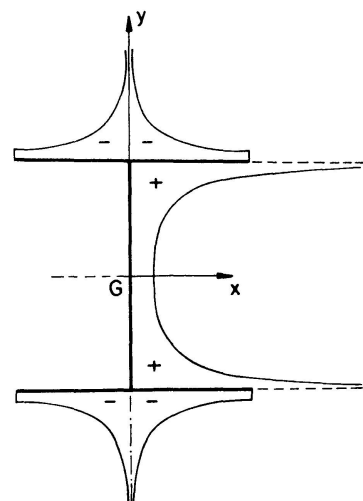

Fig. 14.



applications of proposed theory, which probably has the most advantageous possibilities of development in the field of fuselage design, where problems of distribution of loads or localization of stresses near holes or because of distortions (non uniform thermal fields) are of basic importance.

### 3. Theory of Stability

#### 3.1. Stability of a Thin Walled Beam Subject to Axial Load

We consider a thin walled beam subject on the two extreme sides to a constant distribution of normal stresses represented by  $P$ .

We will consider the case of open section, inasmuch as the stability phenomenon in case of close section is not much different from that of the full section.

With reference to fig. 15, the beam section is characterized by the centroid  $C$  and by the centre of torsion  $O$  having coordinates  $X_0, Y_0$  in regard to references axes  $X, Y$ .

The secondary buckled shape is represented by a double flexion and a torsion. If:

$$u(z), \quad v(z), \quad \varphi(z) \tag{60}$$

represent respectively the displacements along  $X$  and  $Y$  of the cross section for the two bendings and the twist rotation around the centres of torsion axes. The displacement components of a general point  $A$  are, in accordance with the sectorial area theory:

$$\begin{aligned} u_A &= u(z) + (y_0 - y)\Phi(z), \\ v_A &= v(z) - (x_0 - x)\Phi(z). \end{aligned} \tag{61}$$

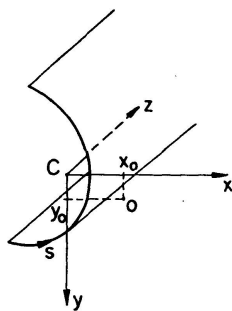

Fig. 15.

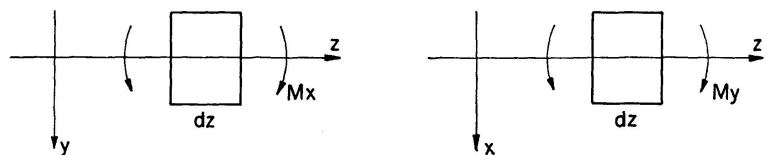

Fig. 16.

Since the only load affecting the beam is an axial load  $P$ , the bending moments  $M_x$  and  $M_y$  due to buckling caused by bending and torsion, will be:

$$\begin{aligned} M_x &= -P(v - x_0\Phi), \\ M_y &= -P(u + y_0\Phi), \end{aligned} \tag{62}$$

being:

$$\begin{aligned} v - x_0\Phi, \\ u + y_0\Phi \end{aligned} \tag{63}$$

the displacements of centroid  $C$  from fixed axis  $Z$  representing the direction of stress  $P$ . Signs are as shown in fig. 16.

Therefore, the bending equilibrium is:

$$\begin{aligned} E I_y \frac{d^2 u}{dz^2} &= -P(u + y_0 \phi), \\ E I_x \frac{d^2 v}{dz^2} &= -P(v - x_0 \phi). \end{aligned} \quad (64)$$

We impose now the torsional equilibrium condition. If we consider an elementary portion  $dA dZ$  of the beam, the displacements of its extreme section are expressed by (61).

The compression stresses  $\sigma_z dA$  transmitted through the slightly buckled stripe give as unstabilizing effects  $df_x$  and  $df_y$  respectively:

$$\begin{aligned} df_x &= -(\sigma_z dA) \frac{d^2}{dz^2} [u + (y_0 - y) \phi], \\ df_y &= -(\sigma_z dA) \frac{d^2}{dz^2} [v - (x_0 - x) \phi]. \end{aligned} \quad (65)$$

Above equations (65) cause a distributed twisting moment calculated along the axis of centers of torsion:

$$m_z = \int_A [df_x (y_0 - y) - df_y (x_0 - x)] dA = P \left( x_0 \frac{d^2 v}{dz^2} - y_0 \frac{d^2 u}{dz^2} \right) - \frac{I_0}{A} P \frac{d^2 \phi}{dz^2}, \quad (66)$$

being  $I_0$  the polar inertia moment of the section in regard to the centre of torsion. Therefore, the torsional equilibrium equation is:

$$C_1 \frac{d^4 \phi}{dz^4} - C \frac{d^2 \phi}{dz^2} = P \left( x_0 \frac{d^2 v}{dz^2} - y_0 \frac{d^2 u}{dz^2} \right) - P \frac{I_0}{A} \frac{d^2 \phi}{dz^2}. \quad (67)$$

Equations (64) and (67) have been applied to the study of stability of a beam hinged at the extreme ends with free warping or with built-in connections.

Table I, taken from VLASOV's book [22], furnishes the experimental results obtained by testing three different types of open walled beams.

It is interesting to observe the behaviour of axial load in regard to warping. By applying above mentioned procedure to the case of eccentric axial stress having eccentricities  $e_x$  and  $e_y$ , in lieu of (64) and (67), we have:

$$\begin{aligned} E I_y \frac{d^4 u}{dz^4} + P \frac{d^2 u}{dz^2} + P (y_0 - e_y) \frac{d^2 \phi}{dz^2} &= 0, \\ E I_x \frac{d^4 v}{dz^4} + P \frac{d^2 v}{dz^2} - P (x_0 - e_x) \frac{d^2 \phi}{dz^2} &= 0, \end{aligned} \quad (68)$$

$$C_1 \frac{d^4 \phi}{dz^4} - C \frac{d^2 \phi}{dz^2} + P \left( e_y \beta_1 + e_x \beta_2 + \frac{I_0}{A} \right) \frac{d^2 \phi}{dz^2} + P (y_0 - e_y) \frac{d^2 u}{dz^2} - P (x_0 - e_x) \frac{d^2 v}{dz^2} = 0.$$

Table I

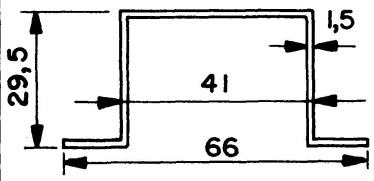
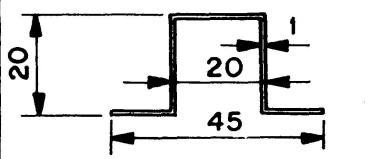
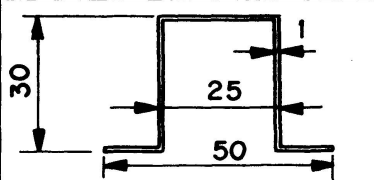
Cross sections dimensions (mm)	No. of test pieces	Length (mm)	Critical stresses (kg)		Results
			Eulero's theory	Sectorial areas theory	
	1	1.500	3.007	900	920
	2	1.300	4.398	1.174	1.150
	3	1.000	6.766	1.637	1.400
	1	1.000	1.423	412	400
	2	750	2.531	654	630
	3	500	5.694	1.318	1.200
	1	1.000	4.026	461	480
	2	750	7.158	744	780
	3	500	16.105	1.550	1.420

where:

$$\beta_1 = \frac{1}{I_x} \left( \int_A y^3 dA + \int_A x^2 y dA \right) - 2y_0, \quad (69)$$

$$\beta_2 = \frac{1}{I_y} \left( \int_A x^3 dA + \int_A x y^2 dA \right) - 2x_0.$$

It must be observed that, if:

$$e_x = x_0, \quad e_y = y_0,$$

that is if stress  $P$  is applied within the centre of torsion of the beam section, the bending and torsion secondary deformations are not coupled any more and we find again Eulero's load.

Other unstability phenomena have been studied by VLASOV and TIMOSHENKO; particularly, VLASOV furnished a theory of stability of a thin walled beam subject to axial and transversal loads. A more general formulation will confirm that such theory can well represent the unstability phenomena between bending and torsion of the beams having a symmetry axis and in the hypothesis of transversal loads acting along such axis.

### 3.2. General Formulation of Stability Problem

We consider an open section thin beam subject on the lateral side to loads  $Q_x^0(z, s)$ ,  $R_y^0(z, s)$ ,  $Q_z^0(z, s)$  and subject also to general twisting actions. The stress in the wall is represented by the three stress components:

$$\begin{aligned}
 & \tau_{xz}(z, s), \\
 & \tau_{yz}(z, s), \\
 & \sigma_z(z, s).
 \end{aligned} \tag{70}$$

The thin walled beam motion corresponding to unstability secondary buckled shape will be generally represented by two flexional buckled shapes, by a torsional and by an extensional buckled shape. Taking into consideration an element  $dA dz$  of the thin wall in the buckled condition, the unstability actions will be:

1. Transversal and axial forces due to the different inclination of the fibers of the wall in regard to the fixed reference axes.
2. Tilting couples, tending to rotate the element, due to the new components of elementary forces acting along the buckled fibers in regard to the fixed reference axes.
3. Transfer couples due to translation of elementary forces during the element's motion.

With this method we obtain the basic system:

$$\begin{aligned}
 E I_y \frac{d^4 u}{dz^4} &= \int_A \left\{ \frac{d}{dz} \left( \sigma_z \frac{du}{dz} \right) + \frac{d^2}{dz^2} \left[ \frac{dv}{dz} (\tau_{zy} x - \tau_{zx} y) \right] + \frac{d}{dz} \left[ \sigma_z (y_0 - y) \frac{d\phi}{dz} \right] \right. \\
 &\quad - \frac{d}{dz} (\tau_{zy} \phi) + \frac{d^2}{dz^2} \left[ \frac{d\phi}{dz} \tau_{zx} (y_0 - y) x - \frac{d\phi}{dz} \tau_{zy} (x_0 - x) x \right] \\
 &\quad \left. - \frac{d^2}{dz^2} \left( \frac{d\phi}{dz} \tau_{zx} \omega \right) + \frac{d^2}{dz^2} (\tau_{zx} w) \right\} dA \\
 &\quad - \int_S \left\{ \frac{d}{dz} \left[ Q_x^0 \left( \frac{du}{dz} x + \frac{dv}{dz} y \right) \right] - \frac{d}{dz} \left[ Q_x^0 \frac{d\phi}{dz} \omega \right] \right. \\
 &\quad \left. + \frac{d}{dz} (Q_x^0 w) + Q_x^0 - \frac{\partial Q_z^0}{\partial z} x \right\} ds,
 \end{aligned} \tag{71}$$

$$\begin{aligned}
 E I_x \frac{d^4 v}{dz^4} &= \int_A \left\{ \frac{d}{dz} \left( \sigma_z \frac{dv}{dz} \right) - \frac{d^2}{dz^2} \left[ \frac{du}{dz} (\tau_{zy} x - \tau_{zx} y) \right] - \frac{d}{dz} \left[ \sigma_z (x_0 - x) \frac{d\phi}{dz} \right] \right. \\
 &\quad \left. + \frac{d}{dz} (\tau_{zx} \phi) + \frac{d^2}{dz^2} \left[ \frac{d\phi}{dz} \tau_{zx} (y_0 - y) y - \frac{d\phi}{dz} \tau_{zy} (x_0 - x) y \right] \right. \\
 &\quad \left. - \frac{d^2}{dz^2} \left( \frac{d\phi}{dz} \tau_{zy} \omega \right) + \frac{d^2}{dz^2} (\tau_{zy} w) \right\} dA \\
 &\quad - \int_S \left\{ \frac{d}{dz} \left[ Q_y^0 \left( \frac{du}{dz} x + \frac{dv}{dz} y \right) \right] - \frac{d}{dz} \left[ Q_y^0 \frac{d\phi}{dz} \omega \right] \right. \\
 &\quad \left. + \frac{d}{dz} (Q_y^0 w) + Q_y^0 - \frac{\partial Q_z^0}{\partial z} y \right\} ds,
 \end{aligned}$$

$$\begin{aligned}
-E A \frac{d^2 w}{dz^2} &= - \int_A \frac{d}{dz} \left\{ \left( \tau_{zx} \frac{du}{dz} + \tau_{zy} \frac{dv}{dz} \right) - \frac{d\phi}{dz} [\tau_{zx} (y_0 - y) - \tau_{zy} (x_0 - x)] \right\} dA \\
&\quad + \int_S Q_z^0 ds, \\
C_1 \frac{d^4 \phi}{dz^4} - C \frac{d^2 \phi}{dz^2} &= \int_A \left\{ \frac{d}{dz} \left[ \sigma_z \frac{du}{dz} (y_0 - y) - \sigma_z \frac{dv}{dz} (x_0 - x) \right] - \frac{d}{dz} (\tau_{zx} v - \tau_{zy} u) \right. \\
&\quad + \frac{d}{dz} \left[ \sigma_z \frac{d\phi}{dz} (x_0 - x)^2 + \sigma_z \frac{d\phi}{dz} (y_0 - y)^2 \right] - \frac{d^2}{dz^2} \left[ \left( \tau_{zx} \frac{du}{dz} + \tau_{zy} \frac{dv}{dz} \right) \omega \right] \\
&\quad \left. - \frac{d^2}{dz^2} \left[ \frac{d\phi}{dz} \tau_{zx} (y_0 - y) - \frac{d\phi}{dz} \tau_{zy} (x_0 - x) \right] \omega \right\} dA \quad (71) \\
&\quad + \int_S \left\{ - (Q_x^0 v - Q_y^0 u) + [Q_x^0 (x_0 - x) + Q_y^0 (y_0 - y)] \phi \right. \\
&\quad \left. + Q_x^0 (y_0 - y) - Q_y^0 (x_0 - x) + \frac{\partial Q_z^0}{\partial z} \omega \right\} ds.
\end{aligned}$$

This system includes all the instability cases of the thin walled beam subject to general distribution of forces and distortions. Such system can be applied to the various specific cases by expressing the stresses and the loads applied. With this procedure we can study the instability phenomena associated with the combination of the bending moments  $M_x$  and  $M_y$ , shear stresses  $T_x$  and  $T_y$ , axial load  $N_z$ , twisting moment  $M_z$ , and bimoment. In addition to the already known results, in some cases unstabilizing effects, not considered by VLASOV's formulation, are pointed out.

Such omissions, mainly due to the fact that no account was taken of unstabilizing axial components of tangential stresses relative to the main equilibrium condition, sometimes lead to remarkably different calculations of critical loads. In fact, the axial components of tangential stresses are the only ones which cause the instability phenomenon, in accordance with GREENHILL, of a beam subject to torsion; in case of a beam subject to bending and shear along  $x$  and  $y$ , we have the same effect:

$$\begin{aligned}
&\frac{d^2}{dz^2} \left[ \frac{dv}{dz} (T_y x_0 - T_x y_0) \right], \\
&-\frac{d^2}{dz^2} \left[ \frac{du}{dz} (T_y x_0 - T_x y_0) \right]. \quad (72)
\end{aligned}$$

With the assumption of nullity of internal stresses resultants, from system (71) we obtain the general equations of stability of a thin walled beam subject to dislocation:

$$\begin{aligned}
E I_y \frac{d^4 u}{dz^4} &= \int_A \frac{d^2}{dz^2} \left\{ \frac{d\phi}{dz} [\tau_{zx} (y_0 - y) x - \tau_{zy} (x_0 - x) x] - \frac{d\phi}{dz} \tau_{zx} \omega \right\} dA, \\
E I_x \frac{d^4 v}{dz^4} &= \int_A \frac{d^2}{dz^2} \left\{ \frac{d\phi}{dz} [\tau_{zx} (y_0 - y) y - \tau_{zy} (x_0 - x) y] - \frac{d\phi}{dz} \tau_{zy} \omega \right\} dA, \quad (73)
\end{aligned}$$

$$-EA \frac{d^2 w}{dz^2} = 0,$$

$$C_1 \frac{d^4 \phi}{dz^4} - C \frac{d^2 \phi}{dz^2} = \int_A \left\{ \frac{d}{dz} \left[ \frac{d\phi}{dz} \sigma_z (x^2 + y^2) \right] - \frac{d^2}{dz^2} \left[ \frac{du}{dz} \tau_{zx} \omega + \frac{dv}{dz} \tau_{zy} \omega \right] \right. \tag{73}$$

$$\left. - \frac{d^2}{dz^2} \left[ \frac{d\phi}{dz} \tau_{zx} (y_0 - y) - \frac{d\phi}{dz} \tau_{zy} (x_0 - x) \right] \right\} \omega.$$

System (73) has been applied to the study of effects by self-stresses due to residual stresses, non uniform thermal fields, and prestressing.

With reference to the first case of system (73), we infer that the value of the actual rigidity  $C$  of the metal section is:

$$C^* = C + \int_A \sigma_{res.} (x^2 + y^2) dA. \tag{74}$$

With reference to figures 17 and 18, showing the values of residual stresses calculated at Liegi Laboratory [34], and assuming the theoretical scheme of fig. 19, for the actual torsional rigidity  $C$ , we have:

$$C^* = \frac{G}{3} (4B t_f^3 + 2h t_a^3) + t_f B^3 \left( \frac{R_i}{3} - R_e \right) + 2t_f h^2 B (R_i - R_e) + \frac{2t_a h^3}{5} \left( R'_e - \frac{2}{3} R'_i \right). \tag{75}$$

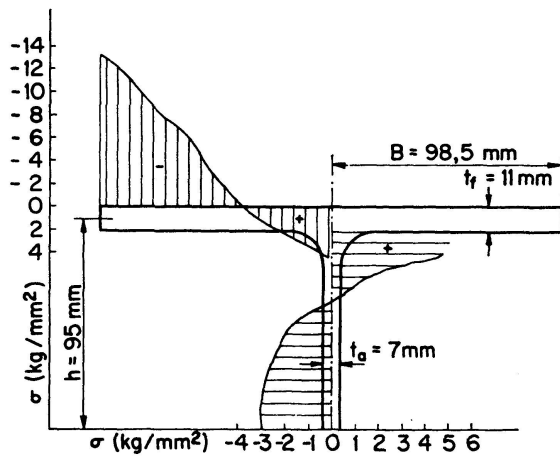

Fig. 17.

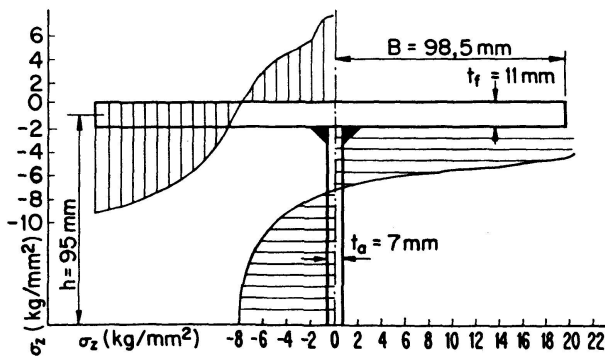

Fig. 18.

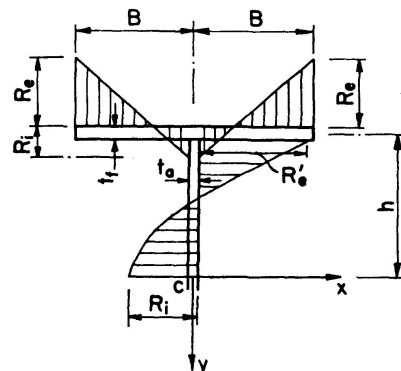

Fig. 19.

Fig. 19 shows the values of  $B$ ,  $t_a$ ,  $t_e$ ,  $h$ ,  $R_l$ ,  $R_e$ ,  $R_i$ . By applying to (75) the values of residual stresses shown by figures 17 and 18, we obtain a reduction amounting to 18.5% of the traditional torsional rigidity.

Since the residual stresses are usually due to non uniform cooling of the section, the extreme wings which cool sooner, are stressed. In fact, the reduction of traditional rigidity is due to the unstabilizing effect of stressed fibers, which being farther from the centre of torsion than the stretched fibers, prevail on these latter.

Another example of the influence of a self-stress on the quality of the thin walled beam equilibrium, is represented by fig. 20, showing the course of temperature variation along the beam section.

Fig. 21 shows the corresponding normal stresses.

The critical temperature  $T_{0\text{crit}}$  is:

$$T_{0\text{crit}} = -\frac{1}{J} \left( C_1 \frac{\pi^2}{l^2} + C \right), \quad (76)$$

where: 
$$J = \frac{1}{T_0} \int_A \sigma_z (x^2 + y^2) dA. \quad (77)$$

Assuming:  $t_a = t_f = t$ ,  $h = 4B$ ,  $\frac{t}{h} = \frac{1}{40}$ ,  $\frac{h}{l} = \frac{1}{40}$ ,  $\frac{B}{l} = \frac{1}{160}$ ,  $\frac{t}{B} = \frac{1}{10}$ ,

we have: 
$$T_{0\text{crit}} = 172.5^\circ \text{C}.$$

The effect of self-stress can also be reported for the instability phenomena associated with external forces.

Fig. 22 shows, as an example, the instability ranges of a double  $T$  section subject to thermal coaction, as in fig. 23, and to bending moment or axial load.

A very interesting problem of instability due to dislocations is represented by the stress of a thin walled beam caused by prestressing. Fig. 24 shows the beam with the prestressing cable inserted.

The general equations are obtained from system (73); the stability of a prestressed thin walled beam can be caused by:

1. Eccentric action in regard to the centre of torsion of normal stresses in the beam section and of prestressing stress  $N$  due to the torsional buckled shape.
2. Eccentric actions in regard to centroid  $C$  of cross section of normal components of tangential stresses and prestressing stress always due to torsional buckled shape.
3. Warping action due to the sectorial coordinate because of axial components of tangential stresses and prestressing stress during the occurring of flexional and torsional buckled shape.
4. Bending action caused by displacements of tangential stresses and shear components of prestressing stress due to the section warping ensuing the secondary torsional buckled shape.

If the wire is rectilinear and parallel to the beam axis, the only unstabilizing effect occurs in point (1), therefore the instability phenomenon is represented

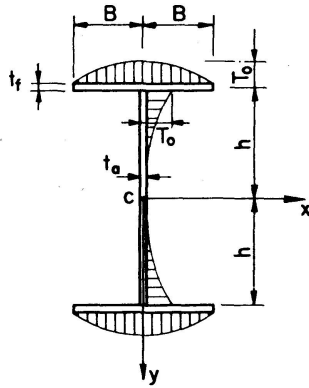

Fig. 20.

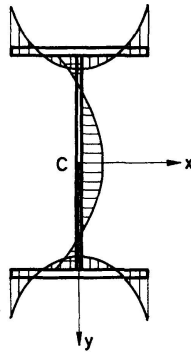

Fig. 21.

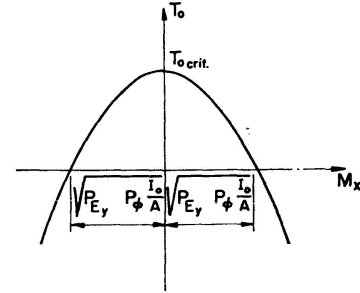

Fig. 22.

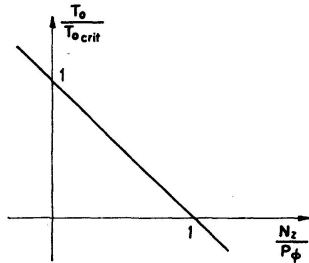

Fig. 23.

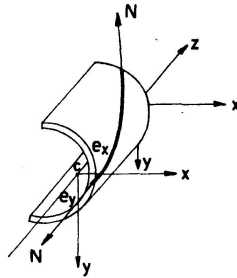

Fig. 24.

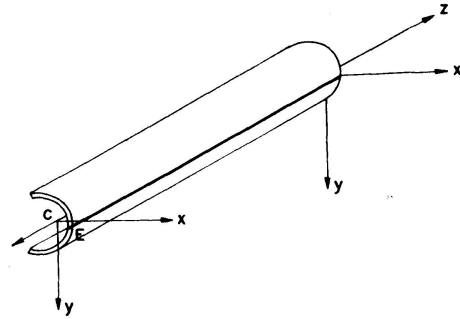

Fig. 25.

only by the torsional buckled shape. In this case, with reference to fig. 25, and in case of free warping of extreme sections, the eventual critical stress is:

$$N_{crit.} = \frac{C_1 \frac{\pi^2}{l^2} + C}{\frac{I_x + I_y}{A} + e_y \tilde{\alpha}_y + e_x \tilde{\alpha}_x - e_x^2 - e_y^2}, \tag{78}$$

where:

$$\tilde{\alpha}_x = \frac{1}{I_x} \left( \int y^3 dA + \int x^2 y dA \right), \tag{79}$$

$$\tilde{\alpha}_y = \frac{1}{I_y} \left( \int x^3 dA + \int x y^2 dA \right).$$

If we assume:

$$\psi = \frac{I_x + I_y}{A} + e_y \tilde{\alpha}_y + e_x \tilde{\alpha}_x \tag{80}$$

the prestressing effect is unstabilizing if:

$$\psi > e_x^2 + e_y^2. \tag{81}$$

As a clarification of what said above concerning the simple case of prestressed rectangular thin beam, fig. 26 shows the unstabilizing actions due to the beam normal stresses, and the stabilizing actions due to the prestressing cable.



The unstabilizing actions due to normal stresses on the beam are formed by a quantity linearly variable with  $y$  and by a quantity parabolically variable.

The parabolic distribution balances the concentrated stabilizing stress caused by the cable; the figure shows the moment in regard to  $C \equiv 0$  of the linear distribution of unstabilizing forces and the stabilizing moment due to the prestressing cable.

Eccentricities  $e_x$  and  $e_y$  reducing to the minimum the value of critical prestressing stress also cause the maximum value of the denominator in (78); we have:

$$N_{crit.} = \frac{C_1 \frac{\pi^2}{l^2} + C}{\frac{I_x + I_y}{A} + \frac{1}{4}(\tilde{\alpha}_x^2 + \tilde{\alpha}_y^2)} \tag{82}$$

Fig. 27 shows two rectangular thin beams prestressed by a parabolic cable.

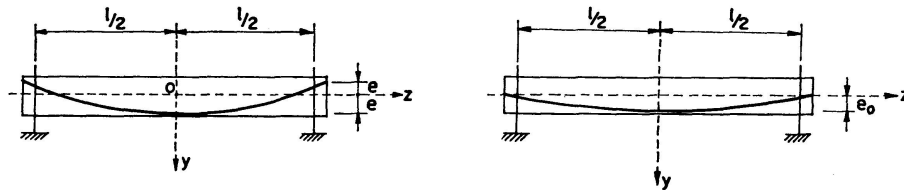
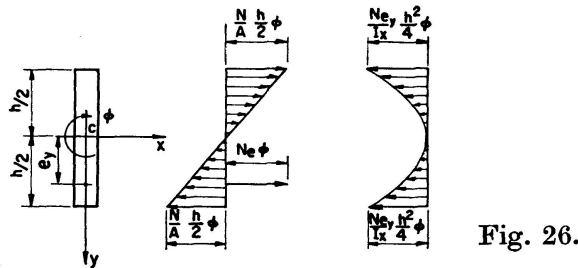

Fig. 27.

In the first case the value of critical prestressing stress is:

$$N_{crit.} \cong \frac{C \frac{\pi^2}{l^2}}{\frac{\pi^2}{l^2} \frac{I_x + I_y}{A} - 1.1 \frac{e^2}{l^2}} \tag{83}$$

In the second case it is:

$$N_{crit.} \cong \frac{C \frac{\pi^2}{l^2}}{\frac{\pi^2}{l^2} \frac{I_x + I_y}{A} - 3 \frac{e^2}{l^2}} \tag{84}$$

From above numerical applications we can conclude that for prestressed concrete beams the phenomenon of instability due to prestressing generally does not present complications. However, the reduced thickness may increase remarkably the importance of the phenomenon itself. The problem on the contrary is very important in case of prestressing of metal beams.

The problem can be extended by taking into account at the same time transversal loads effects and prestressing.

Fig. 28 shows the unstability range between prestressing stress  $N$  and external bending couples  $M_x$  and  $M_y$ ; figures 29a and 29b show the unstability ranges between a normal external stress  $P$  and prestressing stress  $N$  in the cases where compression has unstabilizing as well as stabilizing effects.

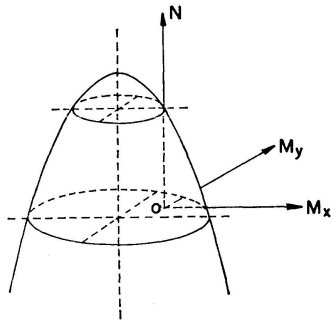

Fig. 28.

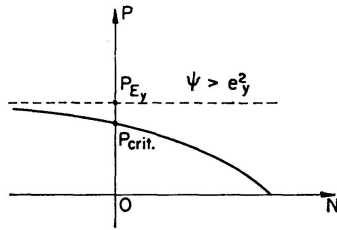

Fig. 29a.

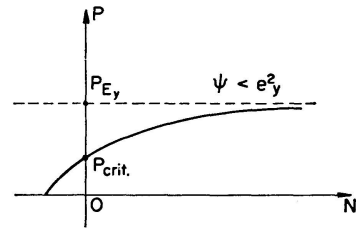

Fig. 29b.

The same procedure has been applied to the case of a thin walled beam subject to a general system of follower forces  $Q_x^0(z)$ ,  $Q_y^0(z)$ ,  $Q_z^0(z)$  and corresponding dynamic equilibrium equations have been calculated.

Among the cases considered, an interesting one is shown by fig. 30, representing the wing supporting a jet engine [35].

Fig. 31 shows the characteristic exponent representing the flexio-torsional oscillations as function of thrust  $P$ , and the resonance critical load is:

$$F_{crit.} \cong 6.99 \frac{\pi}{l} \sqrt{E I_y C}. \tag{85}$$

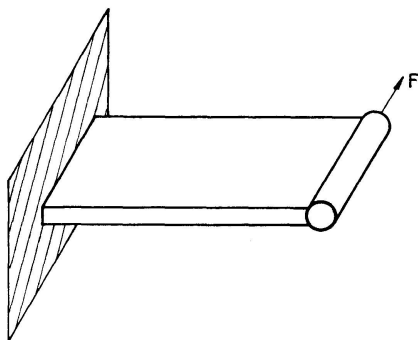

Fig. 30.

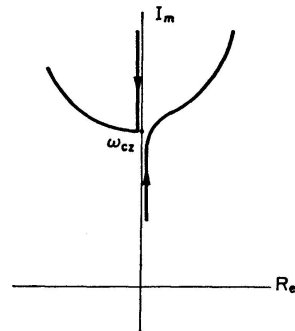

Fig. 31.

A last interesting case is that of unstability effects caused by masses traveling on the beam with flexio-torsional oscillation. Such oscillation carries the traveling mass which reacts with a Coriolis' acceleration, as shown by fig. 32.

The equation governing the dynamic equilibrium of the beam are very useful for the study of stability to lateral buckling of suspended bridges and

Langer's bridges, where masses having speed  $V$  travel continuously. In this case the critical load is affected by the masses' speed.

The equation determining the critical speed is similar to the equation determining the axial critical load.

In case of Langer's bridge, fig. 33a shows the buckled shape and fig. 33b shows the coordinates determining the position of the load on the bridge.

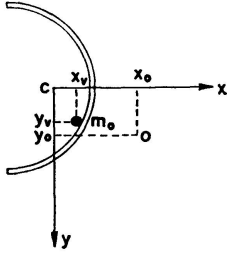

Fig. 32.

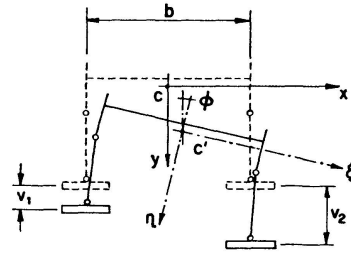

Fig. 33a.

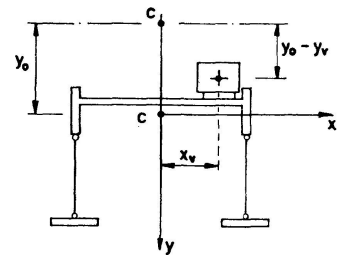

Fig. 33b.

The critical speed is obtained from:

$$\alpha^2 (\bar{V}_{2x}^2 - V^2) (\bar{V}_{2y}^2 - V^2) (\bar{V}_{2\phi}^2 - V^2) - (y_0 - y_v)^2 V^4 (\bar{V}_{2x}^2 - V^2) - \left[ -x_v V^2 - \frac{b}{2} (H_2 - H_1) \frac{g}{P_0} \right]^2 (\bar{V}_{2x}^2 - V^2) = 0, \quad (86)$$

where:

$$\begin{aligned} \frac{g}{P_0} P_{E_{2x}} - \frac{g}{P_0} (H_1 + H_2) &= \bar{V}_{2x}^2, \\ \frac{g}{P_0} P_{E_{2y}} &= \bar{V}_{2y}^2, & \alpha^2 &= x_v^2 + (y_0 - y_v)^2, \\ \frac{g}{P_0} \left[ \frac{I_0}{A} P_{2\phi} - \frac{b^2}{4} (H_1 + H_2) \right] \frac{1}{\alpha^2} &= \bar{V}_{2\phi}^2. \end{aligned} \quad (87)$$

In case of suspended bridge (fig. 34), the critical speeds are determined by:

$$\begin{aligned} &\left\{ \alpha^2 (\bar{V}_{2x}^2 + \bar{V}_{2y}^2 + \bar{V}_{2\phi}^2) - (y_0 - y_v)^2 \bar{V}_{2x}^2 - x_v^2 \bar{V}_{2y}^2 - b x_v (H_2 - H_1) \frac{g}{P_0} \right\} (V^2)^2 \\ &+ \left\{ -\alpha^2 (\bar{V}_{2x}^2 \bar{V}_{2y}^2 + \bar{V}_{2x}^2 \bar{V}_{2\phi}^2 + \bar{V}_{2y}^2 \bar{V}_{2\phi}^2) + b x_v \bar{V}_{2y}^2 (H_2 - H_1) \frac{g}{P_0} + \frac{b^2}{4} (H_2 - H_1)^2 \frac{g^2}{P_0^2} \right\} V^2 \\ &+ \frac{b^2}{4} \bar{V}_{2y}^2 \frac{g^2}{P_0^2} [(H_2 - H_1)_{crit.}^2 - (H_2 - H_1)^2] = 0, \end{aligned} \quad (88)$$

where:

$$\begin{aligned} \bar{V}_{2y}^2 &= \frac{g}{P_0} P_{E_{2y}}, & \bar{V}_{2x}^2 &= \frac{g}{P_0} [P_{E_{2x}} + (H_1 + H_2)], & \bar{V}_{2\phi}^2 &= \frac{g}{P_0} \left[ \frac{I_0}{A} P_{2\phi} + \frac{b^2}{4} (H_1 + H_2) \right], \\ (H_2 - H_1)_{crit.}^2 &= \frac{4 \alpha^2 \bar{V}_{2x}^2 \bar{V}_{2\phi}^2}{b^2} \frac{P_0^2}{g^2} \end{aligned} \quad (89)$$

$$\text{and } P_{E_{2x}} = \frac{4\pi^2 EI_x}{l^2}, \quad P_{E_{2y}} = \frac{4\pi^2 EI_y}{l^2}, \quad P_{E_2\phi} = \left( c_1 \frac{4\pi^2}{l^2} + c \right) \frac{A}{I_0}. \quad (90)$$

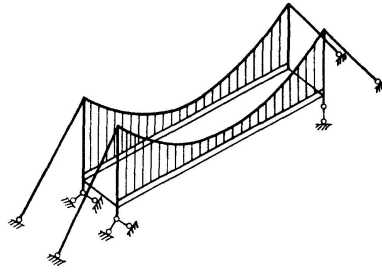

Fig. 34.

### Bibliography

1. S. P. TIMOSHENKO: "On the stability in plane bending of a T-beam". Bull. Pol. Inst. St. Petersburg 4—5 (1905).
2. H. WAGNER: «Verdrehung und Knickung von offenen Profilen». 25th Anniversary Publication T. Hochschule (Danzig, 1929).
3. A. OSTENFELD: "Politeknisk Laereanstalts Laboratorium for Bygningsstatik". Meddelelse N. 5 (Kopenhagen, 1931).
4. F. and H. BLEICH: "Bending torsion and buckling of bars composed of thin walls". Prelim. Pub. 2nd Cong. Int. A. Bridge and Structural Eng., p. 861 (Berlin, 1936).
5. R. KAPPUS: «Drillknicken zentrisch gedrückter Stäbe mit offenem Profil und elastischem Bereich». (Luftfahrt-Forschung (1937).
6. S. P. TIMOSHENKO: "Theory of bending torsion and buckling of thin walled members of open cross section". Jour. Franklin Inst. (1945).
7. J. H. GOODIER: "The buckling of compressed bars by torsion and flexure". Cornell Univ. Eng. Expt. Sta. Bull. (December 1937).
8. V. Z. VLASOV: «Théorie approchée des structures prismatiques flexibles en voiles minces et des plaques; calcul de stabilité, calcul des vibrations». Etudes sur la dynamique des constructions. Recueil d'articles sous la direction de Rabinowitch (Moscow, Stroizdat, 1947).
9. A. L. GOLDENWEYSER: «Stabilité des pièces longues en voiles minces sous l'action d'une force longitudinale pour différents cas de condition aux limites». Etudes du Laboratoire de la Statique des Constructions, Z.N.I.P.S. (1941).
10. A. R. RIANITZIN: «De la détermination des caractéristiques géométriques sectorielles de la section transversale des pièces longues à parois minces». Z.N.I.P.S. (1941).
11. G. KRALL: «Sulla stabilità dell'equilibrio di barre in profilato sottile. Nota I e II». Rend. Acc. Naz. Lincei, Classe Scienze Fis. e Mat. s. 8, vol. 32, p. 791, vol. 33, p. 13 (1962).
12. VON KARMAN and CHRISTENSEN: "Methods of analysis for torsion with variable twist". Journal of the aeronautical sciences, vol. 11, n. 2 (1944).
13. VON KARMAN and WEI-ZANG-CHIEN: "Torsion with variable twist". Journal of the aeronautical sciences, vol. 13 (1964).
14. P. CICALA: «Sul calcolo dei solidi cilindrici in parete sottile». L'Aerotecnica 1<sup>o</sup> (giugno 1940).
15. P. CICALA: «Sul calcolo dei solidi cilindrici in parete sottile». L'Aerotecnica 2<sup>o</sup> (luglio-agosto 1940).
16. P. CICALA: «Sul calcolo dei solidi cilindrici in parete sottile». L'Aerotecnica 3<sup>o</sup> (ottobre 1940).

17. P. CICALA: «Sul calcolo delle strutture a guscio». *L'Aerotecnica* (sett. 1946).
18. P. CICALA: «Sul calcolo delle strutture a guscio». *L'Aerotecnica* (dic. 1946).
19. P. CICALA: «Sul calcolo delle strutture a guscio». *L'Aerotecnica* (feb. 1947).
20. P. CICALA: «Sul calcolo delle strutture a guscio». *L'Aerotecnica* (apr. 1947).
21. M. CAPURSO: «La trattazione di Jourawski per le sezioni pluriconnesse». *Rend. Acc. di Scienze Fisiche e Matematiche di Napoli* s. 4, vol. 28 (1961).
22. V. Z. VLASOV: "Thin walled elastic beams". (Jerusalem, Israel Program for Scientific Translation, 1961.) Publ. for the National Science Foundation, Washington D.C.
23. M. CAPURSO: «Sul calcolo delle travi di parete sottile in presenza di forze e distorsioni. Nota I: la teoria e le equazioni fondamentali». *Ric. Sci.* 34 (II-A), vol. 6, 213 (1964).
24. M. CAPURSO: «Sul calcolo delle travi di parete sottile in presenza di forze e distorsioni. Nota II: La generalizzazione del problema del de Saint-Venant». *Ric. Sc.* 34 (II-A), vol. 6, 241 (1964).
25. M. CAPURSO: «Sul calcolo delle travi di parete sottile in presenza di forze e distorsioni. Nota III: Complementi analitici: Il calcolo delle funzioni caratteristiche per alcuni tipi di travi di parete sottile di comune impiego». *Ric. Sc.* 34 (II-A), vol. 7, 5 (1964).
26. M. CAPURSO: «Sul calcolo delle travi di parete sottile in presenza di forze e distorsioni. Nota IV: L'effetto dei carichi trasversali sulle sollecitazioni e spostamenti delle travi di parete sottile». *Ric. Sc.* 34 (II-A), vol. 7, 43 (1964).
27. M. CAPURSO: «Sul calcolo delle travi di parete sottile in presenza di forze e distorsioni. Nota V: le distorsioni». *Ric. Sc.* 34 (II-A), p. 85—106 (1964).
28. M. COMO: «Equilibri instabili nelle travi di sezione aperta sottile soggette a distribuzioni di forze e distorsioni. Nota I: Le equazioni generali della dinamica delle travi di sezione aperta sottile soggette a distribuzioni di distorsioni e forze conservative». *Ric. Sc.* 34 (II-A), 177—212 (1964).
29. M. COMO: «Equilibri instabili nelle travi di sezione aperta sottile soggette a distribuzioni di forze e distorsioni. Nota II: Equilibri instabili nelle travi di sezione aperta sottile soggette a distribuzioni di forze conservative». *Ric. Sc.* 34 (II-A), p. 493—528 (1964).
30. M. COMO: «Equilibri instabili nelle travi di sezione aperta sottile soggette a distribuzioni di forze e distorsioni. Nota III: Dinamica e stabilità della trave di sezione aperta sottile soggetta ad un generale sistema di distorsioni». *Ric. Sc.* 34 (II-A), p. 529—550 (1964).
31. M. COMO: «Equilibri instabili nelle travi di sezione aperta sottile soggette a distribuzioni di forze e distorsioni. Nota IV: Stabilità dell'equilibrio elastico della trave sottile precompressa». *Ric. Sc.* 34 (II-A), p. 465—498 (1964).
32. M. COMO: «Equilibri instabili nelle travi di sezione aperta sottile soggette a distribuzioni di forze e distorsioni. Nota V: Sulla stabilità dell'equilibrio della trave di sezione sottile soggetta a distribuzioni di forze non conservative». *Ric. Sc.* 34 (II-A), p. 499—524 (1964).
33. M. COMO: «Equilibri instabili nelle travi di sezione aperta sottile soggette a distribuzioni di forze e distorsioni. Nota VI: Sulla stabilità dell'equilibrio elastico della trave di sezione sottile percorsa da masse in moto». *Ric. Sc.* 34 (II-A), p. 525—544 (1964).
34. C.E.C.M.: «Rapport sur les essais de flambement executés dans le cadre des travaux de la sous-commission 'Essais' de la Convention de la Construction Metallique». (Nov. 1963.)
35. M. COMO: "Lateral buckling of a cantilever subject to a transversal follower force". *Int. Journ. of Solids and Struct.* Vol. II, No. 3 (1966).
36. E. GIANGRECO, M. CAPURSO, M. COMO: "Static and stability of thin walled elastic beams". *Scientific Report. A.F.* 61 (052)—813.

### Summary

The first studies conducted by TIMOSHENKO and VLASOV on the problem of thin walled beams are mentioned, as well as the more recent studies concerning the static behaviour and the equilibrium instability.

Then the problem is systematically and completely formulated through a series of theoretical researches conducted at the Institute of Structural Engineering of Naples University and sponsored by the C.N.R. and O.A.R.

In these studies the most general combinations of stresses due to loads or distortions are considered; under the static aspect the study is conducted more rigorously than in the sectorial areas theory, by introducing only the hypothesis of transversal indeformability of the beam section; as far as the equilibrium instability is concerned, a synthesis theory, including all possible combinations of unstable equilibrium, is furnished.

The results obtained are applied in practice to different types of sections, of frequent technical application, with specific reference to problems arising due to residual stresses, non-uniform thermic variations, and prestressing.

### Résumé

Il est d'abord fait mention des premières recherches exécutées par TIMOSHENKO et VLASOV sur le problème des poutres à parois minces, ainsi que des études plus récentes relatives au comportement statique et à l'instabilité des équilibres.

Le problème est ensuite formulé d'une manière systématique et complète grâce à une série d'études théoriques effectuées à l'Institut des Charpentes de l'Université de Naples sous l'égide du C.N.R. et de l'O.A.R.

On y considère les combinaisons les plus générales des efforts dus aux charges ou aux déformations; du point de vue statique, l'étude est menée de façon plus rigoureuse que ce ne l'est fait dans la théorie des surfaces sectorielles, en ne faisant intervenir que l'hypothèse de l'indéformabilité transversale des sections des poutres; en ce qui concerne l'instabilité des équilibres, on présente une théorie synthétique qui comprend toutes les combinaisons possibles d'équilibre instable.

Les résultats obtenus sont appliqués pratiquement à des sections de types différents que l'on rencontre souvent dans la pratique, eu égard plus particulièrement aux problèmes qui interviennent du fait des contraintes résiduelles, des variations thermiques non uniformes et de la précontrainte.

### Zusammenfassung

Der Verfasser erwähnt sowohl die ersten durch TIMOSHENKO und VLASOV durchgeführten Untersuchungen über das Problem der dünnwandigen Träger, als auch die neueren Untersuchungen bezüglich statischen Verhaltens und labilen Gleichgewichts.

Anschließend wird das Problem systematisch und umfassend formuliert durch eine Reihe von Untersuchungen, die im Istituto di Tecnica delle Costruzioni der Università di Napoli unter dem Patronat des C.N.R. und der O.A.R. durchgeführt wurden.

In diesen Untersuchungen wurden die allgemeinsten Fälle von Spannungs-Kombination infolge Belastungen oder Verdrehungen berücksichtigt. In statischer Hinsicht wurden die Untersuchungen strenger durchgeführt als nach der Theorie der sektoriellen Flächen, indem einzig die Hypothese der Unverformbarkeit des Trägerquerschnitts eingeführt wurde. Bezüglich des labilen Gleichgewichts wird eine Theorie angegeben, die alle möglichen Kombinationen von labilen Gleichgewichten einschließt.

Die so erhaltenen Ergebnisse werden bei verschiedenen Querschnittstypen mit häufiger technischer Anwendung praktisch verwertet, speziell im Zusammenhang mit Problemen, die durch Eigenspannungen, ungleichmäßige thermische Änderungen und Vorspannung hervorgerufen werden.