

Zeitschrift: Schweizerische mineralogische und petrographische Mitteilungen =
Bulletin suisse de minéralogie et pétrographie

Band: 70 (1990)

Heft: 2

Artikel: Plutonic alkaline series : Daly gap intermediate compositions for liquids
filling up crustal magma chambers

Autor: Bonin, Bernard / Giret, André

DOI: <https://doi.org/10.5169/seals-53611>

Nutzungsbedingungen

Die ETH-Bibliothek ist die Anbieterin der digitalisierten Zeitschriften auf E-Periodica. Sie besitzt keine Urheberrechte an den Zeitschriften und ist nicht verantwortlich für deren Inhalte. Die Rechte liegen in der Regel bei den Herausgebern beziehungsweise den externen Rechteinhabern. Das Veröffentlichen von Bildern in Print- und Online-Publikationen sowie auf Social Media-Kanälen oder Webseiten ist nur mit vorheriger Genehmigung der Rechteinhaber erlaubt. [Mehr erfahren](#)

Conditions d'utilisation

L'ETH Library est le fournisseur des revues numérisées. Elle ne détient aucun droit d'auteur sur les revues et n'est pas responsable de leur contenu. En règle générale, les droits sont détenus par les éditeurs ou les détenteurs de droits externes. La reproduction d'images dans des publications imprimées ou en ligne ainsi que sur des canaux de médias sociaux ou des sites web n'est autorisée qu'avec l'accord préalable des détenteurs des droits. [En savoir plus](#)

Terms of use

The ETH Library is the provider of the digitised journals. It does not own any copyrights to the journals and is not responsible for their content. The rights usually lie with the publishers or the external rights holders. Publishing images in print and online publications, as well as on social media channels or websites, is only permitted with the prior consent of the rights holders. [Find out more](#)

Download PDF: 24.04.2026

ETH-Bibliothek Zürich, E-Periodica, <https://www.e-periodica.ch>

Plutonic alkaline series: Daly gap and intermediate compositions for liquids filling up crustal magma chambers

by Bernard Bonin¹ and André Giret²

Abstract

Documented in numerous non-orogenic magmatic associations, bimodal populations of mafic and felsic rock-types have substantiated the "Daly gap" concept of scarce to absent intermediate compositions. The Daly gap has been described in oceanic islands as well as in continental areas. Therefore, a common explanation for both environments must be searched.

In the plutonic ring complexes emplaced at shallow levels in the crust, the common association of cumulative mafic rocks with felsic rocks derived from liquids can be explained only if intermediate magmas (e.g. from monzogabbro = hawaiite to monzonite = benmoreite compositions) have been trapped in crustal magma chambers (depths of about 15-25 km), in which they have evolved by AFC processes. The probability of the existence of intermediate liquids in the mantle is high, as numerous occurrences of mantle xenoliths in intermediate (from hawaiite to benmoreite) alkaline volcanic formations have been documented.

By comparing the cumulative population with the less evolved liquid within a plutonic alkaline province, it is possible to determine the composition of the magma filling up the magma chamber by assuming that its chemical (major and trace elements) composition is a combination of cumulates + residual liquids.

These computed liquids are more evolved than primary liquids obtained in laboratory experiments and may be derived from high-pressure (mantle) mineral fractionation. Density, not viscosity, is the major physical parameter controlling the ascent of magmas. Because of their buoyancy, moderately viscous and continuously evolving intermediate magmas can reach by diapiric ascent the ductile-brittle boundary in the crust and fill up magma chambers. Then, felsic residual liquids are produced and can move up only if fractures are open in the brittle crust, mainly by fluid overpressure and/or cauldron subsidence.

Keywords: Alkaline series, intermediate composition, magma chamber, Daly gap, cumulate, residual liquid.

Introduction

"Alkaline" is an ambiguous term, which has been used with at least four different senses (Glossary of Geology, BATES and JACKSON, 1980). If Shand's view is accepted, then, taking into consideration molecular proportions $(\text{Na}_2\text{O} + \text{K}_2\text{O}) : \text{Al}_2\text{O}_3 : \text{SiO}_2$, "an alkaline rock, if names are to mean anything, should be one in which the alkalis are in excess of 1:1.6, either alumina or silica or both deficient" (SHAND, 1922). According to this definition, the major alkaline rock types are:

1. silica undersaturated rocks which may or may not be saturated in alumina correspond respectively to miaskitic and agpaïtic associations.

The common suites are made up of theralite, essexite and feldspathoid-bearing syenites.

2. silica saturated to oversaturated rocks which are peralkaline $(\text{Na}_2\text{O} + \text{K}_2\text{O}) / \text{Al}_2\text{O}_3 > 1.00$ constitute the alkaline monzonite-syenite-granite suite. However, we shall consider here as belonging to the same suite those silica-oversaturated aluminous (biotite-bearing) rocks which are not strictly speaking alkaline but occur in the same complexes.

In his classical work on the geology of Ascension Island, DALY (1925) was the first to have stressed the marked scarcity of intermediate compositions between basalt and trachyte in oceanic island volcanic provinces. This scarcity

¹ Département des Sciences de la Terre, Université Paris-Sud, F-91405 Orsay Cédex, France.

² Laboratoire de Géologie-Pétrologie U.A. 10 CNRS, Université de Saint-Etienne, F-42023 Saint-Etienne Cédex, France.

has been found again in other oceanic island provinces such as St. Helena and Hawaii (DALY, 1933) and has been termed the "Daly gap" in his honour.

Stressing on the bimodality of rock compositions from the continental Permian Oslo rift province, BARTH (1945) has proposed that the original magmas could be represented by two distinct compositions: first, olivine alkali basalt (essexite) giving ultimately the silica undersaturated trend, and second, monzosyenite (kjelsåssite, larvikite), giving the silica (over)saturated trend.

In this paper, we shall refer to different volcanic and plutonic alkaline complexes located in both oceanic and continental environments. In most of them, a hiatus exists between mafic and felsic rock types and evokes the gap pointed out by Daly. Considering (1) that during differentiation processes the primary magma must vanish giving cumulates and residual liquids and (2) that most of the mafic plutonic rocks display cumulative characters, LAMEYRE et al. (1982) have suggested, as a working hypothesis, to consider the "Daly gap" as corresponding to the composition of this disappeared primary magma. In this scheme, the "Daly gap" does not represent sampling bias but may correspond very closely to the composition of alkaline liquids filling up crustal magma chambers.

Daly gap: fact or fantasy?

The explanation of the Daly gap was still now the matter of controversies. CHAYES (1963) has reviewed published analyses of volcanic rocks from oceanic islands on a worldwide basis and has shown that they cluster into two main groups: one basaltic to mugearitic and the other trachytic to rhyolitic/phonolitic in composition (Fig. 1).

This finding was disputed by many authors who contend that the gap is artificial and due to sampling bias. It is true that some sample bias exists and may be partly responsible for the bimodal distribution of oceanic island volcanics. However, it is extremely unlikely that it could entirely account for this distribution: in the field, a geologist is more attracted by rare samples than by common ones. Thus, basaltic rocks may be underestimated, while intermediate and evolved ones are specially searched for. So, scarcity and even lack of intermediate rocks are certainly of particular significance in terms of magma differentiation.

In his later review, CHAYES (1977) has claimed that the more abundant trachytes cannot be gen-

erated by crystal fractionation from the less abundant intermediate composition volcanics. This assumption can be questioned from two points of view. First, CLAQUE (1978) has emphasized that many indices supposed to quantify the degree of differentiation do not vary in a simple manner: fractionation models based on incompatible trace element enrichments demonstrate that neither SiO_2 , CaO, nor the Thornton-Tuttle differentiation index (D.I.) are linear functions of fractionation. In the case of Reunion Island, the transition from basalts to trachytes represents a D.I. variation of 50 wt% for a very small percentage of fractionation (ca. 15%). Thus, intermediate rocks are predicted to be quite rare.

The second point arises from the relationship between rock type abundances and degree of fractionation. It is commonly said that, in a given volcanic province, shallow fractional crystallization of a parental alkali basalt would result in predominating mafic compositions over intermediate and felsic ones. We question this idea:

In a cooling magma, crystal cumulates and a residual liquid will form. Successive paths can be computed for a complete magmatic suite from a primary magma 0 to the most evolved residual liquid n, through the crystallization of cumulates 1, 2, 3, . . . , n. At the last stage, the solid-liquid relation is:

magma 0 = S (l, n) cumulates + liquid n where S (l, n) represents the total sum of the cumulates. Thus:

- if a residual liquid n is emitted, it implies that the parent primary magma 0 has disappeared at least in zones of the magma chamber from which the liquid n was tapped,

- if the number n, which is a function of the percentage of fractionation, is high, the quantity of residual liquid n capable of being emitted is strongly reduced (BONIN and BARDINTZEFF, 1989).

We contend that the abundance of the more mafic and least evolved compositions among the different rock types defining a magmatic suite is somewhat misleading and that it must not be used directly as a proof of fractional crystallization. On the contrary:

- predominating highly evolved rock types imply that, because of lack of replenishment and/or fractionation kinetics, differentiation processes have been achieved in the magma chamber;

- in the reverse case where highly evolved rock types are scarce and mafic ones common, the differentiation process was not so efficient, because of frequent replenishment and/or too low fractionation kinetics.

In this scheme, the strong bimodality of emitted magmas in alkaline provinces implies that liquids filling up magma chambers and undergoing low pressure fractionation effects have mostly intermediate and not basaltic compositions. This hypothesis can be tested by the examination of magmatic formations containing mantle peridotite inclusions.

Peridotite-bearing magmatic formations

Upper mantle source has been proposed for a large range of volcanic rocks, because they host lherzolitic enclaves of high pressure mineralogy. GREEN et al. (1974) have reviewed the occurrence of peridotite-bearing volcanic rocks from Australia (Queensland, Tasmania) and New Zealand (Otago). Most host magmas are of alkali olivine basalt or basanite compositions with relatively rare nephelinites and melilitites. These host magmas display a strong maximum of their mg^* number ($mg^* = Mg / (Mg + Fe^{2+})$) at about 0.70, consistent with partial melting of source peridotite with olivine Fo 88–90. But, in contrast to these primary magmas, other host magmas exist with their mg^* number less than 0.60 and with

chemical compositions resembling those of classical hawaiite, mugearite, and even benmoreite magmas (Tab. 1).

GREEN et al. (1974) have suggested that these magmas have been produced by crystal fractionation, within the upper mantle, of parental basanites or alkali olivine basalts. The fractionating mineral assemblage is made up of chiefly olivine, clinopyroxene and kaersutitic hornblende. These authors have stressed the similarities existing between mantle-derived nepheline benmoreites and some plutonic nepheline syenites.

A compilation of volcanic and hypabyssal rocks in oceanic islands of the Société archipelago (French Polynesia) reveals that, besides primary picrites and alkali olivine basalts, more evolved formations host mantle lherzolite, harzburgite and dunite enclaves. They range from hawaiite, through mugearite, benmoreite and trachy-phonolite, to phonolite, and are exposed as lava flows, domes and hypabyssal dykes (Tab. 1).

In the case of Moorea Island, BLANCHARD et al. (1981) have demonstrated that the mugearite-benmoreite-trachyte suite cannot be related to the basalt-hawaiite suite by simple fractional crystallization process. Hawaiite can be derived

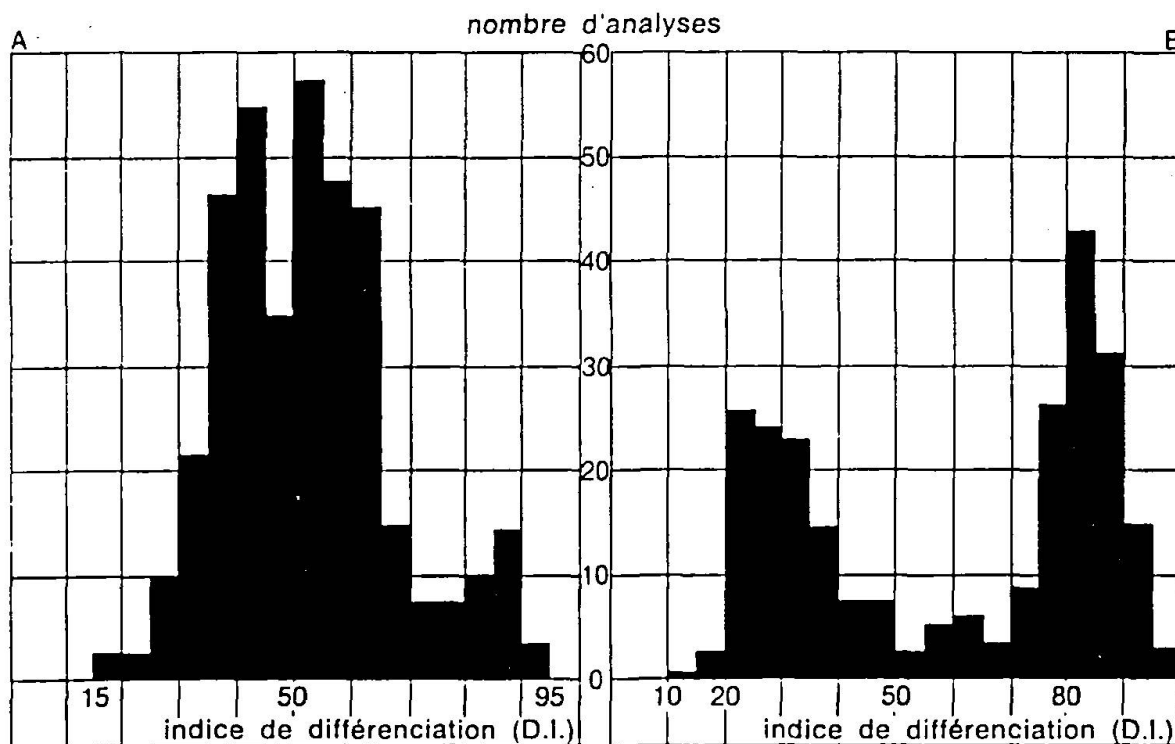

Fig. 1 Histograms showing the distribution of rock types as a function of Differentiation Index (D.I. = CIPW normative alkali feldspars + quartz + feldspathoids) (modified after MARTIN and PIWINSKI, 1972). A. Unimodal characteristics of the Tertiary orogenic suite of Cascades Mountains, U.S.A.: 379 analyses yield a maximum for D.I. = 50 (andesites). B. Bimodal characteristics of the Tertiary anorogenic alkaline suite of Ethiopia: 248 analyses emphasize a mafic maximum for D.I. = 25 (basalt) and a felsic maximum for D.I. = 90 (trachyte / rhyolite / phonolite); samples with D.I. ranging from 50 to 70 (mugearite / benmoreite) are scarce.

from basalt by fractionation of a clinopyroxene-(olivine) assemblage, but mugarite cannot be produced by fractionation of any realistic mineral assemblage. BLANCHARD et al. (1981) have favoured for both suites a model of fractional partial melting of the same mantle source generating primary magmas, subsequently modified by low pressure fractionation. Similar features can be found in the other islands and the most evolved peridotite-bearing rock is a phonolitic dome emplaced along the border fault of the Taravao caldera, in Tahiti Island (LÉOTOT, 1988). Not so commonly, hypabyssal monzonite dykes of mugarite composition may contain also inclusions of peridotite (GISBERT, 1989).

Thus, it is clear that, in oceanic as well as in continental environments, intermediate composition liquids can be produced within the upper

mantle through high pressure fractionation of mafic minerals. These compositions are good candidates for liquids filling up magma chambers. Subvolcanic complexes, which correspond to the roots of caldera volcanoes, afford supplementary evidences.

Plutonic alkaline series in subvolcanic complexes: a brief review

In oceanic islands, plutonic complexes may be exposed at the surface level or be sampled as enclaves in volcanic formations. The alkaline series is characterized by two major diverging evolutionary trends (GIRET, 1983; BONIN and GIRET, 1984):

Tab. 1 Compositions of some peridotite-bearing non-basaltic alkaline rocks in continental and oceanic centres.

	1	2	3	4	5	6	7	8
SiO ₂	54.6	50.5	45.8	48.2	55.2	60.5	60.3	49.5
TiO ₂	1.0	2.5	2.4	2.3	0.7	0.9	0.7	2.4
Al ₂ O ₃	17.7	17.0	14.0	14.0	16.2	18.2	18.4	15.8
Fe ₂ O ₃	2.2	2.7	3.5	4.2	3.7	0.5	0.6	9.1
FeO	5.8	7.6	10.4	8.0	5.0	2.6	2.9	2.5
MnO	0.2	0.1	0.2	0.2	0.0	0.0	0.3	0.2
MgO	3.7	4.6	7.4	5.7	3.2	1.2	0.6	3.6
CaO	3.9	6.1	7.7	7.0	3.6	1.8	0.8	6.7
Na ₂ O	6.4	5.0	4.7	6.5	5.2	7.3	7.4	3.9
K ₂ O	3.8	2.8	2.5	2.9	4.9	4.5	5.4	3.5
P ₂ O ₅	0.7	1.0	1.3	1.1	0.3	0.0	0.4	0.6
D.I.	68.5	53.9	42.9	54.6	68.7	84.1	89.7	51.0
Mg *	0.42	0.41	0.46	0.43	0.37	0.38	0.20	0.34
d 10 kb	2.76	2.86	2.98	2.90	2.73	2.60	2.60	2.83
log η	3.3	2.8	2.0	2.3	3.5	4.5	4.5	2.9

D.I. = C.I.P.W. normative Or + Ab + Ne + Qz. Norm calculation using $Fe^{2+} / \text{total Fe} = 0.85$. Mg* = Mg / Mg + total Fe. Densities (g/cm³) and viscosities (poises) have been calculated with the following parameters: 1100 °C, 1% H₂O and 10 kb. All the calculations have been performed using the GPP Geochemical Program Package, created by BAKER, MCBIRNEY and GEIST (1985).

Non-basaltic compositions have been selected from *continental* areas (Australia and New Zealand) and from *oceanic* islands (Société archipelago, French Polynesia).

1. Nepheline benmoreite, Mt. Mitchell (S.E. Queensland, Australia) (GREEN et al., 1974).
2. Mugarite, Redcliffe plateau, N. Bowen basin (Central Queensland, GREEN et al., 1974).
3. Nepheline hawaiiite, Flinty Marsh (S.E. Tasmania, Australia) (GREEN et al., 1974).
4. Mafic phonolite = mugarite, N.E. Otago (New Zealand) (PRICE and GREEN, 1972).
5. K-benmoreite, Moorea (Société archipelago, French Polynesia). (BLANCHARD et al., 1981).
6. Trachy-phonolite, Taravao, Tahiti (Société archipelago, French Polynesia) (LÉOTOT, 1988).
7. Phonolite, Taravao, Tahiti (Société archipelago, French Polynesia) (LÉOTOT, 1988).
8. Medium-grained monzonite = mugarite, Haamene bay, Tahaa (Société archipelago, French Polynesia) (GISBERT, 1989).

– a silica (over)saturated one, with a gabbro–monzonite–syenite–granite suite, in which mafic rock-types are always cumulative, while monzonite, syenite and granite have crystallized from a liquid. Generally, felsic types predominate over mafic cumulates.

– a silica undersaturated one, with a theralite–essexite–pulaskite–nepheline–syenite suite, in which cumulative features characterize mafic and intermediate rock-types. In this suite, highly evolved feldspathoidal types are minor with respect to large amounts of mafic rock-types (BARDINTZEFF et al., 1988; BONIN and BARDINTZEFF, 1989).

In continental areas, the same associations are present, with the addition of highly silica undersaturated associations, such as alnöite–ijolite–carbonatite and kimberlite suites (LE BAS, 1987).

A review of plutonic complexes (LAMEYRE and BOWDEN, 1982) based on the modal composition of rocks shows the existence of discrete alkaline series (Fig. 2), according to the level of silica oversaturation (quartz abundances) or undersaturation (feldspathoid abundances) during the evolution. Here, series are defined as association of rocks whose mineral compositional field extends from mafic types (e.g. gabbro) to differentiated types (e.g. granite) syenite and nepheline syenite). These petrographical series are progressive when silica undersaturated, but appear to be typically bimodal when silica (over)saturated (Figs. 2 and 3).

The alkaline ring complexes of the Niger-Nigeria younger granite province contain mafic rocks such as gabbro, leucogabbro, troctolite and anorthosite, with minor amounts of (leuco)norite, and felsic rocks such as syenite, alkali feldspar syenite and alkali feldspar granite (BENNETT, 1981; LAMEYRE and BOWDEN, 1982). The population is essentially bimodal with very scarce monzogabbro and monzonite (Fig. 3a). Mafic types are generally exposed as layered igneous formations intruded by later felsic ring dykes (JACOBSON et al., 1958; BLACK et al., 1967; LÉGER, 1985).

In the Kerguelen archipelago (Indian Ocean) (GIRET, 1983), the alkaline silica oversaturated ring complexes are made up of the same rock type association than in similar African complexes but the volume of syenite is predominant (Fig. 3b). Intermediate types, such as monzonite, monzosyenite and monzogabbro, are unfrequent and occur only as early small bodies. In most cases, mafic types, comprising melagabbro, pyroxenite and anorthosite show cumulative textures and do not represent liquid compositions.

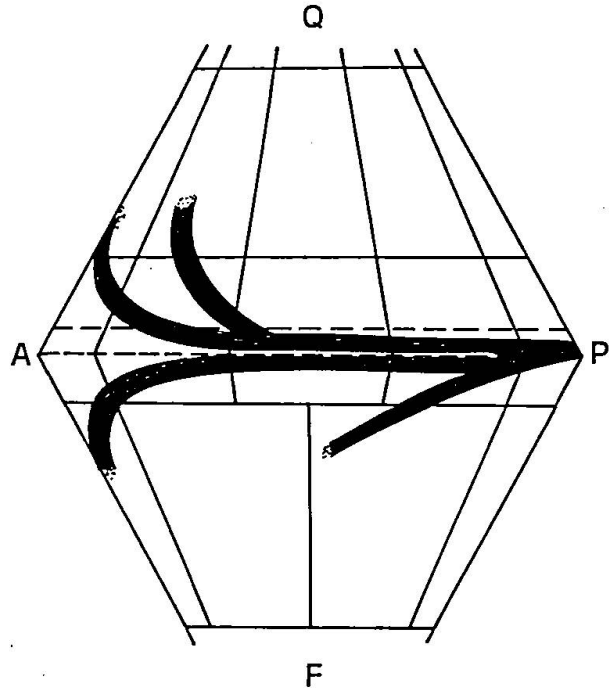

Fig. 2 Alkaline magmatic associations plotted in a modal Q-A-P-F diagram, following the method proposed by STRECKEISEN (1976), LAMEYRE and BOWDEN (1982), after BONIN and GIRET (1984).

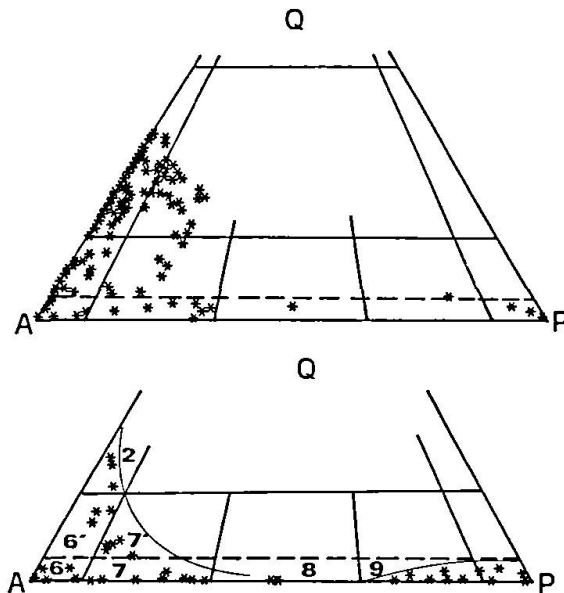

Fig. 3 Silica-oversaturated alkaline magmatic associations plotted in a modal Q-A-P diagram, modified after BONIN and GIRET (1984). a. Niger-Nigeria younger granite province (after BENNETT, 1982); b. Kerguelen archipelago syenite-granite subprovince (after GIRET, 1983). Fields numbered after STRECKEISEN (1976): 2. alkali feldspar granite, 6. alkali feldspar syenite, 6'. alkali feldspar quartz-syenite, 7. syenite, 7'. quartz-syenite, 8. monzonite, 9. monzogabbro/monzodiorite.

Compositions of Daly gap

The modal hiatus between mafic and felsic types in alkaline and transitional plutonic complexes is confirmed by silica versus oxides plots obtained from published analyses of different provinces. In Fig. 4, the variation diagrams for rocks of Ile de l'Ouest ring complex in Kerguelen archipelago (GIRET, 1983) is used as an example. Two important features are shown:

– the first is a linear distribution of the rocks, which is particularly well exposed in the TiO_2 , FeO , MnO , CaO , Na_2O and $\text{K}_2\text{O}/\text{SiO}_2$ plots,

which suggests the important role played by cumulation processes.

– the second is the "blank" between mafic and felsic types, which can be compared to the Galy gap in volcanic suites.

The shapes of the curves allow a graphic correlation between the SiO_2 average content and the different oxides. Such a graphic correlation has been made for different complexes of the Kerguelen archipelago (BONIN and GIRET, 1984), of Africa and Corsica (BONIN and GIRET, 1985) and of other provinces displaying alkaline (e.g. Fayal, METRICH et al., 1981) and transi-

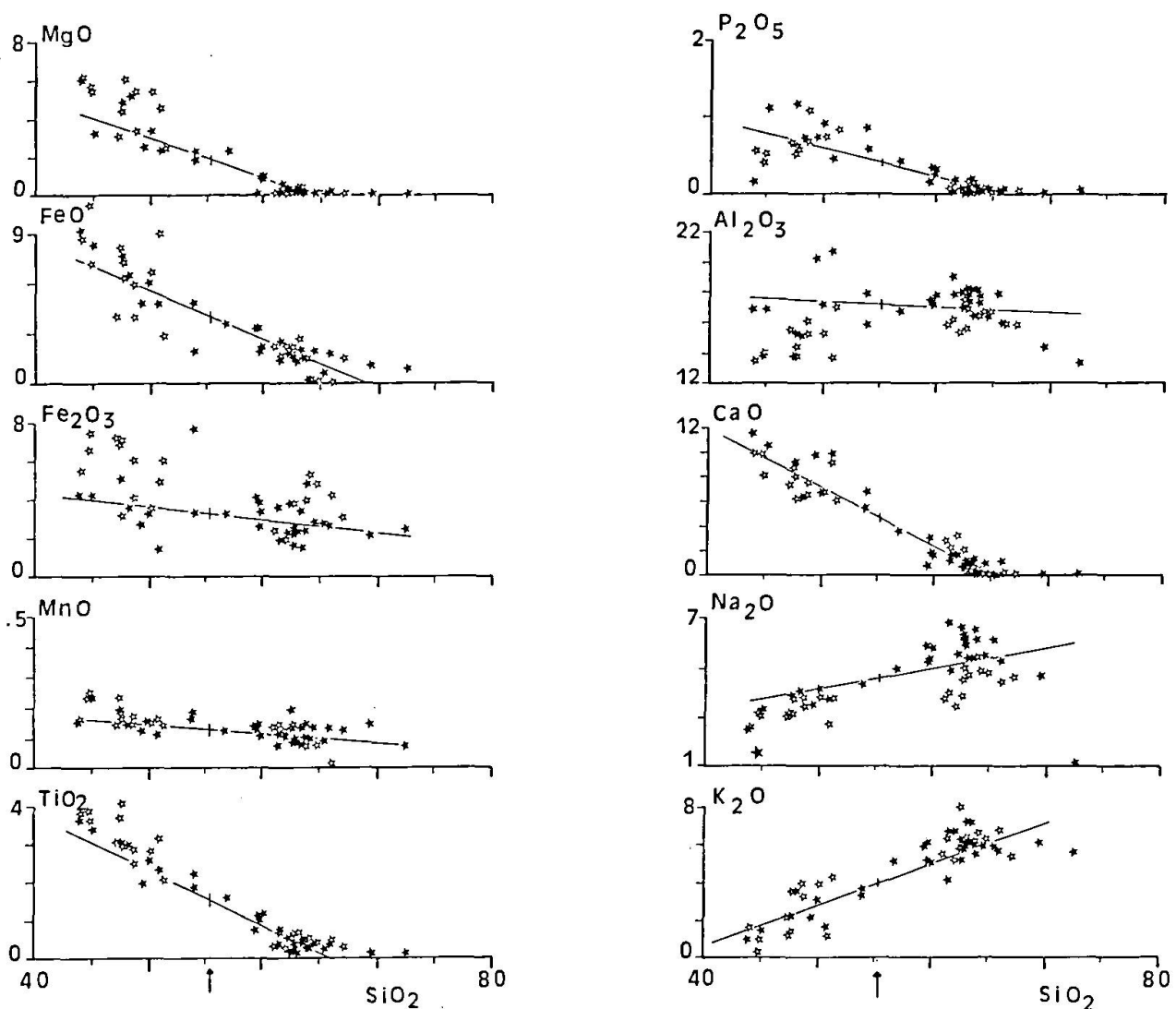

Fig. 4 Harker's oxide vs. silica diagrams for Ile de l'Ouest ring complex, Kerguelen archipelago (recalculated after GIRET, 1983; BONIN and GIRET, 1984). Regression lines have been drawn by computer, using all data points. Note that correlation coefficients are excellent (higher than 0.80) for TiO_2 , FeO , MgO , CaO , K_2O and P_2O_5 . The original magma was assumed to have a composition between the most evolved cumulative monzogabbro ($\text{SiO}_2 = 53.9$ wt%) and the least differentiated porphyritic microsyenite ($\text{SiO}_2 = 56.8$ wt%), i.e. $\text{SiO}_2 = 55.3$ wt%. Then, the composition of the original magma has been determined from regression lines for each oxide at this silica value.

tional (e.g. Mull, WALSH and CLARKE, 1982; Iceland, JAUZEIN, 1983) affinities. By this method, the compositions of the gaps have been determined (Tab. 2). The C.I.P.W. norms of such chemical compositions display alkaline, weakly silica undersaturated characteristics. D.I. which corresponds to the sum of normative alkali feldspars + nepheline is intermediate to fairly high and yields hawaiitic, mugearitic, even benmoreitic, not basaltic compositions.

If the Daly gap represents the composition of liquids filling up magma chambers, then the least evolved cumulate formations would not be melanocratic and ultramafic but mesocratic to leucocratic, mafic and plagioclase-rich.

Compositions of the primary liquids from cumulate evidences

In most alkaline plutonic complexes, mafic rocks display cumulative textures. Plagioclase-rich rocks are known as "anorthosites" (e.g. BLACK, 1965).

The Air (Niger) ring complex province contains abundant anorthosites, which consist of heterogeneous leucogabbroic cumulates in a ferrosyenitic or monzogabbroic matrix which could represent the liquid with which they were in equilibrium. From cumulus minerals in the Iskou ring complex – orthopyroxene in leuconorite, olivine in leucotroctolite, clinopyroxene and kaer-

Tab. 2 Liquids filling up magma chambers in oceanic and continental centres, calculated from Daly gap compositions.

	1	2	3	4	5	6	7	8	9	10
SiO ₂	55.3	55.5	53.8	50.3	50.9	51.0	52.1	54.9	54.0	51.1
TiO ₂	1.7	1.7	1.9	2.4	3.0	2.9	1.2	2.6	2.0	2.4
Al ₂ O ₃	17.4	17.2	17.0	17.6	15.0	16.2	15.3	13.6	13.5	14.8
Fe ₂ O ₃	3.4	3.3	1.5	2.7	2.5	2.3	7.8	3.0	4.3	6.9
FeO	4.1	4.0	5.8	9.6	8.8	8.4	n.d.	8.8	8.2	6.7
MnO	0.1	0.2	0.2	0.1	0.1	0.2	0.1	0.2	0.2	0.1
MgO	2.0	2.0	2.8	2.3	4.9	4.1	7.7	2.5	3.0	3.1
CaO	4.7	4.1	5.4	6.4	8.0	7.7	6.8	4.3	6.5	6.8
Na ₂ O	4.6	4.6	5.6	4.9	3.8	4.2	3.2	3.9	4.0	4.0
K ₂ O	4.0	5.1	2.9	2.6	1.4	1.7	3.1	3.2	2.0	1.1
D.I.	63.9	67.6	62.1	52.4	41.8	45.3	48.3	60.5	52.1	45.5
Mg *	0.28	0.30	0.37	0.23	0.41	0.37	0.62	0.25	0.28	0.27
d 10 kb	2.72	2.71	2.77	2.85	2.88	2.86	2.86	2.79	2.82	2.85
d 5 kb	2.62	2.61	2.67	2.75	2.78	2.76	2.76	2.69	2.72	2.75
log η	3.8	3.8	3.5	3.0	2.9	3.0	2.8	3.5	3.3	3.1

Same modes of calculations as in Tab. 1. Two sets of densities have been calculated with pressures of 10 and 5 kb. Calculated liquids have hawaiitic, mugearitic, even benmoreitic, not basaltic compositions.

Alkaline centres

1 to 3: oceanic centres.

1. Ile de l'Ouest, Kerguelen archipelago (T.A.A.F.) = benmoreite (recalculated from data in GIRET, 1983; BONIN and GIRET, 1984).

2. Rallier du Baty Peninsula, Kerguelen archipelago (T.A.A.F.) = benmoreite (BONIN and GIRET, 1984).

3. Fayal, Açores = mugearite (data from METRICH et al., 1981).

4 to 7: continental centres.

4. Iskou, Air (Niger) = mugearite (BONIN and GIRET, 1985).

5. Mboutou (Cameroun) = hawaiiite (BONIN and GIRET, 1985).

6. Golda Zuelva (Cameroun) = hawaiiite (BONIN and GIRET, 1985).

7. Ntumbaw (Cameroun) = hawaiiite (data from GHOGOMU et al., 1989).

8. Younger Granite Province (Nigeria) average = mugearite (BONIN and GIRET, 1985).

Tholeiitic and transitional centres.

9. Beinn Chaisgidle, Mull (Scotland) = mugearite (islandite) (data from WALSH and CLARKE, 1982).

10. Iceland = hawaiiite (data from JAUZEIN, 1981).

Tab. 3 Liquids filling up magma chambers in alkaline provinces, calculated from cumulate formations and observed.

	1	2	3	4	5	6	7
SiO ₂	54.04	50.22	50.09	49.53	48.03	47.87	49.7
TiO ₂	1.63	1.74	1.70	1.84	2.20	2.26	3.6
Al ₂ O ₃	16.51	17.65	18.25	18.72	18.16	16.26	15.8
Fe ₂ O ₃	1.50	1.50	1.50	1.50	1.50	2.27	5.0
FeO	7.36	8.37	8.30	8.20	9.29	9.01	8.4
MnO	0.00	0.00	0.00	0.00	0.00	0.13	0.2
MgO	4.50	4.77	4.23	4.28	4.78	6.36	4.4
CaO	6.66	7.51	7.56	8.29	8.86	8.65	6.8
Na ₂ O	3.90	3.87	4.03	3.89	3.42	3.36	3.9
K ₂ O	2.20	1.40	1.23	1.09	0.86	0.94	1.1
P ₂ O ₅	0.44	0.51	0.56	0.64	0.52	0.54	
D.I.	50.8	42.6	43.1	40.6	35.2	34.4	42.2
Mg *	0.44	0.43	0.40	0.41	0.41	0.47	0.34
d 110 kb	2.82	2.87	2.87	2.88	2.92	2.94	2.89
d 5 kb	2.71	2.77	2.77	2.78	2.82	2.83	2.79
log η	3.3	3.0	3.0	2.9	2.7	2.5	3.5

Same modes of calculations as in Tab. 2. Calculated and observed liquids have hawaiitic to mugearitic compositions.

Peloso layered complex, Corsica (France)

1. Quartz-bearing gabbro = mugearite
2. Liquid L4 = hawaiite
3. Liquid L3 = hawaiite
4. Liquid L2 = hawaiite
5. Liquid L1 = hawaiite-basalt

Hawaiitic liquids L1 to L4 have been calculated using volumes and compositions of cumulates and residual liquids at discrete steps of differentiation (PLATEVOET, 1990). Mugearitic quartz-bearing gabbro represents the most evolved liquid in the magma chamber.

Porto ring complex, Corsica (France)

6. Ota gabbro, average of 3 analyses = hawaiite-basalt (PLATEVOET, 1983).

Bjerkreim-Sokndal lopolith, Rogaland (Norway)

7. Fine-grained monzonitic margin = hawaiite (DUCHESNE and HERTOGEN, 1988).

sutitic amphibole in leucogabbro -, the composition of the liquid in which they were formed was estimated (BONIN and GIRET, 1985). The calculated Mg* number ($Mg^* = Mg / (Mg + \text{total Fe})$) of the liquids ranges from 0.43 and 0.32, which corresponds to intermediate composition liquids and which is consistent with the Mg* number of 0.23 computed for liquids filling up the magma chamber evolving under the Iskou ring complex (Tab. 2 analysis 4).

In the Tertiary "granites ultimes" province (Cameroon), bimodal distribution of mafic and felsic rock types has been documented in Mboutou and Golda Zuelva (JACQUEMIN, 1981). However, the "atypical" Ntumbaw complex (GHOGOMU et al., 1989) is made up of major

monzodiorite-monzonite, with minor amounts of syenite-granite porphyry. The least evolved type, a porphyritic monzodiorite (Tab. 2, analysis 7), shows no Eu anomaly and the highest Mg* value found (for example, see Tab. 1 for peridotite-bearing rocks) and, therefore, may represent a composition very close to the parental magma of the complex.

In the Corsican piece of the Permian-Triassic alkaline province of Western Mediterranean (BONIN et al., 1987), few complexes contain mafic rocks. These mafic rocks may be cumulates (Peloso layered complex, PLATEVOET and BONIN, 1985) or may constitute typical net-veined formations with subsolvus biotite granite (Sorba, BONIN, 1980; Ota and other places,

PLATEVOET, 1983, PLATEVOET et al., 1988). Peloso layered mafic rocks have olivine/orthopyroxene, clinopyroxene, apatite, zircon and plagioclase, with minor amounts of amphibole, as cumulus minerals (PLATEVOET, 1990). Observed volumes and compositions of cumulates and residual liquids at discrete steps of evolution have been used for the estimation of the compositions of the different liquids filling up the magma chamber (Tab. 3, analyses 2 to 5). Compared with a quartz-bearing gabbro which represents the most evolved liquid trapped at the top of the cumulate pile (Tab. 3, analysis 1), all computed compositions range from hawaiiite-basalt to mugearite and are consistent with the composition of Ota gabbro which is pillowed by a subsolvus biotite granite in the Porto ring complex (Tab. 3, analysis 6).

The 950 Ma.-old Rogaland anorthositic province of Norway is made up of massive anorthosites, dyke swarms and layered lopoliths (for a review, see DUCHESNE, 1984; DUCHESNE et al., 1985). Magmatic relations between the massive anorthosites, the intermediate monzonorite-jotunite suite and the acidic quartz mangerite-charnockite association are rather complex, as it seems that each piece of the province comes from distinct multiple sources and has experienced different histories.

The small Hydra massif has yielded a fine-grained monzonoritic marginal facies, showing a chondrite-normalized REE pattern without Eu anomaly. Quantitative chemical modeling has shown that this facies could represent the parental magma of the massif. The Bjerkreim-Sokndal lopolith provides additional informations on the nature of parental magmas (DUCHESNE and HERTOGEO, 1988). Multiple replenishments and fractional crystallization processes have produced a series of cumulates from anorthosites to mangerites: plagioclase, orthopyroxene, Fe-Ti oxides, clinopyroxene, apatite and rare olivine compose the evolving cumulus assemblage throughout the entire pile of layered rocks. From Ca, K and trace element contents in plagioclase and apatite, a parental monzonoritic liquid yielding a large La/Yb ratio and no Eu anomaly was calculated. Results from quantitative modeling was later confirmed by the discovery of an occurrence of a fine-grained monzonorite at the contact with the envelope and near the base of the lopolith (Tab. 3, analysis 7). This rock is interpreted as a chilled liquid which at 6–7.5 kb and 1160 °C can crystallize at its liquidus a Fo73 olivine similar to the most magnesian cumulative olivine observed and andesine-labrador plagioclase.

Discussion

There exists a large number of independent evidences that intermediate composition liquids can be produced within the upper mantle and can fill up crustal magma chambers.

This fact, coupled with the scarcity of evidences for primary basaltic liquids differentiating into shallow reservoirs, must be explained in terms of physical parameters of the liquids. Calculations of the physical properties of the magmas have been performed using the GPP (Geochemical Program Package), created by BAKER, MCBIRNEY and GEIST (1985). Densities and viscosities have been computed with a temperature of 1100 °C and 1 wt% H₂O for pressures of 10 kb and 5 kb.

Temperature has been arbitrarily fixed at 1100 °C, because this value corresponds to average mineral-liquid equilibrium temperatures within systematic analytical errors of ± 50 °C for most of the studied examples (e.g. Iskou, LÉGER, 1985; Peloso, PLATEVOET, 1990; Bjerkreim-Sokndal, DUCHESNE and HERTOGEO, 1988).

We have supposed also that mantle-derived magmas are markedly water-deficient. This assumption can be questioned for magmas in which amphibole can crystallize both at mantle depths (GREEN et al., 1974) and in crustal magma chambers (GIRET et al., 1980; BONIN et al., 1987). Thus, because this parameter is strongly dependent of the water content in magmas, the calculated viscosities are to be considered as maximum values for crystal-free liquids.

Finally, pressure values of 10 and 5 kb were chosen because, in within-plate environments, the crust-mantle boundary depth is estimated at about 20–30 km and the average depth of alkaline magma chambers at 10–15 km (BONIN, 1980, 1986). Note that the method of calculation assumes that liquid density increases of about 0.10 g/cm³ for pressure variation of + 5 kb, i.e. that there exists magma compressibility at depths (see MURASE and MCBIRNEY, 1973). Under conditions used for calculations, basaltic and near-basaltic liquids have higher densities (in the range of 2.95–3.00 at 10 kb) and lower viscosities (about 10 + 2.2 poises) than intermediate composition liquids.

Viscosities computed for all compositions (Tabs. 1 to 3) are lower than the critical viscosity for volcanic eruptions, estimated at 10 + 5.5 poises by MARSH (1981), which means that all intermediate composition liquids can be emitted as lava flows at the surface level, providing that they are present in sufficient amounts to be easi-

ly expelled from the magma chamber. Thus, viscosity cannot act as a critical factor.

On the other hand, STOLPER and WALKER (1980) have suggested that density plays a major role in the probability of eruption of lavas. They reported measured densities of experimental products and showed that two groups of compositions display densities lower than the average oceanic crust: basalts and felsic differentiates, while picrites and intermediate composition liquids have higher densities. STOLPER and WALKER (1980) explained this feature by major fractionation of Mg-rich minerals yielding Fe-enriched liquids that are heavier than more primitive ones. Stressing on the bimodality of anorogenic suites and on the density distribution within these suites, these authors concluded that oceanic crust acts as a "density filter", allowing lighter liquids to move up and forcing heavier ones to stay below the crust-mantle boundary, where they can evolve through high pressure fractional crystallization.

In other settings such as continental crust, other density discontinuities are provided at the lower-middle crust boundary, between dehydrated heavy catazonal formations and "wet" light mesozonal formations. Thus, density filters are likely to act at the crust-mantle boundary and within the crust. Average density of the upper mantle is estimated 3.30 g/cm^3 , of the lower crust $2.90\text{--}3.00 \text{ g/cm}^3$ and of the middle crust in the range of $2.70\text{--}2.90 \text{ g/cm}^3$.

The following discussion is based on the assumption that liquids may move up forcefully only because their buoyancy is high. On the contrary, heavy liquids may not move up, unless there is pressure release (causing density decrease) along open fractures propagating upwards in a distensive or extensive stress regime.

A. In this scheme, basalts may reach the surface level in a passive manner only if rift fractures and faults are active. In this case, they are emplaced as lava flows and scoria cones, owing to their low viscosity. In the reverse case, basaltic liquids are trapped below the crust-mantle boundary and are submitted to high pressure fractional crystallization. Intermediate composition liquids are produced at this level.

B. Because they are lighter than the lower crust, intermediate liquids may move up forcefully because of their relatively high viscosity into the catazonal formations to which they provide heat. Heat release provokes crystallization of the magma, which is converted from a near crystal-free liquid into a dominantly crystalline mush. Then, viscosity and density of the overall (liquid + solid ± vapour) magma strongly increase and

cause it to be trapped into a crustal magma chamber, located at the boundary between lower ductile and upper brittle zones (BONIN, 1986).

C. Here, low pressure fractionation processes produce light felsic evolved liquids, which can ultimately move up through open fractures either to the surface level within caldera volcanoes during vapour overpressure episodes, or to the sub-volcanic level of the ring complexes during vapour release episodes (BONIN, 1986). This phenomenon may be repeated several times in the life of a magma chamber.

Thus, four significant structural levels are involved in terms of alkaline magma evolution (Fig. 5):

1. *the upper mantle.* Alkaline magmas, differing in composition from mafic to intermediate, are produced through high pressure (mafic silicate minerals) fractionation from a primary basaltic to picritic magma (GREEN et al., 1974).

2. *the middle crust.* After a forceful way up through lower crust, intermediate composition magmas fill up magma chambers at the ductile-brittle boundary and experience low pressure (mafic silicates + plagioclase + apatite + Fe-Ti oxides) fractionation (DUCHESNE, 1984; LÉGER, 1985; PLATEVOET, 1990).

3. *the shallow ring complex level.* Evolved felsic crystal-free liquids are emplaced passively by cauldron subsidence along mechanical discontinuities within the upper crust. Here, they are chilled and suffer hydrothermal alteration effects during cooling. In some cases, they experience second boiling effects, with pegmatitic pockets and hydraulic brecciation (BONIN, 1988).

4. *the surface level,* characterized by caldera volcanoes. Bimodal magmatic products are emitted, with basalts coming more or less directly from their mantle source and with felsic evolved liquids coming from the crustal magma chamber. Acidic liquids generally experience a strong second boiling effect, causing ignimbrite and pumice explosive eruptions (BARDINTZEFF and BONIN, 1987).

Basalts display characteristics of their source as it is likely that, during their ascent in some days or some weeks, there is insufficient time for major reequilibration between the magma and its wall-rocks. Acidic liquids, on the contrary, have experienced long time reequilibration between volatile-enriched and/or vapour-bearing liquids at the top of the crustal magma chamber and their heated and pervasively altered wall-rocks, located in a convective geothermal system (NORTON, 1978).

Thus can be explained isotopic paradoxes in bimodal magmatism, such as mantle signatures

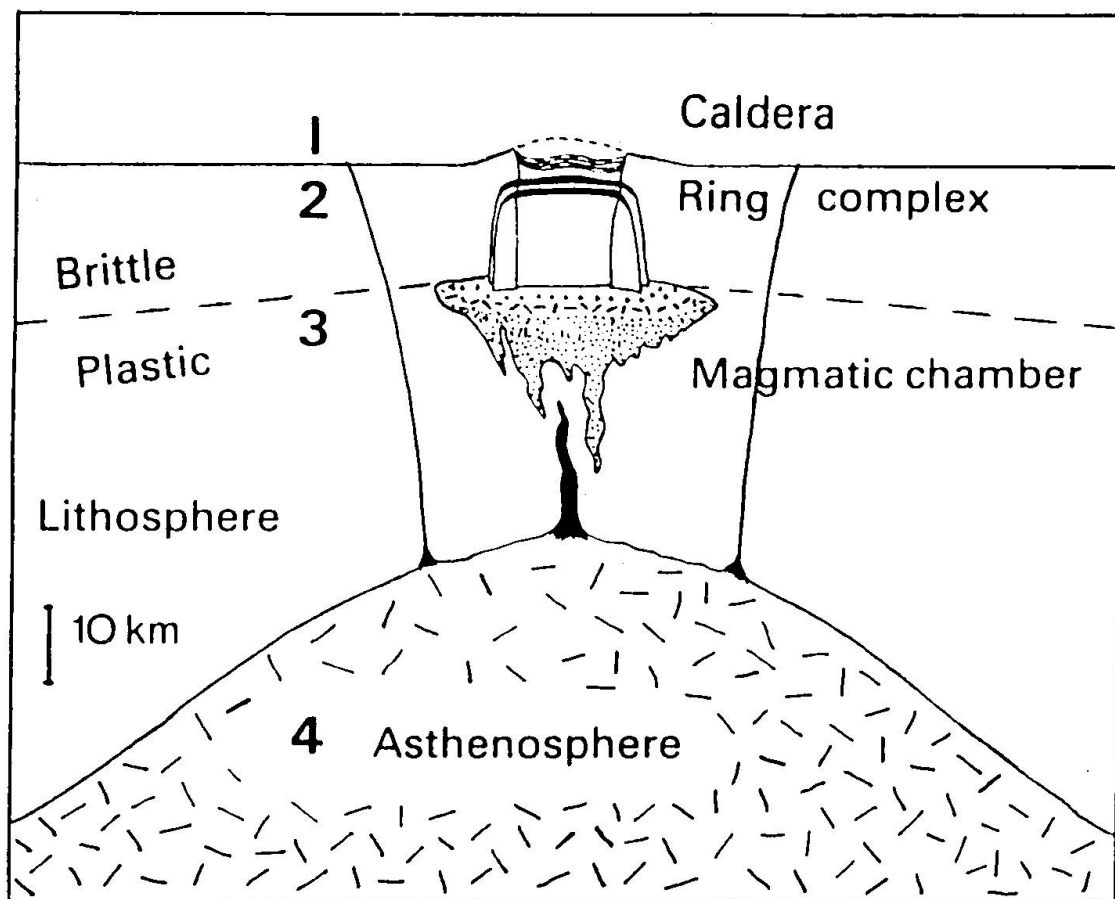

Fig. 5 The four structural levels of the alkaline magmatism (modified after BONIN, 1980, 1986; see text).

for mafic and intermediate compositions and increasingly crustal signatures for felsic compositions, and the large role obviously played by the crust. But it is not necessary to invoke, as classically supposed, crustal partial melting induced by mafic magma intrusion. We favour the hypothesis that hydrothermal F-rich fluids percolating within the middle crust can exert a strong influence, as isotope and trace element so-called "crustal" signatures have been substantiated for both aluminous and peralkaline silicic granite/rhyolite and silica-poor nepheline syenite/phonolite associations (e.g. VAN BREEMEN *et al.*, 1976, for the Nigerian younger granite province; BLAXLAND *et al.*, 1978, for the agpaitic/granitic suite of Gardar, Greenland).

Summary and conclusions

We propose that the Daly gap, classically described in bimodal non-orogenic magmatic associations, corresponds to the original liquids filling up crustal magma chambers. Major lines of evidence are:

1. During a fractionation process, residual liquids and cumulates are produced by a primary magma which subsequently disappears.
 2. Peridotite-bearing intermediate composition magmas are scarce, but do exist in both oceanic and continental settings.
 3. Daly gaps are predominantly intermediate, yielding hawaiitic to benmoreitic compositions.
 4. Alkaline ring-complexes are made up of cumulative mafic rocks and evolved felsic rocks, representing residual liquids.
 5. Mafic cumulates are derived from intermediate composition magmas and not from basaltic magmas.
 6. Some chilled margins of deep seated magma chambers provide evidences for an intermediate composition of the original magma.
- Density is the critical factor. Basaltic liquids are trapped at the crust-mantle boundary, where they experience high pressure fractionation. Intermediate composition liquids are trapped in a crustal magma chamber at the ductile-brittle boundary, where they experience low pressure fractionation coupled with assimilation processes.

At shallow levels, both poorly evolved mafic

liquids and highly evolved felsic liquids are emplaced, associated with some cumulative mafic mega-units carried by intermediate to felsic liquids. Evidences for low pressure fractionation and assimilation can be found in situ in magma chambers emplaced in catazonal to mesozonal crustal formations.

Acknowledgements

This paper is dedicated to the memory of the late Prof. Jean Lameyre, dead on December 7th, 1989. He was the first to have drawn our attention to the possible significance of the Daly gap as a mark of a disappeared original magma, recalling us the old French proverb that "it is impossible to have at once milk and butter".

The senior author thanks very warmly Steve Ayrton and Jean-Clair Duchesne, organizers of the Symposium "Diorites and Associated Rocks", held at Lausanne on September 22nd–23rd, 1989, for having invited and giving him the opportunity to present these thoughts concerning paucity or lack of intermediate compositions in the alkaline magmatic suites. Discussions with people attending the Symposium and with numerous colleagues during varying opportunities have improved our perception of the Daly gap problem.

References

- BAKER, B.H., MCBIRNEY, A.R. and GEIST, D.J. (1985): GPP – A program package for creating and using geochemical data files. Center for Volcanology, Univ. Oregon, Eugene (U.S.A.).
- BARDINTZEFF, J.M., BELLON, H., BONIN, B., BROUSSE, R. and MCBIRNEY, A.R. (1988): Plutonic rocks from Tahiti-Nui caldera (Society Archipelago, French Polynesia): a petrological, geochemical and mineralogical study. *J. Volcanol. Geoth. Res.*, 35, 31–53.
- BARDINTZEFF, J.M. and BONIN, B. (1987): The amphibole effect: a possible mechanism for triggering explosive eruptions. *J. Volcanol. Geoth. Res.*, 33, 255–262.
- BARTH, T.F.W. (1945): The igneous rock complex of the Oslo region. *Nor. Vidensk. Akad. Oslo Skr.*, I, Math.-Nature, KL9, 96–98.
- BATES, R.L. and JACKSON, J.A. (1980): Glossary of Geology, 2nd Edn. A.G.I., Falls Church, Va. (U.S.A.), 751 p.
- BENNETT, J.N. (1981): The petrology and mineral chemistry of the Shira Ring Complex, Northern Nigeria. Ph. D. Thesis, Univ. St. Andrews (Scotland), unpubl.
- BLACK, R. (1965): Sur la signification pétrogénétique de la découverte d'anorthosites associées aux complexes annulaires subvolcaniques. *C.R.Ac. Sc. Paris*, 260, 5829–5832.
- BLACK, R., JAUJOU, M. and PELLATON, C. (1967): Notice explicative sur la carte géologique de l'Aïr à l'échelle de 1/500 000. Ed. B.R.G.M., Paris (France), 57 p.
- BLANCHARD, F., LIOTARD, J.M. and BROUSSE, R. (1981): Origine mantélique des benmoréites de Moorea (Iles de la Société, Pacifique). *Bull. Volcanol.*, 44, 691–710.
- BLAXLAND, A.B., VAN BREEMEN, O., EMELEUS, C.H. and ANDERSON, J.G. (1978): Age and origin of the major syenite centers in the Gardar province of south Greenland: Rb–Sr studies. *Bull. Geol. Soc. Amer.*, 89, 231–244.
- BONIN, B. (1980): Les complexes acides alcalins anorogéniques continentaux: l'exemple de la Corse. *Doct. État ès Sci, Univ. Pierre et Marie Curie, Paris (France)*, 756 p.
- BONIN, B. (1986): Ring complex granites and anorogenic magmatism. *Studies in Geology, North Oxford Academic, Oxford (U.K.)*, 186 p.
- BONIN, B. and BARDINTZEFF, J.M. (1989): Plutonic rocks from Tahiti-Nui caldera (French Polynesia). II. – Evolution of thermodynamical parameters during magma differentiation and emplacement. Application to other alkaline magmatic provinces. *Bull. Soc. Géol. Fr.*, 6, 1091–1099.
- BONIN, B. and GIRET, A. (1984): The plutonic alkaline series: the problem of their origin and differentiation, the role of their mineralogical assemblages. *Phys. Earth Planet. Inter.*, 35, 212–221.
- BONIN, B. and GIRET, A. (1985): Contrasting roles of rock-forming minerals in alkaline ring complexes. *J. Afr. Earth Sci.*, 3, 41–49.
- BONIN, B., PLATEVOET, B. and VIALETTE, Y. (1987): The geodynamic significance of alkaline magmatism in the Western Mediterranean compared with West Africa. In: BOWDEN, P. and KINNAIRD, J.A. eds., *African Geology Reviews*, J. Wiley and Sons, *Geol. J.*, 22, Thematic Issue, 361–387.
- CHAYES, F. (1963): Relative abundance of intermediate members of the oceanic basalt-trachyte association. *J. Geophys. Res.*, 68, 1519–1534.
- CHAYES, F. (1977): The oceanic basalt-trachyte relation in general and in the Canary Islands. *Amer. Miner.*, 62, 666–671.
- CLAGUE, D.A. (1978): The oceanic basalt-trachyte association: an explanation of the Daly gap. *J. Geol.*, 86, 739–743.
- DALY, R.A. (1925): The geology of Ascension Island. *Proc. Amer. Acad. Arts Sci.*, 60, 1–80.
- DALY, R.A. (1933): *Igneous rocks and the depth of the earth*. McGraw Hill, N.Y. (U.S.A.).
- DUCHESNE, J.C. (1984): Massif anorthosites: another partisan review. In: BROWN, W.L. ed., *Feldspars and feldspathoids*, Reidel Publ. Comp., 411–433.
- DUCHESNE, J.C. and HERTOGEN, J. (1988): Le magma parental du lopolithe de Bjerkreim-Sokndal (Norvège méridionale). *C.R.Ac. Sc. Paris*, 306, 45–48.
- DUCHESNE, J.C., MAQUIL, R. and DEMAÏFFE, D. (1985): The Rogaland anorthosites: facts and speculations. In: TOBI, A.C. and TOURET, J.L.R. eds., *The deep Proterozoic crust in the north Atlantic provinces*, Reidel Publ. Comp., 449–476.
- GHOGOMU (1989): The Ntumbaw Complex, NW Cameroon: an atypical anorogenic ring complex of intermediate composition. *J. Afr. Earth Sci.*, 8, 1–9.
- GIRET, A. (1983): Le plutonisme océanique intra-plaque, exemple de l'archipel Kerguelen, Terres Australes et Antarctiques Françaises. *Doct. État ès Sci, Univ. Pierre et Marie Curie, Paris (France)*, 290 p.
- GIRET, A., BONIN, B. and LÉGER, J.M. (1980): Amphibole compositional trends in oversaturated and undersaturated alkaline plutonic ring-complexes. *Canad. Mineral.*, 18, 481–495.
- GISBERT, T. (1989): *Volcanologie de l'île de Tahaa (Archipel de la Société). Son enrichissement en ter-*

- res rares. 3° Cycle Doct. Thesis, Univ. Paris-Sud, Orsay (France), 443 p.
- GREEN, D.H., EDGAR, A.D., BEASLEY, P., KISS, E. and WARE, N.G. (1974): Upper mantle source for some hawaiites, mugearites and benmoreites. *Contrib. Mineral. Petrol.*, 48, 33–43.
- JACOBSON, R.R.E., MAC LEOD, W.N. and BLACK, R. (1958): Ring complexes of the Younger Granite province of northern Nigeria. *Geol. Soc. Lond. Mem. n° 1*, 58 p.
- JACQUEMIN, H. (1981): Contribution de l'étude géochimique des éléments en traces à la pétrogenèse des complexes anorogéniques. Exemple des massifs de Mboutou et de Golda Zuelva (Cameroun). 3° Cycle Doct. Thesis, Univ. Nancy I, Nancy (France), 197 p.
- JAUZEIN, P. (1981): Les granitoïdes des séries tholéitiques sur les exemples d'Islande, de Corse et de la Brévenne. 3° Cycle Doct. Thesis, Univ. Pierre et Marie Curie, Paris (France) 233 p.
- LAMEYRE, J., BLACK, R., BONIN, B., GIRET, A. and PLATEVOET, B. (1982): Coupures dans les suites magmatiques. Le Daly Gap représente-t-il la composition des liquides magmatiques primaires? 9° Réunion Ann. Sci. Terre, Paris, abstr., 354.
- LAMEYRE, J. and BOWDEN, P. (1982): Plutonic type series: discrimination of various granitoid series and related rocks by their modal composition. *J. Volcanol. Geoth. Res.*, 14, 169–186.
- LE BAS, M.J. (1987): Nephelinites and carbonatites. In: FITTON, J.G. and UPTON, B.G.J. eds., *Alkaline Igneous Rocks*, *Geol. Soc. Spec. Publ. n° 30*, 53–83.
- LÉGER, J.M. (1985): Géologie et évolution magmatique du complexe plutonique d'Iskou (Aïr, Niger). *J. Afr. Earth Sci.*, 3, 89–96.
- LÉOTOT, C. (1988): Cycles éruptifs, géochimiques et géochronologiques du Volcan de Taravao (Archipel de la Société). Modèle du hot spot tahitien et de l'alignement de la Société (Polynésie française). 3° Cycle Doct. Thesis, Univ. Paris-Sud, Orsay (France), 365 p.
- MARSH, B.D. (1981): On the crystallinity, probability of occurrence and rheology of lava. *Contrib. Mineral. Petrol.*, 78, 85–98.
- MARTIN R.F. and PIWINSKII, A.F. (1972): Magmatism and tectonic settings. *J. Geophys. Res.*, 77, 4966–4975.
- METRICH, N., BIZOUARD, H. and VARET, J. (1981): Pétrologie de la série volcanique de l'île de Fayal (Açores). *Bull. Volcanol.*, 44, 71–93.
- MURASE, T. and MCBIRNEY, A.R. (1973): Properties of some common igneous rocks and their melts at high temperatures. *Bull. Geol. Soc. Amer.*, 84, 3563–3592.
- NORTON, D. (1978): Sourcelines, source regions, and pathlines for fluids in hydrothermal systems related to cooling plutons. *Econ. Geol.*, 73, 21–28.
- PLATEVOET, B. (1983): Etude pétrologique d'une association acide-basique dans le complexe annulaire anorogénique de Porto (Corse). 3° Cycle Doct. Thesis, Univ. Pierre et Marie Curie, Paris (France), *Mém. Sci. Terre n° 83* 21, 202 p.
- PLATEVOET, B. (1990): Pétrologie des roches basiques et intermédiaires du magmatisme alcalin anorogénique de Corse. Doct. Etat ès Sci., Univ. Paris-Sud, Orsay (France), in press.
- PLATEVOET, B. and BONIN, B. (1985): Le massif alcalin du Peloso (Corse): un complexe lité associé à des monzosyérites. *C.R. Ac. Sc. Paris*, 301, 403–406.
- PLATEVOET, B., BONIN, B., PUPIN, J.P. and GONDOLO, A. (1988): Les associations acide-basique du magmatisme alcalin anorogénique de Corse. *Bull. Soc. Géol. Fr.*, 4, 43–55.
- SHAND, S.J. (1922): The problem of the alkaline rocks. *Proc. geol. Soc. S. Afr.*, 25, 19–33.
- STOLPER, E. and WALKER, D. (1980): Melt density and the average composition of basalt. *Contrib. Mineral. Petrol.*, 74, 7–12.
- STRECKEISEN, A. (1976): To each plutonic rock its proper name. *Earth Sci. Rev.*, 12, 1–34.
- VAN BREEMEN, O., HUTCHINSON, J. and BOWDEN, P. (1975): Age and origin of the Nigerian Mesozoic granites: a Rb–Sr isotopic study. *Contrib. Mineral. Petrol.*, 50, 157–172.
- WALSH, J.N. and CLARKE, E. (1982): The role of fractional crystallization in the formation of granitic and intermediate rocks of the Beinn Chaisgidle, Mull, Scotland. *Mineral. Mag.*, 45, The Deer, Howie, and Zussman Vol., 247–255.

Manuscript received January 30, 1990; accepted March 20, 1990.