

Atomic piles and their use in nuclear physics

Autor(en): **Bretscher, E.**

Objektyp: **Article**

Zeitschrift: **Helvetica Physica Acta**

Band (Jahr): **23 (1950)**

Heft [3]: **Supplementum 3. Internationaler Kongress über Kernphysik und Quantenelektrodynamik**

PDF erstellt am: **24.09.2024**

Persistenter Link: <https://doi.org/10.5169/seals-422260>

Nutzungsbedingungen

Die ETH-Bibliothek ist Anbieterin der digitalisierten Zeitschriften. Sie besitzt keine Urheberrechte an den Inhalten der Zeitschriften. Die Rechte liegen in der Regel bei den Herausgebern. Die auf der Plattform e-periodica veröffentlichten Dokumente stehen für nicht-kommerzielle Zwecke in Lehre und Forschung sowie für die private Nutzung frei zur Verfügung. Einzelne Dateien oder Ausdrucke aus diesem Angebot können zusammen mit diesen Nutzungsbedingungen und den korrekten Herkunftsbezeichnungen weitergegeben werden. Das Veröffentlichen von Bildern in Print- und Online-Publikationen ist nur mit vorheriger Genehmigung der Rechteinhaber erlaubt. Die systematische Speicherung von Teilen des elektronischen Angebots auf anderen Servern bedarf ebenfalls des schriftlichen Einverständnisses der Rechteinhaber.

Haftungsausschluss

Alle Angaben erfolgen ohne Gewähr für Vollständigkeit oder Richtigkeit. Es wird keine Haftung übernommen für Schäden durch die Verwendung von Informationen aus diesem Online-Angebot oder durch das Fehlen von Informationen. Dies gilt auch für Inhalte Dritter, die über dieses Angebot zugänglich sind.

Atomic Piles and their Use in Nuclear Physics

by **E. Bretscher** (Harwell).

The use of the atomic pile as an instrument for the nuclear physicist falls under two headings. Firstly, there are methods which use the chain reacting mechanism of the pile to perform a measurement. Secondly, one can use the pile simply as a source of neutrons.

In order to be able to explain the methods using the pile mechanism, it is useful to summarise the simplest ideas about piles:

1. Physics of a Multiplicative System based on Slow Neutron Fission (Homogeneous System).

(A) *Slowing Down and Diffusion Processes (in the absence of fissile materials).*

When we introduce a fast neutron source into an infinite block of graphite or a large volume of water, we find that the neutrons lose energy by inelastic collisions till they have become thermal. If the moderator used has a low absorption cross section, the thermal neutrons thus produced diffuse through the medium until either they escape or are captured by the moderating medium. We can characterise the first of the two processes, namely, the slowing down process, by a slowing down length, L_s , up to which the neutrons on the average travel till they have reached a specified energy. This length L_s depends on the scattering mean free path, the average cosine of scattering b and the number of collisions N necessary to reach from an initial energy E_i to the final energy E_f . L_s can be obtained from the following relations provided the scattering cross-section is energy independent:

$$L_s^2 = \frac{2l_s}{3(1-b)} N \quad (1)$$

$$l_s = \frac{1}{\Sigma n_i \sigma_i} \quad (2)$$

where n_i and σ_i are number and cross section of the i_{th} atom per cm^3 . If it is assumed that the collisions are symmetrical in the centre of mass system, b depends in a simple manner on the mass

of the atoms making up the medium. N is obtained from the average logarithmic energy loss:

$$N = \frac{1}{a} \log \left(\frac{E_i}{E_f} \right) \quad (3)$$

$$\text{where } a = \left(\log \frac{E_i}{E} \right)_{\text{av.}} \quad (4)$$

and has the value:

$$a = 1 - \frac{(M-1)^2}{2M} \log \left(\frac{M+1}{M-1} \right) \quad (5)$$

To give an example: about 100 collisions are required to reduce the energy of a neutron from 2 MV to 1 eV in graphite, in the course of which it travels about 18 cm from its origin.

It ought to be noted that such elementary considerations are only roughly true since it is assumed that the l_s is energy independent.

After the neutrons have just reached thermal velocity, they will migrate until they are captured. This situation can be described by a diffusion equation, which in the stationary case simply states that the production S of thermal neutrons in a unit volume is just balanced by the absorption of neutrons in the volume (n/τ) and the outflow of neutron current j

$$S = \frac{n}{\tau} + \text{div } j \quad (6)$$

where n is the thermal neutron density at the point, τ the mean life of the neutron, j the neutron current, and S the number of neutrons becoming thermal per cm^3 and sec. If we make the simplest assumption, we can say that $j = -D \text{ grad } n$, where D is a diffusion coefficient which can be shown to be equal to

$$D = \frac{l_s v}{3} = \frac{l_s \cdot l_c}{3\tau} \equiv \frac{L^2}{\tau} \quad (7)$$

If we note that $l_c = \bar{v} \tau$ (l_c capture mean free path) and define a quantity $L^2 = D\tau$, we can write the diffusion equation as follows:

$$\nabla^2 n - \frac{n}{L^2} = - \frac{S}{L^2} \quad (8)$$

(B) *Multiplying Homogeneous Medium.*

We will now apply the above equation to the case of a moderator containing fissile material: in this case the source strength S is proportional to the thermal neutron density. Let us indicate with k the number of secondary neutrons produced when one thermal

neutron is captured. Then we have a source of neutrons $S = kn$ and the above equation becomes:

$$V^2 n + \frac{(k-1)}{L^2} n = 0 \quad (9)$$

Equation (9) is in actual fact incorrect, because we tacitly assumed that the source S emits neutrons which are thermal, but in fact the fission neutrons are fast. It can be shown by a combination of the slowing down mechanism and diffusion theory that L^2 in the above equation has to be replaced by a quantity M^2 , the migration length, obtained in the following manner:

$$M^2 = L^2 + L_s^2 \quad (10)$$

The *pile equation* in its simplest form is therefore:

$$V^2 n + \frac{k-1}{M^2} n = 0 \quad (11)$$

where $\frac{k-1}{M^2}$ is often called the Laplacian λ^2 .

As a solution for a cubical homogeneous pile of length a we obtain

$$n(x, y, z) = N_0 \cos \frac{\pi}{a} x \cos \frac{\pi}{a} y \cos \frac{\pi}{a} z \quad (12)$$

fulfilling the boundary condition that n must vanish at the face of the cube. The critical size a of the pile would result, when the solution (12) is inserted into pile equation (11):

$$\frac{3\pi^2}{a^2} = \frac{k-1}{M^2} \quad (13)$$

N_0 , the number of neutrons at the centre of the cube is arbitrary and determined by the power at which the pile is being run. That (12) is indeed the correct solution and (13) the critical size can be shown by considering the time dependent equation. The general solution then shows that the higher harmonics of the solution die out and only the fundamental remains for stationary piles. We note that the critical size a of a pile increases with the migration length M : a graphite pile has to be larger as the C atoms are poor in slowing down compared to water or D_2O . In addition the neutron balance is more favourable in the D_2O pile as $k-1$ is larger in this case than for a graphite pile; the critical dimension a becomes smaller, therefore, for D_2O than C . These simple considerations are quite important for the experimental physicist who wishes to use a pile as a source of neutrons.

(C) *Time Variation of Neutron Level in a Pile as a Whole.*

If at any moment we have N neutrons in a pile which is not stationary, we have a rate of change dN/dt which is determined by the multiplication and absorption plus loss such that

$$\frac{dN}{dt} = \frac{N(k_e - 1)}{\tau} = \frac{N}{T} \quad (14)$$

$$T = \frac{\tau}{k_e - 1} \quad (15)$$

(T is often called the pile relaxation time, k_e is the effective multiplication constant), so that N increases exponentially if $k_e - 1 > 0$ or decreases for $k_e - 1 < 0$. To give a numerical value let us assume $k_e = 1.01$ and $\tau = 1.5 \cdot 10^{-3}$ sec., this being assumed as the neutron

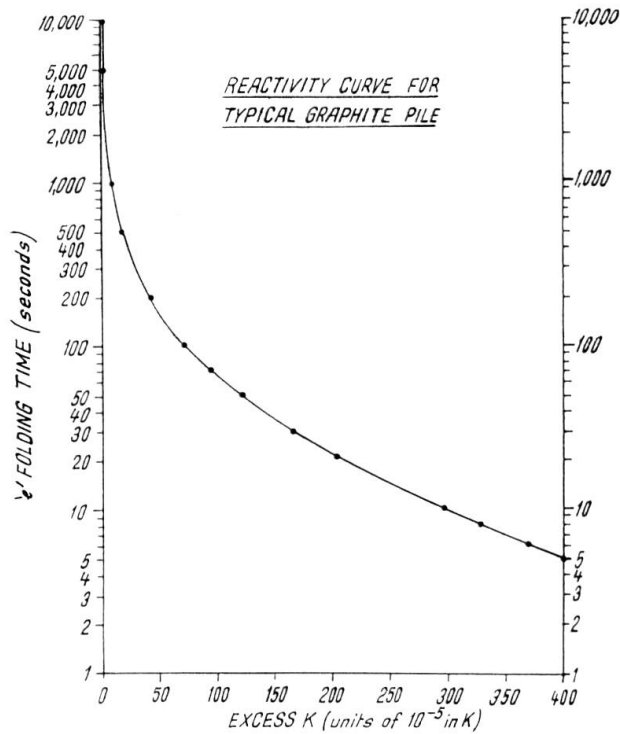

Fig. 1.

Relaxation time of a pile as a function of reactivity $\delta = k_e - 1$.

mean life holding for a graphite pile. With these data, T becomes 0.15 seconds. The pile power will therefore rise with alarming speed. This situation, fortunately, does not occur in practice, because about 1% of the neutrons from fission are delayed and it is in fact they which control for small values of $k_e - 1$ the speed with which the neutron level rises (the longest delayed period is 85 se-

conds). A calculation taking the effects of the delayed neutrons into account gives, instead of (14) ($\delta =$ reactivity):

$$\delta \equiv k_e - 1 = \frac{\tau}{T} + C \sum \frac{\mu_i \tau_i}{T + \tau_i} \approx \frac{\tau + C \sum \mu_i \tau_i}{T} \quad (\text{for } T > \tau_i \text{ maximum}) \quad (16)$$

where C signifies the fraction of all delayed neutrons, μ_i the relative contribution of neutron period τ_i . Obviously, for relaxation times T large to this period the reactivity δ is again inversely proportional to T and this fact makes it very convenient to use the rise time T as a measure of k_e . For this case, with the correct numerical constant, δ becomes $\delta = 2.5 \cdot 10^{-5} / T$ (with T measured in hours) (Fig. 1).

(D) Actual Piles.

A pile of the type described but spherical (the water boiler) is at present in operation in Los Alamos. It consists of a solution of U^{235} dissolved in water, the container being surrounded by a re-

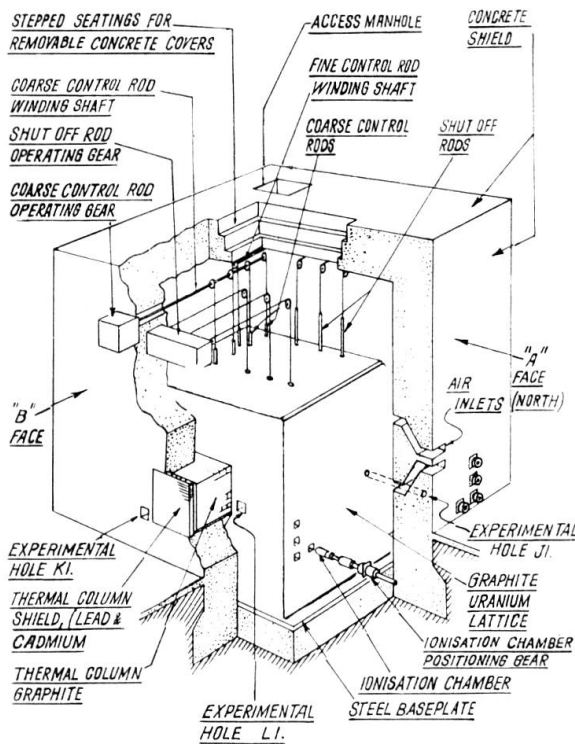

Fig. 2.
Schematic view of Gleep.

flector. Most piles in operation, however, are *inhomogeneous* such as *graphite* or *heavy water* piles. This is done to prevent neutrons in the epithermal energy region from being captured by the U^{238}

since it absorbs strongly above thermal energies and therefore has an unfavourable effect on the neutron balance. I will restrict my remarks to an example, namely, the small experimental pile in HARWELL, called GLEEP (Graphite Low Energy Experimental Pile). It is an assembly of pure graphite through which channels are provided which contain the uranium. This arrangement of a lattice of channels modifies the simple neutron distribution through the pile: the simple cosine-distribution as found in the homogeneous pile is now modulated with periodicity of the lattice. The reacting core is surrounded by a reflector which diminishes the quantities of

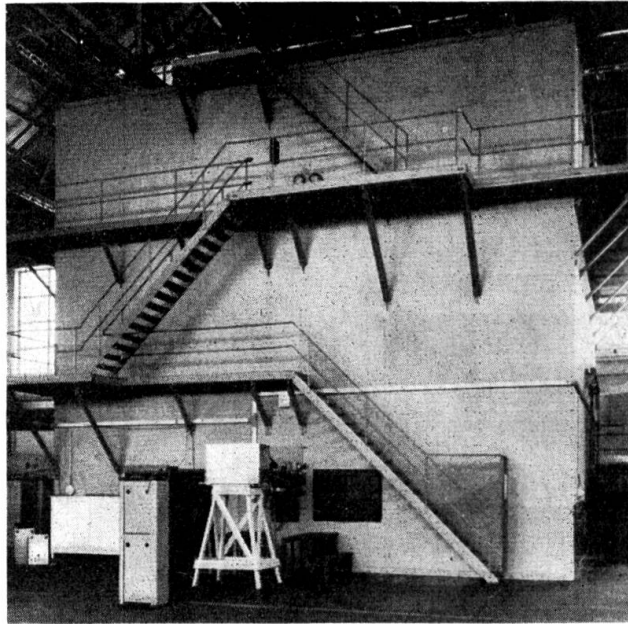

Fig. 3.

Gleep: Pile Face. Experimental hole under stairs with „beam catcher“ in front of it and health monitor in foreground.

metal necessary and increases the average output of power per ton of material. The *control* is obtained by a set of control rods made of heavily absorbing material, and the *neutron level* is measured with the help of boron trifluoride ionization chambers placed at various spots inside the graphite. The *cooling* is achieved by blowing air through the uranium carrying channels. This simple arrangement allows us to go up to 100 kW. design power. The second and larger HARWELL pile, BEPO, has a more effective cooling system which permits the design power to run up to 6000 kW. The Chalk River *heavy water* pile consists of a large tank filled with D_2O into which uranium rods penetrate. The rods are cooled with ordinary water,

a measure which has allowed the design power to reach 10,000 kW. Since the pile dimensions are smaller and the power rather high, it is at present the best pile in existence insofar as neutron flux is concerned.

2. The Use of the Pile as a Measuring Instrument.

Two applications of the pile will be discussed below: (A) the determination of the absorption of a specimen, (B) the absolute calibration of a neutron source with the pile.

(A) Absorption Measurements.

In the past, the pile has often been used to measure the absorption cross section of nuclei for thermal neutrons. The method was first described in a paper by ANDERSON, FERMI, WATTENBERG, WEIL and ZINN, and is often referred to as the "danger coefficient" method. It is based on the fact that the introduction of an absorber into the pile diminishes the reactivity of the chain reacting system. This change can be observed by measuring the relaxation period of the pile (equation (16)). The method serves only to compare absorption, since a calibrating substance, such as boron, has to be used for calibration. The influence on $\delta = k_e - 1$ is proportional to the total absorption of the specimen and proportional to the square of the neutron density, as will be seen in the next section. The sample is therefore placed in the centre of the pile. For the actual performance of the measurement, there are several possible modifications. One way of doing it is the following: the pile power, as indicated by the *B*-ionization chamber current, is allowed to increase slowly by adjusting the control rod. Next a specimen is introduced, so that the power diminishes. The difference of the reciprocal *T*-values is a measure of Δk_e . The procedure is now repeated with the calibrating substance placed at the same positions in the lattice. Boron is generally preferred, since its cross section varies with $1/v$ and has been measured with great precision (FERMI and MARSHALL: $\sigma = 704$ barns for Borax at 2200 m/s neutron velocity).

The method is most reliable with elements of large absorption cross sections. If the specimen scatters strongly, or slows down appreciably, the reactivity is affected even in the absence of absorption (in the opposite sense). For this reason the absorber must be placed in a region of low neutron density gradient, so that the general neutron distribution is not appreciably changed by the insertion of the absorber. FERMI and collaborators have been able to take scattering

and slowing down into account and determined the absorption of beryllium (*loc. cit.*).

One may ask what is the accuracy of such a method? A limit is set by the stability of a pile, namely, the variation of the reactivity of the pile through temperature effects and through the change of barometric pressure: since the X-ray density of graphite is 2.25, the bulk density only 1.6, it is evident that about one quarter of the pile volume is filled with air, disregarding channels. Since molecular nitrogen has a thermal absorption cross section of about 3.4 barns, any change of air pressure will affect the pile reactivity. A change of 10^{-3} atmospheres has the same effect as the introduction of about 1 cm^2 absorber into the centre of the pile.

To improve the pile method of absorption cross section measurements, the *pile oscillator* was invented²⁾. Let us suppose that the

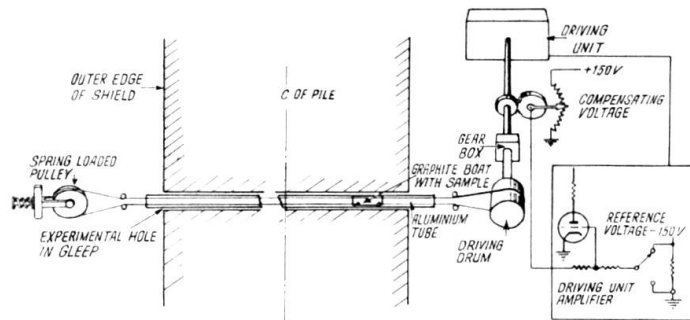

Fig. 4.

Pile oscillator: schematic view.

pile power in the absence of the absorber is slowly rising ($k_e - 1 > 0$) and that the insertion of the absorber has the effect of making the pile power diminish with time ($k_e - 1 < 0$). If we move the absorbing specimen periodically in and out of the pile, a periodic change of the pile power will be brought about, the amplitude being proportional to the total absorption of the specimen. It is obvious that this method avoids, to a great extent, effects due to irregular changes in pile reactivity. They only produce a slow drift of the pile power as read from the ionization chamber current of a recording instrument. This method has the further advantage that the periodic part of the ionization current, which is due to the effect of the absorber, can be amplified by A.C. methods, which introduce considerable simplification of design. Such pile oscillators have been used in the Argonne and Clinton Laboratories in the U.S.A., in N.R.C. Laboratories in Chalk River in Canada, and at A.E.R.E. There are many modifications and considerable refinements of this beautiful method

which, however, are too detailed to be discussed in this review. With the improvements, it is possible with our instrument in Harwell to measure a total absorption cross section of 1 cm^2 with an accuracy of 1% (example: 5 mgr. gadolinium).

(B) *Determination of the Number of Neutrons emitted by a Source.*

Mr. LITTLER³⁾ has recently made experiments to determine with a pile the *absolute number of neutrons* emitted by a *radium-beryllium source*. The method is based on the following considerations: let us consider the case that a pile is just critical, i. e. that the neutron level does not increase or diminish with time. In this case as many neutrons are created per second as are absorbed or escape. Most of the created ones are due to the chain reaction, but a finite number

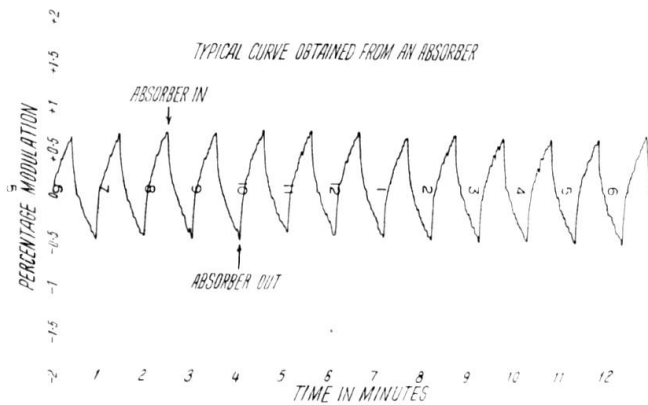

Fig. 5.

Experimental record of periodic part of ionisation current variation due to absorber.

are always produced in the pile through spontaneous fission, α - n processes and cosmic ray effects. The effective reproduction factor k_e is in the stationary state therefore just a trifle below 1. If these neutrons could be cut out somehow, the neutron loss would be greater than production and the neutron level would diminish since $k_e - 1 < 0$. Conversely, if we introduce a neutron source into a steadily going pile, by similar arguments, the neutron level would be expected to increase as a function of time. The situation is, however, a little complicated by the fact that the radium contained in the usual neutron sources has a large neutron absorption cross section which affects the reactivity in the opposite manner. However, the positive contribution of neutron emission is power-independent, whilst the number of neutrons absorbed increases with the neutron level. To eliminate the absorption effect, we make ob-

servations of the change of reactivity for various pile powers and can, in this way, eliminate the absorption effect fairly satisfactorily.

In order to obtain a quantitative result, the following procedure is carried through: a pile, in the steady state, is considered which has a cavity at first empty. Next the source to be calibrated is introduced into the cavity and the balance of the pile disturbed. To obtain equilibrium again, k_e has to be changed by δk_e . A calculation with the two group theory shows how this δk_e depends on the various factors:

$$\delta k_e = \frac{\tau \cdot n^2}{W/n^2 dV} \left(\alpha - \frac{SW}{n} \right) \quad (17)$$

$$\text{where } W = \frac{(\alpha^2 L_s^2 + 1) p}{k_1} \quad (18)$$

where W consists only of known pile constants.

If δk_e as a function of $1/n \sim \frac{1}{\text{power}}$ is determined, the slope of the line thus obtained would give S except for a constant of proportionality. As a rule, n or the power is obtained from the ionization current I in an ion chamber: we therefore write

$$n = BI \quad (19)$$

(17) now becomes:

$$\delta k_e = A \left(\alpha - \frac{SW}{B} \times \frac{1}{I} \right) \quad (20)$$

where A stands for the expression in front of the brackets of (17).

In order to eliminate the constants we make an additional experiment: we determine the effect on k of an absorber which becomes radioactive (δk_A), such as Na or P, when it is brought into the cavity (without source). Next we determine absolutely the number N_0 of active Na or P atoms formed per second at one definite pile power (or ionization current I_0) by standard beta ray coincidence counting methods. Now the effect of the absorber Na or P on k will be:

$$\delta k_A = A \beta \quad (21)$$

and the radioactivity produced is:

$$N_0 = \beta \cdot n = \beta B I_0 \quad (22)$$

where β is the total effective absorbing surface of the Na or P.

Inserting (21) and (22) into (20) one obtains:

$$\frac{\delta k_e}{\delta k_A} = \frac{\alpha}{\beta} - \frac{S \cdot W}{N_0} \frac{I_0}{I} \quad (23)$$

Since W is known, N_0 and I_0 are measured, S the source strength

is obtained from the slope of the straight line, where the left-hand side of equation (23) is plotted against $1/I$.

A consideration of the errors leads one to assess an accuracy of about 6% for this method in the present stage of development.

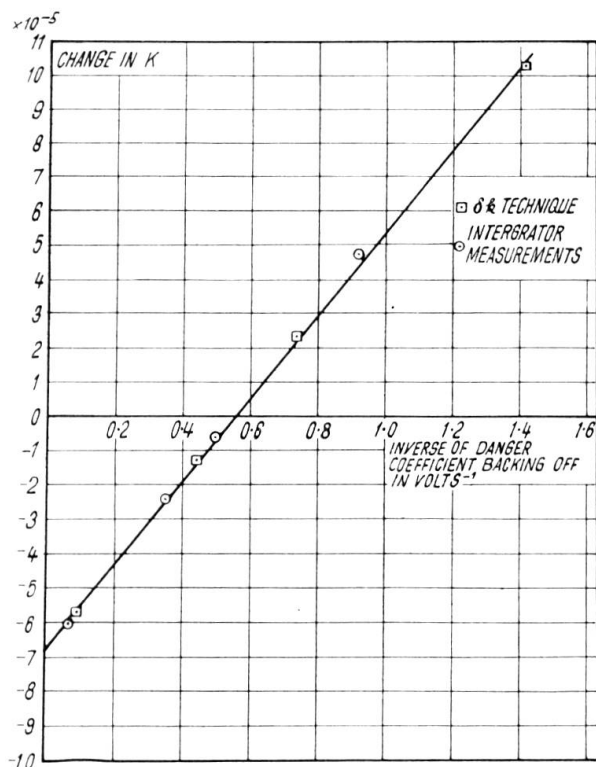

Fig. 6.

Change in k produced by Ra-Be Source as Function of Pile Power.

3. The Pile as a Source of Neutrons.

For many slow neutron experiments, the intensity of the slow neutron beam available is decisive. It may therefore be useful to review the various neutron sources available to the physicist. Let us calculate the neutron flux in the centre of an imaginary pile running at 100 kW.: the number of fissions is roughly $3 \cdot 10^{15}$ per second and the number of neutrons say 10^{16} sec^{-1} . For a pile of say 10 m length, and a neutron life-time $1.5 \cdot 10^{-3} \text{ sec.}$, the neutron density becomes: $10^{16} \cdot 1.5 \cdot 10^{-3} / 10^9 = 1.5 \cdot 10^4$ on the average over the pile. In the centre, however, the neutron density is larger by about a factor 4 over the average. Assuming a velocity of the neutrons of about $2 \cdot 10^5 \text{ cm/sec.}$, the neutron flux becomes: $1.5 \cdot 10^4 \times 4 \times 2 \cdot 10^5 = 1.2 \cdot 10^{10} \text{ n/cm}^2 \text{ sec.}$ In piles running at higher powers it is easy to achieve a thermal neutron flux of say $10^{12} \text{ n/cm}^2 \text{ sec.}$ If

one then allows a canalization factor of $10^{-6} - 10^{-7}$, the beam intensity becomes $10^6 - 10^5$ neutrons/cm² sec., enough for use with crystal spectrometers or velocity selectors.

It should be borne in mind, in this connection, that the experimentally available neutron flux out of a pile does not increase indefinitely with the power of the pile because high power piles have generally cooling mechanisms which absorb reactivity, and this loss of reactivity has to be compensated by making the pile bigger. A considerable factor, however, can be gained by using a heavy water pile instead of a graphite pile as a neutron source, because for a given pile power the volume of the heavy water pile is smaller. I shall return to this matter again at the end of the discussion.

For comparison we may note the fast neutron yields of other frequently used neutron sources: the cyclotron will at best produce a total yield of $10^{12} - 10^{13}$ neutrons from its target; the high voltage set in Cambridge running with 200 μ amps. deuterons on a lithium target with a bombarding energy of 1 MeV provided approximately 3×10^{10} neutrons, whilst ordinary radium-beryllium sources emit 10^7 particles per gram. Though the total number of neutrons is fairly high in a cyclotron, the necessity to slow them down in a moderator leads to a great dilution in neutrons which reduces the fluxes available in the thermal energy region. For thermal neutron beams, the pile remains the superior instrument.

I would next like to survey very briefly the main groups of experiments which have been carried out with the help of piles, without being able to go into the details of these researches.

A. *Experiments requiring Slow Neutron Beams.*

(a) *Neutron spectroscopy.*

The high intensity of slow neutron beams has made it possible to develop a proper neutron spectroscopy⁴). This work, mainly initiated by ZINN at the Argonne Laboratory, has led to a very large amount of information about the variation of the cross section of various nuclear processes of many elements. The set-up at A.E.R.E. is very similar to that published in the Physical Review by ZINN. As a deflecting crystal we use lithium fluoride (100) or calcium fluoride (110) and as a detector a boron trifluoride chamber. It lends itself satisfactorily for the measuring of the total collision area, activation cross section, fission cross sections as a function of neutron energy up to several volts. Though the neutrons are roughly distributed according to a Maxwellian distribution for lower ener-

gies, the higher energy neutron density falls off about as $E^{-3/2}$. This and other factors set a limit to the resolving power $E/\delta E$ which becomes one at about 50 eV in our case.

Equally important is the high intensity of the neutron beam from a pile for velocity selector experiments⁵⁾, as initiated by FERMI and MARSHALL several years ago, and used to determine the all important boron absorption cross section. At higher neutron energies, the modulated cyclotron is at present superior to the pile. The situation, however, may be changed with the development of better mechanical velocity selectors.

I would like to refer to some other experiments which have been done with the slow neutron beams in Chalk River and which were made possible only through the high intensity obtainable there.

(b) *Neutron capture experiments.*

Dr. ELLIOTT⁶⁾ of Chalk River has been able to determine the binding energy of the neutron in heavy hydrogen by measuring the gamma ray emitted when a neutron is captured by a proton. To this end a slab of paraffin wax $25'' \times 25'' \times 5''$ was placed in the thermal column of the pile. The gamma rays emitted were collimated by a conical lead shell and allowed to fall on to a uranium radiator. The electrons ejected were energetically analyzed in a beta ray spectrograph and thus permitted to obtain the energy of the gamma ray. The analysis of the spectrometer curve yielded a value of 2.236 ± 0.005 MeV for the gamma ray, a result which is 50 kV higher than the usually accepted one derived from the photodisintegration of the deuteron. At present Dr. KINSEY, in the same laboratory, is engaged in measuring, with the help of an electron pair spectrograph, the gamma rays emitted when a thermal neutron is captured by carbon and other elements. Clearly, a very large field is thrown open in this case through the high thermal neutron intensity of the pile. Another experiment where the high neutron flux was useful was recently carried out at A.E.R.E. by Mr. FLOWERS⁷⁾, who disintegrated with slow neutrons the He^3 contained in a dilution of 10^6 in ordinary helium. The reaction process is $\text{He}^3 + n = T + H$. The reaction is remarkable for its high cross section of 3700 barns.

(c) *Neutron lifetime experiments.*

The decay of the neutron into a proton and an electron with an energy release of about 800 kV is obviously of the greatest importance and many physicists have thought of means to observe this

phenomenon. At the moment Dr. SNELL at the Clinton Laboratory and Mr. ROBSON of the Chalk River Laboratory are pursuing this problem with great ingenuity. The method is based on the simultaneous observation of the disintegration proton, which is being recorded by an electron multiplier, and the disintegration electron. I believe that at present disintegration protons have been observed which vanish when the slow neutron beam is cut off with a thin boron layer. Experiments of this type seem quite impossible without a high flux pile.

B. *Fast Neutron Experiments.*

Slow-Fast Converter.

The neutrons in a pile consist of a mixture of slow and fast neutrons whose proportion varies according to the position in the pile. For some experiments it is desirable to have as many fast neutrons available as possible. This can be achieved by a converter consisting of a cylinder of uranium metal. About half of the slow neutrons are absorbed by U^{235} which gives rise to fission neutron emission. This inhomogeneous neutron source can be used to study the nuclear properties averaged over a large energy region with the centre of its energy at about 1 MeV. Such experiments were recently carried out by Dr. HUGHES⁷⁾ at the Argonne National Laboratory, and have yielded interesting information about the density and width of levels for a large number of nuclei.

Another, though not very efficient conversion mechanism, is based on irradiating LiD, which leads to the process $Li^6 + n = T + He^4$. The recoiling tritium will occasionally interact with the deuterium because of the large cross section of this reaction according to $T + D = He^4 + n$. Such a mixture placed in a thermal beam of neutrons therefore provides neutrons of energy of about $14\frac{1}{2}$ MeV.

The uranium converter for fast neutrons in a pile has become a most important tool for the study of the changes which occur in the solid body when it is exposed to a fast neutron flux⁷⁾. Under these conditions nuclei are, by collision with the fast neutrons, displaced from their customary positions in the crystal lattice. They may come to rest between crystal planes, a process which leads to changes of practically all the properties of the crystal. Dimensional changes have been observed, changes of the electrical and thermal conductivity, the internal energy of the crystal is altered; some of the electrical properties such as rectifying power and HALL effect are changed in a very spectacular manner by relatively small neutron energy doses. These problems are investigated on both sides of the

Atlantic with great interest partly because of their great practical importance. As an example, Fig. 7 shows how the characteristics of a germanium rectifier are changed by irradiation with the comparatively small dose of 10^{15} neutrons.

C. *Production of Radioactive Elements.*

I have up till now not referred to the immense amount of information which has come about through the large number of radioactive isotopes which a pile produces. I only wish to summarize

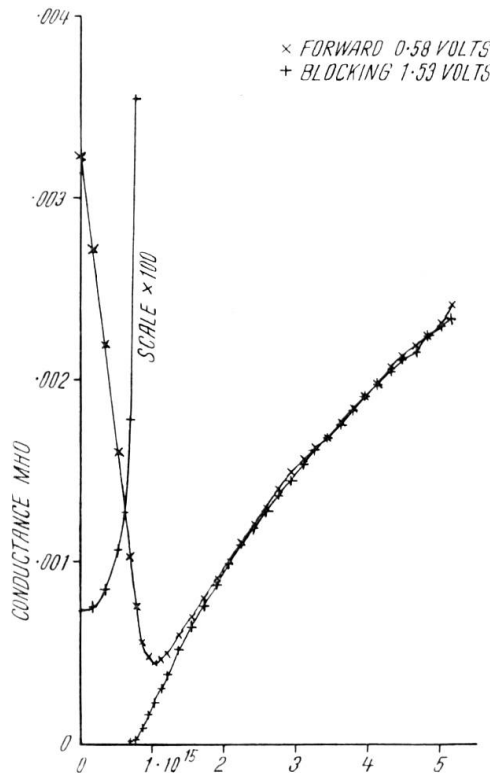

Fig. 7.
Effect of fast neutron irradiation of Germanium Rectifier.
(T. M. Fry - A.E.R.E.)

briefly some of the features which are important to the physicist, especially those working in the field of radioactivity. We have essentially three different ways in which a pile yields material for the physicist:

(a) *Fission products.*

Here the activities available are, for practical purposes, unlimited. However, the extraction and purification requires the chemical processing of pile uranium, which can, because of its enormous activity,

only be done in specially equipped laboratories. Many operations have to be performed by distant control mechanisms and extensive shielding for the protection of the workers has to be provided. In this manner thousands of curies of activity can be handled. It is in the nature of the processes leading to their production that the fission products are free from stable isotopes, therefore of very high specific activity and suitable for beta ray work.

(b) *Carrier free isotopes.*

These products are produced, as a rule, by $n-p$ and $n-\alpha$ reactions or by $n-\gamma$ reactions with a successive beta decay. The substance mostly in demand from A.E.R.E. is I^{131} produced from tellurium, from which it can be isolated chemically. The amounts available are usually determined by the effort required to process the large amounts of tellurium and are not by restrictions through the pile. The specific activity is high and it is at present being marketed in a solution containing 10 m. curies/cm³. The total production at present is 700 mc. per week. The other radio-element which is very much in demand is P^{32} , obtained by extraction of irradiated sulphur. About 0.5 curie is being despatched per week at present, but much more could be made if necessary. This source can be made practically carrier free. In some cases the SZILARD-CHALMERS method has been successful, such as the preparation of Fe^{55} and Fe^{59} , by extracting irradiated ferrocyanic acid.

(c) *Isotopes produced by neutron capture.*

The activities obtainable depend on the cross section for neutron absorption and the neutron flux. The activity per gramme of material is naturally very much smaller than in the cases (a) and (b), since the material consists mostly of inactive isotopes, but the total activity of specimens can easily go into 1—10 000 curies as in the case of sodium and cobalt. One example is *radio sodium*, which interests the physicists as a source of gamma rays for nuclear photo-disintegration experiments, is made with specific activity of 0.4 curies per gramme in the bigger HARWELL pile. Obviously much higher specific activity could be obtained in Chalk River. One of the acute problems of such sources is caused by the safety regulations which allow, at present, only 20 millicuries to be transported on the plane.

I would like to add finally a few words about production of one of the most desirable pile products, namely *tritium*, and its decay product He^3 . In order to use the neutrons in a pile economically,

materials with large absorption cross sections have to be placed into the reflector where the neutrons, many of which anyway escape from the reacting core, can still be used up. The reduced flux in the reflector, however, necessitates the processing of larger amounts of materials than if the material had been put into the centre of the pile. In order to produce one litre of tritium per year we would have to process eventually about 80 kilos of lithium salt, a problem which the members of the Isotope Division of HARWELL do not consider very favourable. For this reason, tritium and its decay product He^3 will not, in our Establishment, be very abundant in the near future.

D. *Production of Transuranium Elements.*

The production of the transuranium element plutonium on an industrial scale is perhaps the most spectacular result of the pile development. It has received so much publicity that a few words will suffice. To appreciate the size of the task I have only to mention that one megawatt-year pile power produces about 400 gr plutonium. The amount of energy to be disposed of, is therefore enormous. To this has to be added the effort to process chemically the exposed uranium: to extract the plutonium under radiation intensities which run into $10^5 - 10^6$ curies.

E. *Higher Order Reactions.*

For the physicist great interest attaches to the possibility to produce by successive incorporation of several neutrons new radioactive bodies. Such processes have been observed in many cases, but I will refer only to the example of I^{131}

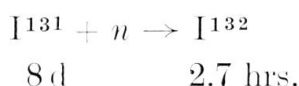

for which at Chalk River a cross section of 420 barns has been found.

The transuranium elements curium and americium furnish further interesting cases. Since the formation of these elements depends on $(nvt)^m$, where nvt is the neutron dose, and m the number of neutrons incorporated, the high neutron density becomes a pre-requisite for its formation.

F. *Neutrino Experiments.*

The high rate of β -processes occurring at any time in a going pile gives rise to the emission of a large number of neutrinos. If we take our example of a cubic pile of 10 m length and a pile power of

10^4 kW, one obtains about $7 \times 3 \cdot 10^{17} = 2,1 \cdot 10^{18}$ neutrinos per second (7β processes per fission). Per cm^2 of pile surface, this represents a flux of $3,5 \cdot 10^{11}$ neutrinos per second. Since this flux extends over a large area, there is a chance to observe inverse beta- processes in large volumes of matter. Dr. PONTECORVO is at present planning such an experiment.

4. Future Possibilities.

It may be asked in which direction future development may be expected from the physicist's point of view. In the first instance, the research worker wants higher neutron fluxes and more powerful neutron beams. To achieve this the number of fissions per second in the uranium slugs has to be increased, or technically the number of megawatts per ton of metal raised. It is obvious that with present constructions there is a limit, as the traditional cooling mechanism becomes too inefficient. Reactors are in the design stage in various places which will be more powerful. On the whole this matter rests in the hands of the engineers and metallurgists. Great uncertainty in all such planning lies in the fact that little is known about the behaviour of constructional materials under neutron bombardment. This is one of the cardinal problems which has to be solved with the help of high flux experimental reactors.

One attractive suggestion of a physics tool, the so-called *Dragon*, has been made by Professor FRISCH. It is based on a fast reactor which can be made supercritical for prompt neutrons for a short period only. One might have a cylinder of pure plutonium with a hole through it. It would be of such size that it would be subcritical and a plug could be shot at great speed through the hole, making the system for a short period supercritical. Since the neutron lifetime in such an assembly may be of the order of 10^{-8} seconds, a very large multiplication would take place during the passage of the slug through the hole. This burst of neutrons could serve for time-of-flight experiments, extending over a large distance, say 100 m. The burst could last 10^{-4} sec. and yield 10^{15} neutrons, producing at a distance of 100 m still a neutron flux of 10^7 . This method would permit the study of neutron properties up to several times 10^4 eV, a region which is still rather inaccessible.

Bibliography.

¹⁾ *Absorption Measurements.* H. L. ANDERSON, E. FERMI, A. WATTENBERG, G. L. WEIL, W. H. ZINN, Phys. Rev. **72**, 16 (1947).

²⁾ *Pile Oscillator. Theory:* A. M. WEINBERG and H. C. SCHWEIDLER, Phys. Rev.

74, 851 (1948). *Experimental*: J. I. HOOVER, W. H. JORDAN, C. D. MOAK, L. PAR-DUE, H. POMERANCE, J. D. STRONG, E. O. WOLLAN, Phys. Rev. **74**, 864 (1948).

³⁾ *Neutron Source Calibration*: D. J. LITTLER. In course of preparation for publication.

⁴⁾ *Neutron Spectroscopy. Crystal Spectrometer*: W. H. ZINN, Phys. Rev. **71**, 752 (1947); W. J. STURM, Phys. Rev. **71**, 757 (1947).

⁵⁾ *Velocity Selector*: E. FERMI, J. MARSHALL, L. MARSHALL, Phys. Rev. **72**, 193 (1947); T. BRILL, H. V. LICHTENBERGER, Phys. Rev. **72**, 585 (1947).

⁶⁾ *Neutron Capture by Protons*: R. E. BELL, L. G. ELLIOTT, Phys. Rev. **74**, 1552 (1948); *Neutron Life Time*: A. H. SNELL, L. C. MILLER, Phys. Rev. **74**, 1217 (1948).

⁷⁾ *Fast Neutron Experiments. Nuclear Physics*: D. J. HUGHES, W. D. SPATZ, N. GOLDSTEIN, Phys. Rev. **75**, 1781 (1949); *Effects on Solid Body*: "Effect on neutron bombardment on order in the alloy Cu₃Au". Sidney Siegel. AECD-2465 (1949); Also Phys. Rev. **75**, 1823 (1949); "Nucleon bombarded germanium semi-conductors" Lark-Horovitz and others, AECD-2054; "Neutron irradiated semi-conductors" W. E. JOHNSON and K. LARK-HOROVITZ, Phys. Rev. **76**, 442 (1949).