

MPLS traffic engineering : the enabler of true network convergence

Autor(en): **Genoud-Voigt, Carine / Lamti-Ben-Yacoub, Leila / Schmid, Andreas**

Objektyp: **Article**

Zeitschrift: **Comtec : Informations- und Telekommunikationstechnologie = information and telecommunication technology**

Band (Jahr): **80 (2002)**

Heft 2

PDF erstellt am: **20.06.2024**

Persistenter Link: <https://doi.org/10.5169/seals-877179>

Nutzungsbedingungen

Die ETH-Bibliothek ist Anbieterin der digitalisierten Zeitschriften. Sie besitzt keine Urheberrechte an den Inhalten der Zeitschriften. Die Rechte liegen in der Regel bei den Herausgebern.

Die auf der Plattform e-periodica veröffentlichten Dokumente stehen für nicht-kommerzielle Zwecke in Lehre und Forschung sowie für die private Nutzung frei zur Verfügung. Einzelne Dateien oder Ausdrucke aus diesem Angebot können zusammen mit diesen Nutzungsbedingungen und den korrekten Herkunftsbezeichnungen weitergegeben werden.

Das Veröffentlichen von Bildern in Print- und Online-Publikationen ist nur mit vorheriger Genehmigung der Rechteinhaber erlaubt. Die systematische Speicherung von Teilen des elektronischen Angebots auf anderen Servern bedarf ebenfalls des schriftlichen Einverständnisses der Rechteinhaber.

Haftungsausschluss

Alle Angaben erfolgen ohne Gewähr für Vollständigkeit oder Richtigkeit. Es wird keine Haftung übernommen für Schäden durch die Verwendung von Informationen aus diesem Online-Angebot oder durch das Fehlen von Informationen. Dies gilt auch für Inhalte Dritter, die über dieses Angebot zugänglich sind.



Exploration Programmes:
Corporate Technology Explores Future Telecommunications

MPLS Traffic Engineering: The Enabler of True Network Convergence

MPLS Traffic Engineering is a new trend for network optimisation and service assurance. It enables service differentiation necessary for the transport of multiple applications requiring several Quality of Service levels over a common IP platform. We evaluated MPLS Traffic Engineering features in their early stage of deployment in an experimental test-bed. Based on the achieved results, the use of MPLS Traffic Engineering for the implementation of a Virtual Leased Line service is proposed as a cost-effective alternative to classical leased lines, a step towards true network convergence.

The Exploration Programme "IP Business Support Issues" deals with technologies, services and support functions for IP networks. In detail, these are:

- Content-oriented IP billing; technologies needed to charge for IP services.
- MPLS Traffic Engineering; how to enable the support of IP Service Level Agreements (SLA) with end-to-end QoS guarantees.
- Fraud; what kind of fraud is to be expected when offering services on IP networks and how to prevent it.
- Security of mobile devices; what privacy services can be offered considering that GPRS and UMTS will make mobile devices accessible from the Internet.
- Security services for the mass market; easy-to-use security services for Internet users.

With its Exploration Programmes, Corporate Technology is exploring telecommunication technologies and new service possibilities with a long-term view of 2-5 years. Furthermore, the expertise built up in the course of this activity enables active support of business innovation projects.

Presently, the majority of network operators do not deploy MPLS TE (Traffic Engineering) techniques since they rely on the over-dimensioning approach. This is reasonable in the cur-

CARINE GENOUD-VOIGT,
LEILA LAMTI-BEN YACOUB AND
ANDREAS SCHMID

rent situation where backbones are largely under-utilised and considering that over-dimensioning is the simplest, easiest and therefore cheapest approach to operate.

However, this situation is changing with the introduction of highly demanding and mission-critical services asking for guaranteed and differentiated QoS levels.

The Swisscom IP network implements MPLS as the forwarding/switching technique. One of the main incentives for the use of MPLS in carrier networks is traffic engineering. For this reason, the goal of the project run at Swisscom Corporate Technology was to evaluate MPLS TE on two axes:

- a technical study: analysis and testing of the different MPLS TE features
- a business study: proposal of implementation scenarios for services requiring MPLS TE in the Swisscom MPLS/IP core network

A family of services enabled by MPLS TE and gaining popularity among providers and customers are point-to-point "leased

line like" services over IP networks. They are built by the transport of any layer-2 protocol such as Ethernet, Frame Relay (FR) and ATM in a point-to-point fashion across an MPLS network. We call them Virtual Leased Line (VLL) services. They offer guarantees on end-to-end QoS and on bandwidth and could be considered as a cost-effective alternative to classical leased lines.

The VLL service enhances the existing leased line service by adding more flexibility in terms of bandwidth, QoS and protection schemes. Customers are given the choice to assemble these components on their own while gaining significant price reductions for lower quality services. Consequently, the VLL service addresses not only existing, but also new markets such as the SME market with a limited networking budget.

MPLS Traffic Engineering: General Overview

MPLS introduces a new forwarding paradigm to IP networks and brings connection-oriented properties through the Label Switched Path (LSP) concept. Labels are assigned to the packets at the ingress node to specify their path and priority. The label is 20 bits wide, with 3 additional bits for the EXP (experimental) field. This EXP field is used for Class of Service (CoS) signalling to indicate packet treatments in the core routers, such as queuing and scheduling. Routers that support MPLS are called Label Switching Routers (LSR).

MPLS TE techniques have been designed to optimise the routing of IP traffic. Constraint-Based Routing (CBR), defined in RFC 2702 [1], is the TE mechanism that

computes a feasible path in an IP network based on a traffic description and a set of constraints. The calculated path fulfils the constraints and is optimal with respect to some scalar metrics. Different constraints in the tunnel setup request such as bandwidth, jitter and delay can be used.

In a MPLS TE network, a CBR system is built up from three components:

- a forwarding mechanism: the MPLS protocol
- a path selection algorithm (taking into account the constraints): a CBR mechanism
- an LSP setup mechanism (to reserve an LSP): the Constraint-Based Routing Label Distribution Protocol (CR-LDP) and the ReSource reservation Protocol with Traffic Engineering extensions (RSVP-TE)

The second component (path selection) is based on enhancements of the traditional routing protocols used in classical IP networks. The IETF has defined extensions to the commonly used IGP protocols, OSPF and IS-IS, in [2] and [3]. This allows CBR to consider not only the topology of the network but also the attributes of the LSP and the links for the path selection process. In the following, we describe the behaviour of the CBR algorithm (also summarised in fig. 1).

CBR is performed by the ingress router. First, the router receives TE information from a link state IGP enhanced protocol (1 in fig. 1). The following information is needed to compute a path:

- network topology
- resource availability
- link attributes

This information is stored in the Traffic Engineering Database (TED) (2 in fig. 1). Then, CBR computes a path which has enough bandwidth and respects the constraints from the tunnel setup request. The computed path is given back as an explicit route consisting of a sequence of IP addresses (3 in fig. 1). This explicit route is then sent to the path setup mechanism (4 in fig. 1) which is used to reserve capacity for the tunnel and to setup the LSP.

For scalability reasons trunks can be defined in the MPLS core. A traffic trunk is a collection of flows (i.e. LSPs) that share the same CoS and the same path. If the number of flows (traffic) increases, the number of trunks will not increase and therefore the control traffic will not be higher.

Compared to classical IP routing, which can cause over-utilisation of some links

while others remain under-utilised, the load is better balanced in an MPLS TE enabled network. Hence, congestion is avoided, packet loss and transit delay decrease, whilst the throughput increases.

The most important features supported by MPLS TE are:

1. Protection/Restoration

A backup tunnel path is planned to either protect a single tunnel or a single physical link in the network. The following alternatives are distinguished:

- *Protection*: the backup path is computed and reserved for a specific tunnel/link, so that in case of failure, the re-routing to the new path is done very fast (in the range of tens of milliseconds).
- *Restoration*: a mechanism exists to calculate a backup path in case of failure. This process can take several seconds or minutes depending on the number of tunnels affected by the failure. Also, the risk of not finding a path answering the requirements of the tunnel exists.
- *MPLS fast re-route*: this is an in-between solution between protection and restoration. It provides link protection by re-routing MPLS TE tunnel traffic onto a planned backup tunnel when a link fails. When the router detects the link failure, it locally patches the primary tunnel traffic to the backup tunnel in a fraction of a second (approx. 50 ms). This fast

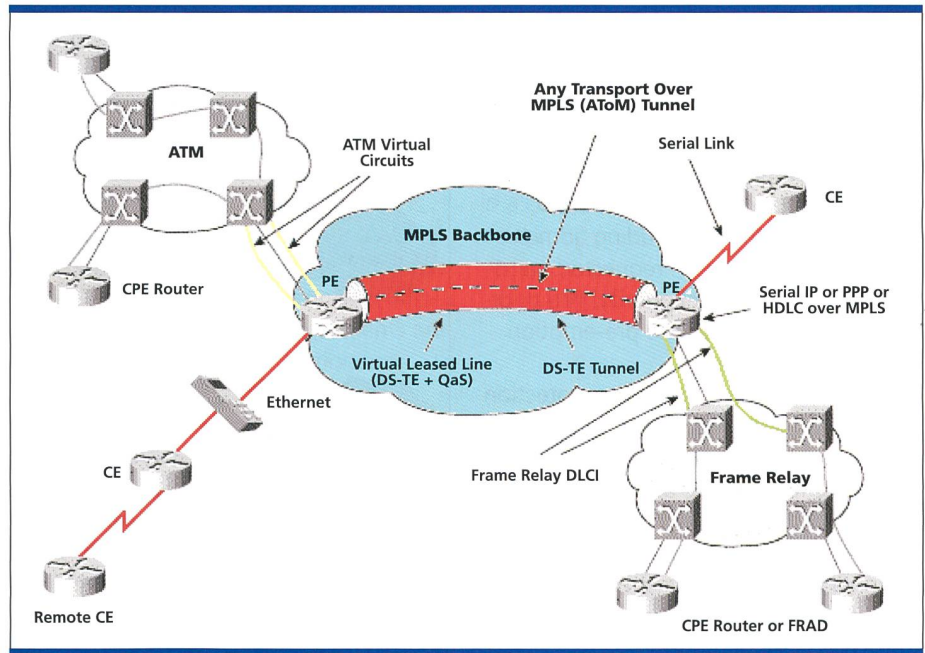

Fig. 2. Virtual Leased Line service model.

re-route feature is done on an aggregate level. This means that all tunnels passing a specific link (and configured for the MPLS fast re-route feature) are re-routed on only one backup tunnel. This aggregation makes the solution scalable.

2. DiffServ-aware TE

Differentiated Services (DiffServ) can be used to give relative priority treatment to different Classes of Service. With the IETF DiffServ framework, network traffic is

classified at the edge and divided into different CoS based on the QoS requirements of a traffic flow. Packets are marked with DiffServ Code-Points (DSCP) according to their defined service categories. Then, the core nodes use differentiated per-hop forwarding behaviours by looking at the DSCP in the packet header. In a DiffServ-aware MPLS TE network, when a packet arrives at an LSR, the label as well as the EXP field can be used to determine the type of treatment. A packet is assigned to a specific LSP tunnel using the EXP field in two ways: either by just using the EXP field or by using the EXP field together with the MPLS label for CoS differentiation.

Test Results

An experimental topology has been set up in order to evaluate MPLS TE functionality, its current status of implementation and its performance. The lab setup consisted of five Cisco routers (three core routers, Cisco 12016, and two edge routers, Cisco 7206VXR). For traffic generation and performance measurements, we used a Spirent SmartBits 6000 traffic generator. The tests were performed based on a basic configuration covering the requirements for MPLS TE (such as preparing all routers and router interfaces for MPLS TE and enabling the IGP extensions – IS-IS in our case – for the support of MPLS TE). There were the following four classes of tests:

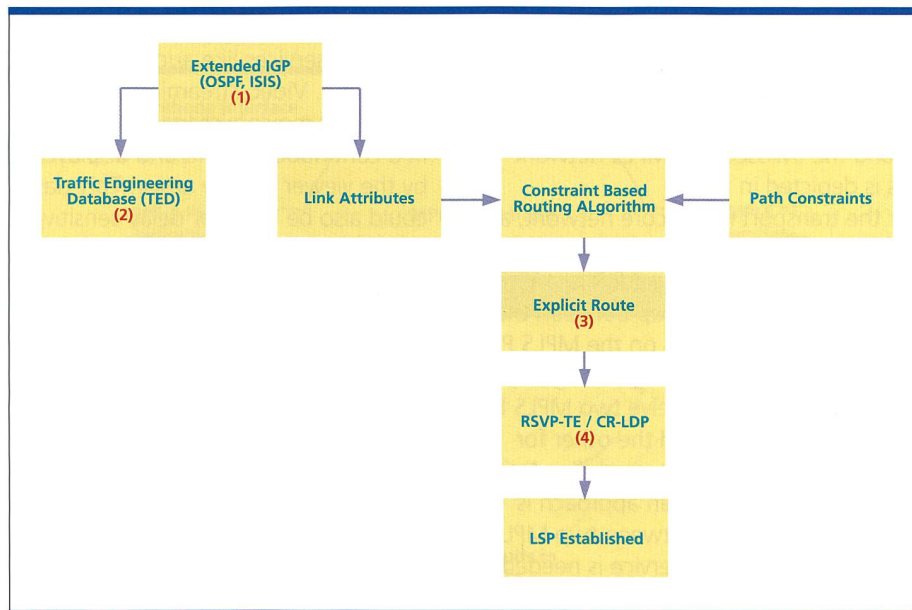

Fig. 1. Constraint-Based Routing operations.

- *Routing control*: including CBR routing, strict source routing (using a specific explicit path for a tunnel), loose source routing (specifying which hops to exclude from a tunnel path), link attributes (specifying which link types can be used for a specific tunnel).
- *Admission control*: including admission control based on requested bandwidth and on tunnel priority. The priority attribute enables the pre-emption mechanism.
- *Resilience control*: including protection and restoration mechanisms, as well as local protection using the MPLS TE fast re-route feature (see above).
- *Capacity management*: including Diff-Serv-aware MPLS TE and automatic tunnel bandwidth adjustment.

More details on the test run and the results can be found in [4]. The tests showed that some of the MPLS TE features are not yet ready for implementation in an operational environment while others are already quite mature. The following features can be considered as mature:

- Routing control (without too many dynamically routed tunnels)
- Admission control
- Resilience control (although massive introduction of dynamic path protection/restoration schemes results in slow restoration)

Our conclusion of the tests is that the use of basic MPLS TE features could solve some specific operational problems IP networks engineers face in their daily business. Other features like automatic bandwidth adjustment and DiffServ-aware MPLS TE are not yet ready for full implementation.

MPLS TE Service Scenario: The VLL Service

As opposed to the leased line services offered presently to Swisscom business customers based on multiple platforms, the *Virtual Leased Line (VLL)* service would lead to reduced operational costs and would fit into the strategy of a unique platform for multiple services. The VLL solution has several advantages. First, offering layer-2 services over MPLS will allow to offer ATM and FR services at a potentially lower price. This is due to operational cost reduction, since all layer-2 services will be transported over the same IP backbone. Second, the migration of FR and ATM services on an IP platform is interesting for customers

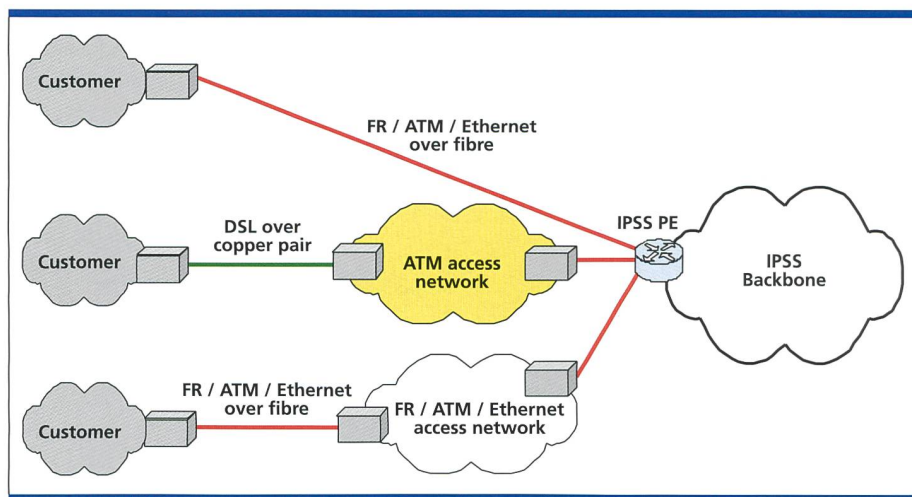

Fig. 3. Virtual Leased Line access solutions.

using such protocols only for the transport of IP traffic. Moreover, Ethernet over MPLS is a service that allows the extension of VLAN domains without using expensive equipment. Fig. 2 summarises the possible use of the different VLL services for customer networks.

Technical Implementation

In this article, we only consider VLL services with bandwidth values greater than 2 Mbit/s. This is because leased line usage is migrating to higher speeds as enterprise and carrier traffic increases and as prices continue to fall [5]. For the access of the VLL service, three solutions in the transmission media area have been identified:

- a copper pair using DSL technologies
- a direct fibre connecting the customer directly to the Swisscom IP/MPLS network Provider Edge (PE) router
- a fibre connecting the customer to an existing access network

The connectivity between the end customer and the Swisscom IP/MPLS network PEs is depicted in fig. 3.

For the transport in the core network, an MPLS TE tunnel is set up between the two MPLS PE routers. In addition, a Virtual Channel (VC) is set up between the two customer interfaces on the MPLS PE router. The packets passing through the MPLS backbone will receive two MPLS labels, one for the VC and the other for the aggregate MPLS TE tunnel (fig. 4). The advantage of such an approach is that only one tunnel between two MPLS PE routers per class of service is needed. Multiple VCs can be tunnelled through a single PE-PE tunnel. This hierarchy makes the solution scalable.

The VLL Service Model

In order to efficiently transport all kinds of traffic using VLL, four classes of service with different QoS values have been defined. For all the classes, the amount of bandwidth is guaranteed and fixed in the customer contract. The four classes are as follows:

- *Platinum*: offers the most stringent requirements in terms of QoS. The supported quality allows to transport interactive real-time services such as voice over IP, video conferencing over IP, etc. The QoS parameters have been chosen so that the perceived (subjective) quality for voice and video by the customers is very good. The end-to-end values have been chosen according to an ITU-T study [6] as follows: delay ≤ 70 ms, packet loss $\leq 10^{-4}$ and jitter ≤ 10 ms.
- *Gold*: used to transport non-interactive real-time services like audio and video streaming. Video streaming is a sequence of moving images that are sent in a continuous stream and displayed by the viewer as they arrive. This class could also be used for delay-sensitive business applications like SAP or others. The QoS parameters have been chosen according to [7] and are as follows: delay ≤ 400 ms, packet loss $\leq 1\%$ and jitter ≤ 50 ms.
- *Silver*: used for interactive burst transfer services like www, telnet or ftp. Jitter is not important for this kind of applications. The QoS values have been chosen according to [7] and are as follows: 500 ms \leq delay \leq 2000 ms and packet loss $\leq 7\%$.
- *Bronze*: commits an amount of bandwidth but does not give any guaran-

tees on delay, jitter or packet loss. Since only bandwidth is guaranteed, it can be considered as a better than best effort service.

We propose that the QoS parameters described above are guaranteed with an availability of 99,99%, where the service shall be considered "unavailable" when one of the three QoS parameters characterising a specific class is not respected.

The Protection Model

To achieve the service availability agreed in the SLA (99.99%), the network has to handle two main possible network failures. The first corresponds to congestion and the second to breakdowns in the access and/or core networks. MPLS TE features are used to better balance the load and hence to avoid congestion. The second problem can be split into two parts: the access and the core. In case of failure in the access, especially after a fibre break, the Mean Time To Repair (MTTR) is about 48 hours [8]. To protect the service, a dual access at the customer side could be offered (e.g. 2 physical connections are used to connect the customer to the first PE). In case of failures in the core, MPLS TE resilience schemes defined above (General Overview) could be used. In order to choose a specific resilience mechanism, we assume that a single trunk between two PEs is used to multiplex the traffic of different VLL services belonging to the same CoS. We consider the three CoS which have stringent requirements in terms of QoS (Platinum, Gold and Silver). Using the described protection mecha-

nisms for all the tunnels, i.e. creating and reserving backup paths for all the tunnels, is very complex, not scalable, and results in huge capacity wastage. An alternative solution would be to use the restoration mechanism for the three classes, i.e. a dynamic backup tunnel is only planned (not reserved) so that it will be computed in case of failure. Since this process can take several seconds or minutes, the platinum class requirements are violated. To extend its protection, we propose to use the MPLS fast re-route feature on all the network links where platinum tunnels pass.

Conclusions

MPLS Traffic Engineering offers an adaptive behaviour to the network in case of failures or traffic load shifts. It also offers the opportunity for service differentiation and supports the transport of multiple services over a common IP platform. A service enabled by MPLS TE is the VLL service, a cost-effective alternative to classical leased lines. The use of basic MPLS TE features could solve some specific daily operational problems. For example, using tunnels for a set of traffic flows allows to split the traffic distribution on core router interfaces according to the source and destination nodes. This provides valuable information for network link capacity upgrade decisions.

Outlook

GMPLS (Generalised MPLS) has been defined by the IETF as a protocol for switched optical networks. It provides

the necessary bridges between the IP and photonic layers in a scalable way. By combining the flexible intelligence of MPLS TE, the business value of GMPLS will prove essential in any solution that aims at enabling large volumes of traffic in a cost-efficient manner for service providers. 6

Carine Genoud-Voigt holds an engineering degree in electrical engineering from the Swiss Federal Institute of Technology in Lausanne (EPFL). She worked for 3½ years for Ascom in an ATM development department and then in the PBX and Call Center domain. In October 1997, she joined Swisscom Corporate Technology where she is working in the domain of broadband technology (ATM, IP, MPLS TE, QoS).

Leila Lamti-BenYacoub received her engineering diploma in computer science in an engineering school in Tunisia in 1995 and completed Ph.D. studies in ENST Bretagne-France from 1995 to 1999 where she worked as a research assistant. Her Ph.D. work was dealing with traffic management and QoS engineering in IP and ATM networks. She joined Swisscom Corporate Technology in 1999. She is working in the area of service provisioning with QoS and performance management in IP networks, with a specific focus on MPLS Traffic Engineering solutions.

Andreas Schmid received his diploma in electrical engineering from the ETH Zürich in 1998 performing his master thesis at IBM research in Rüschlikon. He joined the Swisscom Corporate Technology Outpost in Zürich (OSI-LAB) immediately afterwards. His interest lies in various aspects of IP and MPLS networks like IP services (especially VPN), protocols, QoS, the mobile Internet, etc. and in the management of such new world networks.

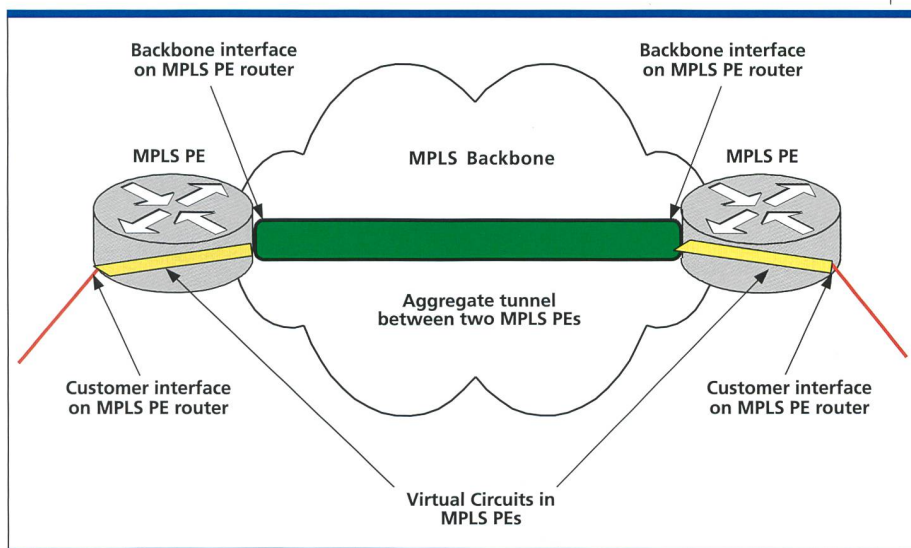

Fig. 4. Description of the backbone part of the VLL service.

Abbreviations

CBR	Constraint-Based Routing
CoS	Class of Service
DiffServ	Differentiated Services
DSCP	DiffServ Code-Point
FR	Frame Relay
IGP	Interior Gateway Protocol
LSP	Label Switched Path
LSR	Label Switched Router
MPLS	Multi-Protocol Label Switching
MTR	Mean Time To Repair
PE	Provider Edge
RSVP	ReSource reservation Protocol
QoS	Quality of Service
SLA	Service Level Agreement
SME	Small and Medium Enterprise
TE	Traffic Engineering
VC	Virtual Channel
VLAN	Virtual LAN
VLL	Virtual Leased Line

References

- [1] D. Awduche et al.: "Requirements for Traffic Engineering over MPLS", RFC 2702, September 1999.
- [2] D. Katz and D. Yeung: "Traffic Engineering Extensions to OSPF", draft-katz-yeung-ospf-traffic, work in progress, June 2001.
- [3] H. Smit and T. Li: "IS-IS Extensions for Traffic Engineering", draft-ietf-isis-traffic, work in progress, August 2001.
- [4] A. Schmid, L. Lamti: "MPLS Traffic Engineering, Test Report of Lab Tests with Cisco Routers", September 2001, <http://ctep.swissptt.ch/ep34>.
- [5] Gartner Group: "Fixed Public Network Services: Switzerland, 1996–2005, Market Statistics", March 30, 2001.
- [6] ITU-T, SG12, D.110 Nortel Networks: "Subjective results on Impairment Effect of IP Packet Loss", September 1999.
- [7] Eurescom P906: "QUASIMODO – QUALity of Service METHODOlogies and Solutions within the Service Framework: Measuring, Managing and Charging QoS", March 1999.
- [8] P. Demeester: "IMEC-Ghent", ECOC 2000.

Zusammenfassung

MPLS Traffic Engineering (TE) ist ein neuer Trend für die Optimierung von Netzen und für die Überwachung von Diensten. MPLS TE ermöglicht eine Dienstendifferenzierung, die es erlaubt, verschiedene Applikationen mit unterschiedlichen Qualitätsanforderungen auf einer gemeinsamen IP-Plattform zu transportieren. Wir haben die MPLS-TE-Eigenschaften in einem frühen Umsetzungsstadium in einem experimentellen Testumfeld evaluiert und schlagen vor, MPLS-TE-Mechanismen für die Implementierung eines virtuellen Mietleistungsdienstes (VLL) zu benutzen. Dieser Dienst wird als eine kostengünstige Alternative zu klassischen Mietleitungen betrachtet, der eine echte Konvergenz auf einem Netz ermöglicht.

Genesis fängt Sonnenteilchen ein

Die von der NASA gestartete Genesis-Mission ist in ihre aktive Phase eingetreten. Die Raumsonde hat Anfang Dezember 2001 damit begonnen, Atome des «Sonnenwinds» einzufangen. Die Wissenschaftler gehen davon aus, dass der Sonnenwind Teil eines frühen Sonnennebels ist, aus dem unser Sonnensystem vor Jahrmillionen entstanden ist. Man erhofft sich nach Rückkehr der Raumsonde im Jahr 2004 neue Informationen, wie die Erde und die anderen Planeten entstanden sind. Genesis ist die erste Raumsonde überhaupt, die dann mit Spurenmaterial aus dem Weltraum zurückkommt, das aus einer grösseren Entfernung als der Mond stammt. Der Standort der Sonde liegt rund 1,5 Mio. km von der Erde in Richtung Sonne. Er liegt genau da, wo sich die Anziehungskräfte der Erde und der Sonne im Gleichgewicht halten.

Amerika entdeckt das Potenzial von SMS

Der Short Message Service (SMS) hat längst Kultcharakter in Europa. Die intensive Nutzung des Textservice über Mobilfunkgeräte hat es zu mehr als 750 Mio. SMS pro Tag (!) weltweit gebracht. Weitgehend ausgeschlossen waren bisher davon die USA und Kanada, weil dort SMS wegen der unterschiedlichen Mobilfunksysteme nur zwischen Geräten des gleichen Betreibers möglich sind. Die Kanadier wollten sich damit nicht länger zufrieden geben. Alle grossen kanadischen Mobilfunkbetreiber haben sich jetzt auf ein gemeinsames Übertragungsprotokoll geeinigt. Sollte jetzt die SMS-Euphorie in Kanada ausbrechen, dann erwartet man eine rasche Änderung des gegenwärtigen unbefriedigenden Zustands auch in den USA.

Frequenzen für Mobilfunk in den USA neu geordnet

Die Federal Communications Commission (FCC) rückt von ihrer bisherigen Praxis ab, in den USA pro Betreiber nur eine bestimmte Zahl von Mobilfunkfrequenzen zuzuteilen. Damit wollte man bisher den Wettbewerb fördern. Sie hat sich aber für die schnelle Ausweitung des Mobilfunknetzes als Hemmnis erwiesen. Jetzt geht man davon aus, dass die «Grossen» einige der «Kleinen» schlucken werden, um der wachsenden Teilnehmernachfrage in Ballungszentren zu entsprechen.