

**Zeitschrift:** Cahiers d'archéologie romande  
**Herausgeber:** Bibliothèque Historique Vaudoise  
**Band:** 49 (1990)

**Artikel:** Un quartier romain de Nyon : de l'époque augustéenne au IIIe siècle :  
(les fouilles de Bel-Air/gare 9 - 1978-1982)  
**Autor:** Morel, Jacques / Amstad, Silvio  
**Rubrik:** [Planches]  
**DOI:** <https://doi.org/10.5169/seals-835418>

### **Nutzungsbedingungen**

Die ETH-Bibliothek ist die Anbieterin der digitalisierten Zeitschriften auf E-Periodica. Sie besitzt keine Urheberrechte an den Zeitschriften und ist nicht verantwortlich für deren Inhalte. Die Rechte liegen in der Regel bei den Herausgebern beziehungsweise den externen Rechteinhabern. Das Veröffentlichen von Bildern in Print- und Online-Publikationen sowie auf Social Media-Kanälen oder Webseiten ist nur mit vorheriger Genehmigung der Rechteinhaber erlaubt. [Mehr erfahren](#)

### **Conditions d'utilisation**

L'ETH Library est le fournisseur des revues numérisées. Elle ne détient aucun droit d'auteur sur les revues et n'est pas responsable de leur contenu. En règle générale, les droits sont détenus par les éditeurs ou les détenteurs de droits externes. La reproduction d'images dans des publications imprimées ou en ligne ainsi que sur des canaux de médias sociaux ou des sites web n'est autorisée qu'avec l'accord préalable des détenteurs des droits. [En savoir plus](#)

### **Terms of use**

The ETH Library is the provider of the digitised journals. It does not own any copyrights to the journals and is not responsible for their content. The rights usually lie with the publishers or the external rights holders. Publishing images in print and online publications, as well as on social media channels or websites, is only permitted with the prior consent of the rights holders. [Find out more](#)

**Download PDF:** 14.04.2026

**ETH-Bibliothek Zürich, E-Periodica, <https://www.e-periodica.ch>**

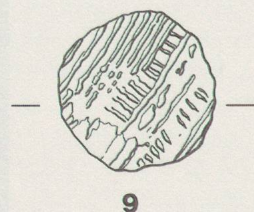
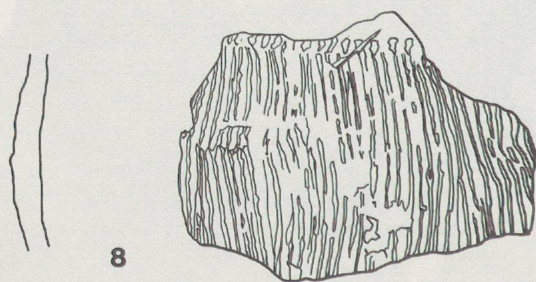
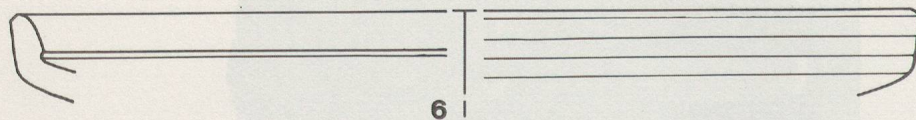
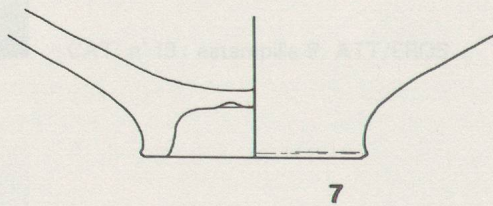
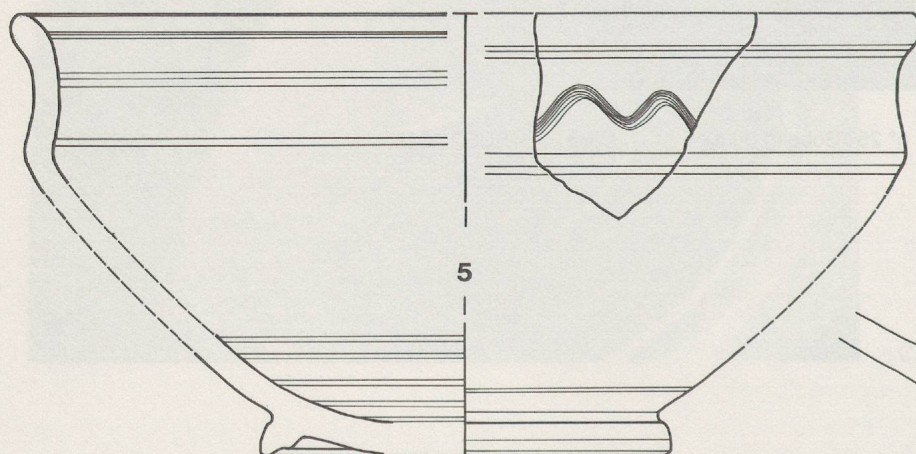
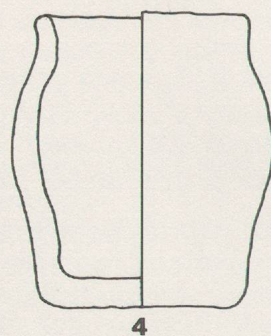
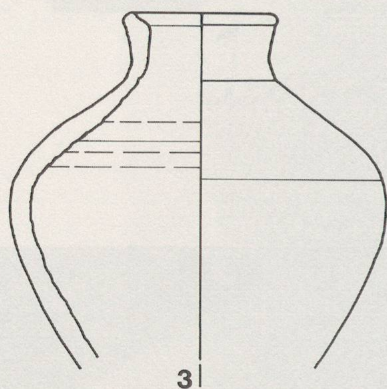
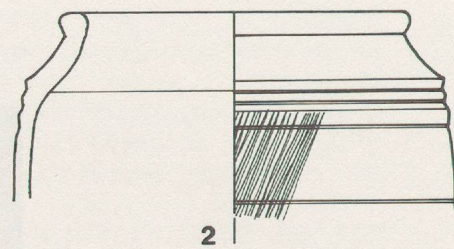
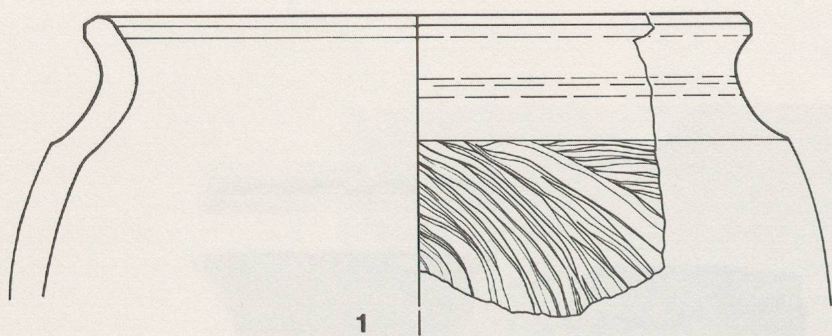

1 - 10 : Céramique à pâte sombre. Ech. 1 : 2.

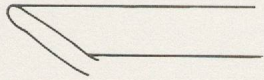

11

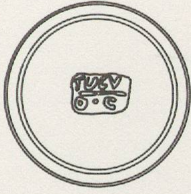

12

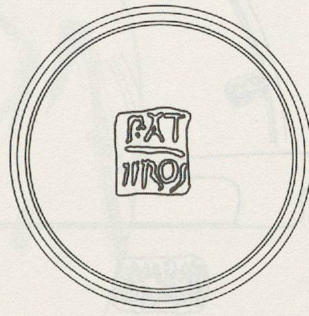

13

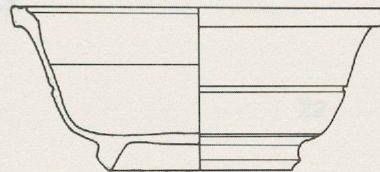
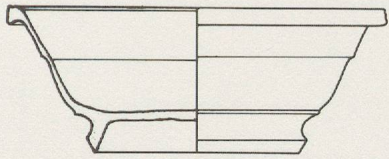

14

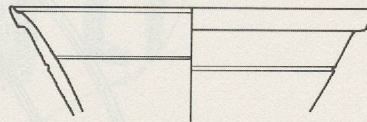

15

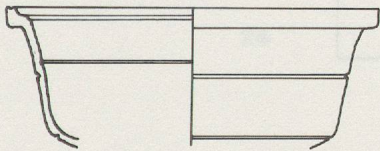

16

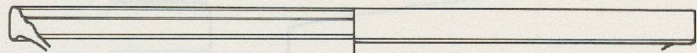

17

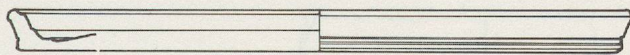

18



19

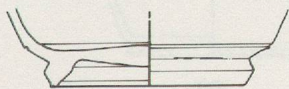

20



21



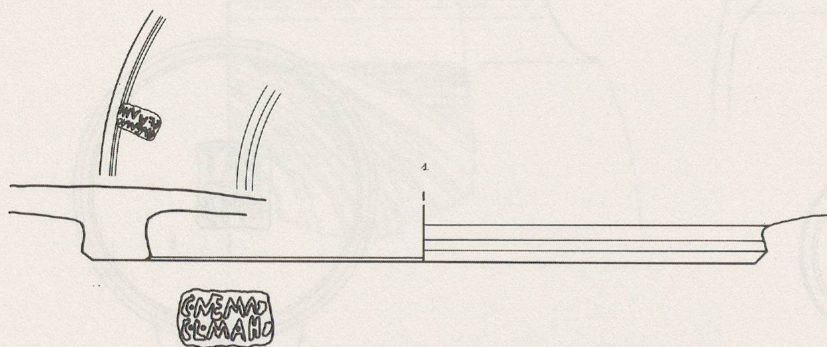

22

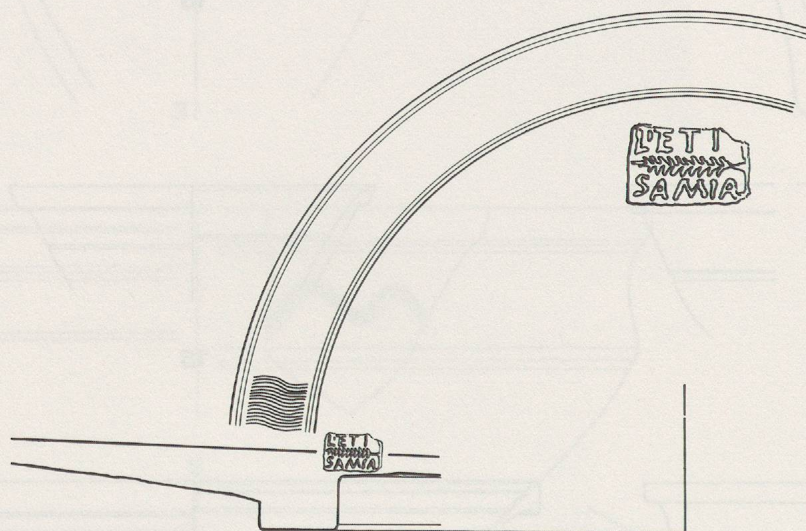

23

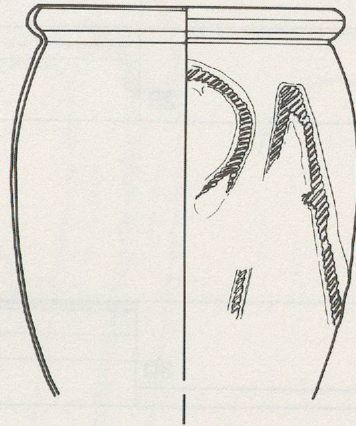

22

23



24

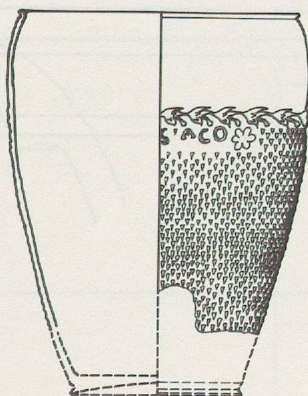

25

ILARYS'ACO

26

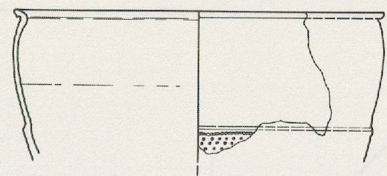

27

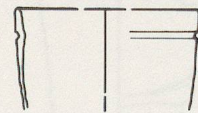

28

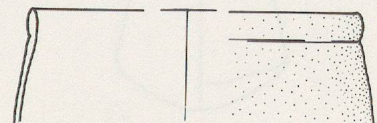

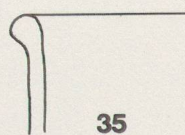
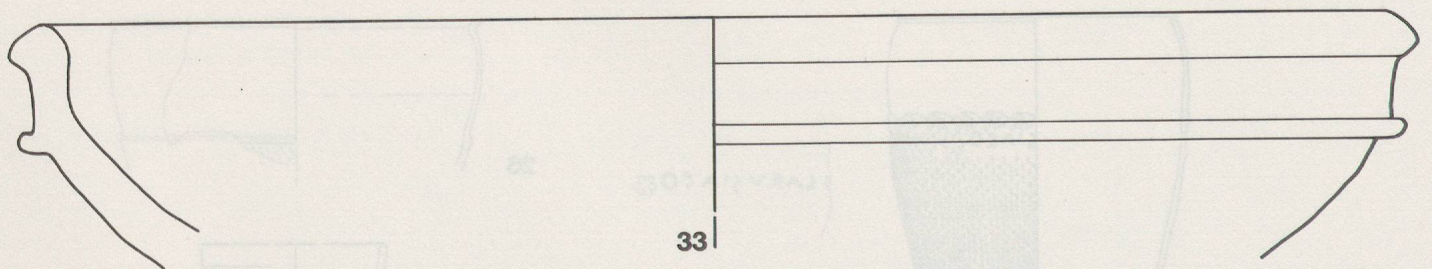
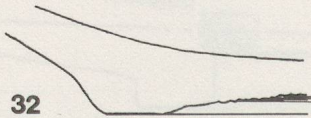
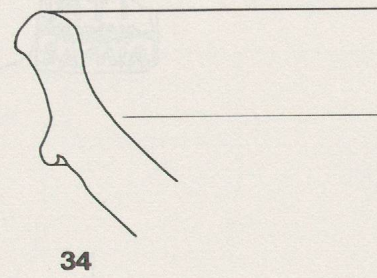
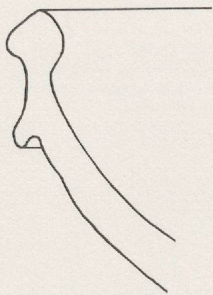
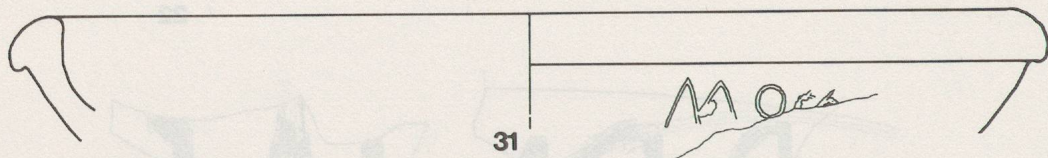
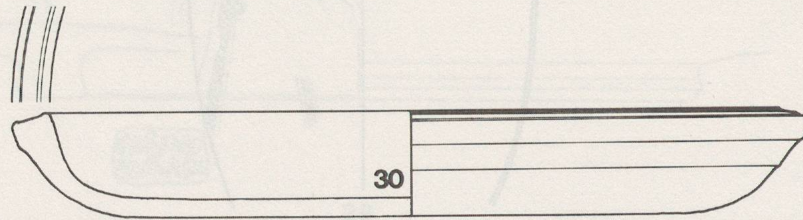
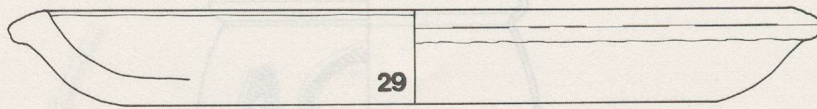

29 - 31 : Plats à engobe interne rouge. 32 - 34 : Mortiers. 35 : Cruche ? Ech. 1 : 2.

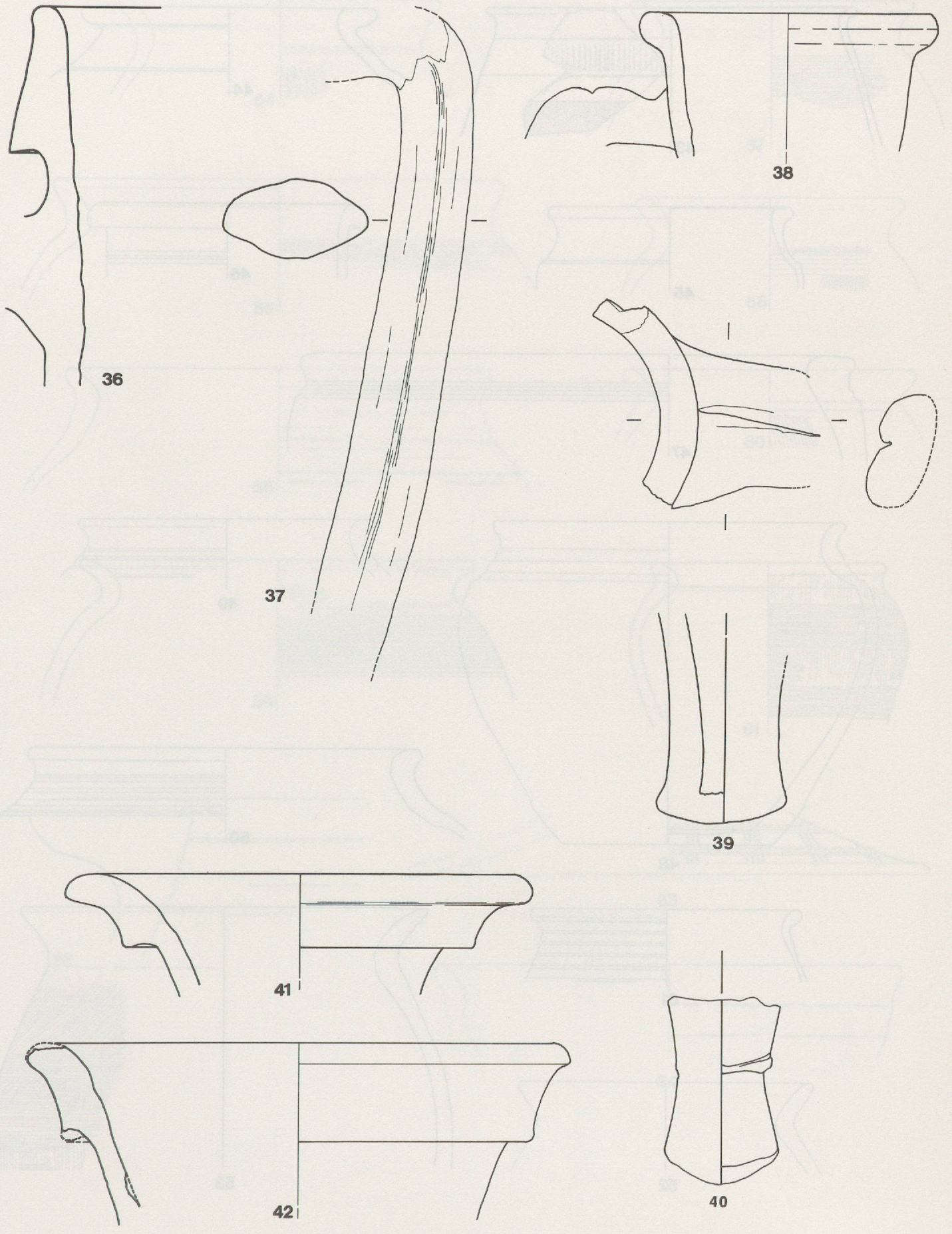

36 : 42 : Amphores. Ech. 1 : 2

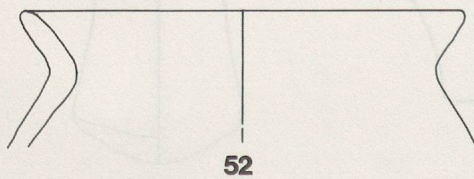
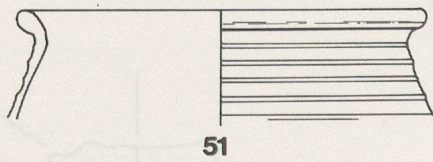
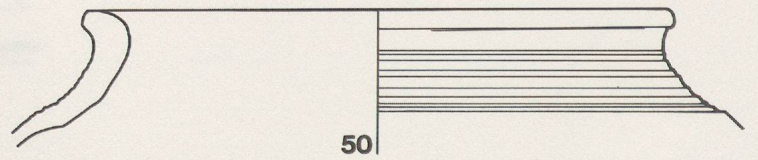
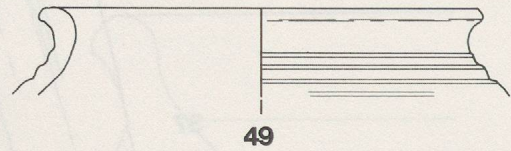
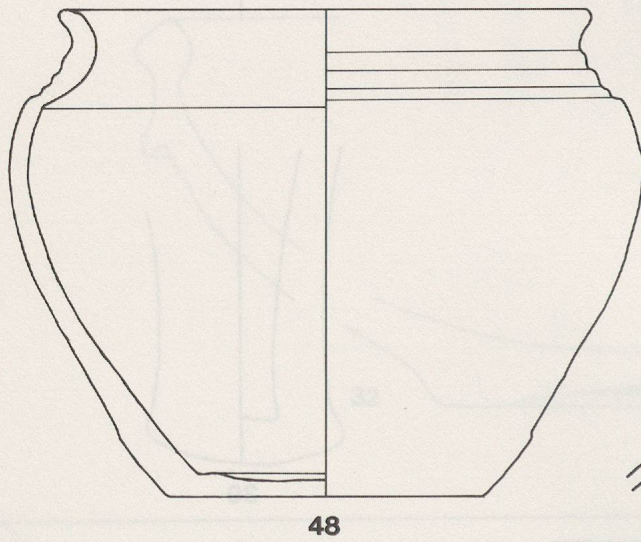
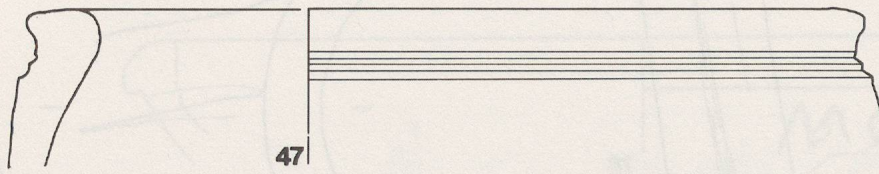
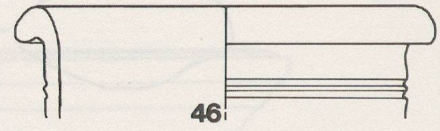
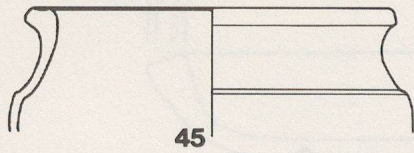
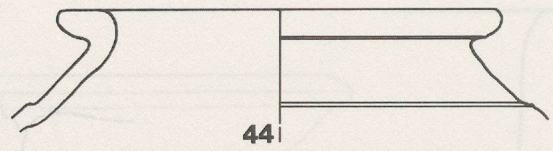
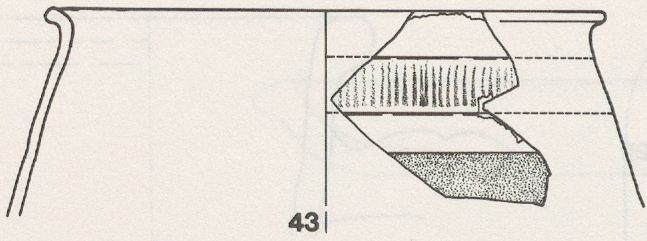

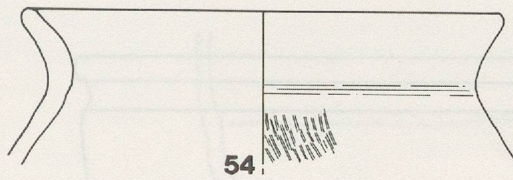

54

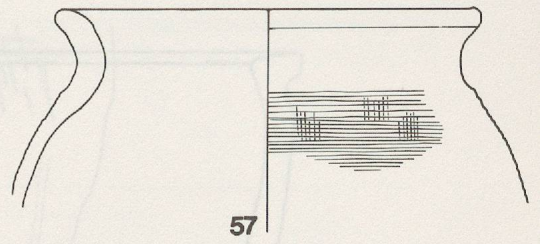

57

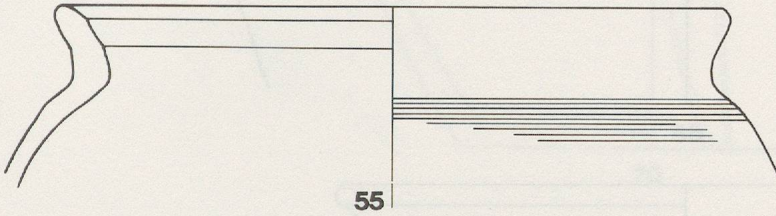

55

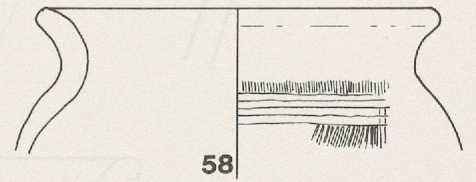

58

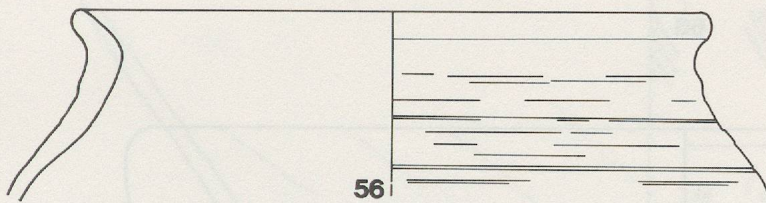

56

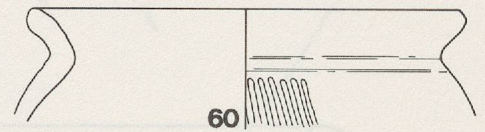

60

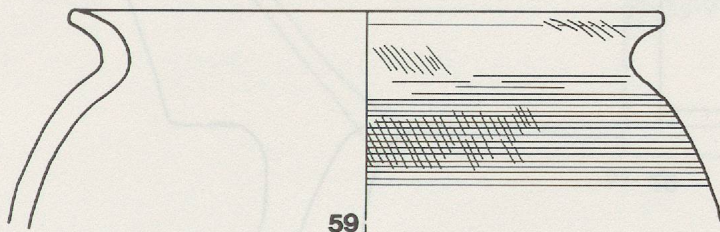

59

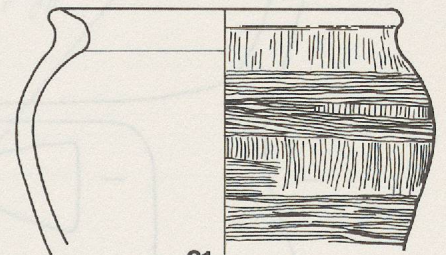

61

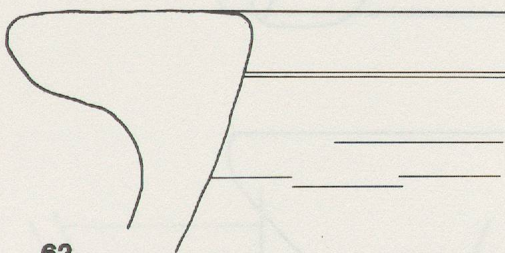

62

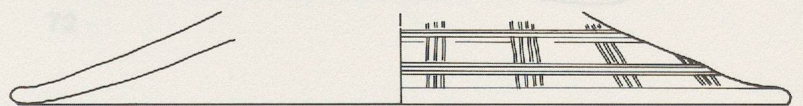

63

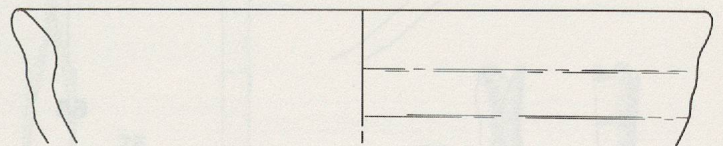

64

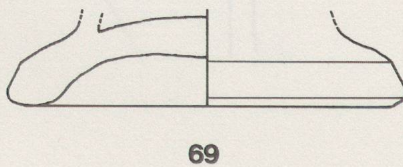
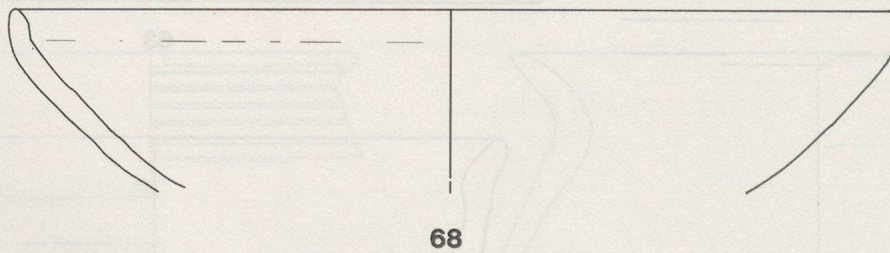
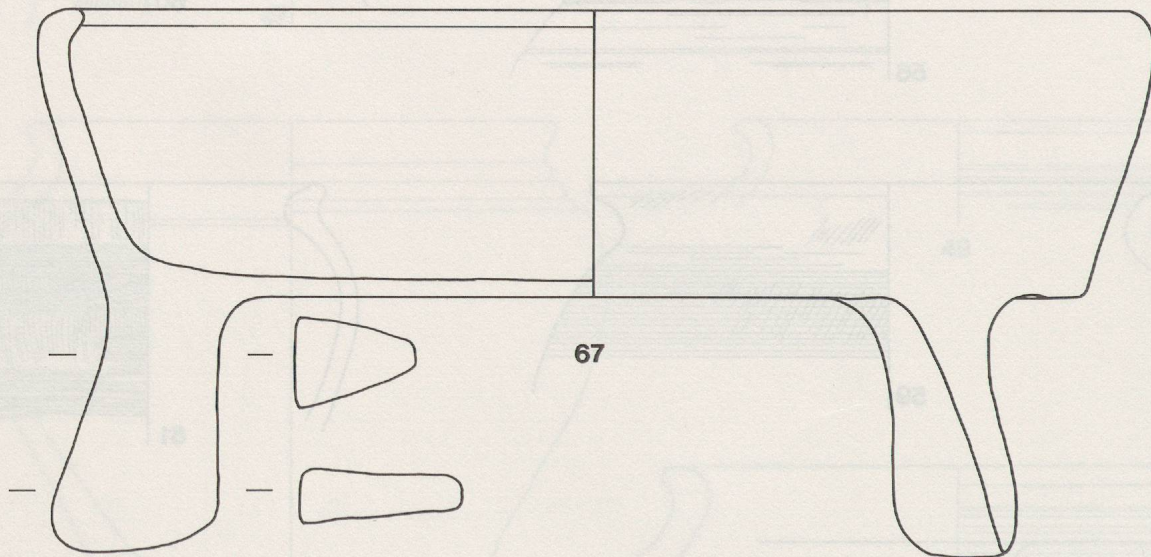
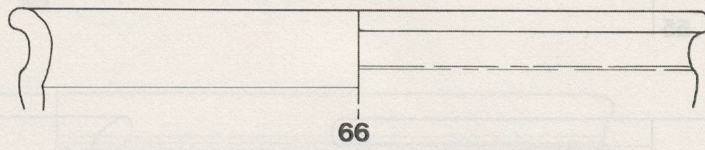
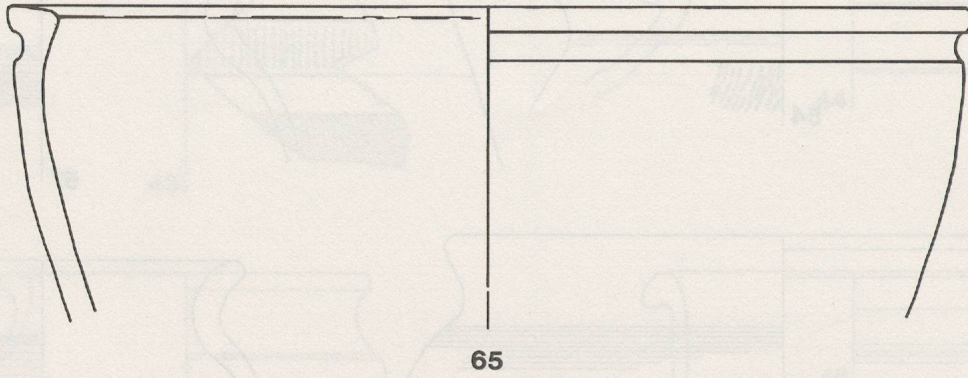

65 - 69 : Céramique à pâte sombre. Ech. 1 : 2.

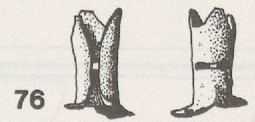
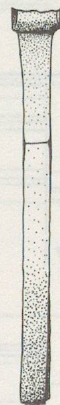
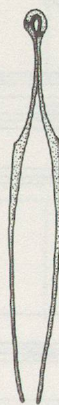
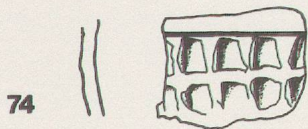
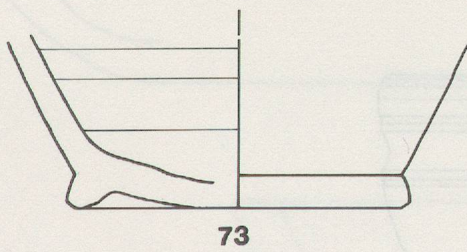
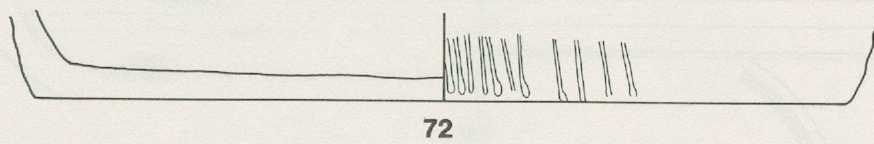
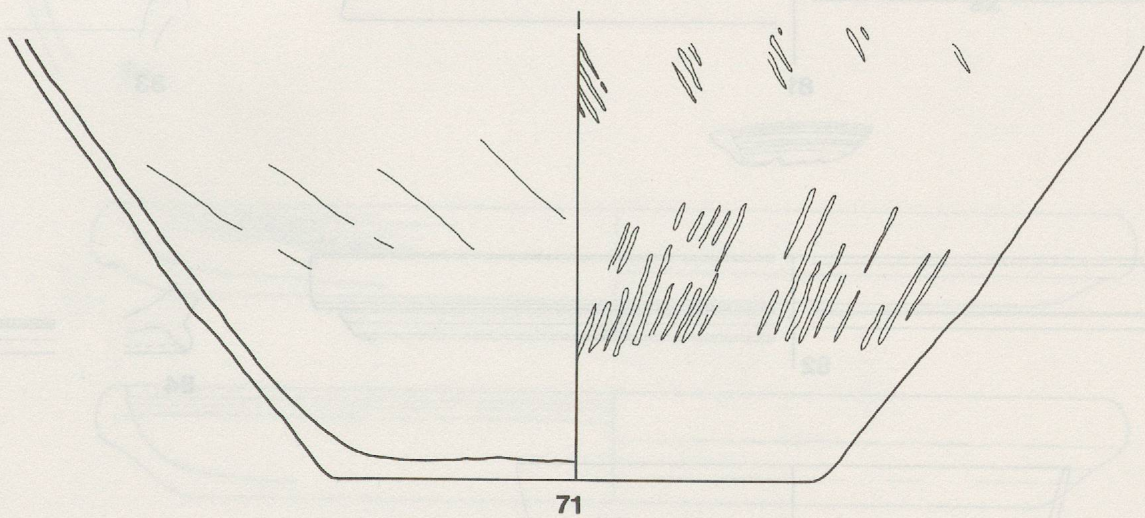
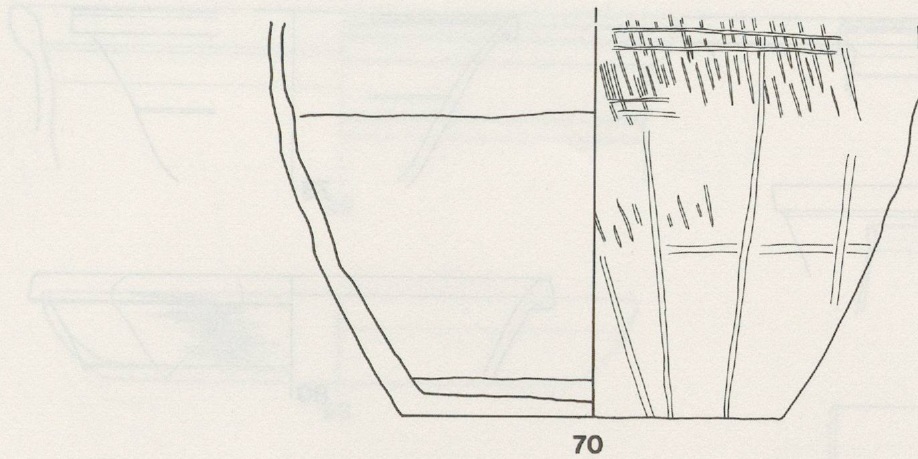

70 : 74 : Céramique à pâte sombre. 75 - 76 : Bronze. Ech. 1 : 2.

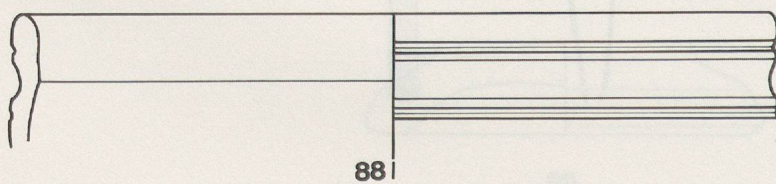
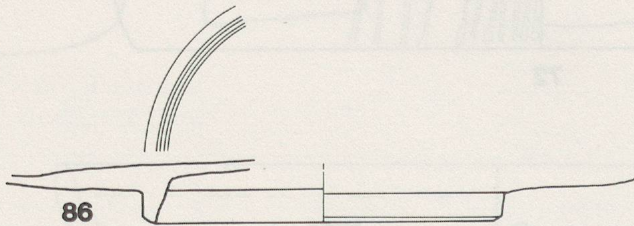
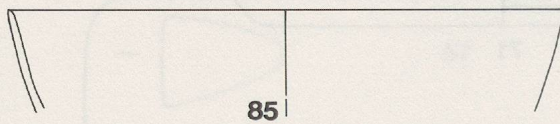
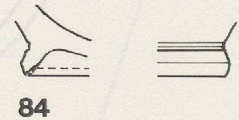
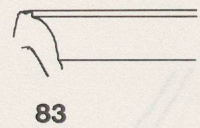
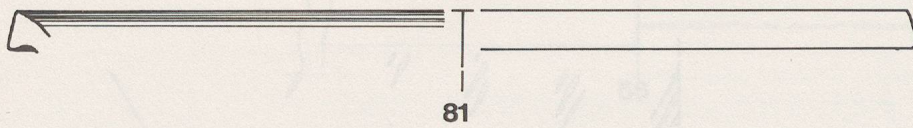
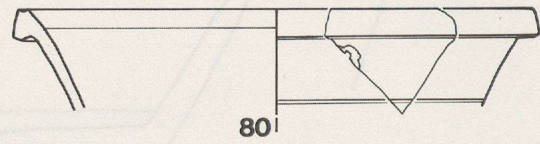
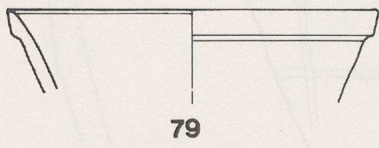
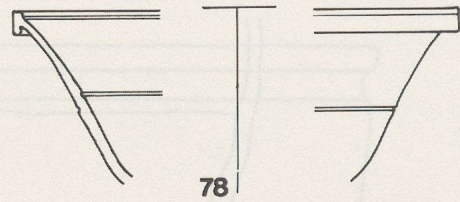
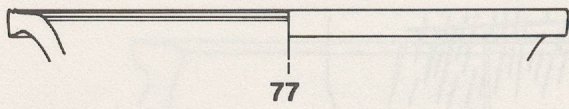

77 - 86 : TS italique. 87 - 88 : Imitations TS. Ech. 1 : 2.

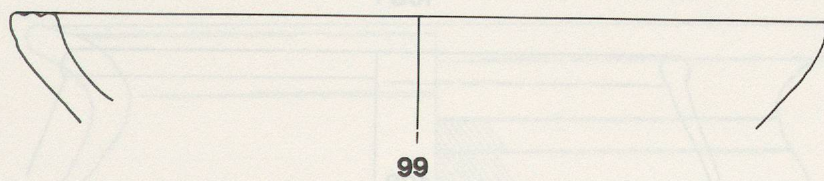
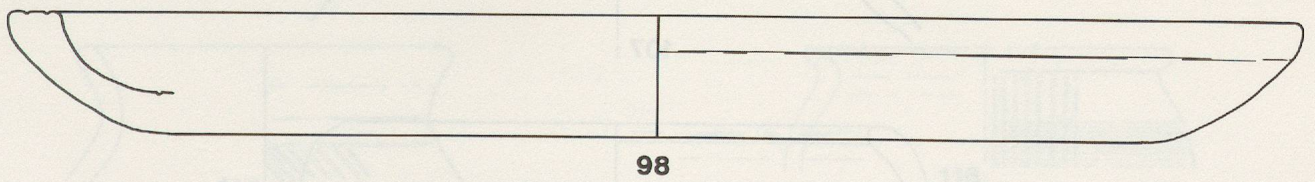
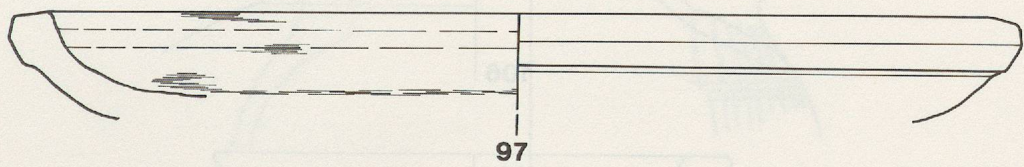
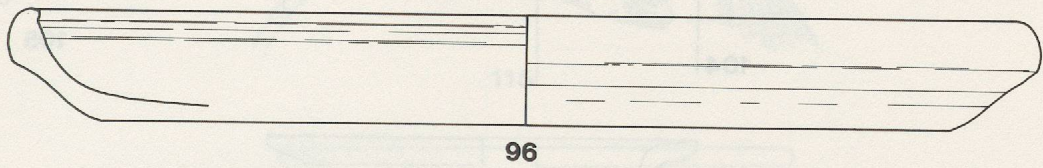
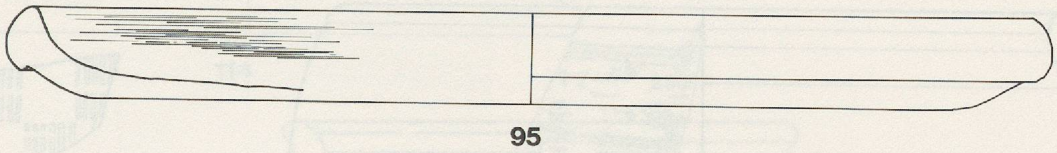
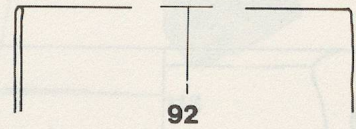
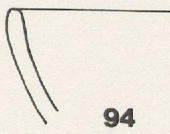
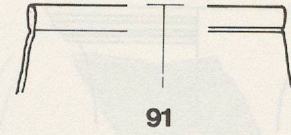
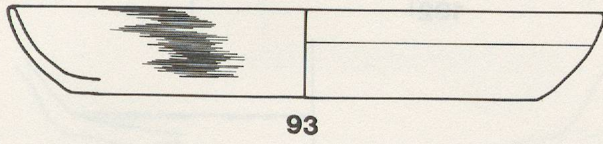
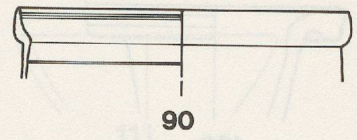
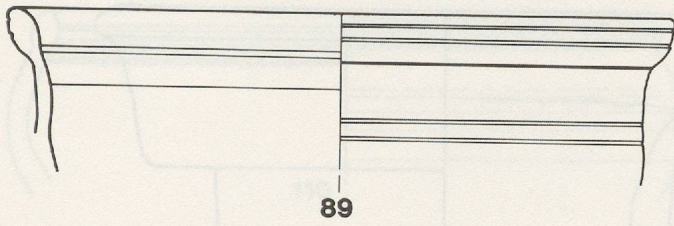

89 : Imitation TS. 90 - 92 : Parois fines. 93 - 99 : Plats à engobe interne rouge. Ech. 1 : 2.

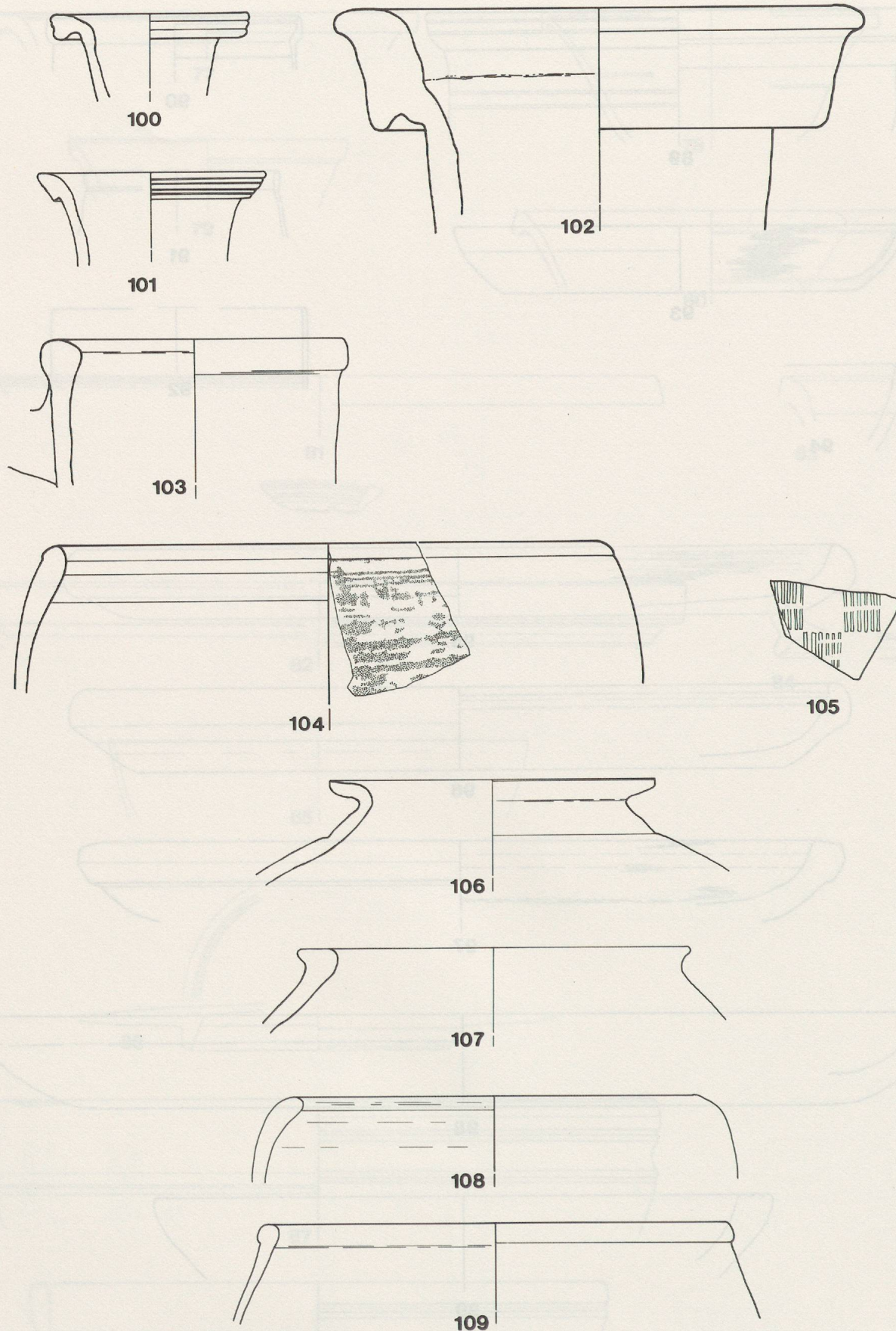

100 - 101 : Cruches. 102 - 103 : Amphores. 104 - 105 : Céramique peinte. 106 - 109 : Pâte claire. Ech. 1 : 2.

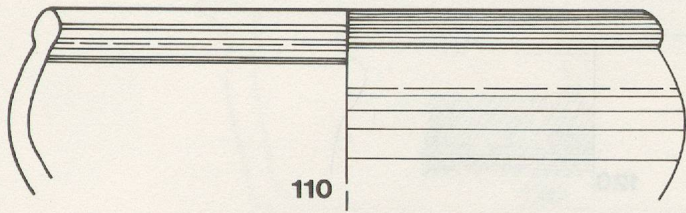

110

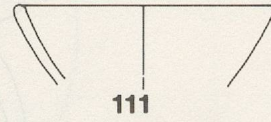

111

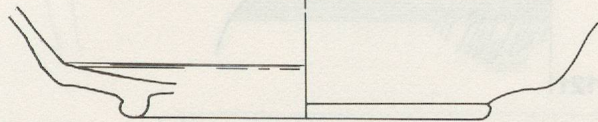

112

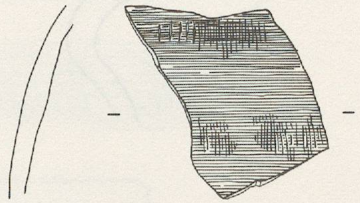

113

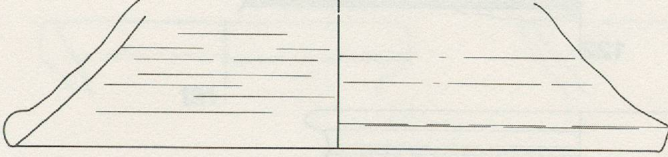

114

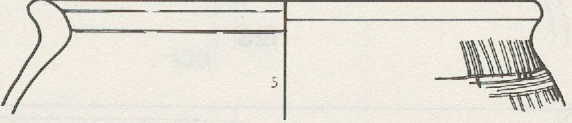

115

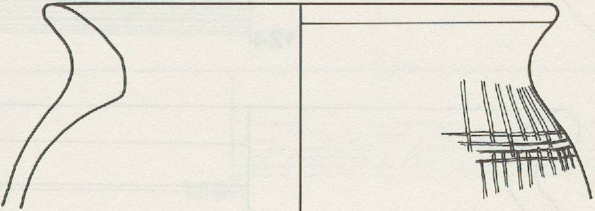

116

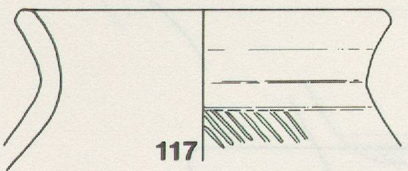

117

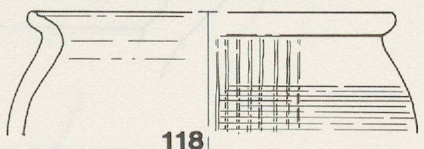

118

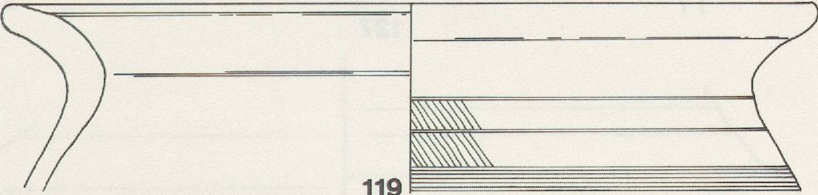

119

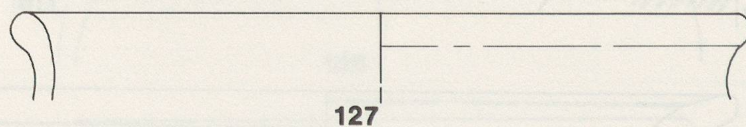
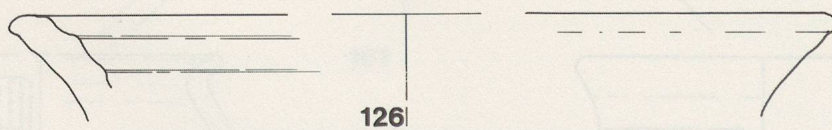
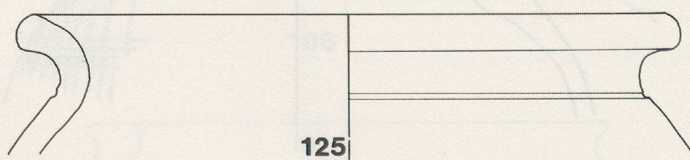
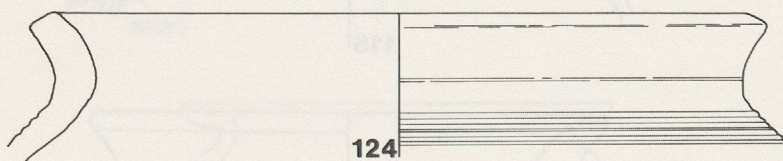
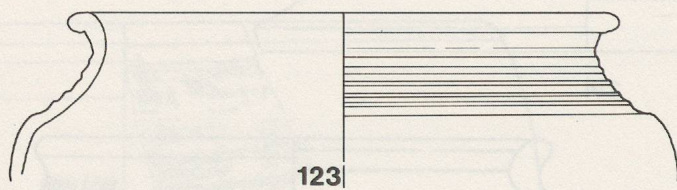
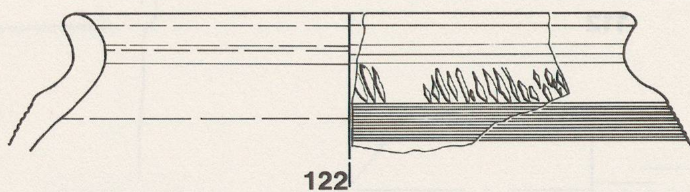
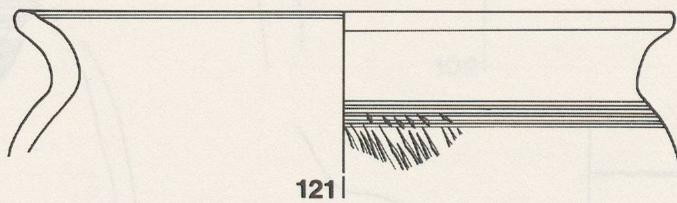
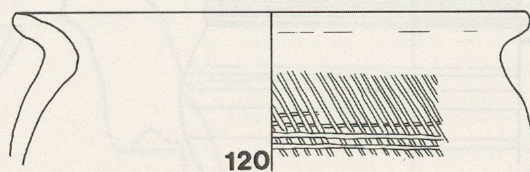

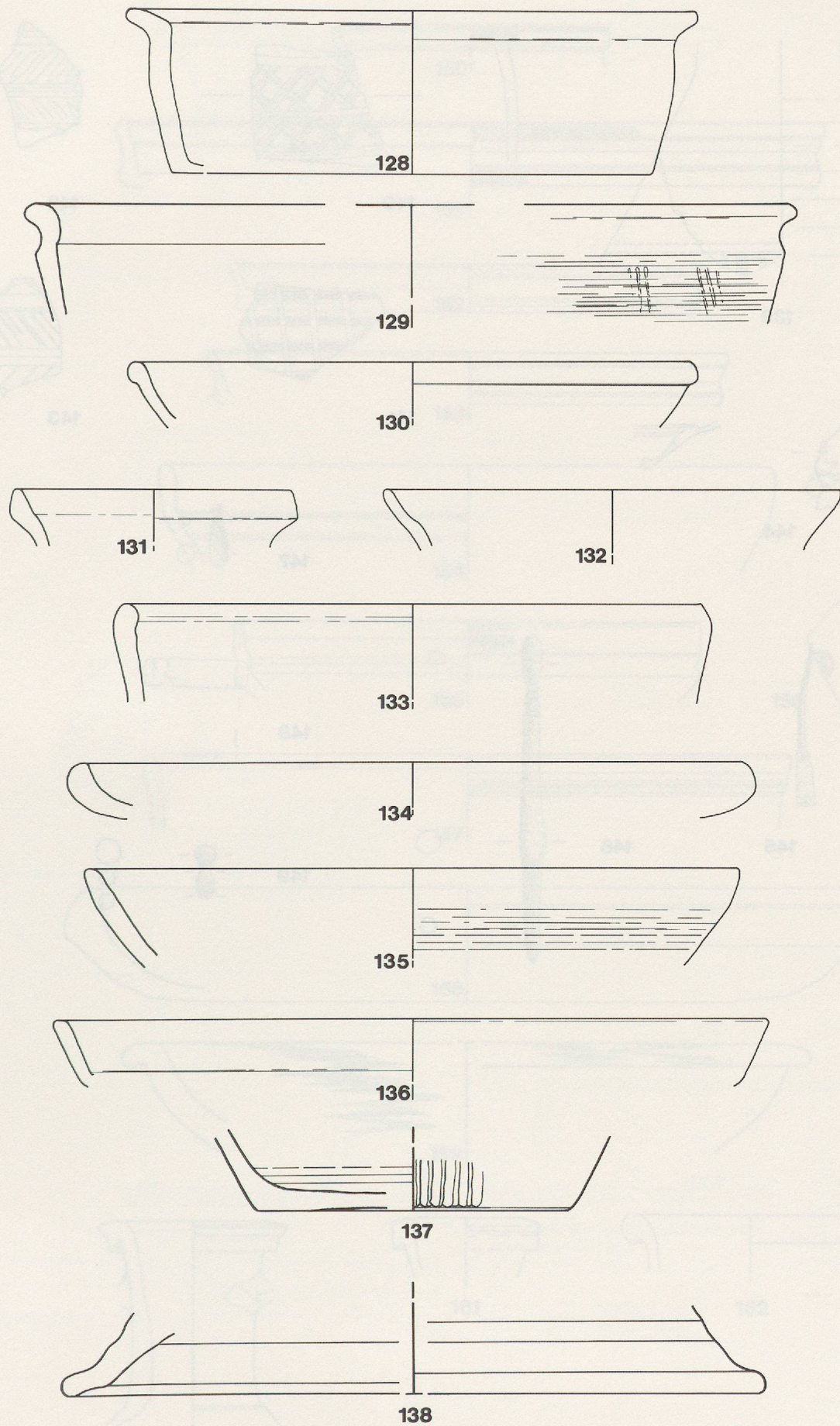

128 - 138 : Céramique à pâte sombre. Ech. 1 : 2.

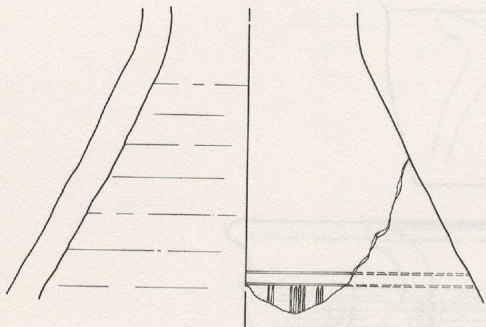

139

140

142

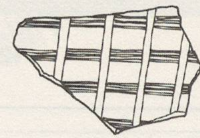

141



143

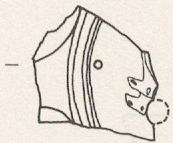

144



147

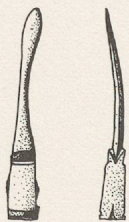

145



146

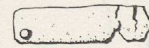

148



149

139 - 143 : Céramique à pâte sombre. 144 : Lampe à huile. 145, 148 et 149 : Bronze. 146 - 147 : Os.

Ech. 1 : 2.

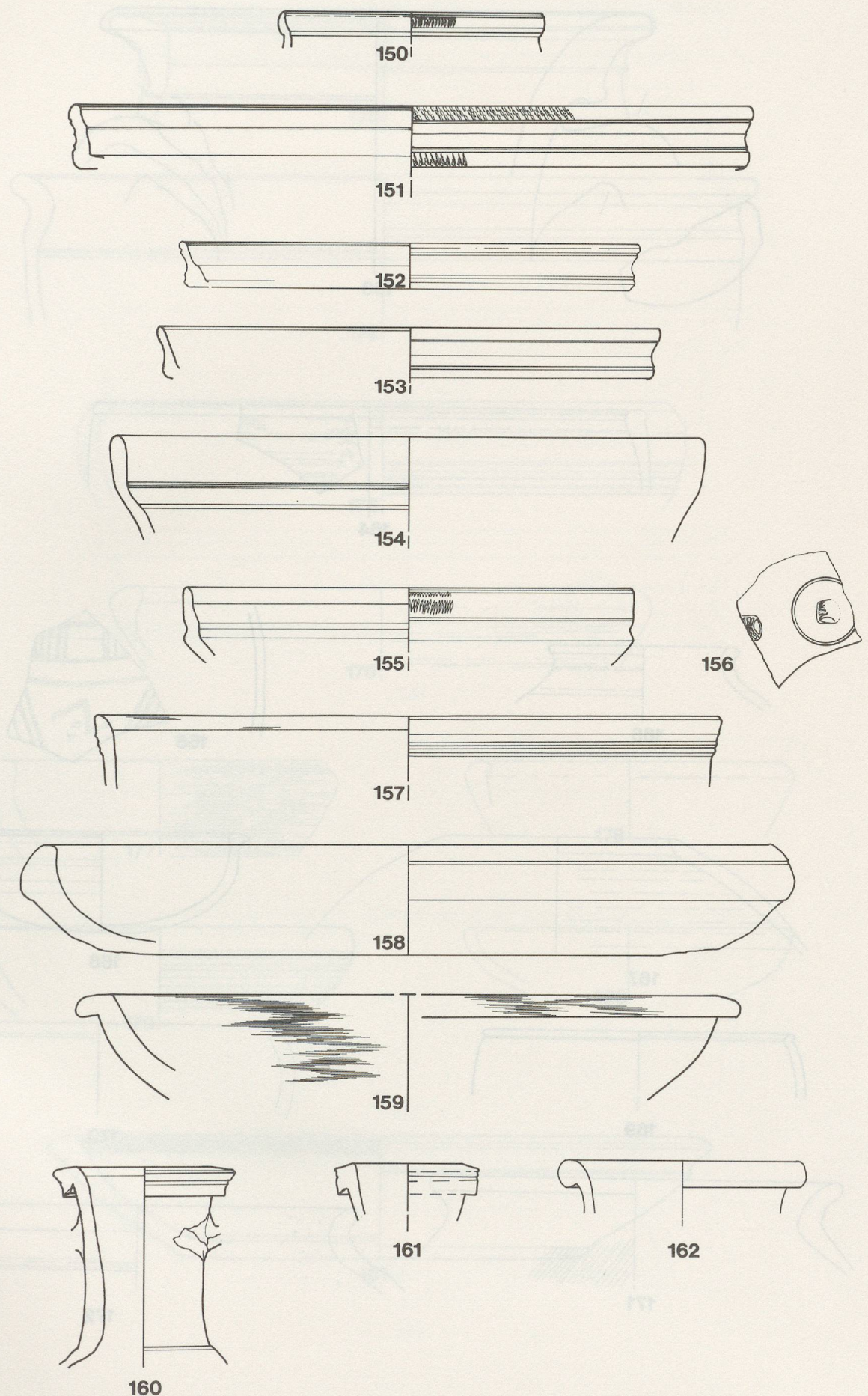

150 : 152 : TS. 153 - 157 : Imitations TS. 158 - 159 : Engobe interne rouge. 160 - 162 : Cruches. Ech. 1 : 2.

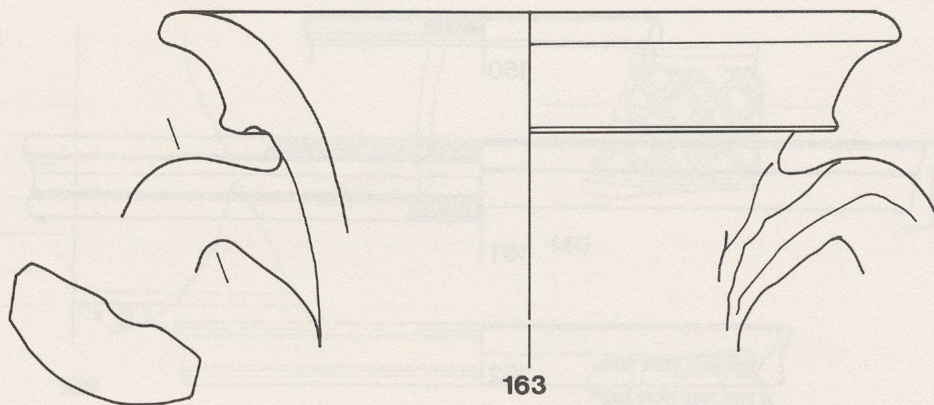

163

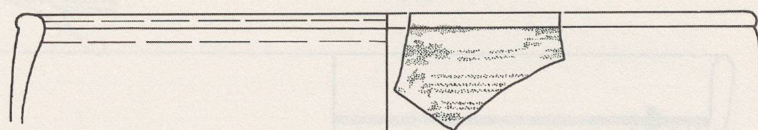

164

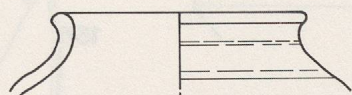

165

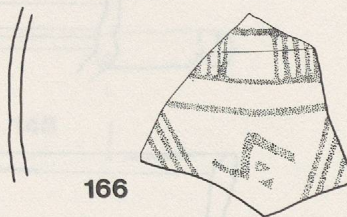

166



167

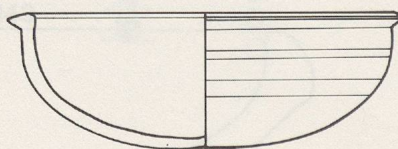

168

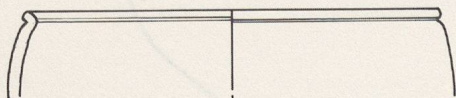

169

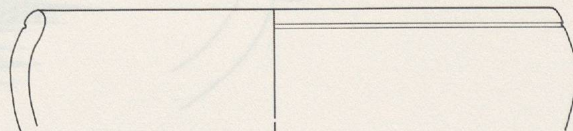

170

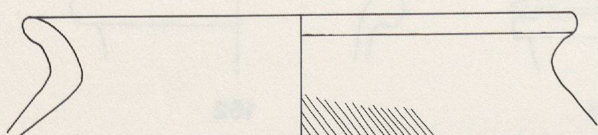

171

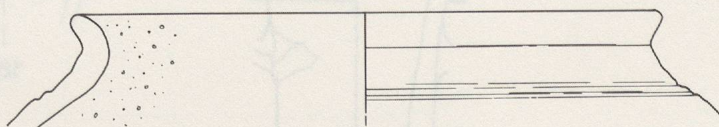

172

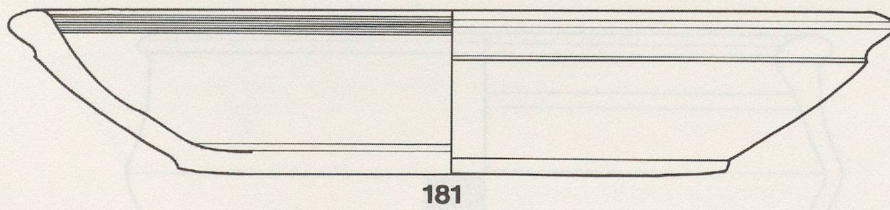
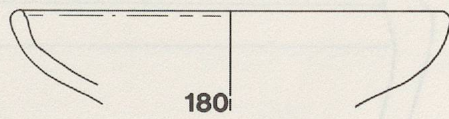
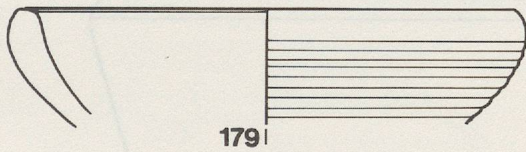
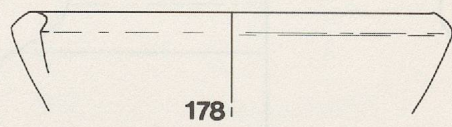
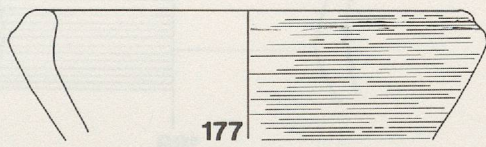
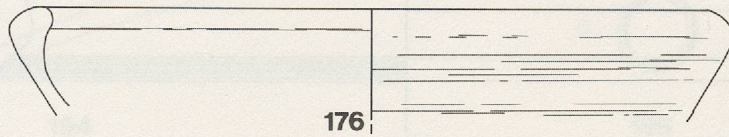
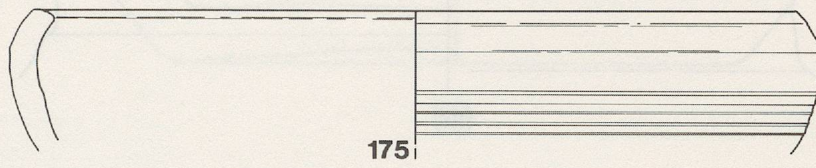
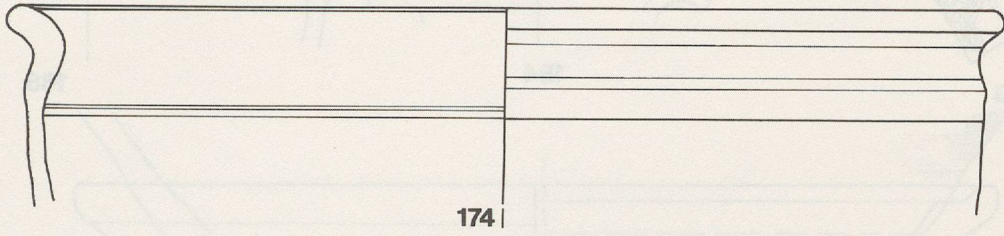
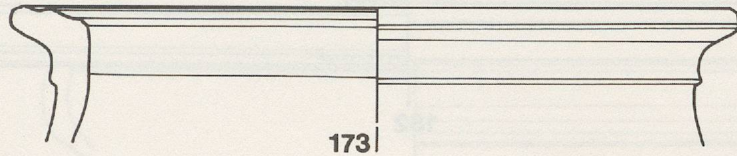

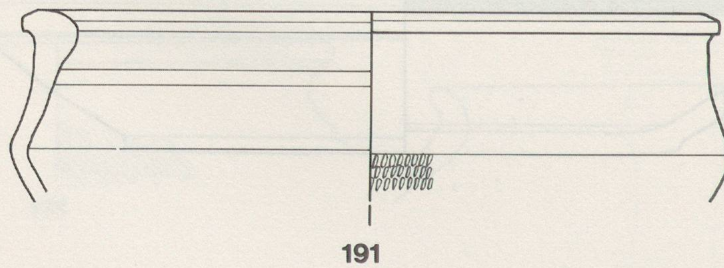
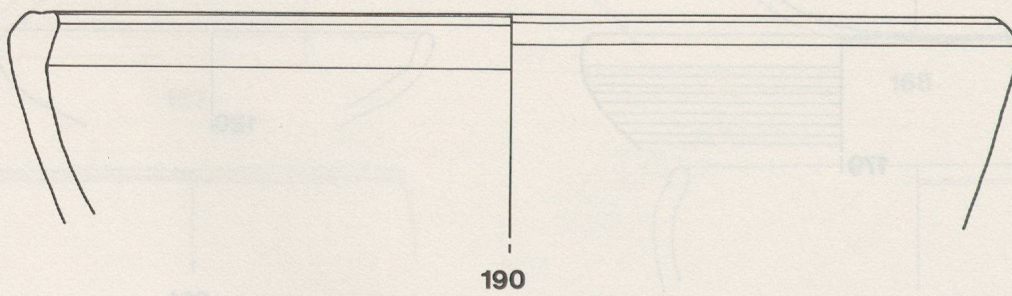
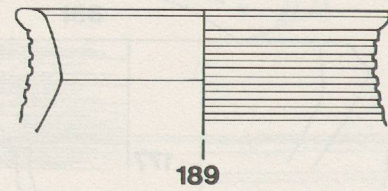
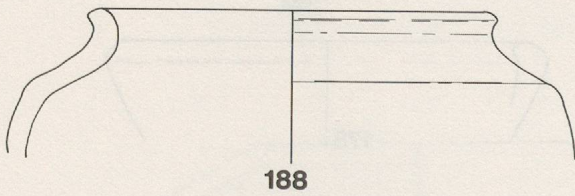
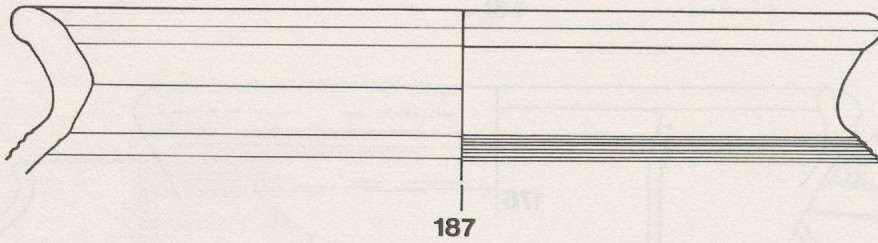
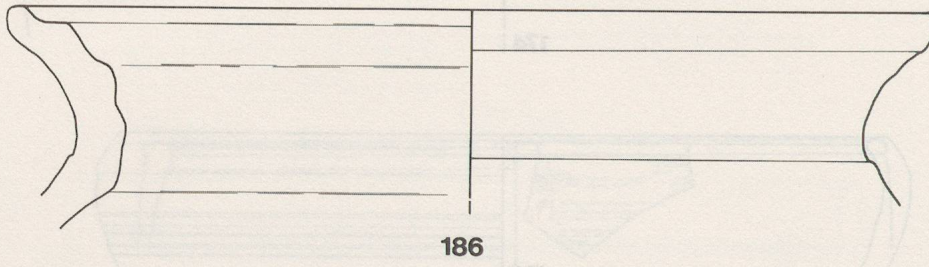
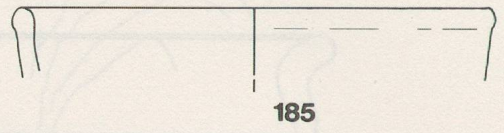
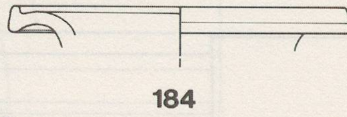
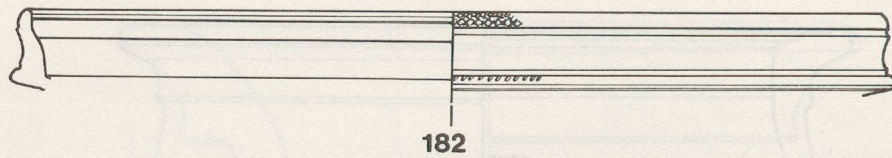

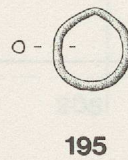
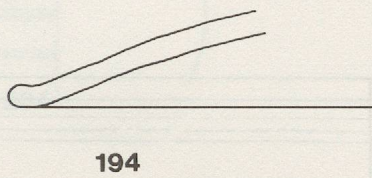
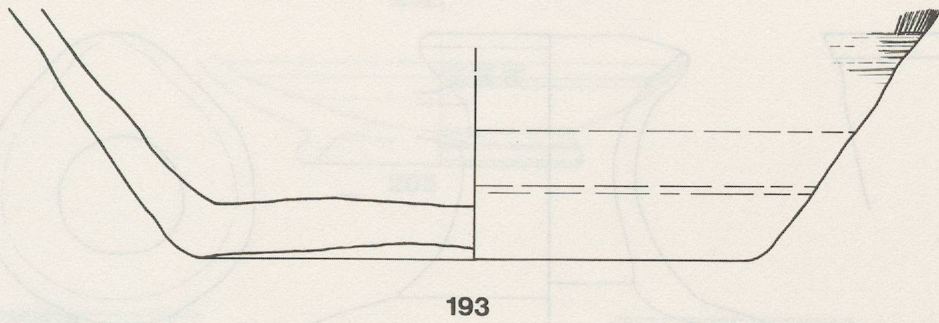
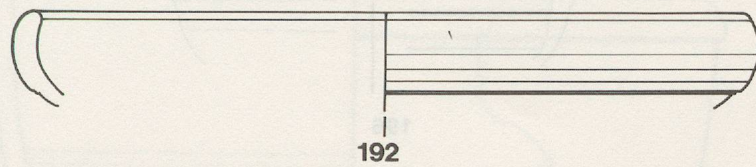

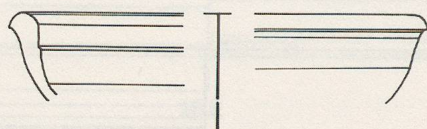

196

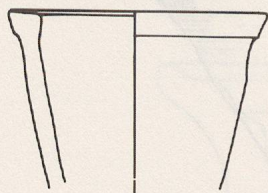

197

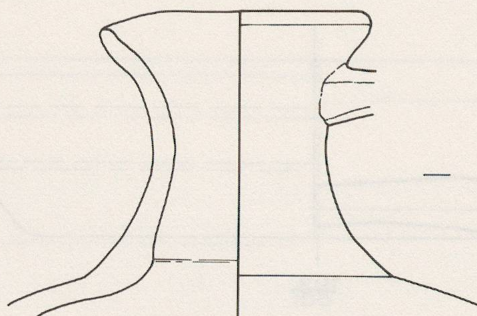

198

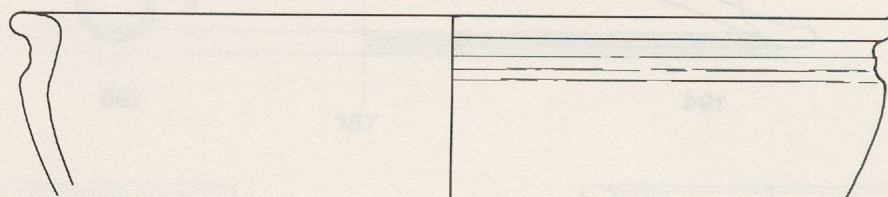
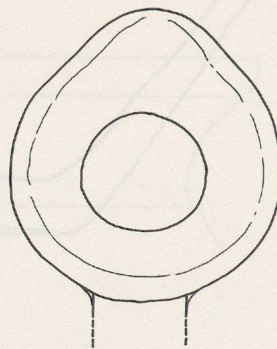

199

Etat 3C

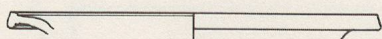

200

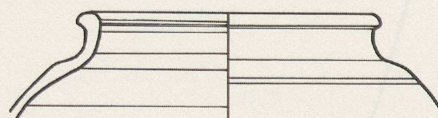

201

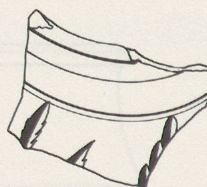

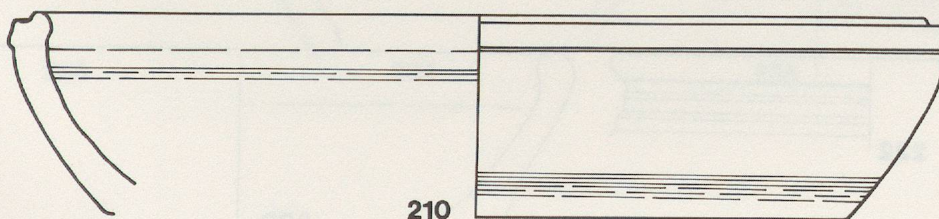
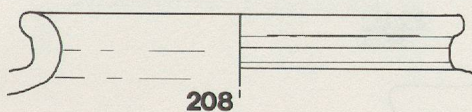
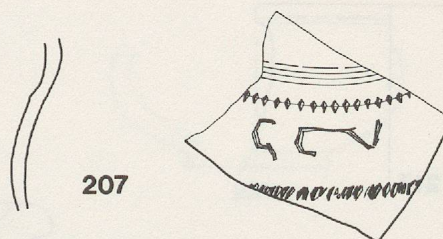
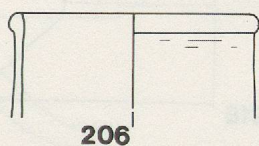
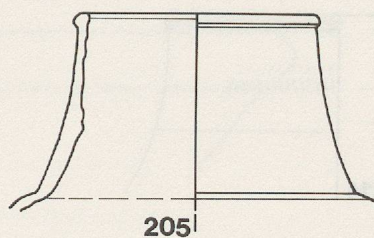
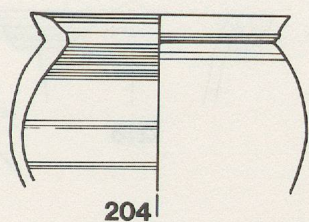
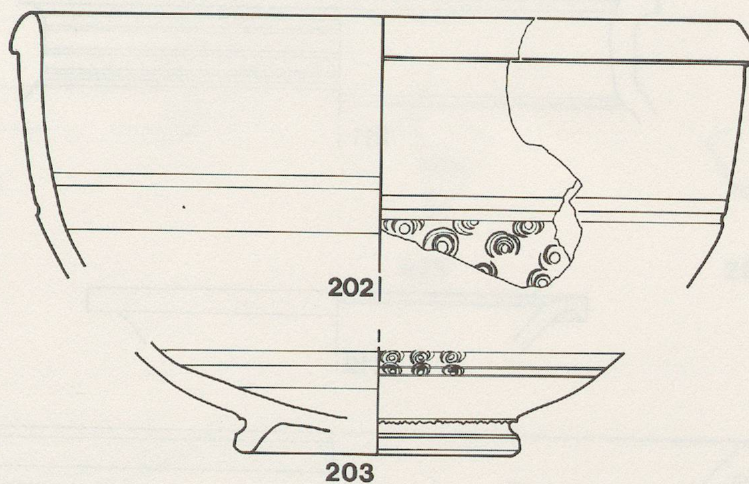

202 - 207 : Revêtement argileux. 208 : Allobroge (?). 209 - 210 : Pâte claire. Ech. 1 : 2.

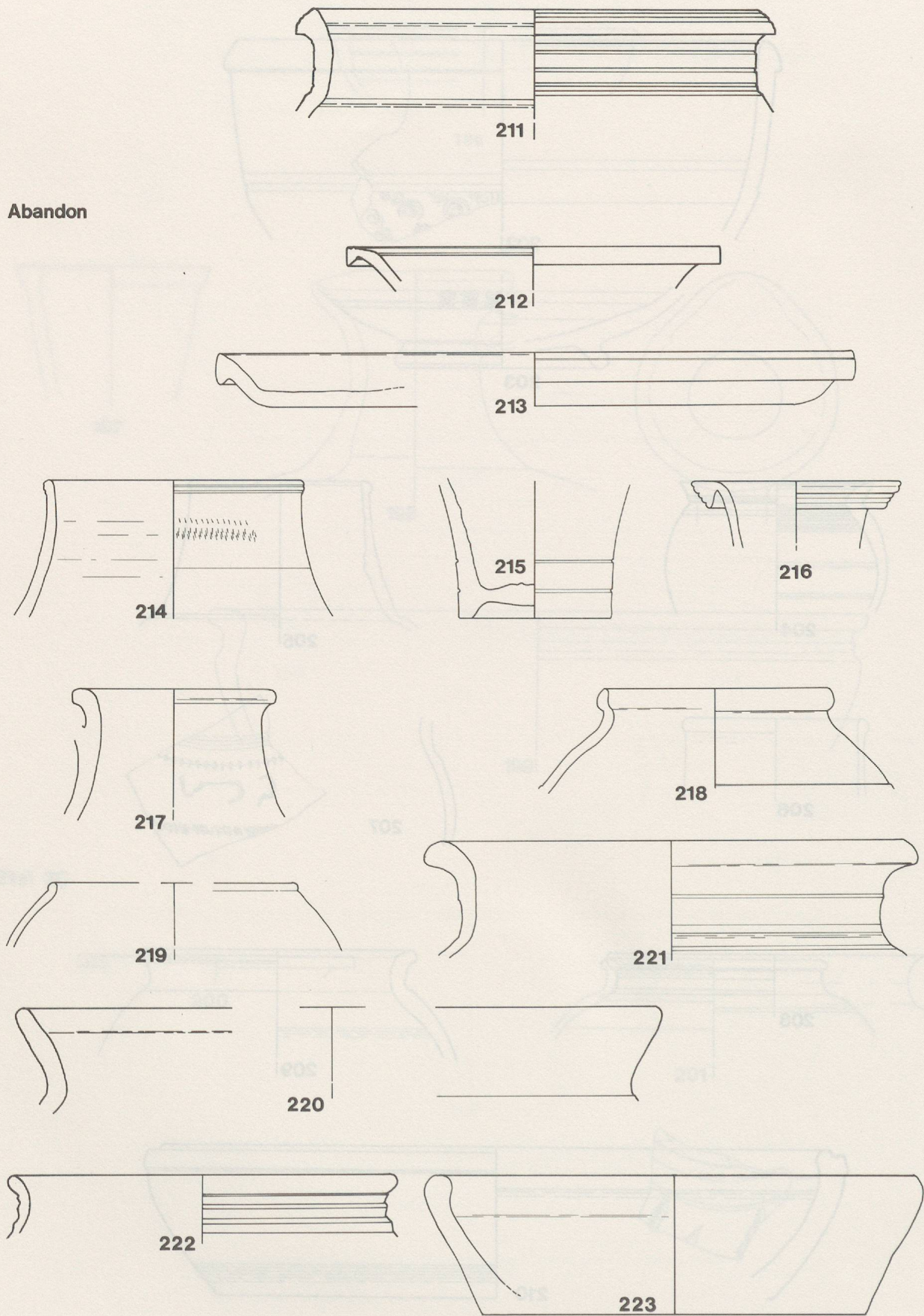

211 : Pâte sombre. 212 : TS italique. 213 : Imitation TS. 214 - 215 : Revêtement argileux. 216 - 217 : Cruches.  
 218 - 219 : Pâte claire. 220 - 223 : Pâte sombre. Ech. 1 : 2.

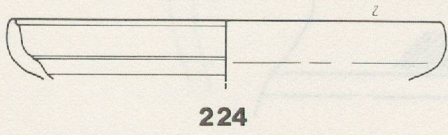

224



225



226

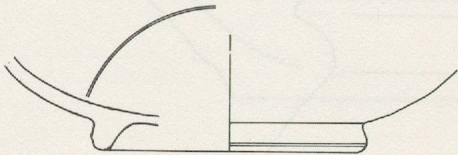

227

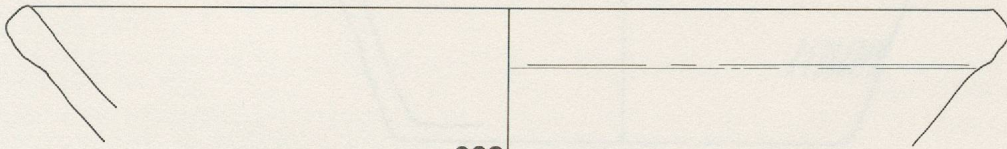

228

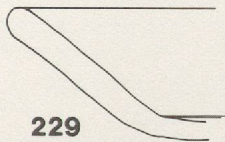

229

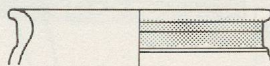

230

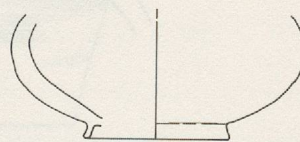

231

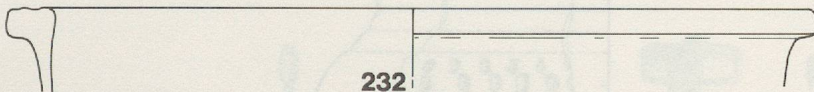

232

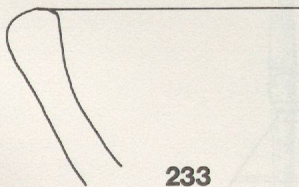

233

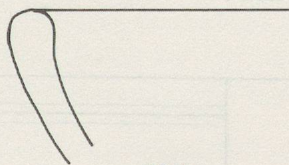

234

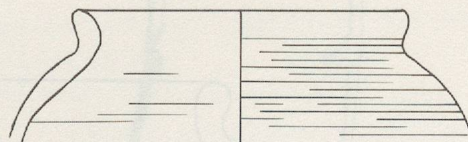

235

224 - 226 : TS. 227 : Imitation TS. 228 - 229 : Engobe interne rouge. 230 : Cruche. 231 : Céramique peinte.  
232 - 234 : Pâte claire. 235 : Pâte sombre. Ech. 1 : 2.

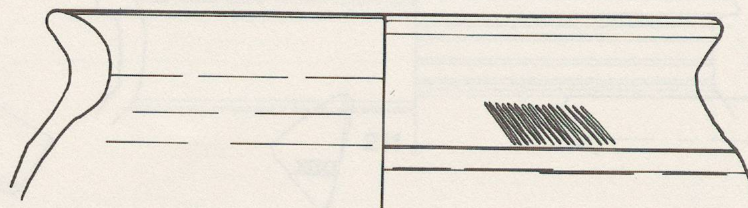

236 |

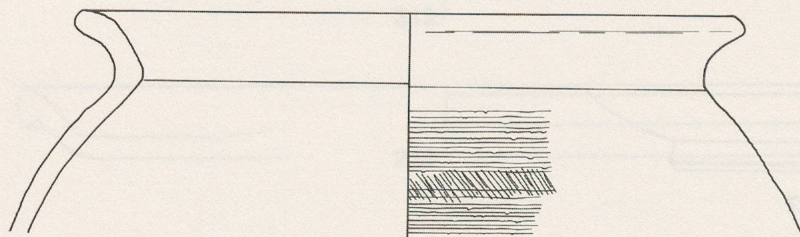

237 |

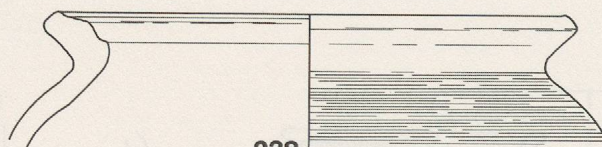

238 |

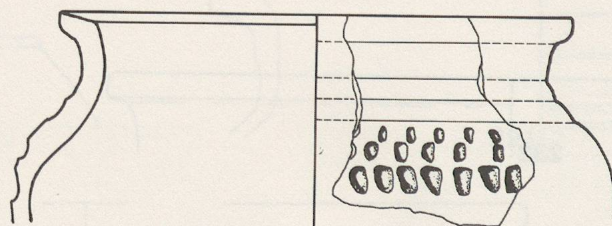

239 |

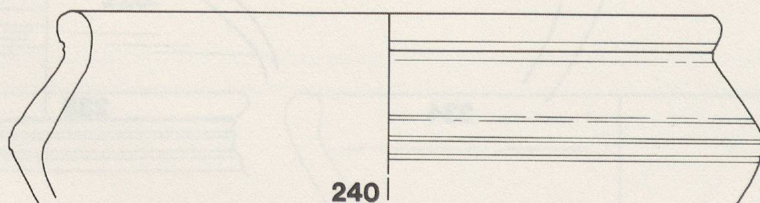

240 |

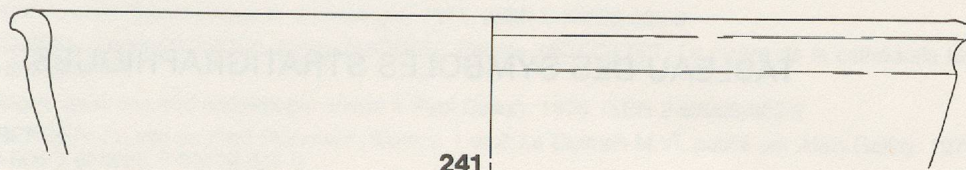

241

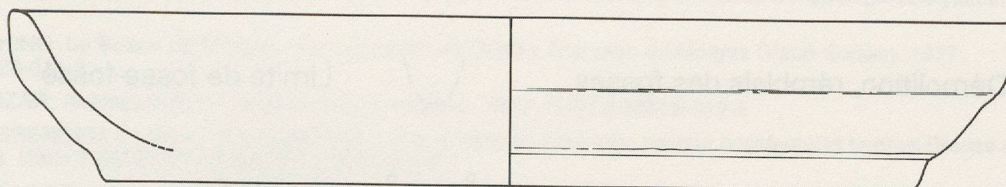

242

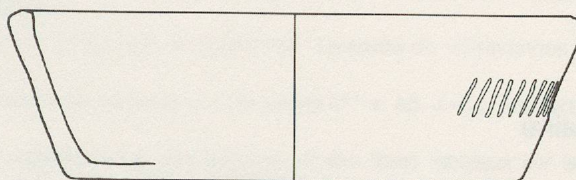

243

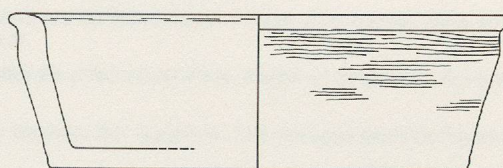

244



245

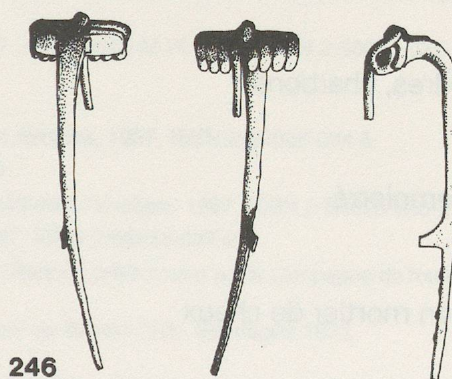

246

241 : 244 : Céramique à pâte sombre. 245 : Os. 246 : Bronze.