

Design evolution of the Tsing Ma bridge

Autor(en): **Simpson, Alan / Beard, Andrew / Young, Jeffrey**

Objektyp: **Article**

Zeitschrift: **IABSE reports = Rapports AIPC = IVBH Berichte**

Band (Jahr): **64 (1991)**

PDF erstellt am: **23.09.2024**

Persistenter Link: <https://doi.org/10.5169/seals-49351>

Nutzungsbedingungen

Die ETH-Bibliothek ist Anbieterin der digitalisierten Zeitschriften. Sie besitzt keine Urheberrechte an den Inhalten der Zeitschriften. Die Rechte liegen in der Regel bei den Herausgebern.

Die auf der Plattform e-periodica veröffentlichten Dokumente stehen für nicht-kommerzielle Zwecke in Lehre und Forschung sowie für die private Nutzung frei zur Verfügung. Einzelne Dateien oder Ausdrucke aus diesem Angebot können zusammen mit diesen Nutzungsbedingungen und den korrekten Herkunftsbezeichnungen weitergegeben werden.

Das Veröffentlichen von Bildern in Print- und Online-Publikationen ist nur mit vorheriger Genehmigung der Rechteinhaber erlaubt. Die systematische Speicherung von Teilen des elektronischen Angebots auf anderen Servern bedarf ebenfalls des schriftlichen Einverständnisses der Rechteinhaber.

Haftungsausschluss

Alle Angaben erfolgen ohne Gewähr für Vollständigkeit oder Richtigkeit. Es wird keine Haftung übernommen für Schäden durch die Verwendung von Informationen aus diesem Online-Angebot oder durch das Fehlen von Informationen. Dies gilt auch für Inhalte Dritter, die über dieses Angebot zugänglich sind.

Design Evolution of the Tsing Ma Bridge

Evolution de l'étude du pont Tsing Ma

Entwurfsprozess der Tsing-Ma Brücke

Alan SIMPSON

Director
Mott MacDonald Civil
London, UK

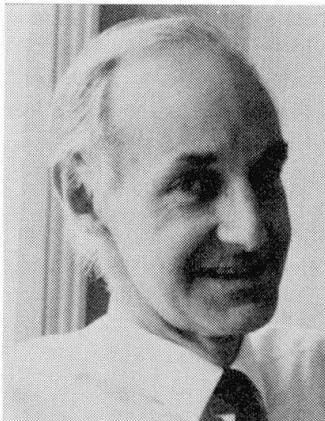

Andrew BEARD

Director
Mott MacDonald
Hong Kong

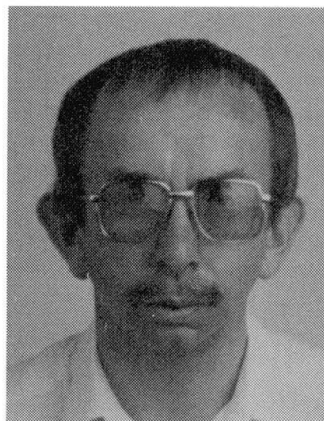

Jeffrey YOUNG

Associate
Mott MacDonald Civil
London, UK



SUMMARY

The need for a replacement airport in Hong Kong has required the development of new road and rail links. Three sea crossings are involved and the longest requires a 1377 m suspension span to be known as the Tsing Ma bridge. Typhoon winds of 300 km/h are expected at the site and the structure has been designed to resist the static and dynamic effects of these. Six lanes of traffic and two tracks of high speed mass transit railway will be accommodated on the bridge. This has had a major effect on the articulation and detailing of the suspended structure.

RESUME

Le besoin d'un aéroport de remplacement à Hong Kong a nécessité le développement de nouvelles liaisons routières et ferroviaires. Ceci implique trois liaisons sur la mer, dont la plus grande exige un pont suspendu de 1377 m, connu sous le nom de pont Tsing Ma. Des typhons de 300 km/h sont à prévoir sur les lieux et la structure a été dimensionnée pour résister à leurs effets statiques et dynamiques. Six voies routières et deux voies de métro express régional sont prévues sur ce pont. Ceci a eu un effet majeur sur l'articulation et sur les détails du pont suspendu.

ZUSAMMENFASSUNG

Der Bedarf eines Ersatzflughafens in Hong Kong hat die Entwicklung neuer Strassen- und Bahnverbindungen zur Folge. Drei Überquerungen des Meeres sind vorgesehen, wobei für die längste eine Hängebrücke mit einer Stützweite von 1377 m – die Tsing-Ma-Brücke – geplant ist. Taifune mit Windgeschwindigkeiten von 300 Stundenkilometern sind zu erwarten, weshalb die Struktur so entwickelt wurde, dass sie diesen statischen und dynamischen Einwirkungen widerstehen kann. Sechs Fahrbahnen und zwei Bahnlinien für eine Stadtschnellbahn sind für diese aufgehängte Brücke geplant, was einen grossen Einfluss auf die Verbindungsmittel und Konstruktionsdetails hat.



1. BACKGROUND TO THE PROJECT AND NEED FOR THE BRIDGE

The territory of Hong Kong consists of part of the South China mainland together with over 300 islands. The largest of these islands, Lantau, is sparsely developed with a small population. In the early 1970's the Government recognised the need for expansion in terms of new towns and a replacement airport. Lantau was selected as a potential site. A feasibility study into the "Lantau Fixed Crossing" was commissioned at the end of 1978 with the object of identifying the most suitable form of crossing between the mainland and Lantau island. As can be seen from Fig. 1, the route involved 3 sea crossings, the largest being of the order of 1500m in length. The requirement was to provide for 4 lanes of traffic with the possibility of expanding this to 6/8 lanes in the future. The recommended form for the larger crossing was a suspension bridge having a main span of 1413m to be known as the Tsing Ma bridge.

Following the feasibility study, a full detailed design was commissioned. During the development of the design it became apparent that the cross section selected for the deck would be suitable for double-deck construction and that either road or rail could be accommodated within the streamlined box section. Accordingly, the internal framing of the deck was designed as a Vierendeel truss so as to provide three longitudinal rectangular spaces in which a two-lane carriageway and two individual rail tracks could be accommodated. The lower carriageway would not normally be used but would provide a protected route, sheltered from high winds, during adverse weather conditions. This would ensure that the crossing remained open to traffic at all times – an important feature on a strategic link. This arrangement is shown on Fig. 2.

The detailed design was complete, ready for the invitation of tenders at the end of 1982. However, at that time a decision was taken to shelve the airport project. Tender invitation for the bridge was therefore postponed accordingly.

2. NEW REQUIREMENTS FOR THE 1990 SCHEME

Following postponement of the project, no further work was carried out until late 1989. At that time the Government had completed the "Port and Airport Development Strategy" studies which confirmed the replacement airport location as being on North Lantau at Chek Lap Kok. The studies gave greater emphasis to the need for a high speed rail connection between central Hong Kong and the airport. Revised road traffic forecasts indicated the need for dual 3-lane carriageways to be provided initially. Plans for other strategic highway links in the Territory had been developed to the extent that the Tsing Ma bridge required relocation about 700m south of the previous alignment. Also, the Tsing Yi north bridge had been constructed to form the first of the 3 sea crossings of the 1982 project. So far as possible, the Government required the redesign to follow the principles established previously.

The 1982 design had allowed for the incorporation of two tracks of mass transit railway but it had been anticipated that operating speeds would be of the order of 80 Km/h. The 1990 design required a high-speed rail link having an operating speed of 120 Km/h so as to provide a journey time of less than 25 minutes from Hong Kong Central to the airport.

The need to provide wider carriageways caused an increase in the overall width of the suspended deck and in the distance between the main cables from 30m to 36m. The greater internal width provided the opportunity to rearrange the rail tracks and carriageways. A more satisfactory operating arrangement for the railway was obtained by placing the tracks adjacent to each other along the bridge centreline. Two separate carriageways were provided, each 4.0m wide which was an improvement on the previous single 7.3m wide two directional carriageway. This rearrangement is shown in Fig. 4.

3. WIND EFFECTS GOVERNING THE DESIGN

Hong Kong lies on latitude 22° N and experiences the effects of severe tropical storms (typhoons). These storms produce winds of very high velocity at their centres. In the case of Tsing Ma bridge the 3s gust speed having a 200 year return period has been estimated at 83 m/s (300 Km/h). In terms of structural design, this has two important effects. Firstly the bridge must be designed to reduce static wind loading to a minimum (by shaping of the structural elements) and to have adequate strength to resist the wind forces. Secondly, it must remain dynamically stable in typhoon winds and not be susceptible to flutter instabilities.

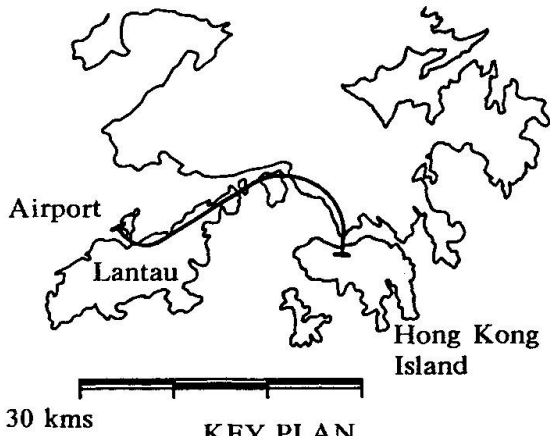

FIG. 1

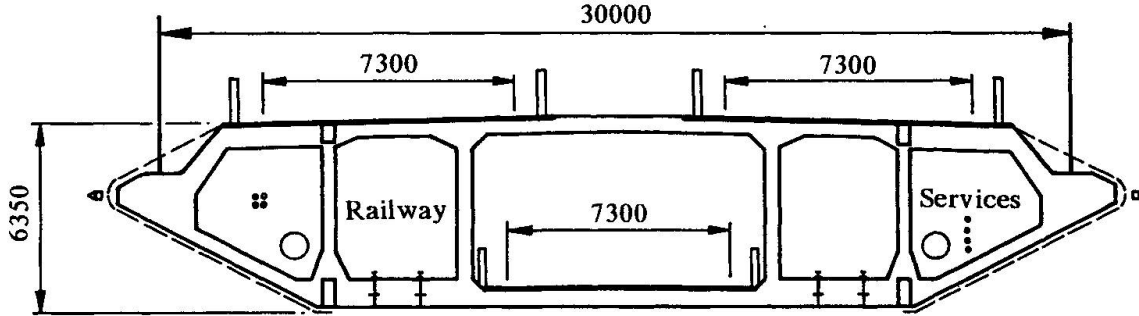
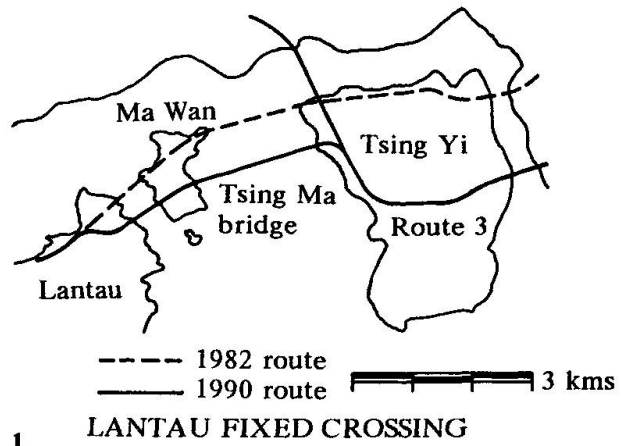

FIG. 2



FIG. 3

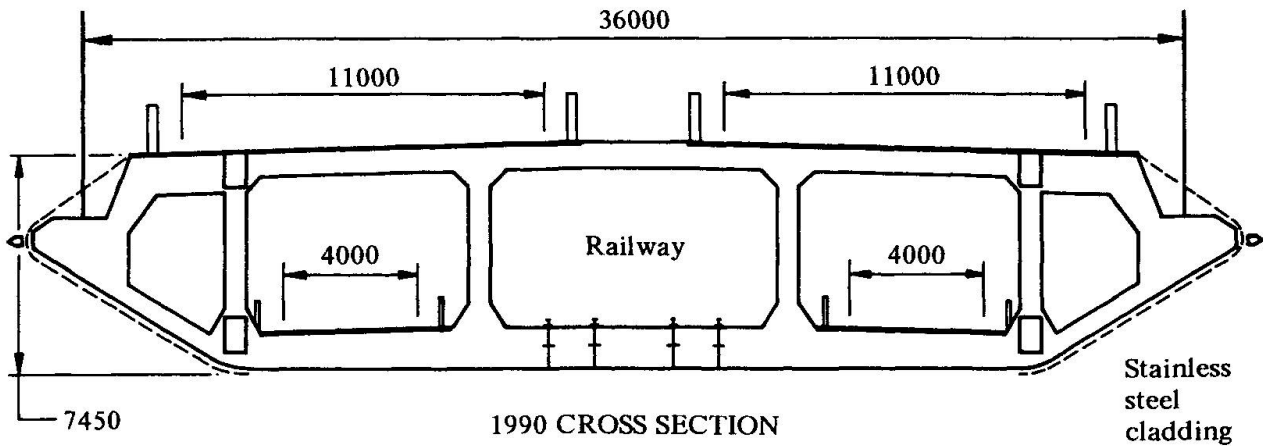

FIG. 4



It is well known that substantial reductions in drag forces can be achieved by fairing the edges of box girders. It is also well known that the critical windspeed for the onset of classical flutter instabilities can be raised by providing openings between adjacent horizontal surfaces (carriageways). European suspension bridges have been designed for maximum wind speeds of the order of 50 m/s. Faired (or streamlined) box girders have been shown to be stable at wind velocities up to 55 m/s. Following preliminary tests in 1978 it became apparent that a "ventilated" box girder could be developed which would be stable at all wind speeds up to the required value of 74 m/s. (the one minute mean windspeed $\times 1.2$). Testing was also carried out in winds inclined at angles up to $\pm 5^\circ$ from the horizontal. Further wind tunnel testing was carried out to determine the optimum arrangement of openings in the upper and lower surfaces of the box girder. The arrangement finally selected is shown in Fig. 3. Structurally, the deck is a hybrid solution combining both truss and box forms. The faired edges are made of non-structural cladding, this being the lightest form of construction in these locations.

Reduction of drag forces on the other structural elements can be achieved by shaping where possible. This is particularly relevant to the towers where it is desirable to reduce drag and to control vortex shedding in such a way that oscillations will not occur in the free-standing condition. This was achieved by rounding the ends of the tower legs.

The wind effects described above obviously applied to the redesigned bridge. However, because of the rearrangement of the internal spaces, it was necessary to reconsider the ventilation of the deck and to conduct confirmatory wind tunnel tests. These showed that the reduced central ventilation openings were satisfactory but that the steeper angles on the faired edges caused separation which led to instability in vertically inclined winds. Two solutions were possible, firstly to widen, and flatten, the edge slopes and secondly to introduce a turning vane at the edge of the carriageway. The more economic solution of a turning vane was selected.

4. RAILWAY EFFECTS GOVERNING THE DESIGN

The Hong Kong Government required a rail link to the airport which would provide a high standard of passenger comfort and convenience. Such a facility would be relatively straightforward to design for track on rigid supports. However, the flexibility of the suspension bridge required careful consideration of the rotations that would occur both in the vertical and the horizontal planes. The criteria adopted were as follows:-

- Desirable vertical radial acceleration not to exceed 0.03g
- Desirable horizontal radial acceleration not to exceed 0.05g

From these basic requirements, the maximum permissible rotations at each support were calculated and the proportions of the deck structure were adjusted to ensure they would be achieved under all relevant loading conditions. This was particularly important at the end support on the Tsing Yi side where a movement joint system would be installed. This would accommodate not only longitudinal movements but also vertical and horizontal rotations while permitting the passage of trains at normal operating speeds.

The articulation of the deck is such that a continuous girder is required for the full length of the bridge. The vertical and horizontal support points do not always coincide, thus allowing virtual fixity to be achieved at the ends with the minimum restraint forces. The articulation is shown on Fig. 5.

The second major effect of the railway loading is, of course, that due to fatigue. The high frequency of trains (3 minute intervals in each direction) leads to a very high cumulative axle tonnage (49×10^6 tonnes per annum compared to the UK value of 27×10^6). Whereas for normal suspension bridge construction it is the highway deck elements which are particularly prone to fatigue, in the case of a bridge carrying a railway the effects also occur in the rail bearers, crossframes and adjacent framing members. This naturally causes an increase in weight for the affected members but the overall structural dead load of the suspended structure amounts to 2.4 tonnes/m/equivalent-traffic-lane. This figure compares favourably with other long span bridges which carry either highway traffic alone or highway and railway traffic.

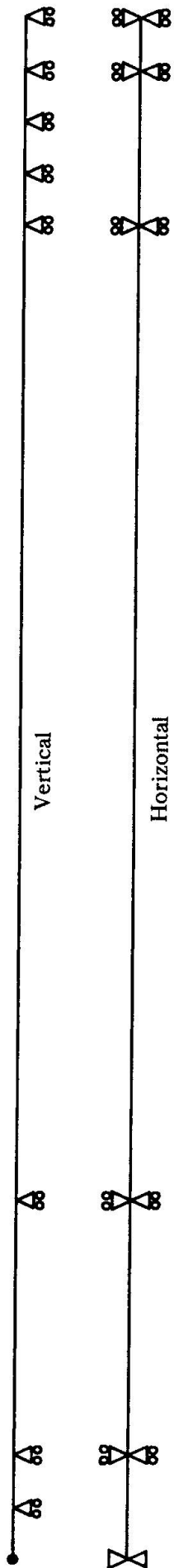

ARTICULATION

FIG. 5

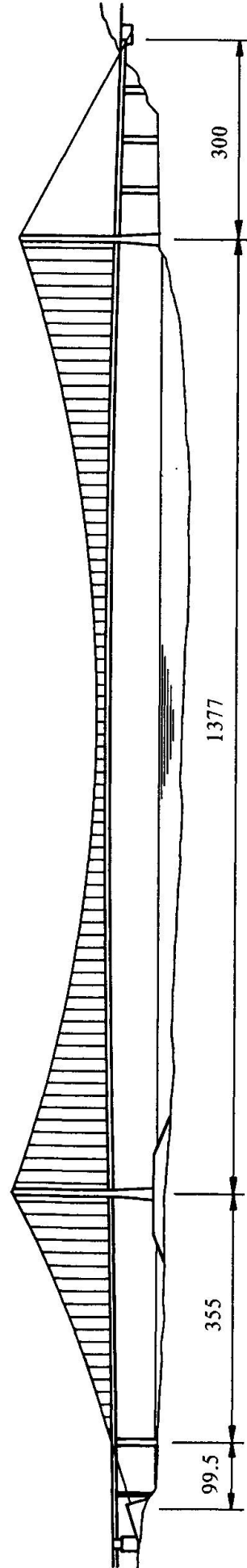
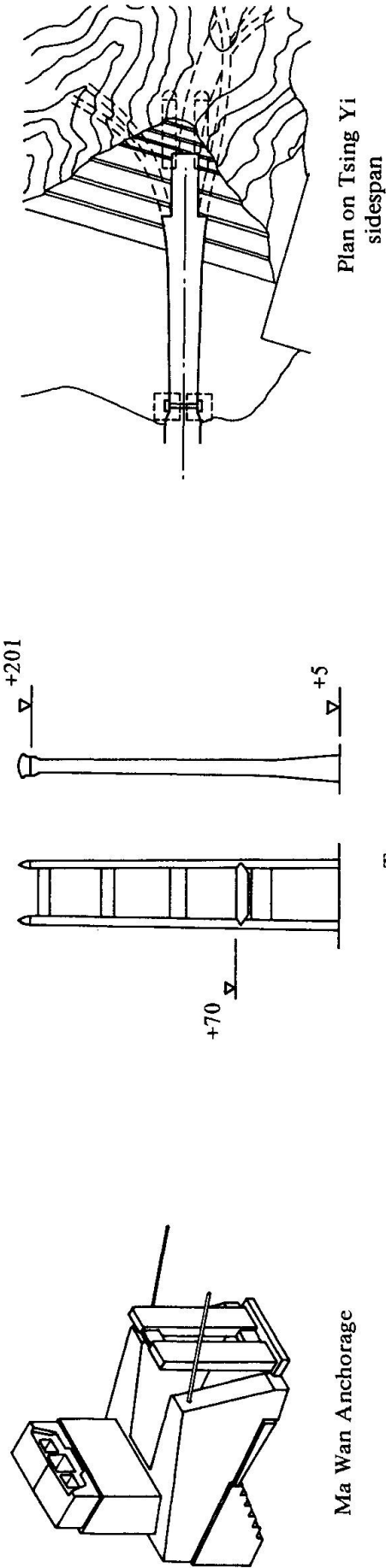

GENERAL ARRANGEMENT

FIG. 6



5. GENERAL DESCRIPTION OF THE BRIDGE

Relocation of the bridge resulted in a slight reduction of the mainspan to 1377m. On the Ma Wan end there is a suspended sidespan of 355m and approach spans of 80m and 48m. On the Tsing Yi end there is a straight backstay cable below which there are four approach spans of 72m each. This arrangement provides comparatively rigid ends to the deck system.

The navigation channel has a width measured along the bridge centreline of approximately 1070m. A vertical headroom of 59.5m above mean high water is provided.

The towers will be of reinforced concrete construction, thus providing the possibility of an early start to construction. The legs of each tower incline towards each other at a slope of 1:100. Bracing between the legs takes the form of four rectangular portal beams which will be post-tensioned. The Tsing Yi tower has been placed onshore to minimise the ship impact protective measures that will be required. A rock fill island will protect the Ma Wan tower which is located in shallow water.

It is anticipated that the main cables will be constructed from preformed parallel wire strands. Each cable will consist of 291 strands of 127 No. 5mm diam. wire having a compacted diameter of approximately 1100mm. The backstay cables on the Tsing Yi side will each have an additional 16 strands.

The cable anchorage on the Ma Wan side will be of concrete gravity construction situated on the island foreshore. At the Tsing Yi side, each cable will terminate in a tunnel anchorage formed in the hillside.

The Tsing Yi end of the bridge is largely controlled by the presence of Route 3, a major expressway which acts as the primary traffic link to Hong Kong Central. Slip roads associated with the Lantau Fixed Crossing/Route 3 interchange necessitate the provision of upper carriageways which widen progressively east of the tower. This precludes a suspended sidespan because the hangers would conflict with the carriageways. A four span supported deck structure, continuous through the tower, has been provided.

The bridge will form part of the only fixed transport link to the airport for many years. It is, therefore, an essential requirement that road traffic should be able to use the bridge at all times. For this reason, two lower carriageways have been provided within a "sheltered" location in the deck structure so that traffic can continue to use the bridge during periods of high wind. Wind Tunnel measurements have established that the internal windspeeds will be approximately 40% of the external windspeed.

The suspended structure consists of two longitudinal trusses which act in conjunction with the orthotropic plates of the carriageway decks. The trusses are positioned to coincide with the outer vertical members of the Vierendeel crossframes. At the towers and in the end spans, additional trusses are introduced at the inner vertical members. The trusses are of conventional box chords with I-section verticals and diagonals. The top flange of the top chord is integral with the upper carriageway deck plate. Crossframes occur at 4.5m centres and coincide with the truss verticals. The suspended structure is supported at every fourth crossframe. Transverse shear is carried by the deck panels and by plan diagonal bracing across the upper and lower level openings. Each rail track is carried on bearers which consist of two beams having a common top flange plate. The sloping sides of the structure are made of profiled stainless steel sheeting.

Fig. 6 indicates the general arrangement of the bridge.

6. ACKNOWLEDGEMENT

The authors wish to express their thanks to the Director of Highways, Mr. S.K. Kwei, for permission to publish the paper and to the staff of the Highways Department, in particular Mr. K.S. Leung, Government Engineer and Mr. C.K. Lau, Chief Engineer (Structures) for their contribution towards the development of the design.