

Session 4: a) Joints, bearings and other details; b) Financial and planning considerations

Objektyp: **Group**

Zeitschrift: **IABSE reports = Rapports AIPC = IVBH Berichte**

Band (Jahr): **39 (1982)**

PDF erstellt am: **25.09.2024**

Nutzungsbedingungen

Die ETH-Bibliothek ist Anbieterin der digitalisierten Zeitschriften. Sie besitzt keine Urheberrechte an den Inhalten der Zeitschriften. Die Rechte liegen in der Regel bei den Herausgebern.

Die auf der Plattform e-periodica veröffentlichten Dokumente stehen für nicht-kommerzielle Zwecke in Lehre und Forschung sowie für die private Nutzung frei zur Verfügung. Einzelne Dateien oder Ausdrucke aus diesem Angebot können zusammen mit diesen Nutzungsbedingungen und den korrekten Herkunftsbezeichnungen weitergegeben werden.

Das Veröffentlichen von Bildern in Print- und Online-Publikationen ist nur mit vorheriger Genehmigung der Rechteinhaber erlaubt. Die systematische Speicherung von Teilen des elektronischen Angebots auf anderen Servern bedarf ebenfalls des schriftlichen Einverständnisses der Rechteinhaber.

Haftungsausschluss

Alle Angaben erfolgen ohne Gewähr für Vollständigkeit oder Richtigkeit. Es wird keine Haftung übernommen für Schäden durch die Verwendung von Informationen aus diesem Online-Angebot oder durch das Fehlen von Informationen. Dies gilt auch für Inhalte Dritter, die über dieses Angebot zugänglich sind.

SESSION 4

- a) Joints, Bearings and Other Details**
- b) Financial and Planning Considerations**

- a) Joints, appuis et autres équipements annexes**
- b) Aspects financiers et planification**

- a) Fugen, Auflager und andere konstruktive Elemente**
- b) Finanzielle Aspekte und Planung**

Leere Seite
Blank page
Page vide

Bridge Deck Expansion Joint Transition Areas

Réparation des zones proches des joints de dilatation de ponts

Instandsetzung der Fahrbahnübergangsbereiche bei Brücken

Stewart C. WATSON

President
Watson Bowman Associates Inc.
Getzville, NY, USA



Stewart Watson has been involved in the design of joints and installation of kinematic devices of bridges and structures for over 40 years. A Fellow of ACI, he serves on numerous TRB, ASTM and ACI Technical Committees including chairmanship of ACI Committee 554 (Bearing Systems).

SUMMARY

It has become apparent during the past decade on primary highway-bridge systems throughout the world that the wearing surface area and that structural portion of bridge decks directly underneath the surface which are adjacent to deck discontinuities tend to deteriorate under traffic loading and service conditions at a much faster rate than the main portion of the deck itself. This discussion will outline reasons for this phenomenon and describe recently developed materials and rehabilitative methodology that will operate towards extending the maintenance free life of this critical area of bridge decks.

RESUME

La surface de roulement et la partie de la structure de tabliers de ponts proches des joints, se détériorent plus rapidement sous l'effet du trafic et des conditions de service que la partie principale du tablier. L'article explique les raisons du phénomène et décrit les matériaux récents et les méthodes de réparation permettant de prolonger la période sans entretien de ces zones critiques de tabliers de ponts.

ZUSAMMENFASSUNG

Während des letzten Jahrzehnts zeigte sich in der ganzen Welt, dass sich der Zustand der Brückenfahrbahnplatten in der Nähe der Fahrbahnübergänge unter Verkehrslast viel schneller verschlechterte, als im ungestörten Bereich der Platte. Der Beitrag zeigt die Gründe für diese Erscheinung auf und beschreibt neu entwickelte Materialien und Instandstellungsmethoden, die die Lebensdauer dieser kritischen Bereiche verlängern und den Aufwand im Unterhalt herabsetzen.



1. INTRODUCTION

The ever recurring necessity to rehabilitate bridge expansion joints and the rapidly escalating cost of doing so in the face of continuing and spiraling inflationary pressures is becoming a serious problem for transportation engineers the world over.

The United States Federal Highway Administration in its March 1982 Highway Bridge Replacement & Rehabilitation Program report to the Congress of the United States advised that nearly one out of every two of the nation's 557,516 bridges are structurally deficient. The list is growing very rapidly and today 248,527 of these structures are substandard. This alarming statistic is being reflected in numerous bridge jurisdictions around the world.

As a result of this, life cycle cost thinking (the sum of first costs and in-service expenditures) is beginning to surface in the form of specifications which attempt to describe materials, methods of construction and rehabilitation which will either eliminate or greatly minimize the necessity for maintenance. To advance the state of the art requires an examination of the fundamentals involved, on a bridge by bridge basis, if we are to extend the maintenance free life of expansion joints which by far have been the major contributing factor to the early demise of bridges. It is also obvious that there is a critical need for some new materials and practices to take the place of the devices and systems which result in leaking joints, deteriorating interfacial joint surfaces, and dams which undergo premature post-installation cracking, eroding and spalling, or those that tend to break down under repetitive loading, snow plows, studded tires, chains and that in-service environmental chemistry peculiar to bridges.

This paper includes judgments that are the result of intensive investigational work and experience with bridge expansion joints over the past couple of decades including a time lapse analysis of numerous on-site photographs taken over this period of time as environmental and service conditions have taken their toll of performance of expansion joints.

1.2 Transition Area Defined

For purposes of this discussion, the commonly understood "end dam" or "nosing" component of the expansion joint is synonymous with and may be termed the "transition" area. That many of the materials in common usage today in the transition area have proven themselves historically to have short term performance capabilities is the subject of this report.

2. DESIGN GOAL

Using many present expansion joint materials and systems, the hoped for 50-80 year design service life idealized for bridges may be an impractical goal since less than 3 years is all that is necessary for many types of end dam components to fail. There is an apparent inability of certain types of end dam components to maintain any semblance of structural reliability for even the short term. It has also become apparent there is a need for a transition material to bridge the gap between the structural performance requirements of the main portion of the bridge deck and the expansion joint itself which in terms of dynamics are vastly different. For a split portion of a second, a heavy truck or lorry passing over a joint at high speed becomes partially airborne with the impact effect applied to the opposing joint interface taking its toll of structural life.



If one adds to this the impact effect at lowered temperatures upon the anchorage, expansion bolts, adhesives and the materials normally used in expansion joints when under tension in a contracted state, there is an obvious need for a re-examination of what types of materials could have a lengthening effect on service life.

With many expansion joints being hybrid devices comprised of materials with widely different expansion coefficients, hardnesses, energy assimilating capabilities and adhesive properties, it is postulated that the transition area of the bridge deck should comprise a forgiving material that will be compatible with these inherently differing properties so that they will not of themselves self-destruct under normal conditions of service.

3. PRESENT FAILURE MODES - MATERIALS & PRACTICES

3.1 Exotic Cements and Mortars

Epoxy mortars have excellent properties in the laboratory as adhesives but as an expansion joint end dam, they have proven rather conclusively that they cannot retain their structural integrity for lengths greater than 3 feet (1 m) in the classical end dam configuration. Pure epoxies have an expansion coefficient in the magnitude of 10 times greater than steel or concrete and while this can somewhat be ameliorated by aggregate loading, for all practical purposes they are incompatible for use in the transition area. They exhibit low tensile strength in the medium to high temperature ranges, significantly reduced strengths at lowered temperatures and are basically non-energy absorbing. Add to this problems in installation such as exotherm boiling, bond shear failures due to volume changes from thickness exotherm, plus mixing, proportioning and moisture complications and you can understand their early demise in deck transition areas.

3.2 Magnesium Phosphate Dams

Extensive failures of this type of exotic mortar when used in the classical end dam configuration appear to indicate that they may be incompatible when used with expansion joint devices. They have wide disparities in expansion coefficients prior to aggregate loading by a factor of 10 times as compared to the base deck concrete and it has been suggested that placing such hard brittle mortars in this environment is likened to "pouring glass on top of concrete" [1].

3.3 Polymer Concrete End Dams

In at least one comparison field test now 3 years old, polymer concrete end dams exhibited a disappointing service record. Donnaruma [2] in his report to the 1981 World Congress on Expansion Joints & Bearings concerning a controlled test environment on the Tappan Zee Bridge near New York City, elaborates on its high potential towards premature cracking under the 100,000 vehicle per day traffic density of this structure, 25% of which are trucks.

3.4 Portland Cement End Dams

It is the nature of Portland Cement when used in the shape of an end dam to exhibit longitudinal cracking initially at about 3 feet (1 m) intervals in similarity to epoxies, magnesium phosphates, and other exotic mortars. In the passage of time and temperature cycling, intermediate cracks continue to occur after which broken segments tend to work out under traffic loading. For this reason alone, it is an unsuitable material for use as a concrete end dam where leakproofing is the criteria.



3.5 Asphaltic End Dams

It would probably be safe to say that the "buried joint" or asphaltic transition dam concept which has seen extensive usage all over the world in every conceivable type of environment has been responsible for maintenance resurfacing costs to bridge decks beyond all calculation.

In the present state of the art, there exists no field-proven method of eliminating the inevitable crack or rip in the wearing course as time, temperature cycling and loading gradually break down the asphalt. This is much more quickly demonstrated in low temperature environments when the glasslike properties of asphalt when being stretched over a joint while in the contracted state becomes apparent.

3.6 Metallic Dams Cast-in-Place

While metallic dams which are cast-in-place monolithic through the deck from curb to curb are more desirable than those placed in segments, which tend to cause reflection cracks at junctures, they still are plagued with problems caused from differential movement coefficients, consolidation of concrete under flat members plus corrosion and weld fatigue failures of the anchorages which cause them to rock and work under live loads. Segmental metallic dams which are bolted in place are particularly troublesome and prone to becoming loose, a problem much in evidence on high truck density structures.

3.7 Corrosion Bursting of Expansion Joint Anchorages

Not unlike the problem of bridge decks which have a demonstrated propensity for premature failure due to purpose applications of chloride, acid rain and environmental chemistry which also tends to accumulate on the expansion joint, the embedded metals which comprise the expansion joint anchorage have the exact same problem. The use of elastomeric concrete eliminates the problem of anchorage corrosion completely since the electrolytic process necessary to oxidic degradation of base metals is totally occluded by embedment in an impervious rubber structure. As the use of elastomeric concrete continues to escalate, and costs by reason of volume usage declines, it is surmised that the entire bridge deck surface or wearing course will become a candidate market area because its properties appear to be ideal for the service requirements of a crack free impervious wearing course.

3.8 The As-Placed Temperature Problem

Since there are wide variations and constantly changing diurnal deck temperatures from early morning to mid-day to evening, the problem of placing exotic mortars, magnesium phosphates and epoxy systems which have widely differing expansion coefficients than the previously placed deck concrete, can have a large effect on their ability to remain crack free. It would be pure luck if an epoxy mortar, which has a 6 times greater coefficient of expansion than the base concrete it is positioned upon, was placed when the air temperature, deck temperature and the epoxy temperatures were similar.

Obviously the greater the temperature disparity between the deck and the end dam matrix as placed, the greater the tendency to longitudinal cracking since the two materials would be out of phase. Since there is no truly reliable means of taking a bridge deck temperature nor is there in fact any one single temperature throughout the mass of a bridge deck, it would be desirable to use something forgiving or elastic in this environment that could remain crack free regardless of these uncontrolled temperature differentials at time of placement.

4. PERFORMANCE CRITERIA FOR A TRANSITION DAM

Based on the heretofore described problem areas for transition dams, the following performance criteria seems indicated for an idealized transition dam:

- 1) It must be capable of being installed in one monolithic section for idealized leakproofing, extending throughout the impact area of the deck.
- 2) It must comprise an energy absorbing matrix to attenuate and absorb within itself anticipated impact loads.
- 3) Fastening it to the deck end must be achievable with a high degree of permanency.
- 4) An intimate impervious mating of the dam to the deck and adjacent wearing course is desirable to prevent rocking under live loads.
- 5) The end dam must be compatible with adjacent materials so as to preclude differential shrinkage or expansion movement and shearing.
- 6) The material should resist attrition, spalling, cracking or breaking down under impact and wear.
- 7) It should be chemically inert to typical bridge deck chemicals such as chlorides, sulphuric acid, the chemistry of acid rain, sunlight, soil bacteria, animal wastes and effects of ultra violet or ozone.
- 8) It must remain flexible and structurally sound during extremes of high and low temperatures.
- 9) It must seal out the entry of deleterious chemistry into the anchorage and fastening components.
- 10) All vertical and horizontal directional changes in the line of the expansion joint and all junctures resulting from lane-at-a-time rehabilitation requirements must be imperviously sound and structurally the equivalent of the main portion of the transition area.

5. THE DEVELOPMENT OF ELASTOMERIC CONCRETE AS A TRANSITION DAM

By en large due to the aforementioned expansion joint transition area problems, experimentation began in the early 70's in France with a new type of material which incorporates the desirable structural properties of sound concrete but also a fundamental elastomeric or rubberlike nature as well. Prior to 1970, the Boulevard Peripherique which encircles the City of Paris with its record truck traffic volume was experiencing intensive breakout failures of its expansion joints. In spite of a husky anchorage specification requirement of 7 tons per foot (20,834 kg/m) of bolt prestressment, heavy truck traffic was knocking out expansion joints en masse in less than 5 years of service. Experimental rehabilitation installations of joints utilizing a new type of material for transition areas, the generic description of which is "elastomeric concrete", which were installed in 1972 are still performing with excellence, apparently unaffected after over a decade of service in one of the world's most high density truck traffic environments. Since then extensive installations of elastomeric concrete have seen successful use in France and in a number of other countries including U.S.A. and Canada. The oldest installations are still structurally sound, have proven to be totally devoid of cracks as well as maintenance free and cost effective.

6. ENGINEERING PROPERTIES OF ELASTOMERIC CONCRETE

Extensive laboratory testing of elastomeric concrete reveals that it has an exceptionally high bond strength to concrete, asphalt and steel not only at room temperature but also high and low temperature exposures. Its rubberlike properties tend to negate the effect of live load impact stresses and absorb them like a vibration damper. It reacts to hammer blows similar to that of a rubber bearing pad and has the field demonstrated capability of remaining crack free in the typical end dam configuration for the life of the installation.



7. INSTALLATION OF ELASTOMERIC CONCRETE

The work process for elastomeric concrete minimizes rehabilitation time and effort. Vulcanization time depending upon ambient temperature is approximately 2 hours after which it may be opened to full design traffic loading. There is no interference with asphaltting operations nor is there a necessity to remove deck concrete or drill into existing concrete.

The problem of drilling for anchorage bolts wherein embedded prestressment cables, hardware or reinforcing bars might be in jeopardy has been eliminated. Live load impact stress is distributed and attenuated throughout the mass of an elastomeric concrete dam. Corrosion of the expansion joint anchorage is eliminated because it is embedded in a mass of impervious rubber.

Since it is required that very high quality rubbers are used, a mobile field unit is utilized to field mix and blend a multicomponent mixture of vulcanizable elastomeric ingredients together with clean graded and powdered aggregates. These different components must be individually elevated and held at predetermined differential temperature gradients immediately prior to placement and field vulcanization.

Field vulcanization follows after placement by means of covering the expansion joint area with segmental heat chambers. The expansion joint system is heat fusion bonded to the subdeck as a by-product of elevated temperatures necessary to vulcanizing for a 2 hour period of time. The result is a monolithic, energy absorbing, permanently crack and spall free, impervious expansion joint and dam which has a long service life capability in the heaviest of truck traffic environments.

8. CONCLUSION

Present generation end dams or transition areas of bridge decks have tended to have a short performance life particularly in high density traffic environments. Elastomeric concrete with over a decade of performance history offers a new tool for the bridge designer of expansion joints to extend the maintenance free life of his structure.

REFERENCES

- 1) BUSCH, GARY A., Experience with Elastomeric Concrete Expansion Joint Transition Solutions, American Concrete Institute, 1981.
- 2) DONNARUMA, R. C., Joint Reconstruction on the Tappan Zee Bridge, American Concrete Institute, 1981.

Aging of High Strength Bolted Joints in Long Service

Vieillissement des assemblages avec des boulons à haute résistance

Die Alterung von HV-Schraubenverbindungen

Akira NISHIMURA

Professor
Kobe Univ.
Kobe, Japan

Akira Nishimura, born in 1927, got his doctor's degree in 1961 at Kyoto Univ., now a professor of structural engineering.

Jiro TAJIMA

Professor
Saitama Univ.
Saitama, Japan

Jiro Tajima, born in 1925, got his doctor's degree in 1964 at Tokyo Univ. He was engaged in the design of bridges for 30 years, now a professor of Construction Engineering.

Tokuya YAMASAKI

Technical Adviser
Kawasaki Steel Corp.
Chiba, Japan

Tokuya Yamasaki, born in 1922, got his doctor's degree in 1962 at Kyushu Univ. He was a professor of civil engineering at Kyushu Univ. for 10 years, now a technical adviser of Structure Research Laboratories.

Shunso KIKUKAWA

Senior Researcher
Kawasaki Steel Corp.
Chiba, Japan

Shunso Kikukawa, born in 1948, got his Master's degree at Osaka Univ., now a senior researcher of Structure Research Laboratories.

SUMMARY

This paper reports the investigation on the aging of slip load and bolt tension of friction type high strength bolted joints of two bridges, one building and two types of joint models. Obtained conclusions are: In the joints of blasted plates, the slip loads were improved through aging. In the joints of coated plates, the slip loads were in firm through aging and in the joints of the above, the allowable shearing stress of a bolt is desirable to be lowered based on statistical estimation taking maintenance into consideration.

RESUME

Des recherches ont été effectuées sur le vieillissement et sur la force de glissement et la tension dans les boulons de deux types d'assemblage au moyen de boulons à haute résistance, dans le cas de deux ponts et d'un bâtiment. Dans les assemblages de tôles sablées la résistance au glissement augmente avec les années, tandis que dans les assemblages de tôles traitées, la résistance au glissement ne change pas dans le temps. Il est cependant recommandé d'abaisser la contrainte admissible pour les boulons en tenant compte de l'entretien.

ZUSAMMENFASSUNG

Die vorliegende Untersuchung befasst sich mit der Alterung von gleitfesten Schraubenverbindungen. Es wird das Zeitverhalten der Kraftübertragung über Reibung sowie der Spannungen in der Schraube dargestellt. Die Untersuchung erfolgt an Brücken-, Hochbau- und Modellverbindungen. Die erhaltenen Ergebnisse in Abhängigkeit der Alterung sind folgende: Bei sandgestrahlten Verbindungen erhöht sich der Widerstand. Bei beschichteten Oberflächen blieb der Reibungswiderstand konstant. Die zulässigen Schraubenspannungen könnten aufgrund statistischer Überlegungen reduziert werden, unter Einbezug der Unterhaltsaufwendungen.



1. INTRODUCTION

More than thirty years have passed away since high strength bolted friction type joints began to be used for many steel structures such as bridges and building constructions. During this period, many works have been published on researches and investigations concerning the slip resistance of the joints and relaxation of high strength bolts [1], but investigations about secular changes in the strength of the joints have been extremely rare. It is important to find out quantitatively the changes in the strength of joints, when maintenance of the friction joints are to be considered.

The present study investigated the quantitative characteristics of aging in mechanical properties of friction joints by using joints of actual constructions as well as model specimens, and made statistical considerations on the reliability of the joints against slipping load.

2. TEST PROGRAM

Table 1 shows the details of investigated joints. Series A and B are the joints in highway bridges currently in use. Residual tension of high strength bolts was measured at the web splices of the floor beam (15 years have passed) for series A, and at the web splices of the main box girder (4 years have passed) for series B. Bolt tension and joint slip load 4 years after construction in series C were investigated at the lattice joints (Fig. 1) of large-span trussed frames. For series D, bolt tension and slip load 13 years after assembling were measured by using model joints shown in Fig. 2. In series E, the model joints having similar shapes to that shown in Fig. 2 and coated faying surfaces were used to investigate joint behaviors 1 year and 3 years after assembling.

For surface coating, inorganic zinc-rich paint coating and zinc metallizing were used. Series A to D were the joints of blasted faying surfaces in ordinary use.

Plate materials used for these joints were JIS G 3101 SS41 (required tensile strength: $\sigma_u \geq 402.1$ MPa) and JIS G 3106 SM50 ($\sigma_u \geq 490.3$ MPa). Bolt materials used were JIS B 1186 F9T, F10T and F11T ($\sigma_u \geq 882.6, 980.7$ and 1079.0 MPa, respectively).

These bolts were tightened by the calibrated wrench method, turn-of-nut method [2] and slope detecting method [3] which are commonly used now in the United States and Japan.

Table 1 Tested Joints

Test Series	Joints	Time Elapsed	Faying Surface of the Joints	Bolt Tightening Method	Type of Bolts	Type of Steel
A	Composite Girder Bridge Bridge Length : 1,350 m Width : 7.0 m	15 yrs.	Shot Blasted	Calibrated Wrench Method	JIS B 1186 F11T 7/8-in.	JIS G 3106 SM50
B	Box Girder Bridge Bridge Length : 443.8 m Width : 28.3 m	4	Shot Blasted	Slope Detecting Method	F10T M22	SM50
C	Trussed Gabled Frame Span 79.2 m × Depth 86.4 m Height : 55 m	4	Shot Blasted	Slope Detecting Method	F10T M20	SM50
D-1	Model Specimen	13	Shot Blasted	Calibrated Wrench Method	F9T 5/8-in.	JIS G 3101
D-2	Model Specimen	13	Shot Blasted	Turn of Nut Method		SS41
E-1	Model Specimen	1	Coated with Zinc-Rich Primer	Calibrated Wrench Method	F11T M22	SM50
E-2	Model Specimen	3	Zinc Metallized			



Bolt tension was (1) estimated by the use of gages at the head or shank of the bolt for series A, B, C and E, or (2) calculated from changes in the bolt length measured with a micrometer after releasing the nut for series D.

Slip tests were conducted for series C, D and E. The joint slip was determined by relative displacements measured with clip gages set between the main plate and the splice plate of the joint.

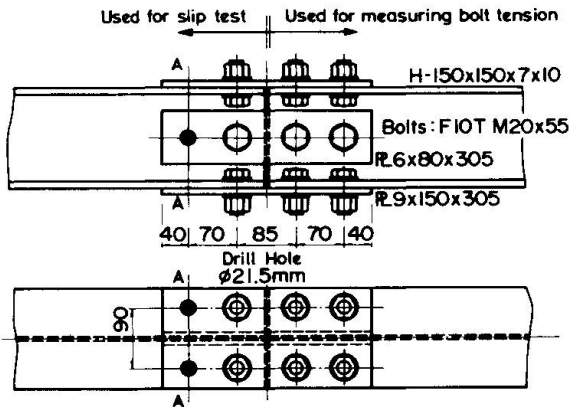

Note: A half number of bolts (5 bolts) in A-A were loosened before slip tests.

Fig. 1 Tested Joint for Series C

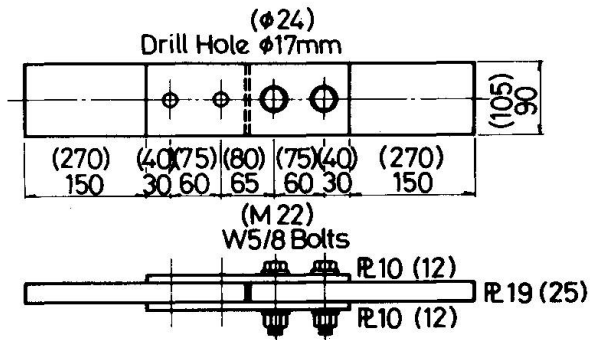

Descriptions in parentheses show those of series E.

Fig. 2 Tested Joints for Series D and E

3. RESULTS AND DISCUSSIONS

3.1 Aging in Bolt Tension

Table 2 shows the results of bolt tensions measured immediately after installation and after various long durations. Fig. 3 shows the reduction of bolt tension against that of immediately after installation. Furthermore, Fig. 3 shows the past test data [4] which were obtained when F8T, F10T and F11T bolts were tightened by the turn-of-nut method. From these test results, it has been concluded that the reduction of bolt tension after long duration is about 20% regardless of the differences in the tightening methods, kind of bolt sets and steel grade of joints, or in the faying surface conditions with or without coatings.

Table 2 Comparison of Bolt Tensions

Test Series	At Installation			After Long Duration			Time Elapsed (yrs.)
	Bolt Tention (kN)		Number of Bolts	Bolt Tention (kN)		Number of Bolts	
	Mean	St. Dev.		Mean	St. Dev.		
A	227.5	—	—	183.4	22.36	16	15
B	270.7	3.628	5	236.3	10.20	24	4
C	229.9	8.041	56	196.0	15.40	96	4
D-1	88.3	5.296	7	65.7	9.414	15	13
D-2	133.4	0.785	4	95.1	19.25	24	13
E-1	233.1	0.422	10	195.1	3.256	10	1
				197.7	2.893	6	3
E-2	233.1	0.373	10	199.4	5.658	10	1
				202.5	3.521	6	3

1) Calculated based on a torque-bolt tension relationship



3.2 Aging in Slip Resistance

Table 3 shows the results of slip loads obtained by slip tests conducted 24 to 48 hours after installation and after long duration. It is clearly shown that the slip load of surface blasted joints increases as the years pass. The slip load of surface coated joints showed two types of results, i.e., a gradual decrease 3 years after installation for series E-1 and conversely a slight increase for series E-2.

Therefore, a great increase in slip load after the passage of several years may not be expected for the surface coated joints.

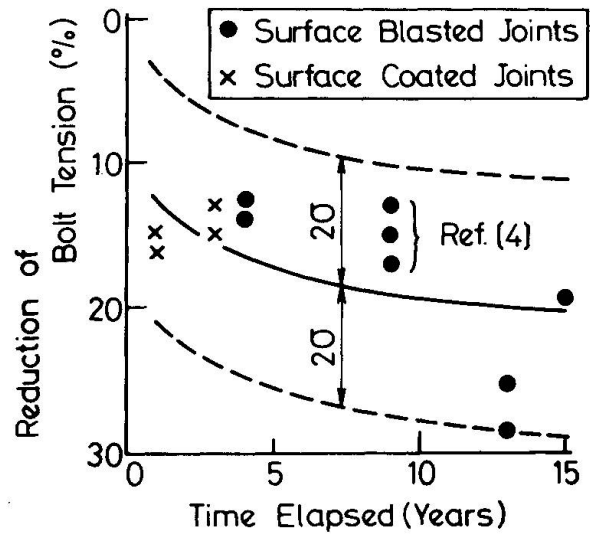

Fig. 3 Aging in Bolt Tensions

Table 3 Slip Test Results

Test Series	At Installation					After Long Duration					
	Slip Load (kN)		Slip Coefficient		Number of Tested Joints	Slip Load (kN)		Slip Coefficient		Number of Tested Joints	Time Elapsed (yrs.)
	Mean	St. Dev.	Mean	St. Dev.		Mean	St. Dev.	Mean	St. Dev.		
C	635.0	—	0.46	—	1	744.0	55.48	0.63	0.056	10	4
D-1	210.7	15.29	0.60	0.044	7	233.2	22.39	0.89	0.086	7	13
D-2	303.0	20.59	0.57	0.039	7	348.5	14.64	0.88	0.079	7	
E-1	450.9	18.67	0.48	0.020	10	419.1	24.15	0.54	0.031	5	1
						419.1	35.66	0.53	0.053	5	3
E-2	491.1	19.61	0.53	0.021	10	487.2	13.85	0.61	0.018	5	1
						522.0	40.91	0.64	0.050	5	3

The slip coefficient μ which is governed by the condition of the faying surface and bolt tension is generally defined by the following equation:

$$\mu = \frac{P}{f \cdot \sum_{i=1}^n B_i} \dots \dots \dots (i)$$

- where P : slip load
- f : the number of faying surfaces
- n : the number of bolts
- B_i: the i-th bolt tension

The slip coefficients in Table 3 were calculated from eq. (i) on the basis of the values of slip load and bolt existing tension of respective joints. This table indicates that a great increase in the slip coefficient may be expected after long duration for the surface blasted joints. As far as the present tests were concerned, the rate of increase were 40 to 50% for the surface blasted joints. On the other hand, for the surface coated joints, the slip coefficient after long duration shows no great difference from that at the initial stage. It can

be said, therefore, that the surface coated joint is more liable to cause slip after long duration than the surface blasted joint, if the reduction in bolt tension due to relaxation is taken into consideration.

3.3 Reliability of Bolted Joint in Long Service

On the assumption of normal distribution, $N(m, \sigma)$ about P , μ and B , the mean value of m_p of P and standard deviation σ_p are defined by the following equations:

$$m_p = m_\mu \cdot m_B \cdot f \cdot n \quad \dots \dots \dots \text{(ii)}$$

$$\sigma_p^2 = f^2 \{ \sigma_\mu^2 \cdot n \cdot (n \cdot m_B^2 + \sigma_B^2) + n \cdot m_\mu^2 \cdot \sigma_B^2 \} \dots \dots \text{(iii)}$$

where suffixes P , μ and B are the slip load, slip coefficient and bolt tension, respectively.

Probability p of occurrence of less slip loads than design load P_{a1} , slip generation probability, is obtained as:

$$p = 1 - \frac{1}{\sqrt{2\pi}} \int_t^\infty \exp\left(-\frac{t^2}{2}\right) dt \quad \dots \dots \dots \text{(iv)}$$

where $t = \frac{P_{a1} - m_p}{\sigma_p}$, $P_{a1} = \tau_{a1} \cdot A \cdot f \cdot n$,

τ_{a1} : allowable shearing stress, A : nominal area of bolt shank

In order to calculate p after long duration, (1) the distribution of B is assumed from Fig. 3 to be as follows:

$$m_B = 0.8 \times 1.05B_0, \quad B_0 : \text{minimum required tension}$$

$$\sigma_B = 0.1B_0$$

(2) the slip coefficient μ of surface blasted joints is assumed to be $N(0.88, 0.088)$ from test series D in Table 3, while μ of surface coated joints to be $N(0.60, 0.048)$ from the past test results [5].

When design load P_{a1} was adopted from AISC specification, the value p was calculated as 1.3×10^{-5} ($n=100$) for surface blasted joints, thereby indicating that the risk of joint slip is virtually nil. Whereas, for surface coated joints, $p = 4 \times 10^{-2}$ was obtained, thus indicating that joint slip is liable to occur.

The probability p_0 of slip occurrence for surface coated joints, comes to be 1.3×10^{-3} , when the effect of relaxation of bolt tension is ignored.

Therefore, it will be considered that τ_{a1} is better to reduce 10% or more of the currently used value in AISC ($\tau_{a1} = 203.0$ MPa for inorganic zinc rich painted joint using ASTM A325 bolts) by inverse operation of eq. (iv), if the design condition $p = p_0$ is adopted.

Consequently, although surface coating of structural members is indispensable for the maintenance of steel structures, the allowable shearing stress of the bolts should be reduced below the currently employed values in order to ensure safety of the joints.



REFERENCES

1. FISHER J.W. and STRUIK H.A., Guide to Design Criteria for Bolted and Riveted Joints. Chapter 4 and 5, John Wiley & Sons, 1974
2. FRINCKE M.H., Turn-of-Nut Method for Tensioning Bolts. Civil Engineering, Vol. 28, No. 1, 1958
3. FISHER J.W. et al, Field Installation of High-Strength Bolts in North America and Japan. IABSE PERIODICA, No. 1, February 1979
4. Society of Steel Construction of Japan, Delayed Fracture of High Strength Bolts - Final Report of Exposed Weathering Test -. JSSC, Vol. 15, No. 158, 1979 (in Japanese)
5. As shown in Ref. 1, Chapter 12

Fatigue Tests on Couplings of Tendons under Service Conditions

Essais de fatigue des armatures précontraintes couplées, dans des conditions de service

Dauerschwellversuche an Koppelankern unter praxisähnlichen Bedingungen

Karl KORDINA

o.Prof. Dr.-Ing.
Technical University
Braunschweig, FRG

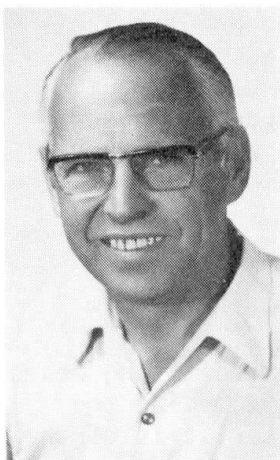

Karl Kordina, born 1919, got his civil engineering degree at the Technical University of Vienna. Since 1959 he is full professor for reinforced concrete structures at the Techn. Univ. of Braunschweig, and director of the Institute for building materials, concrete structures and fire protection.

Ulrich QUAST

Prof. Dr.-Ing.
Technical University
Braunschweig, FRG



Ulrich Quast, born 1937, got his civil engineering degree at the Technical University of Braunschweig. Since 1977 he is professor in the Institute for building materials, concrete structures and fire protection. Before he was a Consulting Engineer in Hamburg.

SUMMARY

Cracks in the construction joints of post-tensioned roadway bridges initiated tests to find out, whether the fatigue strength of the couplings is reduced by being embedded in concrete. In fatigue tests on 14 post-tensioned beams the couplings at the construction joint in mid-span did not behave significantly worse compared with the fatigue loading in 2 million load cycles as applied on acceptance tests with straight bare tendons with couplings.

RESUME

Les fissures dans les joints de construction des ponts-routes précontraints ont conduit à examiner si la résistance à la fatigue des couplages noyés dans le béton était réduite. Des essais de fatigue furent réalisés sur 14 poutres précontraintes avec des couplages au joint de construction, au milieu de la portée. La résistance à la fatigue des couplages ne semblent pas être plus mauvaises que celle des armatures de précontrainte.

ZUSAMMENFASSUNG

Risse an Koppelfugen vorgespannter Strassenbrücken gaben Anlass zu untersuchen, ob die Ermüdungsfestigkeit von Koppelkonstruktionen durch den einbetonierten Zustand nachteilig beeinflusst wird. Dauerschwingversuche an 14 Spannbeton-Biegebalken mit Koppelankern an der Arbeitsfuge in Balkenmitte ergaben gegenüber den in Zulassungsversuchen an freiliegenden Koppelkonstruktionen nach 2 Millionen Lastwechseln nachgewiesenen Schwingbreiten kein signifikant schlechteres Verhalten.



1 INTRODUCTION

In the Federal Republic of Germany multi-span prestressed concrete roadway bridges are often built span by span and concreted in-situ. The construction joint is chosen near the point of zero moment for dead load. All tendons are often anchored at the construction joint for post-tensioning and then coupled for continuation into the next span. As the construction joints remain under service loads theoretically completely in compression there were often only light reinforcements crossing the construction joint. Many bridges are cracked along the joints. This happened especially in hollow-box beams and in the bottom slabs [1,2,3]. The uncracked state as assumed for design does no more exist.

As it is known, the stresses in the reinforcement are increasing with growing cracks. Thus the safety against withstanding the fatigue loading decreases considerably. With the acceptance test for the official authorization of the prestressing system, the admissible fatigue stress is only tested on unembedded tendons. It is well-known that the fatigue strength of embedded reinforcing steel may obviously be smaller than without embedding [4,5]. Regarding prestressing steel fretting corrosion may occur especially when using smooth bars or additional bending of the couplings may reduce the fatigue strength [6,7]. Sufficient results on the behaviour of embedded tendons were so far not available. Therefore it was necessary to realize fatigue tests on coupled tendons under service conditions.

2 TESTS ON EMBEDDED COUPLED TENDONS

2.1 Test Beams

Until now, tests on three typical prestressing systems are executed, using beams as shown by Fig.1 and reinforced as shown by Fig.3. The data concerning the tested prestressing systems are presented in Fig.2. The characteristics of the different couplings are:

- prestressing system DYWIDAG with a short coupling by means of a screwed sleeve,
- prestressing system POLENSKY + ZÖLLNER with a long coupling by means of a stiff coupling bar with thread and
- prestressing system PHILIPP HOLZMANN with a a so-called clamping package.

Tests on the prestressing system LOSINGER/SUSPA, with a coupling by means of a so-called coupling box, have started.

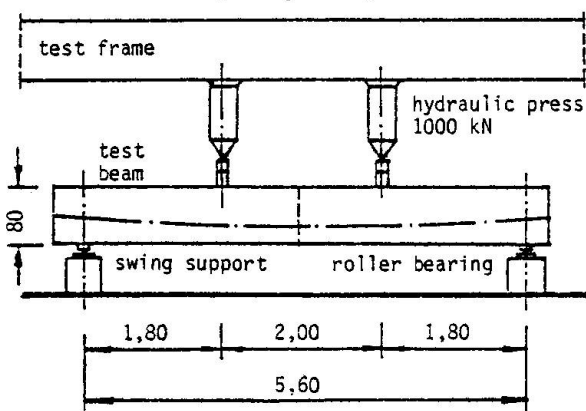

Fig.1 Test set-up

made expect a failure before 1,000,000 only 40 cycles/minute were executable. report [8] and in [9].

For all prestressing systems, a total prestressing force of 1000 kN was aspired. This led to two tendons for each test beam with the prestressing system DYWIDAG and PHILIPP HOLZMANN. The test beams were concreted in two steps. Diverging from normal construction, the prestressing of each half was executed for simplification from the ends of the beams and not from the internal anchorings at the construction joints. The first test serie which is reported here includes 14 beams. The only varied parameter was the range of the pulsating stress $\Delta\sigma$. The high $\Delta\sigma$ -values, which were chosen intentionally, because Detailed results are published in the

Dyckerhoff & Widmann

Smooth bar \varnothing 32 mm
St 835/1030

$A = 8,04 \text{ cm}^2$
adm $F = 455 \text{ kN}$
adm $\sigma = 567 \text{ MPa}$
adm $\Delta\sigma = 68 \text{ MPa}$

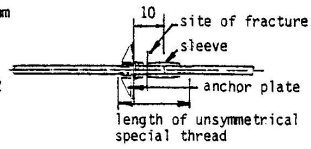

Polensky & Zöllner

bundle with 33 flat
ribbed wires
St 1420/1570

tot $A = 13,2 \text{ cm}^2$
adm $F = 1140 \text{ kN}$
adm $\sigma = 864 \text{ MPa}$
adm $\Delta\sigma = 54 \text{ MPa}$

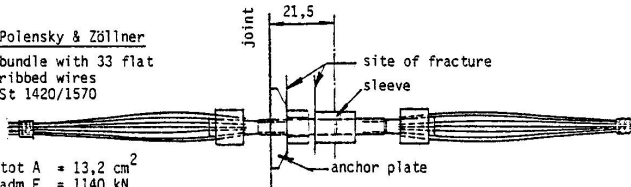

Philipp Holzmann

bundle with 16 flat
ribbed wires
St 1420/1570

tot $A = 6,4 \text{ cm}^2$
adm $F = 552 \text{ kN}$
adm $\sigma = 864 \text{ MPa}$
adm $\Delta\sigma = 68 \text{ MPa}$

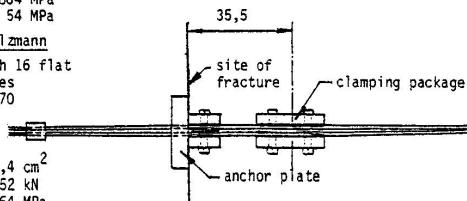

Fig.2 Characteristics of the tendons and their couplings

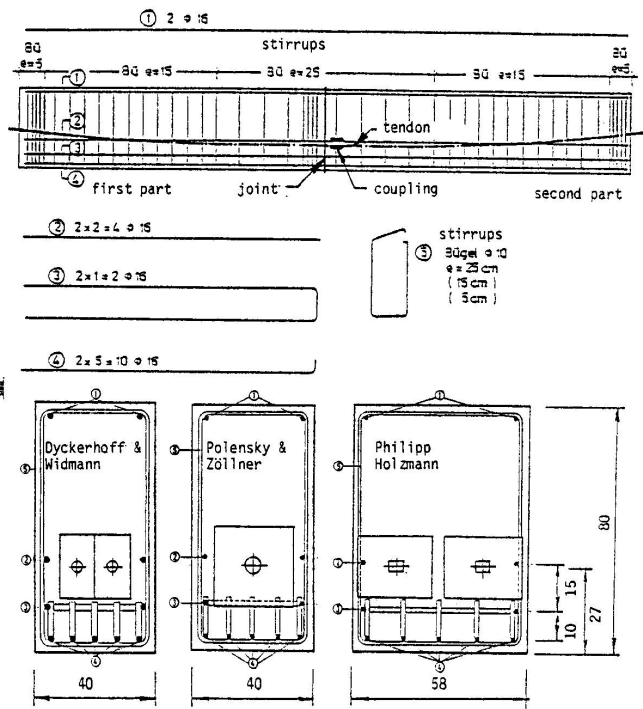

Fig.3 Reinforcement of the test beams and cross-sections



With further planned test series the behaviour under low $\Delta\sigma$ -values will be investigated. Further on the prestressing in both parts of the beams will be chosen of different value, as this often occurs in reality. According to the regulations for edge distances, the widths of the beams were $b = 40$ cm with the prestressing system DYWIDAG and POLENSKY + ZÖLLNER and $b = 48$ cm with the system PHILIPP HOLZMANN. The height of the beams was uniformly chosen as $h = 80$ cm. The total length of the test beams was 6.30 m and the span 5.60 m. The loading acted approximately in the third points, except with beam no.11, where it acted in mid-span. The tendons were placed centrally at the end of the beams and with an eccentricity of $h/6$ in mid-span.

The beams were concreted on two successive days, the part with the coupling at last. A smooth casing was used for the joint, as it corresponds to usual execution. The concrete strength was B 45, corresponding to a cylinder strength of $\beta = 38$ MPa. The injection of the tendons was generally executed directly after the prestressing.

2.2 Measuring Device

Generally about 50 electrical-resistance strain gauges were arranged per tendon. Some of the wire strain gauges were installed directly on the coupling. For interpretation of these test data, the couplings equipped with strain gauges were first of all subjected to calibration tests. Besides of strain measurements on the prestressing steel, also concrete deformations in the compression zone were taken. The opening width of the joint was measured by means of electric-inductance gauges at the height of the tendon axis.

2.3 Test Procedure

The range of the pulsating stress $\Delta\sigma = \max \sigma - \min \sigma$ was chosen in such a way that the beam remained cracked with the minimum stress $\min \sigma$ and the maximum stress $\max \sigma$ was approximately 1.1 times the allowable prestress $\text{adm } \sigma$. The prestress had to be chosen accordingly. Detailed information is presented in Table 1. The change of stresses, which occurs during the execution of the test, was compensated after 10,000 cycles by altering the applied load accordingly.

3 TEST RESULTS

3.1 Formation of Cracks

Fig.4 shows a typical crack pattern. Exceeding the decompression load, the joint opened immediately because an appreciable tensile strength did not exist.

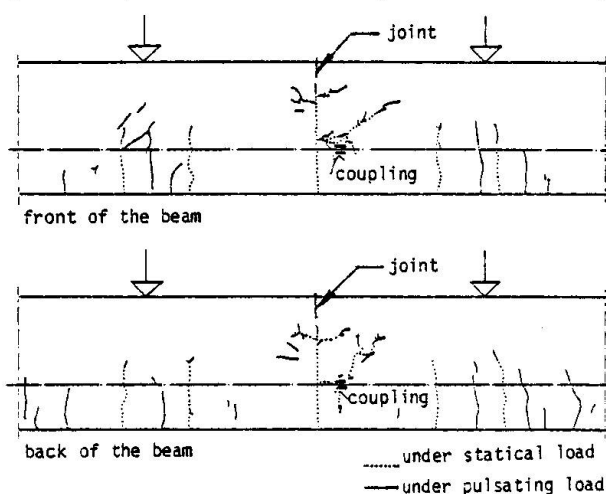

Fig.4 Typical cracks (beam no.10)

When reaching the maximum load, the height of the crack corresponded to the height of the calculated tensile zone. Near the neutral axis horizontal cracks formed, as they are also typical for elements with unbonded tendons. Only in that part of the beam, where the coupling was installed, some diagonal cracks formed near the coupling. Flexural bending cracks starting from the bottom formed at some distance from the joint. During the fatigue loading, some cracks elongated and new cracks were initiated. The change of the crack width difference ΔW in the joint is presented in Fig.5. It increases at first, then remains constant for a long period and increases once again shortly before failure.



3.2 Stresses

The course of the means of the measured pulsating stresses $\Delta\sigma$ for several points of the tendons is presented in Fig.5. The corresponding steel value at the coupling is growing with increasing load cycles but often does not fully reach the calculated value. The stress difference $\Delta\sigma$ decreases sometimes considerably before the failure. The stress differences $\Delta\sigma$ of the prestressing steel near the couplings remain clearly below the value at the coupling. It is also remarkable, that the values for the second part of the beam, where the coupling is installed, remain always somewhat more below the calculated value. At the beginning of the fatigue loading the stress differences increase clearly, reach their maximum and decrease sometimes before the failure. The increase of the stress values at the beginning has to be attributed to gradual bond destruction. This contributes also to the contraction of the compression zone at the end of the fatigue loading. Thereby the distance of the inner forces increases and this explains the decrease of the stress difference before the failure.

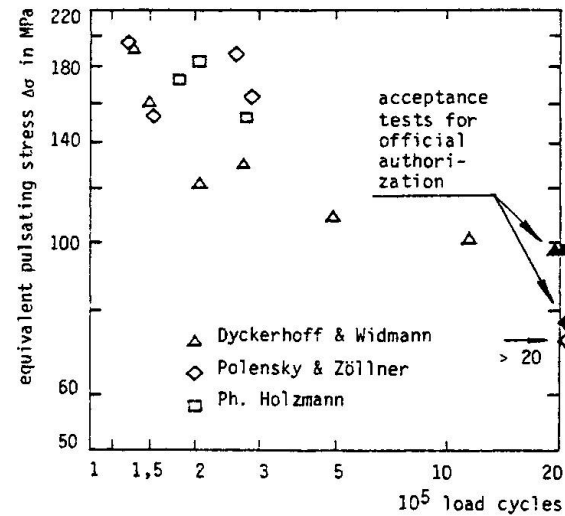
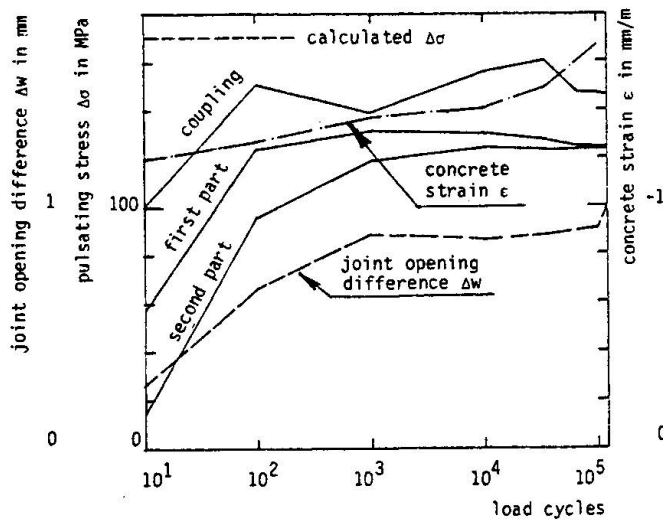

Fig.5 Typical variation of pulsating stress $\Delta\sigma$, joint opening difference Δw and concrete strain ϵ (beam no.5)

Fig.6 Withstanded load cycles as a function of the applied equivalent pulsating stress

prestess. system	DYCKERHOFF + WIDMANN					POLENSKY + ZÖLLNER					PH.HOLZMANN			
	1	2	3	10	11	12	4	5	6	13	14	7	8	9
1 beam no.														
2 prestress	373	390	405	393	426	348	644	654	595	570	365	623	644	651
3 max σ	665	650	675	650	642	666	905	905	930	962	814	955	878	955
4 mean σ	578	574	583	586	559	593	820	820	820	907	736	879	793	854
5 min σ	491	498	491	522	476	520	735	735	710	852	658	803	708	753
6 calc $\Delta\sigma$	174	152	184	128	166	146	170	170	220	110	156	152	170	202
7 meas $\Delta\sigma$	155	134	191	109	116	109	197	150	180	-	170	194	188	175
after 100,000 l.c.														
8 equ $\Delta\sigma$	160	131	192	101	121	109	189	153	195	-	163	152	184	173
9 load cycles / 1000	147	270	133	1139	207	486	254	150	132	2000	287	274	202	178

Table 1 Stresses in MPa and withstanded number of load cycles

Table 1 contains all stress values for the prestressing steel. The stresses given in line 2 were measured during the prestressing procedure and correspond to the stresses under permanent load.



The stresses given in the lines 3 to 6 were determined by computation. The measured stress differences $\Delta\sigma$ were transformed to an equivalent constant value $\text{equ } \Delta\sigma$, given in line 8, according to the hypothesis of Palmgren/Miner and Swanson.

3.3 Fatigue Strength and Fracture Reasons

The withstood number of load cycles for different pulsating stresses $\Delta\sigma$ are presented in Fig.6 in double-logarithmic scale. The withstood stresses for 2 million load cycles from the acceptance tests are also shown for comparison. Tests with embedded tendons do not seem to result in reduced fatigue strength compared with acceptance tests on unembedded tendons. As shown in Fig.2 fractures occurred only within the thread or next to the ribs on the wires at the end of the clamp anchoring, just as this was observed with the acceptance tests.

The fractured planes were investigated metallurgically and fatigue fractures could unambiguously be identified. With the prestressing system PHILIPP HOLZMANN only some of all the 16 oval wires of each tendon showed no signs of fatigue failure. This pertained mainly to the upper wires, which failed due to forced rupture, when a certain part of the wires had already failed due to fatigue.

The reason for the observed relative insensibility of the couplings against additional influences under service conditions in the embedded state might be seen in the fact, that the fatigue strength of the couplings is primarily influenced by notch effects, so that influences due to additional bending or fretting corrosion are only less important.

REFERENCES

1. PFOHL, H., Risse an Koppelfugen von Spannbetonbrücken - Schadensbeobachtungen, mögliche Ursachen, vorläufige Folgerungen. Mitteilungen Institut für Bautechnik, Nr. 6, Dezember 1973, S. 161-165.
2. KORDINA, K. and G. IVANYI, Schäden an Spannbetonbrücken im Bereich von Koppelfugen. Technischer Beitrag zum 8. Internationalen Spannbeton-Kongress, FIP, 1978, S. 1-16.
3. KORDINA, K., Schäden an Koppelfugen. Beton- und Stahlbetonbau, Nr. 4, 1979, S. 95-100.
4. WASCHIEDT, H., Dauerschwingfestigkeit von Betonstählen im einbetonierten Zustand. Deutscher Ausschuß für Stahlbeton, Heft 200, Wilhelm Ernst und Sohn, Berlin, 1968.
5. HARRE, W. und U. NÜRNBERGER, Zum Schwingfestigkeitsverhalten von Betonstählen unter wirklichkeitsnahen Beanspruchungsbedingungen. Schriftenreihe des Otto-Graf-Instituts, Stuttgart, Heft 75, 1980.
6. XERXAVINS, Recherche de la valeur optimum de la tension des armatures de precontrainte. FIP Amsterdam 1955, Session Ib, Pap. 5.
7. WASCHIEDT, H., Ermüdungsfestigkeit von glatten und profilierten Spannstählen mit walzrauer Oberfläche. Beiträge der Friedrich Krupp Hüttenwerke AG, Duisburg-Rheinhausen, zum FIP-Symposium "Spannstähle", Madrid, 1968.
8. KORDINA, K., G. IVANYI und J. GÜNTHER, Dauerschwingversuche an Koppelankern unter praxisähnlichen Bedingungen (Koppelfuge im Zustand II). TU Braunschweig, Institut für Baustoffe, Massivbau und Brandschutz, Forschungsbericht, Dezember 1979.
9. KORDINA, K. and J. GÜNTHER, Dauerschwellversuche an Koppelankern unter praxisähnlichen Bedingungen. Bauingenieur, 1982, S. 103-108.

Financial and Planning Considerations for Bridge Rehabilitation

Aspects financiers et planification de la rénovation de ponts

Finanzielle und planerische Aspekte bei Brückensanierungen

Arunprakash M. SHIROLE

Bridge Engineer
City of Minneapolis
Minneapolis, MN, USA

A.M. Shirole is a registered professional engineer practicing in the State of Minnesota, USA. He holds a Master of Science in Civil Engineering and Masters degree in Business Administration.

James J. HILL

Structural Standards Engineer
Minnesota Dep. of Transp.
St. Paul, MN, USA

J.J. Hill is a registered professional engineer practicing in the State of Minnesota, MN, USA. He holds a Bachelor of Science in Civil Engineering.

SUMMARY

This paper reviews the current use of financial and planning considerations in bridge-rehabilitation decisions. The decision process includes factors such as available manpower and equipment capabilities, planning expertise, and political realities. It presents analytical techniques, such as payoff-matrix, opportunity-loss-table and decision-tree, to systematically incorporate financial and planning considerations for optimal decision making.

RESUME

Cet article considère les aspects financiers et de planification dans les décisions de rénovation de ponts. Le processus de décision comprend des facteurs comme la main d'oeuvre, les équipements disponibles, l'expérience de la planification ainsi que des réalités politiques. Il présente des techniques d'analyse tels que seuils de rentabilité, diagramme avantages-inconvénients et des arbres de décision afin d'incorporer systématiquement les considérations financières et de planification pour une décision optimale.

ZUSAMMENFASSUNG

Dieser Bericht behandelt die üblichen Aspekte für finanzielle und planerische Erwägungen beim Entschcheid von Brückensanierungen. Der Entscheidungsprozess beinhaltet Faktoren wie verfügbare Arbeitskräfte und Ausrüstungsmöglichkeiten, Planungsexpertise sowie politische Gegebenheiten. Er behandelt analytische Techniken wie payoff-matrix, opportunity-loss-table und decision-tree, um finanzielle und planerische Erwägungen beim optimalen Entscheidungsprozess systematisch zu integrieren.



1. INTRODUCTION

It is widely known that many bridges in the United States need to be replaced or rehabilitated and that under the current fiscal constraints, most of these deficient bridges cannot possibly be replaced in the foreseeable future. Therefore, increased emphasis on bridge rehabilitation is inevitable. Although much work has been done in recent years in systematizing analysis, planning and design of bridge replacement; very little attention has been given to similar considerations for bridge rehabilitation. As a result, bridge replacement/rehabilitation decisions are generally being made as a piecemeal synthesis of some, while underestimating or ignoring other relevant considerations. This paper focusses on systematically integrating structure sufficiency, financial and planning considerations into decision-making based upon reliable information, well defined criteria, clearly perceived constraints and uniform evaluation of available alternatives.

2. CONSIDERATIONS FOR BRIDGE REHABILITATION

2.1 Structure Sufficiency Considerations

The first consideration for any bridge rehabilitation/replacement decision-making is whether its structure geometry and load carrying capacity are sufficient to safely carry the present or projected traffic. The necessary information to facilitate determination of structure-sufficiency includes the following:

2.1.1 Structure Inventory and Traffic:

Type, age and geometric details (e.g.: length, width, number of spans, clearances, and alignment) of the bridge and its approaches, material inventory of components; ADT, HCADT and peak-hour traffic and posted load/clearance limits.

2.1.2 Structure Inspection and Appraisal:

Up to date information on condition, its rating, elevation of deterioration, and needed repairs for super and substructure components, professional estimate of structure's remaining life, evaluation of unsafe conditions (e.g.: steep grades, geometric deficiencies, excessive vibrations, etc.); and serviceability considerations such as drainage, rideability and lighting.

2.1.3 Structure Capacity and Functional Adequacy:

Original design and current load carrying capacity, adequacy for present and projected needs, waterway adequacy and protection, if any.

2.1.4 Maintenance Information:

Historical record of maintenance, future maintenance needs, available rehabilitation alternatives with their estimated costs and anticipated improvement in life expectancy.

Based on the above information, the structure is determined to be sufficient or insufficient to safely carry the present or projected traffic. Further, preliminary details of feasible rehabilitation options can be established that will make the structure sufficient for future traffic.

2.2 Financial Considerations

The second consideration, should a bridge need rehabilitation, pertains to available and projected flow of funds. A decision maker needs to consider not only the initial availability of funds for rehabilitation, but also requirements of future flow of funds that the rehabilitation alternate can be expected to create. Like analyses of other highway improvements, total cost basis should underlie rational economic analyses of rehabilitation alternatives. The most commonly used criteria that are useful for comparing total cost of alternate rehabilitation proposals are: present value, annualized costs and prospective rate of return [1,6]. Difficulties arise in application of these criteria while estimating future costs and life expectancies. These difficulties can be overcome by using past experience with similar structures, proficient judgement and probabilistic methods. Statistical techniques can be effectively used to account for element uncertainty in making estimates.

While general revenue funds may sometimes be used for small rehabilitation work, major bridge rehabilitation requires some form of bond or federal and state spending. Conditions and guidelines attached to such funding can effectively restrict feasible rehabilitative alternatives. Prevailing interest rates and availability of local matching funds can make phased rehabilitation a desirable alternative.

2.3 Planning Considerations

Once it has been decided that a bridge needs rehabilitation and financial considerations have established feasible rehabilitation alternatives, planning considerations should be aimed at reaching an acceptable and truly optimal or near optimal decision. Being a major investment decision, to be acceptable, it has to be consistent with the overall agency objectives and policies. Similarly, to be a realistically acceptable alternative, objectives of the rehabilitation proposal should be to make the structure adequate for projected future use. Development plans and projected future needs of the area served, influence functional adequacy of the rehabilitated bridge. These plans can change traffic patterns and influence the type of frequency of traffic at the bridge-crossing. Inadequacy to sustain the projected traffic may eliminate a simple and economical rehabilitation alternative in lieu of a replacement alternate. In addition to adequacy for present and projected traffic, the rehabilitated structure must also meet the minimum requirements of horizontal and vertical clearances, roadway width, waterway opening, if any, and safety.

The bridge rehabilitation work requires innovative approaches as much as, if not more, than a new bridge construction does. Availability of skilled manpower, sometimes of special materials and unique equipment can be very important in the cost effectiveness of a rehabilitation decision. Systematic and expert planning can help overcome real and perceived hurdles in successful rehabilitation. Local and legal constraints can substantially influence the decision making process. In recent years, political realities have increasingly dictated the outcome of what otherwise would have been a very sound decision-making process. As a result, involvement of local groups and consideration of their concerns during the entire decision-making process has become necessary.



Where a major rehabilitation is intended, some state and federal laws may require mandatory compliance with extensive environmental considerations.

A number of cost inputs may be required for planning considerations. These include direct costs for land acquisitions construction easements, project engineering and costs to set up and maintain detours for bridge replacement alternatives. In some cases, inputs may require quantified estimates of economic, special or environmental losses that may result because of different alternatives. Other economic costs that need consideration are costs related to temporary loss of use, traffic delay, accelerated deterioration of structures on detour routes and impact of inflation due to longer duration of construction [7]. Peculiar site conditions, historical significance of the bridge, and technological limitations are some of the other planning considerations. A careful evaluation of these planning considerations can yield a set of acceptable and optimal or nearly optimal rehabilitation alternatives.

3. ANALYTICAL TECHNIQUES FOR EVALUATION

In recent years, increasingly sophisticated methods have become available for analyzing investment decisions. The most widely known of these new developments are the analytical methods that take into account time value of money. A payoff table indicates all alternatives available to the decision-maker, events that can happen, probability distribution of these events, and monetary payoff (+ sign: benefits, - sign: costs) that result from each alternate/event combination. Although it is not easy, it is necessary to convert non-economic consequences into their monetary equivalent before the decision analysis process can continue. A very useful decision criterion for many decision problems under uncertainty is expected monetary value (EMV). In order to compute the EMV for a given alternate, the payoff is simply multiplied by the probability of that event's occurring, and products for each event are added. The expected value of a chance event or random variable X , which can take on any one of n values, is defined to be:

$$\text{- Expected Value of } X = E(X) = \sum_{i=1}^n X_i P(X_i)$$

Where X is the monetary outcome of a decision problem under uncertainty, the expected value of X is usually called Expected Monetary Value, or EMV. The optimal alternative in the payoff table is indicated by the highest EMV.

Another way of analyzing decision problems under uncertainty is to construct an opportunity loss table [6]. The opportunity loss for an alternate/event combination is the difference between payoff for that combination and the best payoff for that event. To construct an opportunity loss table, each event is considered one at a time. All rows of the opportunity loss table are thus completed. The bottom row shows the Expected Opportunity Loss, EOL, for each of the alternates. The EOL is calculated from the opportunity loss table in the same way as EMV is calculated from the payoff table. An alternative which has the lowest expected opportunity loss is the optimal alternative. This optimal alternative will also have the best expected monetary value.

The decision tree approach analyzes a sequence of separate but interrelated events over a time period. The decision tree represents chance events and

alternatives to be chosen at decision points [2, 3, 4]. Proper use of decision trees depends on identifying problem and alternatives, practical time spans and obtaining the necessary data. The preferred alternative is the one which has the greatest net present value (NPV).

4. FLOW CHART OF REHABILITATION DECISION MAKING

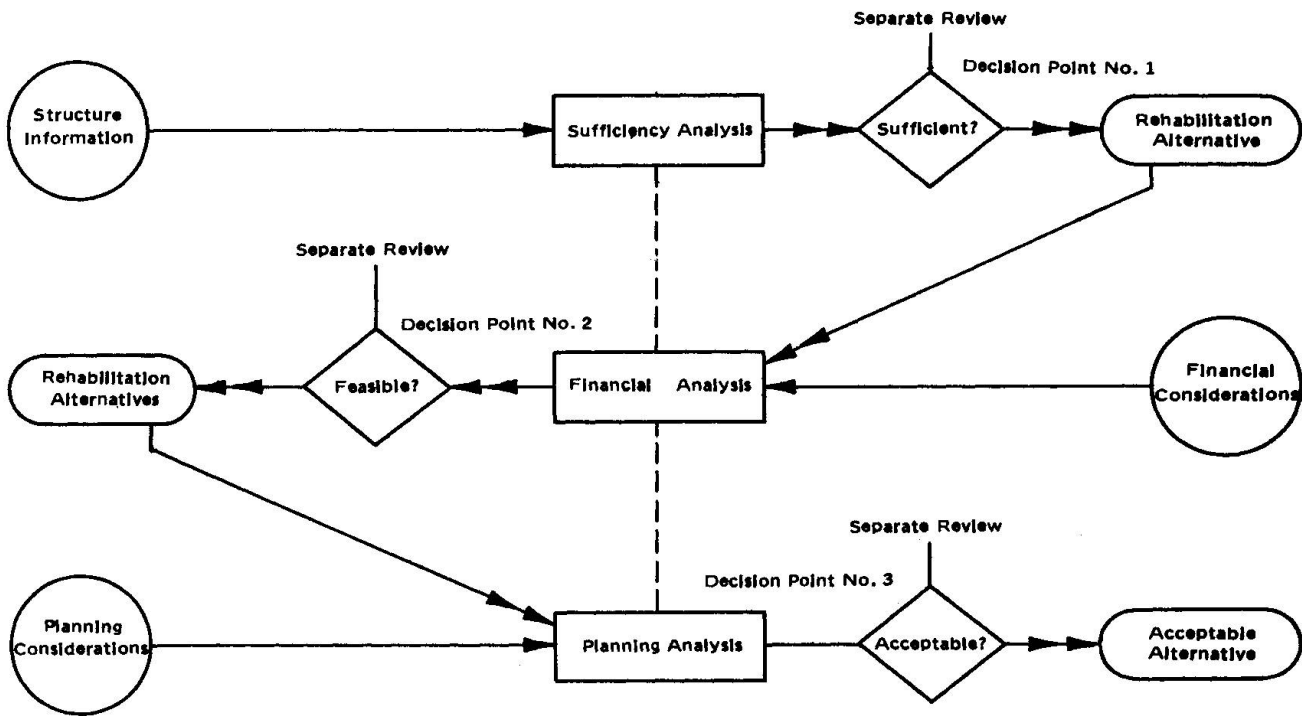

FLOW CHART OF REHABILITATION DECISION MAKING

4.1 A step by step procedure as outlined in this paper is shown in the above flow chart.

5. CONCLUSIONS

This paper has presented a system for bridge structure rehabilitation decision-making. The decision-maker can systematically evaluate a structure on the basis of sufficiency, financial and planning considerations and arrive at a set of acceptable rehabilitation alternatives. This system is simple, adaptive, and the rehabilitation decision process is easy to control.

REFERENCES

1. GRANT EUGENE L. and W. GRANT IRESON. Principles of Engineering Economy. The Ronald Press Company, New York, 1964.
2. HESPOS, R. and P. A. STRASSMON. Stochastic Decision Trees for Analysis of Investment Decisions. Management Science, Vol. 11 #10, August, 1965, pp. B-244 - B-259.
3. MAGEE, JOHN F. Decision Trees for Decision Making. Harvard Business Review, July - August, 1964.
4. MAGEE, JOHN F. How to Use Decision Trees in Capital Investment. Harvard Business Review, September - October, 1964.
5. PLANE, DONALD R., and GARY A. KOCHENBERGER. Operations Research for Managerial Decisions. Richard D. Irwin, Inc. Homewood, Illinois 60403, 1972.
6. SHIROLE, ARUNPRAKASH M., and J. J. HILL. Systems Approach to Bridge Structure Rehabilitation or Replacement Decision-Making, Transportation Research Board Record 664, Bridge Engineering, Vol. I, 1978.
7. American Association of State Highway and Transportation Officials, A Manual on User Benefit Analysis of Highway and Bus-Transit Improvements, 1977.

Designing Bridge Rehabilitations without „Going Under“ (Financially)

Projets économiques de réparation de ponts

Planung von Brückeninstandstellungen „ohne unterzugehen“ (finanziell)

Michael P.E. RAVIV
Structural Engineer
Urbitran, Associates
New York, NY, USA

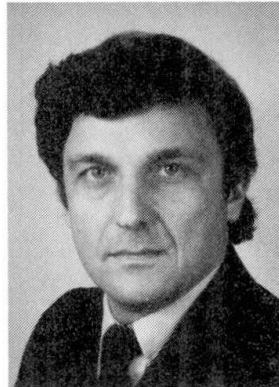

Michael Raviv, born 1947, got his civil engineering degree at the Israeli Institute of Technology. During the last five years he was involved in many small bridge rehabilitation projects in New York and New Jersey. Currently Michael Raviv is Chief Engineer of Urbitran Associates a leading firm in the field of transportation.

SUMMARY

This discussion presents some practical steps and measures to be taken during all phases of small bridge rehabilitation projects with the purpose of avoiding budget overruns. The stages considered are the conception of scope of work, the field inspection, ratings, design and preparation of construction documents.

RESUME

La contribution présente quelques dispositions et mesures à prendre dans toutes les phases de projet de réparation pour des petits ponts, dans le but d'éviter des dépassements de budget. Les étapes considérées sont la conception du travail à entreprendre, l'inspection in-situ, le diagnostic, le projet et la préparation des plans et documents.

ZUSAMMENFASSUNG

Der Beitrag stellt einige praktische Schritte und Massnahmen vor, die in allen Phasen von kleineren Brückeninstandstellungs-Projekten, mit dem Ziel keine Kostenüberschreitungen im Budget zu erhalten, unternommen werden. Es werden die Stufen des Erfassens des Umfangs der Arbeit, die Bestandaufnahme in situ, die Beurteilung und die Vorbereitung der Planunterlagen behandelt.



There is a sequence of steps one takes when undertaking a bridge rehabilitation project: An initial visit to the site, preparation of proposal/scope, in depth field inspection, report, preliminary design, final design, and finally, specifications and preparation of construction documents. In many design firms, where there is a certain specialization of the personnel, all above stages of work are assigned to different persons. In general, the first client contact and preparation of proposals is done by senior members of the firm, the field inspection is performed by an experienced field inspection team and the design is done under the supervision of a design project engineer. Many times, specifications and quantities are prepared by a specification writer. While this approach proves efficient in dealing with large projects, it can result in some overdoing and eventually to financial overruns when applied to small, tight schedule and modestly budgeted projects. A somewhat different approach to this type of project is highlighted in the following discussion:

The central figure in the performance of a small rehabilitation project is the Project Manager who in addition to being a talented engineer has to be well aware of the financial end of running a project. He has to be in constant alert toward the quality of the job while keeping a watchful eye on the dwindling budget assigned to the project. This Project Manager has to handle the project from the initial phase including the fee proposal through the inspection and the design, until the delivery of the final documents on time and within budget. The following are central points one should consider in order to successfully undertake a bridge rehabilitation project.

1. THE INITIAL PHASE

(Client contact, scope, proposal.)

Many times a project will fail because of poor preparation of this first stage. The focal point in the initial stage is to understand the client's needs and his perception of the project. It is reasonable to assume that the client has a long time familiarity with the bridge to be rehabilitated, and that he has his own ideas about possible outcomes and solutions to the problems. During this phase the engineer has to understand its client expectations. It will be advisable to obtain copies of similar completed projects in order to estimate the client's need for details, clarity or use of materials and resources. The client's



standard specifications used in it's projects are another must for establishing the amount of work needed. The proposal, as part of a contract, is an agreement between the parts regarding the amount of work needed to accomplish the project. Extra work claims may easily be documented when based on a detailed proposal. The proposal has to cover following items:

- Detailed description of tasks with projected, manhours
- Duration of the inspection period including cost of subcontractors, equipment, cars, insurances and size of inspection team
- Detailed list of drawings with projected manhours
- Anticipated deadlines and assumption of review periods
- Any other mutual understanding regarding the scope of rehabilitation

This type of detailed scope of work will be easily turned into an extra work claim if, for example, the rehabilitation is more comprehensive than anticipated or when additional work is needed. While the engineer is allways eager to start a new project he should be well aware of the consequences of a poorly prepared proposal. He should allways strive to prepare a detailed well documented proposal

2. THE ORGANIZATION PHASE

It often happens that a team is assigned to start work on a project project on the official start-up date making it almost impossible for the project manager to really manage the job. In order to make use of his personnel, he will assign duties that may not be very important but will keep his people busy. He will continuously leap from person to person and from task to task, thus instead of him managing the project the project is managing him.

The right approach will be for the Project Manager to prepare the job in advance. He will obtain all existing drawings and records, he will visit the site for ascertaining access to all areas, he will line up subcontractors to set up scaffolding or to remove certain members or encasements, he will organize rental equipement such as cars, trucks, snoopers, generators and he will obtain insurances and permits. It is very embarrassing to show up at the site with the inspection team and the equipment to discover that a special entry permit to the Railroad property under the bridge is required. The financial loss of such a day is devastating. Since the costs of equipment are generally higher than the manhour costs, it is important to instruct in advance the members of the inspection team regarding their tasks. During this organization stage, the project manager will prepare a form of progress report which will indicate on a weekly basis the percent of completion versus the budget spent as well as projections for future progress and expenditures. A project well organized during this phase will definitely be performed on time and within budget.



3. THE PROJECT EXECUTION PHASE.

This stage covers the field inspection, the report, the rating and the design with respective intermediate approvals by the client. All these apparent separate tasks are strongly interlocked and interdependent. During this stage the individual talent of the Project Manager will bring the project to a successful completion or will plunge it into an unsurmountable tangle of details and clutter. The following is a nutshell description of short cuts and advise to the project manager of the small bridge rehabilitation project:

- Preliminary rating of typical members should be prepared prior to inspection; it may reveal that new bridge capacity requires stringers or floorbeams be replaced disregarding their physical condition. This may save considerable inspection time when observed in advance.
- Obsolete bearings or joints shouldn't be inspected, measured and evaluated when their replacement was decided in advance.
- A great part of the report can be recorded on tape in the field in the same order it will appear in the final report thus overcoming the "writer's block" that occurs while sitting in front of a bunch of photographs and notes.
- It is good to use the draftsmen in the inspection team and let them prepare good sketches to be transformed into drawings. For example, spalled areas on abutments and concrete piers.
- Deficiencies should be evaluated during inspection and a method of repair established. It makes sense to assign location of possible new members during the inspection thus avoiding a new site trip during the design phase.
- Evaluation of the accurate overlay thickness prior to commencement of calculations is very important in order to avoid recomputing.
- The inspection team is generally reluctant to do some physical tasks. It is better to hire contractors to install scaffolding, to move platforms, to remove concrete encasement or to drill cores.
- Not always can savings be obtained by operating machinery like snoopers or bucket trucks by the inspection staff. Many times this equipment becomes incapacitated and the lack of a trained operator can delay the whole inspection team.
- New details shouldn't be developed when the client is successfully using his own standards. It will be unproductive and time consuming.



- Incorporation of standard sheets should be encouraged as much as possible.
- One should concentrate on eliminating unnecessary details and over detailing. Each one has to be drafted, checked, reviewed and corrected.
- The Project Manager should study the typical contract documents. If a contractor has to supply shop drawings there isn't need for duplication. Many times the contractor can prepare it's own concrete reinforcing bar lists thus saving an enormous amounts of work from the engineer.
- The use of computers in a small project may turn into a continuous money drain and into a time killer, especially when using outside computer services. There are still engineers who can do moment distributions and influence lines by hand.
- Creation of new specifications should be avoided. The client has probably developed all that are necessary and they should be used. Any new ones have to be carefully tailored by the existing ones so as to obtain fast approval
- When dealing with a large bureaucratic client the format of the submission is of great importance samples should be obtained well in advance and followed to the letter.
- The Project Manager should refer to the original proposal handy and refer to it any time a request appears to be outside the original scope of work.

During the duration of the assignment, the Project Engineer will keep close control of the progress and the budget spent. When the project stops temporarily pending some approval, the project team should be assigned to other jobs so to avoid some feet dragging or slowed down production. It will be advisable to monitor the financial expenditures by assigning subcodes to the different tasks and by studying the breakdown of expenses at the end of the job. While this may increase the bookkeeping effort, it will furnish the engineer with some information to be used on future jobs.

In spite of all, no two projects are alike and no two project teams operate the same way. Eventually we will all learn from our mistakes and hopefully we won't pay too much for the learning.

Leere Seite
Blank page
Page vide