

# Collapse of the Viennese Reichsbrücke: causes and lessons

Autor(en): **Reiffenstuhl, Hans**

Objektyp: **Article**

Zeitschrift: **IABSE reports = Rapports AIPC = IVBH Berichte**

Band (Jahr): **39 (1982)**

PDF erstellt am: **25.09.2024**

Persistenter Link: <https://doi.org/10.5169/seals-30168>

## **Nutzungsbedingungen**

Die ETH-Bibliothek ist Anbieterin der digitalisierten Zeitschriften. Sie besitzt keine Urheberrechte an den Inhalten der Zeitschriften. Die Rechte liegen in der Regel bei den Herausgebern.

Die auf der Plattform e-periodica veröffentlichten Dokumente stehen für nicht-kommerzielle Zwecke in Lehre und Forschung sowie für die private Nutzung frei zur Verfügung. Einzelne Dateien oder Ausdrucke aus diesem Angebot können zusammen mit diesen Nutzungsbedingungen und den korrekten Herkunftsbezeichnungen weitergegeben werden.

Das Veröffentlichen von Bildern in Print- und Online-Publikationen ist nur mit vorheriger Genehmigung der Rechteinhaber erlaubt. Die systematische Speicherung von Teilen des elektronischen Angebots auf anderen Servern bedarf ebenfalls des schriftlichen Einverständnisses der Rechteinhaber.

## **Haftungsausschluss**

Alle Angaben erfolgen ohne Gewähr für Vollständigkeit oder Richtigkeit. Es wird keine Haftung übernommen für Schäden durch die Verwendung von Informationen aus diesem Online-Angebot oder durch das Fehlen von Informationen. Dies gilt auch für Inhalte Dritter, die über dieses Angebot zugänglich sind.

## **Collapse of the Viennese Reichsbrücke: Causes and Lessons**

Effondrement du pont Reichsbrücke à Vienne: causes et leçons

Einsturz der Wiener Reichsbrücke: Ursachen und Lehren daraus

### **Hans REIFFENSTUHL**

Prof. Dr. techn.  
Technical University  
Vienna, Austria



Hans Reiffenstuhl, born 1926, study of civil engineering in Graz 1945–1950. Five years' experience in design and execution of structures with an Austrian contractor. 1954 promotion, to Dr. techn. Two years research in the U.S.A. 13 years with an Austrian contractor. Since 1970 professor for reinforced concrete at the TU Vienna and consultant engineer.

### **SUMMARY**

The paper describes in a simplified manner the essential peculiarities of the Viennese Reichsbrücke which led to increasing local splitting forces in the piers for decades. Supervening temperature stresses at the critical location in an unloaded state finally produced the collapse of the whole bridge.

### **RESUME**

L'article résume les caractéristiques principales du pont Reichsbrücke à Vienne, lesquelles ont conduit – au cours des décennies – à une accumulation de tensions d'éclatement dans les piles. Les contraintes thermiques, en augmentation aux endroits critiques, ont finalement causé l'effondrement total du pont, et ceci en l'absence de charges de trafic.

### **ZUSAMMENFASSUNG**

Der Aufsatz schildert in vereinfachter Form die wesentlichen Besonderheiten der Wiener Reichsbrücke, die örtlich zu jahrzehntelang zunehmenden Spaltzugkräften in den Pfeilern geführt haben. Den Einsturz der gesamten Brücke im unbelasteten Zustand lösten schliesslich an der kritischen Stelle hinzukommende Temperaturspannungen aus.



## 1. SPECIAL FEATURES OF THE STRUCTURE

Sunday, August 1<sup>st</sup>, 1976, a quarter to five a.m. the suspension bridge covering 10 000 m<sup>2</sup> collapsed practically without live load - only two automobiles were on the bridge - and claimed the loss of one human life. It seemed that the collapse originated from the failure of a river pier. In figure 1, the cross section through the bridge and the concerned river pier, this fact is displayed by omission of the plunged parts of concrete and ashlar.

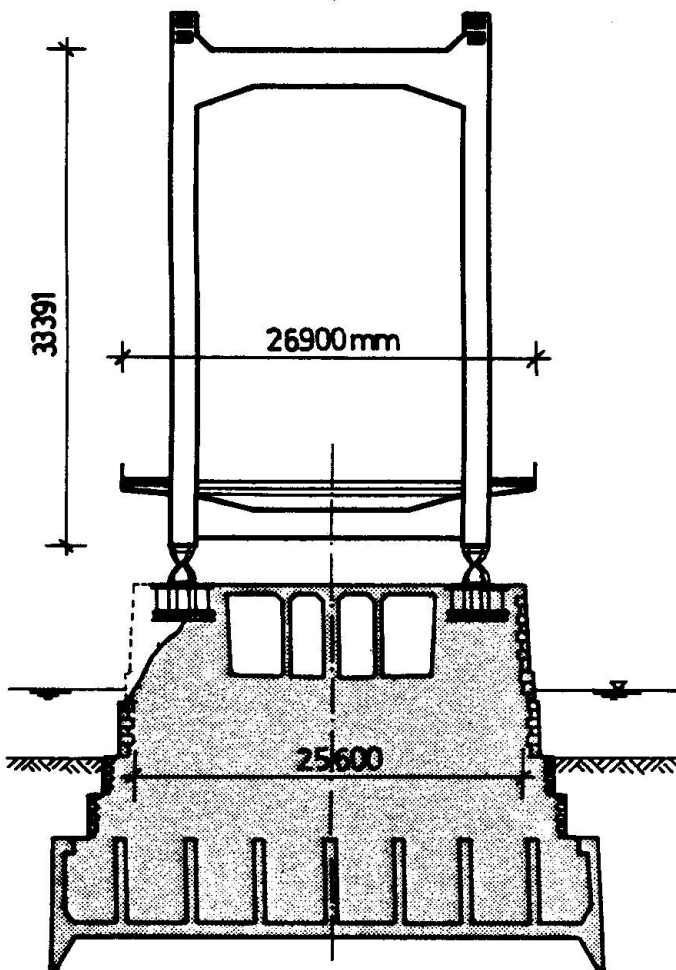

FIG. 1: CROSS SECTION AT PIER XVII a

Yet, before the essential cause of the collapse will be treated, a few peculiarities of the structure and of the pier are to be described, which finally led to the catastrophe (in combination with the influences of creep and temperature).

### 1.1 The statical system (fig. 2)

The iron suspension bridge, built in 1936, was originally planned as a genuine suspension bridge. Only during the erection of the

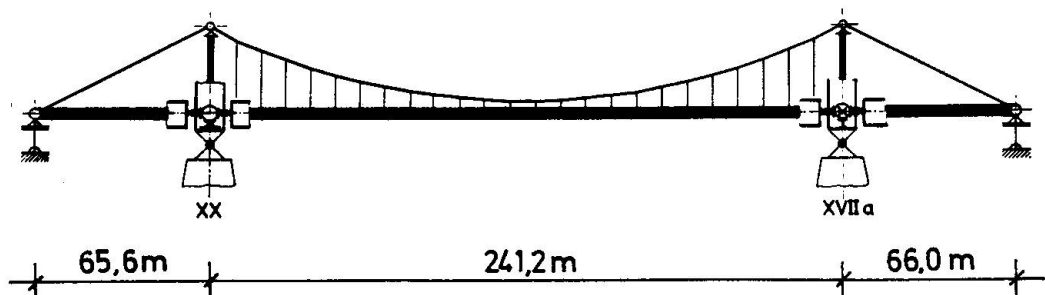

FIG. 2: STATICAL SYSTEM

stiffening girder in the main span the statical system of the bridge was changed to a self anchored suspension bridge due to rather strong differences in the judgement of the soil properties; therefore it was necessary to anchor the horizontal tension of the chains to the suspended stiffening girder and strengthen it correspondingly.

This measure led to an unusual statical system with hinged connections of the stiffening girder at the piers, penetrating the pylons which acted as columns hinged at both ends. For the main loads this system was statically determinate. Failure of one essential member was sure to lead to the collapse of the whole structure.

### 1.2 The bearings under the pylons

Each of the bearings was made of cast steel, designed for a working load of 90 000 kN of which 70 000 kN were dead load. The hinge function in any direction was achieved by the contact of two spherical surfaces with different radius of curvature. In order to distribute the load over an adequate contact area the radii of curvature of both spherical surfaces were only slightly different, that is 6 000 mm and 9 000 mm. Therefore, the bearings were sensitive to inclinations of the pylons responding with relatively great excentricities of the load.

### 1.3 The river piers

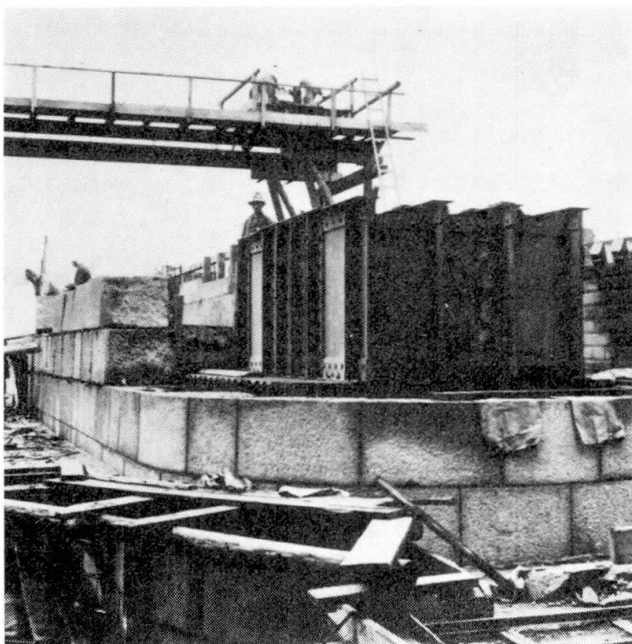

Under each pylon bearing a heavy grid of bolted steel girders of 1,60 m high was concreted into the head of the pier. For better distribution of the load the grid rested upon rolled I-beams layed closely to eachother (Fig.1 to 3). No other reinforcement of the piers was provided. The external dimensions of the pier shaft were just so large that the steel grid and the mat of rolled beams found enough

FIG. 3: PIER XVII<sub>a</sub> DURING ERECTION (1935)



space between the headers of the ashlar.

The unreinforced concrete just under the rolled beams had the relatively high cylinder strength of  $55 \text{ N/mm}^2$ , measured after the disaster. (The maximum pressure under full load below the mat of  $4,5 \text{ N/mm}^2$  was comparatively small). Lower concrete layers showed various cylinder strengthes down to  $24 \text{ N/mm}^2$ . There is no doubt that these relatively high compression strengthes developped only in the course of the 40 years coninuous hardening of the cement paste. Certainly the cement qualities of those days showed the characteristic of longtime hardening to a great extent as everybody knows.

## 2. THE CAUSES OF THE COLLAPSE; SIMPLIFIED ESPECIALLY BY REGARDING THE PIER AS A PLANE SYSTEM

(The complete wording of the commission's expertise is given in [1] ).

### 2.1 Creep of concrete

As subsequent measurements revealed, the stones of the granite ashlar must have been broken from a zone close to the surface of the quarry. They had a modulus of elasticity which for granite was very low indeed. The order of magnitude was about the same as the one of the neighbouring concrete. Therefore, the flow of forces underneath the grid at first corresponded rather well to that one which can be expected in a homogenous material. The dashed line in fig. 4 indicates this behaviour.

Since the granite has no ability to creep in the course of decades redistribution of forces occurred in the pier's head: Because of the unyielding granite a steadily increasing amount of the load flowed from the concrete into the granite ashlar at the front surface of the pier (indicated by the dash-dotted line in fig.4). Some time or other the splitting forces developping at the same time produced an initial crack in the concrete (heavy line in fig. 4) so that the forces due to deflection of the load path charged the squat bar developped at the left side of the initial crack in bending. With increasing redistribution of the load flow the bending stresses of the squat bar and the length of the initial crack became greater and greater.

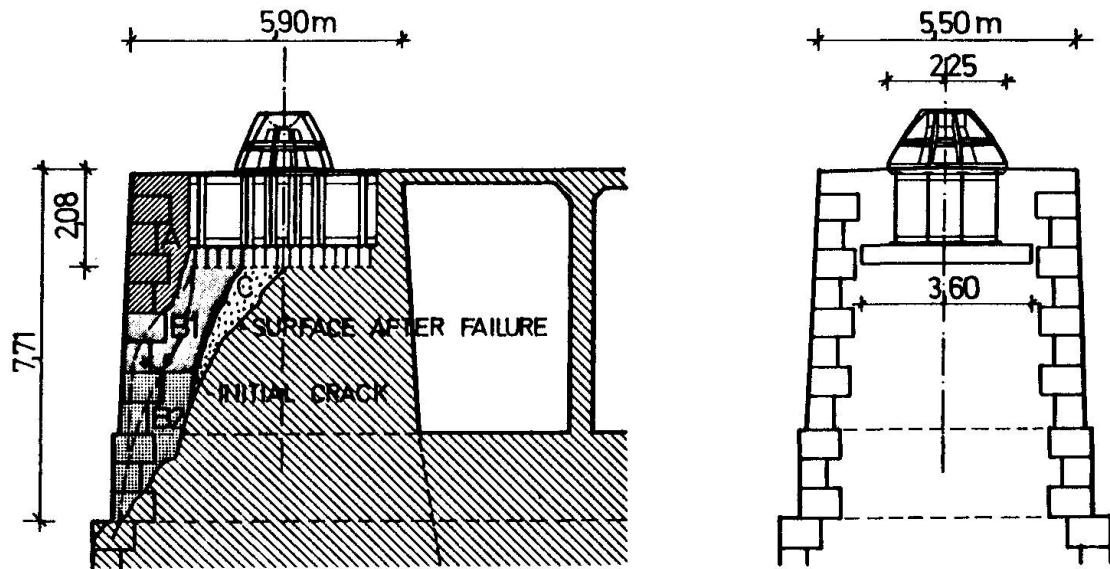

FIG. 4 : PIER XVIIa CRACK FORMATION AT FAILURE  
A, B1, B2 FRACTIONS C CRUSHED PART

## 2.2 Temperature

Until ten days before the collapse Austria had been struck by a longlasting heatwave which had been superseded by unusually cold weather. The slowly penetrating cooling of the pier, still warm in its interior, led to the maximum of tensile stresses in the zones close to the surface after several days. Combined with the bending tensile stresses due to the redistribution of the load flow as a consequence of creep they led to the failure in bending of the squat bar to the left of the initial crack - fortunately in an unloaded state of the bridge. The mechanism can be realized from the parts B1 and B2 (fig. 4) salvaged from the Danube seven months after the disaster.

## 3. SUCCESSION OF FAILURES UNTIL THE TOTAL COLLAPSE

After a portion of the grid's bottom area had become unsupported due to the plunge of the granite and concrete parts the pressure at the edge of the remaining supporting area under the grid crushed the concrete. The whole grid tilted and produced great excentricity of the pylon's load in the spherical contact surfaces of the pylon bearing which bursted immediately and introduced the collapse of the total superstructure. The kinds of damages and the final position of the parts as well as the sequence of the further events are explained and interpreted in the



expertise mentioned before.

#### 4. LESSONS FOR MAINTENANCE OF BRIDGES

4.1 Unreinforced piers with stone ashlar can be endangered by time dependent splitting forces, especially when bearing loads are introduced directly into the concrete or the like between the ashlar.

4.2 Larger structures generally should be investigated from time to time with respect to new scientific findings.

For reasons of completeness it may be noted that the first mathematical treatment of creep was shown by Dischinger in 1937 [2] on arch bridges. He also was the first to calculate the redistribution of loads from concrete to the ashlar in a bridge pier in 1939 [3] .

#### REFERENCES

1. LÖTSCH, K., PAUSER, A., REIFFENSTUHL, H., SATTLER, K. and STEIN, P.: Bericht der Expertenkommission zur Beurteilung der Ursache des Einsturzes der Wiener Reichsbrücke. Der Aufbau, 1977, page 303
2. DISCHINGER, F.: Untersuchungen über die Knicksicherheit, die elastische Verformung und das Kriechen des Betons bei Bogenbrücken. Der Bauingenieur, 1937, page 487 to 621
3. DISCHINGER, F.: Elastische und plastische Verformungen der Eisenbetontragwerke und insbesondere der Bogenbrücken. Der Bauingenieur, 1939, pages 53 to 63, 286 to 294, 426 to 437 and 563 to 572