

**Zeitschrift:** IABSE reports = Rapports AIPC = IVBH Berichte  
**Band:** 60 (1990)

**Artikel:** Research on beams with open steel box reinforcement  
**Autor:** Daalov, Totyu / Petrov, Krastyu  
**DOI:** <https://doi.org/10.5169/seals-46444>

### **Nutzungsbedingungen**

Die ETH-Bibliothek ist die Anbieterin der digitalisierten Zeitschriften auf E-Periodica. Sie besitzt keine Urheberrechte an den Zeitschriften und ist nicht verantwortlich für deren Inhalte. Die Rechte liegen in der Regel bei den Herausgebern beziehungsweise den externen Rechteinhabern. Das Veröffentlichen von Bildern in Print- und Online-Publikationen sowie auf Social Media-Kanälen oder Webseiten ist nur mit vorheriger Genehmigung der Rechteinhaber erlaubt. [Mehr erfahren](#)

### **Conditions d'utilisation**

L'ETH Library est le fournisseur des revues numérisées. Elle ne détient aucun droit d'auteur sur les revues et n'est pas responsable de leur contenu. En règle générale, les droits sont détenus par les éditeurs ou les détenteurs de droits externes. La reproduction d'images dans des publications imprimées ou en ligne ainsi que sur des canaux de médias sociaux ou des sites web n'est autorisée qu'avec l'accord préalable des détenteurs des droits. [En savoir plus](#)

### **Terms of use**

The ETH Library is the provider of the digitised journals. It does not own any copyrights to the journals and is not responsible for their content. The rights usually lie with the publishers or the external rights holders. Publishing images in print and online publications, as well as on social media channels or websites, is only permitted with the prior consent of the rights holders. [Find out more](#)

**Download PDF:** 13.04.2026

**ETH-Bibliothek Zürich, E-Periodica, <https://www.e-periodica.ch>**

## Research on Beams with Open Steel Box Reinforcement

Recherches sur les poutres de béton avec coffrage en tôle d'acier servant d'armature

Experimentelle Untersuchungen von Stahlverbundbalken mit mitwirkender Stahlblechschalung

### Toty DAALOV

Dr. Eng.  
Metalni Konstrukzii  
Sofia, Bulgaria



Toty Daalov, Civil Engineer Dr., senior research associate in the Scientific Laboratory of "Metalni Konstrukzii" Sofia, Bulgaria Born 1941, civil eng. 1966, active in the field of buildings construction, head of section.

### Krastyu PETROV

Civil Eng.  
Metalni Konstrukzii  
Sofia, Bulgaria



Krastyu Petrov, Civil Engineer in the Scientific Laboratory of "Metalni Konstrukzii" Sofia, Bulgaria Born 1958, civil eng. 1981, active in the field of composite structures.

### SUMMARY

Results are reported of experimental and theoretical studies of the load bearing capacity and deformability of five types of open steel box reinforced concrete beams. Some data from a project for the construction of a two-storey office building, based on these results, are given.

### RÉSUMÉ

Le rapport comporte des résultats de recherches expérimentales et théoriques sur la capacité portante et la déformabilité de cinq types de poutres armées par un coffrage en tôle d'acier. Il fournit les données d'un projet de construction d'un bâtiment administratif, dans lequel les résultats de ces recherches ont été appliqués.

### ZUSAMMENFASSUNG

Der Bericht enthält Ergebnisse von experimentellen und theoretischen Untersuchungen über die Tragfähigkeit und Formänderungen von fünf Typen von Stahlverbundbalken mit mitwirkender Stahlblechschalung. Einige Angaben zum Entwurf eines zweigeschössigen Bürohauses, bei dem diese Ergebnisse genutzt wurden, werden dargestellt.



An advantage of the open box steel reinforcement is the possibility to use it also as formwork and falsework (casing) of the fresh concrete mix. After the hardening of the concrete it "works" as reinforcement, giving thus the opportunity to reduce the bar reinforcement and to shorten the time-schedule for execution of the construction (participating permanent form-work).

Five types of model elements (beams) with open steel box reinforcement, used also as casing, have been investigated. Their cross sections are shown on fig. I, all of them having a length of 2000 mm. The open box reinforcement has been made from two cold-formed L shaped steel-sheet profiles with 2 mm thickness. The profiles are connected in their bottom parts every 150 mm by weldings of 50 mm length and their upper parts by plates (4) or dowels (I).

The elements of type A have no shear connectors. The elements of type B and C have as shear connectors dowels (I), made from L-shaped cold-formed steel profiles 20.20.3 mm (fig. 2). They are fixed to the casing by point weldings. The elements of type C have in their bottom part two N: I8 longitudinal reinforcement bars, class S 400 / (3) in fig. I/.

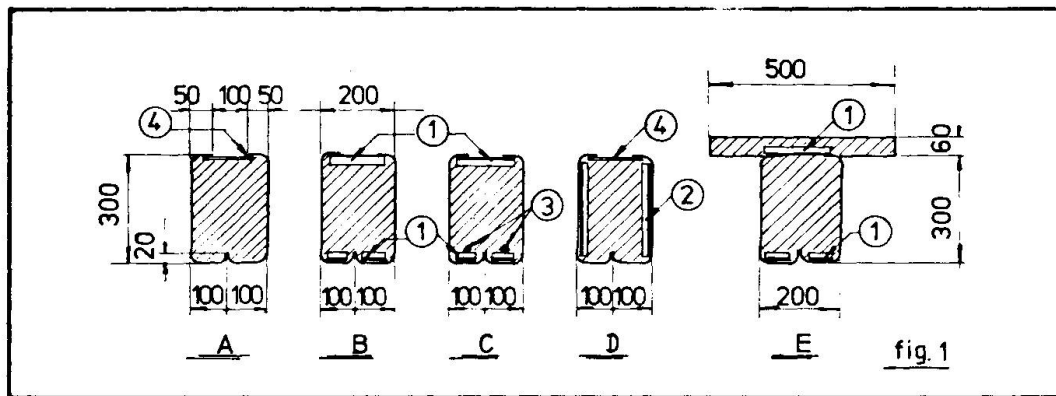

In the elements type D the shear connectors (2) are fixed to the side walls of the casing under an angle of  $45^\circ$ , their cross section being identical with that of dowels (I). The elements of type E are as the elements of type B; but they have a concrete plate of 60 mm thickness.

The yield-point of the casing sheet is  $R_y = 302 \text{ MPa}$  and the modul of elasticity is  $E_s = 2,05 \cdot 10^5 \text{ MPa}$ . The bar reinforcement has an yield-point  $R_y = 428 \text{ MPa}$ , a sbrength  $R_u = 693$

MPa and a modul of elasticity  $E_s = 2 \cdot 10^5$  MPa. The cube strength of the concrete is 24,7 MPa, the cylinder strength - 22,5 MPa, the tensile strength - 2,96 MPa and the modul of elasticity - 21700 MPa.

The aims of the study were:

- to investigate the bearing (resisting) capacity and the deformability of the different types of elements;
- to assess the methods of producing of the casing and of the elements (beams).

The elements have been tested in bending, loaded with two concentrated forces  $P$ , located in equal distances  $\frac{L}{4}$  from the supports by a span  $L = 1900$  mm. The deflections were measured in the middle of the span and at the ends. The strains of the steel casing and of the concrete were registered in the middle of the span with tensorezistor sensors. Their position is shown in fig.2.

The theoretical model for evaluation of the ultimate resisting capacity of the elements and of the resistance action effects during the different stages of loading is based on the following assumptions:

- a). Plane cross sections remain plane (Bernoulli);
- b). Steel sheet and bar reinforcement are subject to the same changes of deformation as the adjacent concrete;

c). The stress-strain diagram of the sheet casing is according to the idealized diagram of Prandtl;

d). The stress - strain diagram of the concrete in the compression zone is as recommended by the Euro - International Committee for Concrete (C.E.B. - F.I.P. Model Code).

For the calculation of the deflections of the elements is

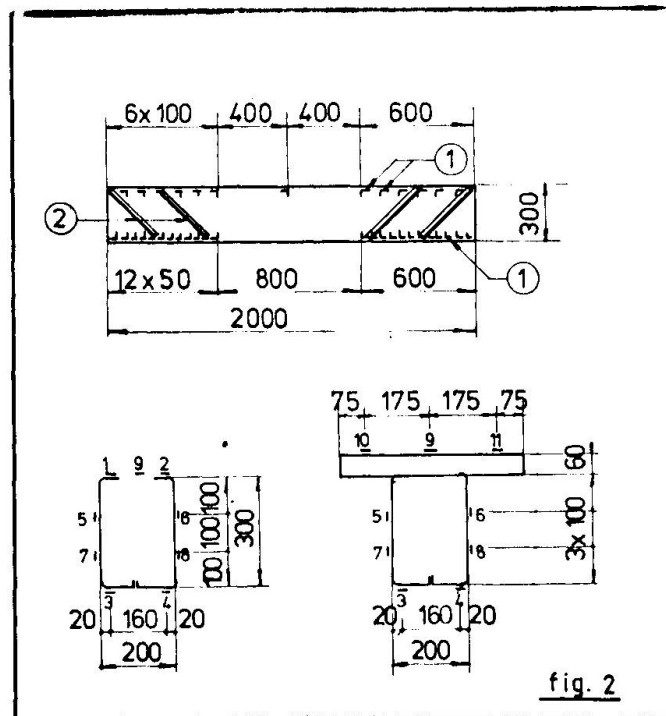

fig. 2



used the formula

$$\frac{I}{\rho} = \frac{E_{34} - E_9}{h}$$

where E stands for the strains in the bottom and in the top of the elements, and h - for the height of the elements.

Computer programmes have been composed for calculating the bending moments and the deflections as functions of the strain of the most compressed concrete part.

A comparison of the theoretically calculated and experimentally registered deflections and strains is given in Table I.

		Theoretical					Experimental					R
B	P KN	39	65	91	117	130	39	65	91	117	130	182
	$\epsilon_{34}$ ‰	0,46	0,78	1,14	1,41	1,58	0,16	0,70	1,05	1,48	1,58	5,89
	$\epsilon_9$ ‰	0,14	0,28	0,47	0,70	0,78	0,18	0,24	0,53	0,70	0,79	4,06
	f mm	0,88	1,58	2,39	3,12	3,49	0,43	1,62	2,40	3,53	4,11	14,26
D	P KN	39	65	91	117	130	39	65	91	117	130	182
	$\epsilon_{34}$ ‰	0,46	0,78	1,14	1,41	1,58	0,17	0,62	1,09	1,52	1,73	10,99
	$\epsilon_9$ ‰	0,14	0,28	0,47	0,70	0,78	0,11	0,28	0,44	0,64	0,75	2,14
	f mm	0,88	1,58	2,39	3,12	3,49	0,42	1,34	2,26	3,25	3,80	14,32
C	P KN	42	84	126	168	210	42	84	126	168	210	252
	$\epsilon_{34}$ ‰	0,45	0,50	0,62	0,90	1,86	0,18	0,51	0,90	1,24	1,56	5,71
	$\epsilon_9$ ‰	0,32	0,42	0,57	0,85	1,50	0,37	0,89	1,31	1,69	2,15	7,06
	f mm	1,14	1,37	1,77	2,60	5,00	0,40	1,50	2,62	3,84	5,48	16,57
E	P KN	42	84	126	168	210	42	84	126	168	210	273
	$\epsilon_{34}$ ‰	0,70	0,80	0,96	1,32	2,50	0,11	0,47	0,88	1,38	2,34	3,48
	$\epsilon_9$ ‰	0,12	0,16	0,23	0,35	0,65	0,13	0,35	0,56	0,79	1,19	2,39
	f mm	1,02	1,19	1,48	2,06	3,89	0,24	0,94	2,15	3,74	6,02	16,04
R - breaking load						Table 1						

The results from the tests with elements of type A are not presented as the differences between the theoretical and experimental data are too large, which is obviously due to lack of bond between the casing and the concrete.

The elements of type A, B, D and E failed due to yielding of the box reinforcement in the tensile zone whilst the elements of type C failed by destruction of the concrete in the compression zone.

The comparison of the strains at different points of the cross sections witnesses that the Bernoulli assumption is valid in these cases. The deviation from it exists only when the strains are extreme.

The deflection of the elements as a function of the load  $P$  are shown in fig. 3. The deflections of the elements type A correspond to a beam with stiffness equal to the stiffness of the casing, which again gives evidence, that the bond of the casing with the concrete without shear connectors is insufficient. In the elastic stage the elements of type D (with diagonal shear connectors) are less deformable when compared with the elements of type B for the relevant steps of loading (fig.3).

The theoretically calculated deflections of the elements type D are nearest

to the experimentally registered deflections.

The conclusions of the study are as follows:

the failure of the elements occurs in the plastic range; the shear connectors provide for a reliable bond of the casing with the concrete; the cross sections remain almost near to the failure; the theoretical model for calculation is a very good approximation to the real behaviour of the elements under loading; allowing for small plastic deformations of the casing in creases the bearing capacity without remarkable reducing of the bond.

The results of the study were used for the project of a two stories office - building. The construction is a skeleton one. The beams and columns are provided with a box reinforcement of 4 mm thickness. The columns with a cross section 400/400 mm are at a distance of 6 m. The slabs are with corrugated sheets and 60 mm thick concrete. The connection of the sheets with the

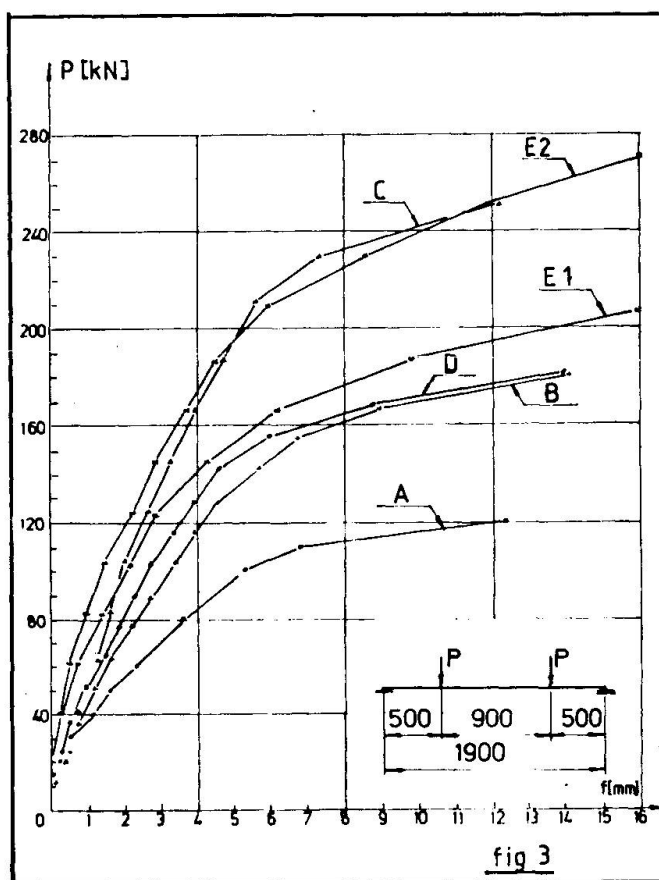



beams is realized by HILTI - bolts (HVB -105). They are also bonding the concrete with the steel. Additional reinforcement bars are placed only in the frame corners of the skeleton and over the supports of the slabs. The horizontal seismic forces of magnitude IX of the MSK scale are taken up by frames.

The amount of materials per  $m^2$  spread out floorage is as follows:

- 0,15  $m^3$  of concrete
- 5 kg of reinforcing bars
- 6,3 kg corrugated sheets
- 34 kg. steel sheet

The time - schedule for execution of the construction is reduced twice.

The application of open box steel reinforcement is Technologically advantageous as it substantially reduces the amount of formwork, falsework and reinforcement work.