

Shell girders in structural engineering (Poland)

Autor(en): **Augustyn, Jan**

Objekttyp: **Article**

Zeitschrift: **IABSE structures = Constructions AIPC = IVBH Bauwerke**

Band (Jahr): **13 (1989)**

Heft C-50: **Recent structures**

PDF erstellt am: **24.09.2024**

Persistenter Link: <https://doi.org/10.5169/seals-21577>

Nutzungsbedingungen

Die ETH-Bibliothek ist Anbieterin der digitalisierten Zeitschriften. Sie besitzt keine Urheberrechte an den Inhalten der Zeitschriften. Die Rechte liegen in der Regel bei den Herausgebern.

Die auf der Plattform e-periodica veröffentlichten Dokumente stehen für nicht-kommerzielle Zwecke in Lehre und Forschung sowie für die private Nutzung frei zur Verfügung. Einzelne Dateien oder Ausdrucke aus diesem Angebot können zusammen mit diesen Nutzungsbedingungen und den korrekten Herkunftsbezeichnungen weitergegeben werden.

Das Veröffentlichen von Bildern in Print- und Online-Publikationen ist nur mit vorheriger Genehmigung der Rechteinhaber erlaubt. Die systematische Speicherung von Teilen des elektronischen Angebots auf anderen Servern bedarf ebenfalls des schriftlichen Einverständnisses der Rechteinhaber.

Haftungsausschluss

Alle Angaben erfolgen ohne Gewähr für Vollständigkeit oder Richtigkeit. Es wird keine Haftung übernommen für Schäden durch die Verwendung von Informationen aus diesem Online-Angebot oder durch das Fehlen von Informationen. Dies gilt auch für Inhalte Dritter, die über dieses Angebot zugänglich sind.



10. Shell Girders in Structural Engineering (Poland)

Technical characteristics and application range of shell girders

Shell girders i.e. steel plated girders composed of single-curved plates and stiffeners, primarily developed in carriage and aircraft constructions, are lately also being applied in some civil engineering structures, partly replacing box girders.

The application range is determined by the specific advantages of shell girders as compared to box girders, namely:

- higher load carrying capacity of curved plates in compressed zone of cross-section related to the buckling strength and stiffness against local loading,
- more even distribution of tension stresses (torsion) and normal stresses (biaxial bending),
- higher fatigue strength,
- more advantageous form for corrosion protection,
- lower wind pressure and snow-load (for exposed structures),
- and - last but not least - better aesthetics.

On the other hand the application of shell girders is limited by higher labour costs, because of additional operations (bending of plates and shaped bars). This disadvantage is of importance for single executed unit structures and can be minimized in series production.

Generally speaking, the steel consumption of shell girders is less and the labour cost higher as compared to box girders.

As a result, the first ones are being applied presumably in countries, where the relation of material cost to labour cost for product unit is high. Nowadays they are being applied as:

- band conveyor galleries,
- pipeline bridges,
- covered ways for pedestrians,
- highway bridges,
- overhead travelling and gantry cranes.

Most of the structures described below have been designed by J. Szulc, Polish civil engineer and pioneer of the development of shell beams in civil engineering constructions (died 1988). All photos were made by A. Borkowska, Warsaw.

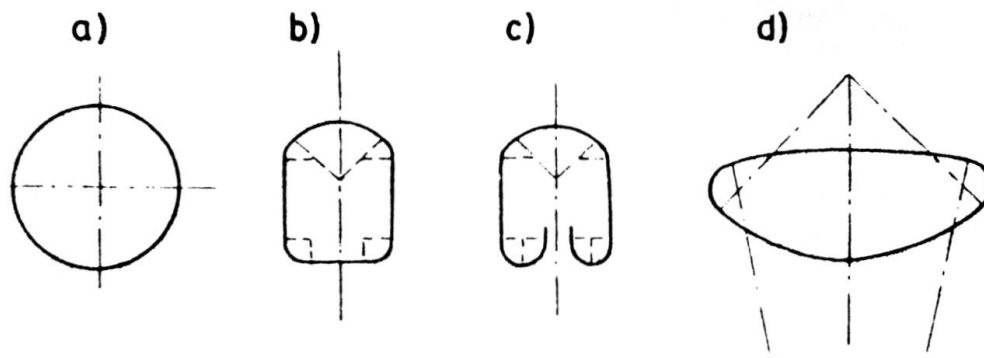

Fig. 1 Typical contour shapes of shell beams

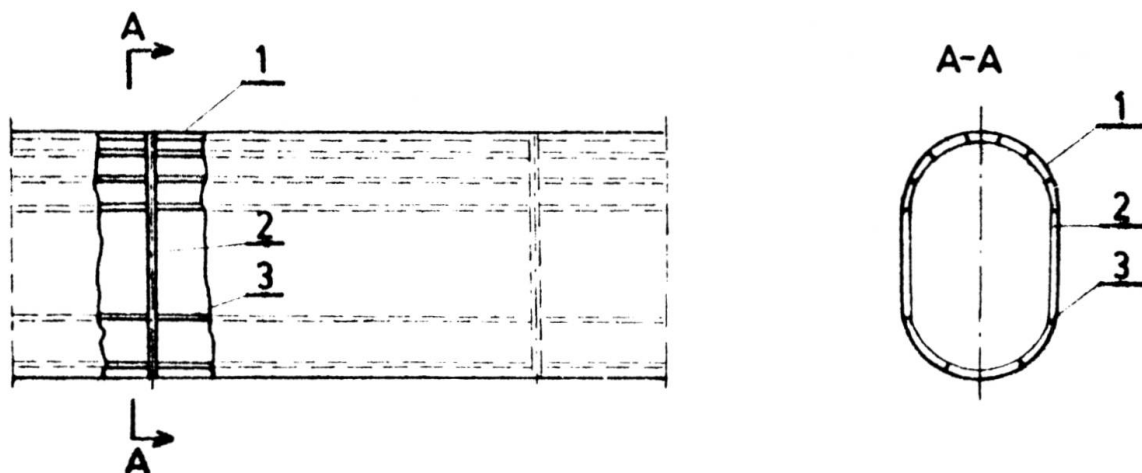

Fig. 2 Components of shell beam segment

Design principles

Typical contour-shapes of shell beams applied in structural engineering are shown on Fig. 1.:

- cylindrical – for pipeline bridges and overhead travelling cranes,
- oval – for band conveyor galleries as well as for pipeline bridges and covered ways,
- oval – for highway bridges,
- concave-convex oval – for gantry cranes.

Each oval shape is composed of some cylinder segments. In a tension zone as well as in the area close to the neutral axis flat segments of covering are being applied.

Independent on contour-shape each shell beam consists of (Fig. 2):

- 1 shall (covering),
- 2 steel ribs (circumferential),
- 3 steel stiffeners (longitudinal).

The ribs and stiffeners form a panel structure shown on Fig. 2. The support ribs are usually stronger than the other ones.

For determining the internal forces (bending moment M , shear force V , longitudinal force N) in a cross-section of a shell girder, the formulae of elementary statics of simply supported or continuous beams are being applied. However, the determination of the stress distribution in particular structural components (shell, ribs and stiffeners) is much more complicated and in the general case an exact solution is not available. Thus the calculation methods developed for aviation structures have often been used with some simplifications (e.g. 4-chord model with substitutional web). Nowadays the finite element method is often being applied, especially, if a concentrated load is taken into consideration.

After determining of stress distribution, the shell thickness and dimensions of ribs and stiffeners are being selected in one of two ways:

- according to the elasticity theory formulae (Huber-Mises criterion for interaction of normal and shear stresses compared to the yield strength in tension zone and elastic buckling strength in compression zone),

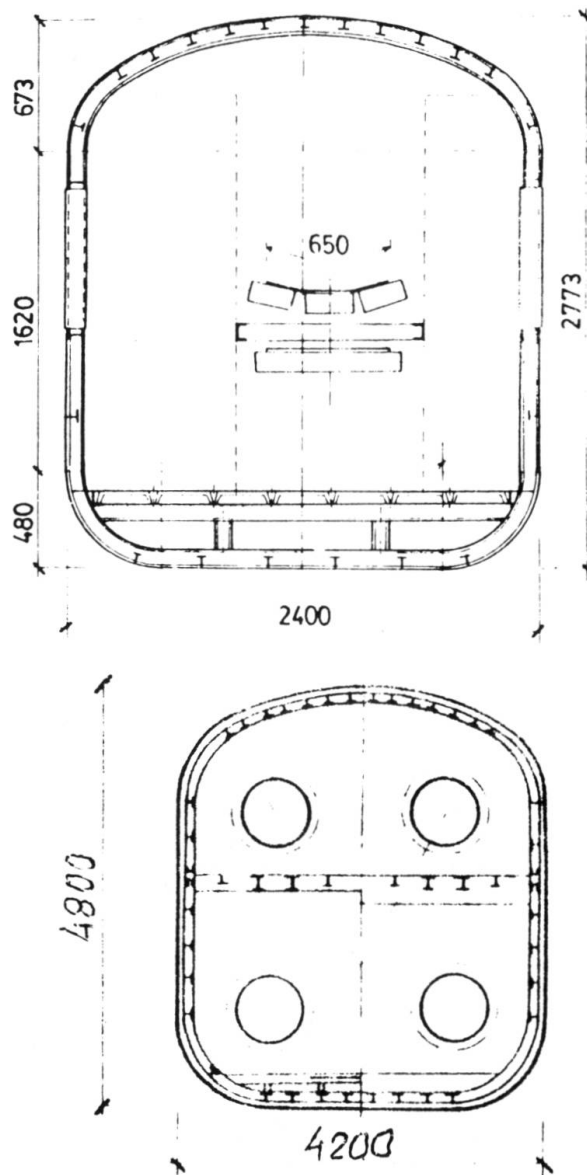

Fig. 4 Cross-section of shell beams for:
a) conveyor gallery, b) pipeline bridge

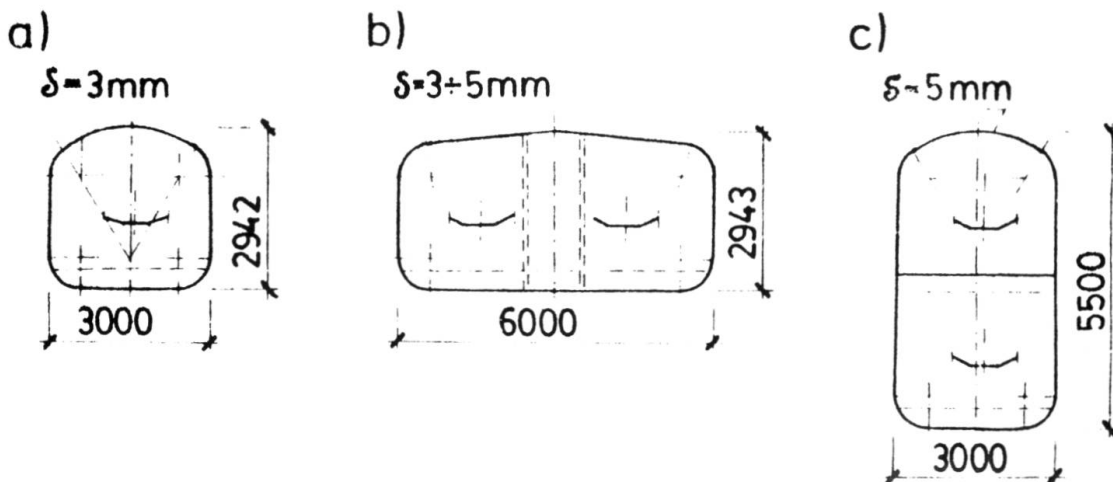

Fig. 3 Standardized contour-shapes of conveyor galleries



b) according to the limit strength of a beam determined by the development of a "plastic" hinge in a cross-section, whose tension zone is fully yielded and all the components of the compression zone lose their stability.

Band conveyor galleries, pipeline bridges and similar structures

Shell beams are often being applied as support structure of conveyor galleries connecting particular industrial units. There is one other advantage beside those previously mentioned: the carrying shell covers the inner area of a gallery; there is no need for additional lining of corrugated steel, asbestos plates, bricks and similar.

The structure consist of many identical parts, easy for standardization and series production. The fully completed gallery bay, including windows and some inner installations, is ready for transportation and erection in horizontal or a sloping position, without additional assembly and finishing.

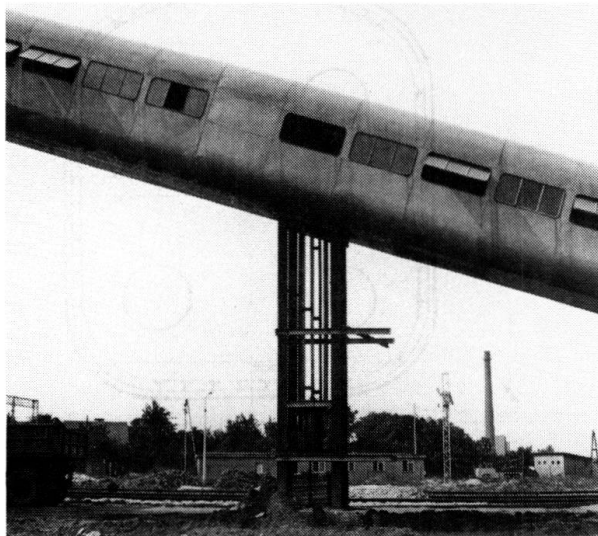

Fig. 5 General view of a gallery situated:
a) in straight line, b) in broken line

The commonly used and in Poland standardized contour-shapes are shown in Fig. 3. (a – single band, b – two bands in horizontal position, c – two bands in vertical position). The average span is 50 – 60 m (simple supported beam) and 60 – 70 m (continuous beam). More structural details of the cross-section of a shell girder can be seen in Fig. 4. as applied for conveyor gallery (Fig. 4.a) and for pipeline bridge (Fig. 4.b). Line of gallery, which is usually straight (Fig. 5.a) can also be curved without essential changes in its structural solution (Fig. 5.b).

Highway bridges

The substitution of box girders by shell girders in bridge structures can be considered as controversial; however, one can see some advantages in this case as well e.g.: more uniform torsional stress distribution under eccentric carriageway loading, higher local stability of shell (especially of the bottom part of continuous beams), natural wind firing, higher fatigue strength and better corrosion protection.

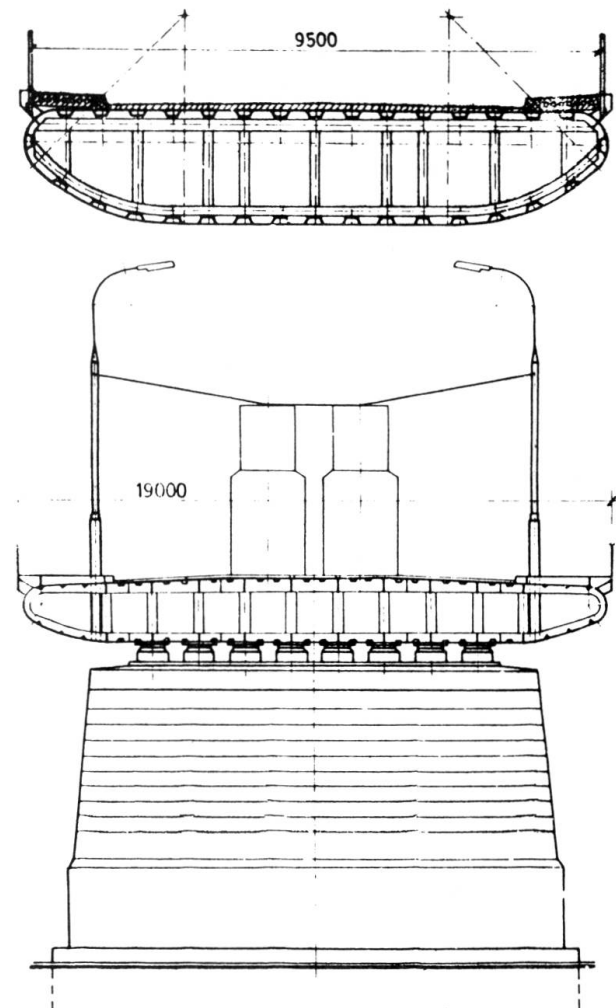

Fig. 6 Cross-section of shell beam of highway bridges:
a) for car traffic, b) for cars and tramways

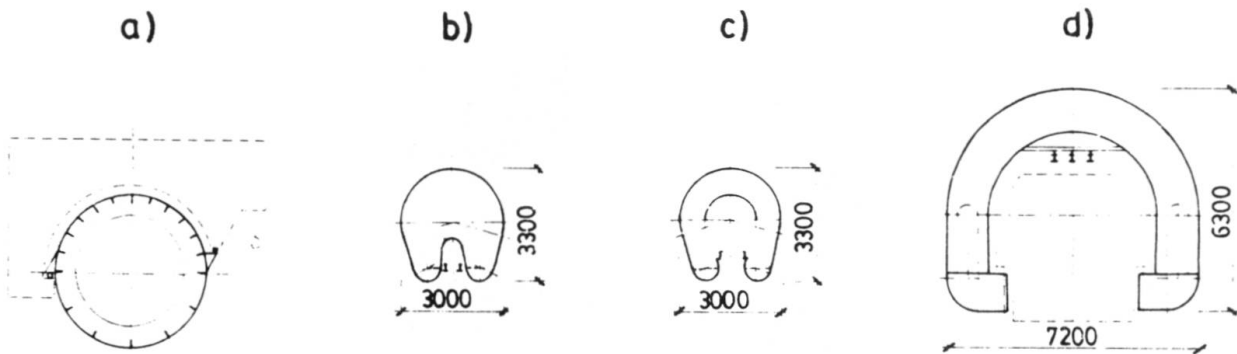

Fig. 7 Cross-sections of shell beams for travelling cranes

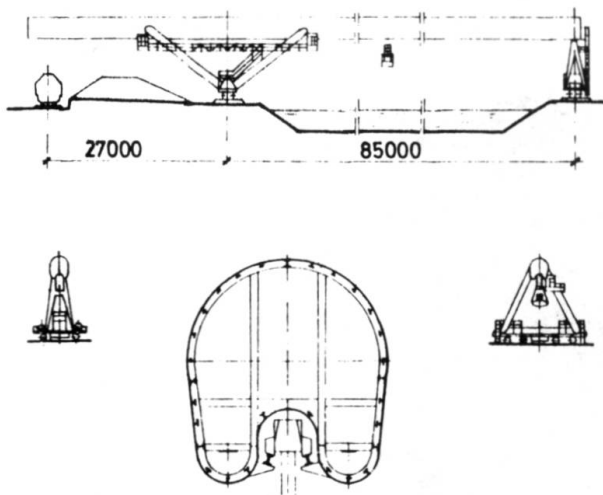

Fig. 8 Construction scheme of a gantry crane

Some projects have already been executed (Fig. 6.a,b). The upper part of the shell beam, 12 mm thick, is shaped as an orthothropical plate, covered by an asphalt layer, constituting the bridge floor.

The lower part of the shell, 8 mm thick, is more curved and less stiffened than the upper one. Both parts of the shell are additionally connected by longitudinal and transversal bracings. The general view is aesthetic and adapted to the urban environment.

Crane girders

The application of shell girders as supporting construction of cranes is profitable particularly for gantry cranes in storage places. With regard to their biaxial flexural and torsional rigidity, fatigue strength and maintenance they are better than lattice girders. Further, they are lighter and have better aerodynamic properties saving energy consumption as compared to box girders.

Some examples of cross-section shapes of executed crane girders are given in Fig. 7.: a – overhead travelling crane, b,c,d – gantry cranes of crane rating 50 kN up to 350 kN and main span 40.0 m up to 80.0 m (total length up to 130.0 m).

Fig. 8. illustrates the construction scheme of a gantry crane for coal or iron ore storage and Fig. 9. and 10. give the outlook of erected cranes and some constructional details as well. On the last picture one can compare the

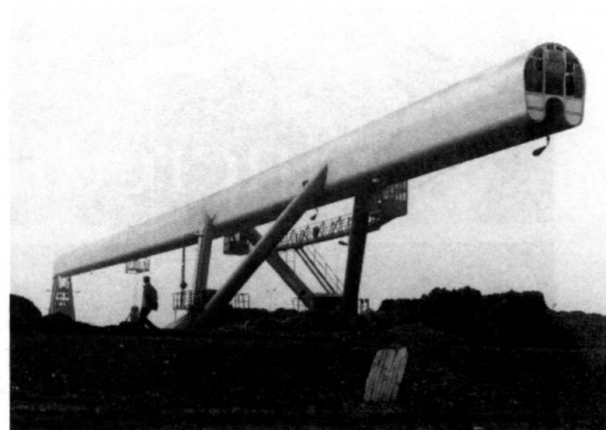

Fig. 9 General view of a gantry crane for coal storage

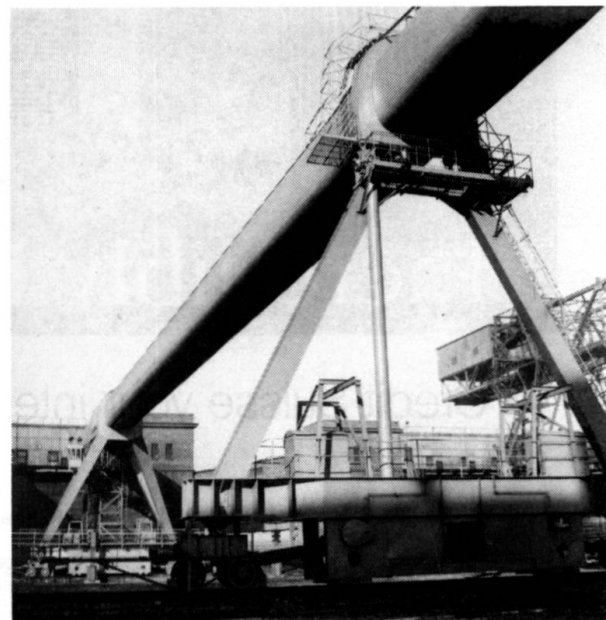

Fig. 10 General view of a gantry crane for iron ore storage

modern shell structure with a lattice one standing behind.

(Jan Augustyn)