

Sydney tower at Centrepont (Australia)

Autor(en): **Wargon, A.**

Objektyp: **Article**

Zeitschrift: **IABSE structures = Constructions AIPC = IVBH Bauwerke**

Band (Jahr): **9 (1985)**

Heft C-34: **Telecommunication towers**

PDF erstellt am: **24.09.2024**

Persistenter Link: <https://doi.org/10.5169/seals-19422>

Nutzungsbedingungen

Die ETH-Bibliothek ist Anbieterin der digitalisierten Zeitschriften. Sie besitzt keine Urheberrechte an den Inhalten der Zeitschriften. Die Rechte liegen in der Regel bei den Herausgebern.

Die auf der Plattform e-periodica veröffentlichten Dokumente stehen für nicht-kommerzielle Zwecke in Lehre und Forschung sowie für die private Nutzung frei zur Verfügung. Einzelne Dateien oder Ausdrucke aus diesem Angebot können zusammen mit diesen Nutzungsbedingungen und den korrekten Herkunftsbezeichnungen weitergegeben werden.

Das Veröffentlichen von Bildern in Print- und Online-Publikationen ist nur mit vorheriger Genehmigung der Rechteinhaber erlaubt. Die systematische Speicherung von Teilen des elektronischen Angebots auf anderen Servern bedarf ebenfalls des schriftlichen Einverständnisses der Rechteinhaber.

Haftungsausschluss

Alle Angaben erfolgen ohne Gewähr für Vollständigkeit oder Richtigkeit. Es wird keine Haftung übernommen für Schäden durch die Verwendung von Informationen aus diesem Online-Angebot oder durch das Fehlen von Informationen. Dies gilt auch für Inhalte Dritter, die über dieses Angebot zugänglich sind.



2. Sydney Tower at Centrepont (Australia)

Owner: AMP Society
Architect: Donald Crone & Associates Pty. Ltd.
Engineer: Wargon Chapman Partners Pty. Ltd.
Contractor: Concrete Constructions Pty. Ltd.
Works duration: 60 months
Service date (year): September, 1981.

The structure of Sydney Tower is rather unique in the sense that having been «tailored» to suit a particular set of circumstances and requirements, it offers a number of unconventional characteristics, which make it appear distinctly different from other world renowned towers. It can be described as a free standing cantilevered, post-tensioned, guyed steel structure.

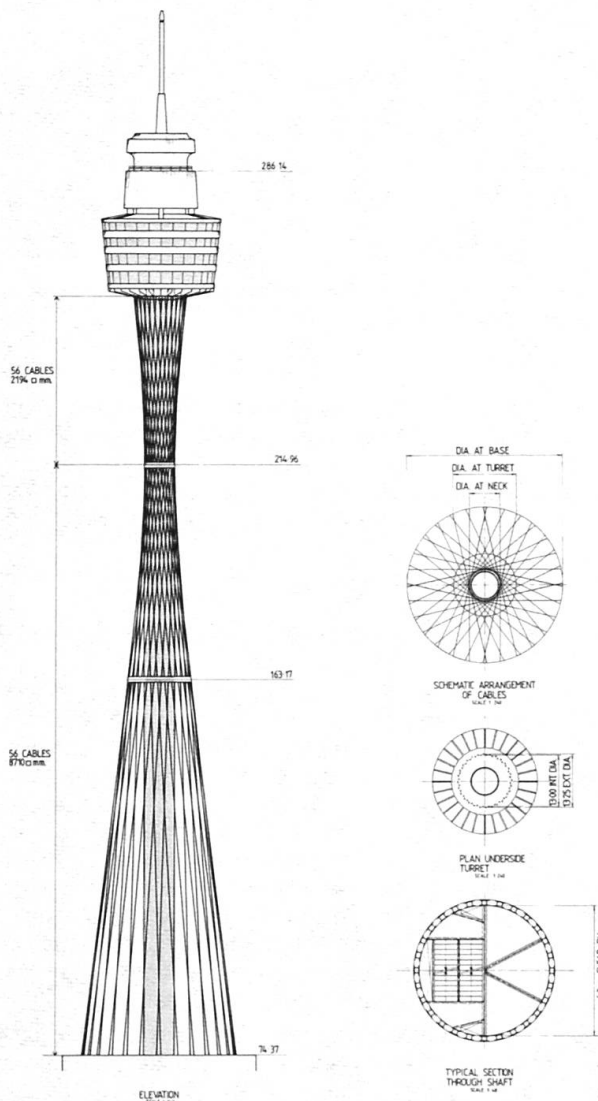

Fig. 1

Sydney Tower is basically a tourist-telecommunication facility, located in the retail heart of the City, with its captive customer market, a magnificence of scenery and a congenial "year round" climate; it is a recognised landmark, which together with Opera House and Harbour Bridge identifies Sydney on the World map.

The Tower is constructed on the top of a very large and massive concrete building, onto which a relatively light and slender structure is connected. It comprises a 6.6 m diameter shaft which houses the necessary lifts, stairs and ducts and which constitutes a slender shaft-column. The lateral stability is provided by a system of guys, an array of two opposing families of straight cables connecting to the massive base building. Such an array of cables generates a geometrical shape known as a one sheet hyperboloid of revolution. (Fig. 1)

Initial analysis of the proposed system involved consideration of a simple cantilever beam with a varying moment of inertia of the gross section of shaft and cables and it was based on quasi-static wind loading which was in excess of the requirements of the then current Interim Code and which was later identified as representing a 4000 Year Return Period Wind. It is interesting that this somewhat primitive first approach produced surprisingly accurate results, which were later confirmed by detailed analysis.

The building was designed to withstand winds occurring on a return period of 1000 years and the deformation and oscillation were limited to ensure comfort of the occupants of the tower. More specifically, it was accepted to limit infrequent acceleration to approximately 1.5% G at which level about 90% of the population will just perceive the motion.

The base structure is a multi-storey reinforced concrete building containing 25000 cubic metres of concrete, endowed with extensive shear resisting elements (shear walls). The participation of this mass of concrete in the process of stabilising the tower structure, is provided by 120/60 tonne cables incorporated in concrete walls and columns and post tensioned after the construction of the base building. A concrete ring, 1.3 m deep and 10 m wide located at the top of the concrete building constitutes the transition structure which effectively couples the tower tension cable with the concrete base building.

The central shaft is fabricated from 56 No.-250 mm x 250 mm universal columns boxed in pairs and rolled from AUSTEN 50, a 350 MPa weathering steel, produced by Broken Hill Pty. Ltd. It is prefabricated in 4.8 m high sections which include stairs, bracing, pipes and other services.

At a level of about 100 m above the top of concrete building an Intermediate Anchorage Ring (IAR) is located. This structure fulfills several functions; it simplified the erection procedure, increases stiffness and reduces the un-braced length of the central column, thus improving the global stability of the structure.

The turret is constructed of 14 fully welded steel frames, resting on a boxed base constructed of 25 mm plates and 28 outriggers which radiate to the perimeter.

A series of global analyses of the structure was conducted including static and dynamic studies and detailed analysis of stability of the structure. In addition a series of microscopic analyses were conducted in areas of potential stress concentrations.

Dynamically the structure resembles a system with two degrees of freedom, in which vibration is inhibited by the movement of an auxiliary mass. (Fig. 2)

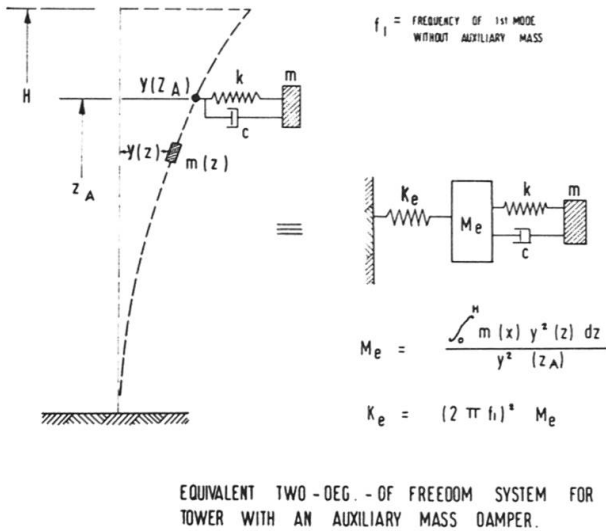

Fig. 2

Fabrication involved the welding of 350 MPa weathering steel which material was used extensively for the first time in Australia. The design of welding, fabrication, testing and inspection procedures were carefully planned.

During fabrication, some difficulties were encountered, particularly in relation to lamellar tearing of thick plates and it was necessary to apply several techniques developed in connection with welding of joints in material susceptible to lamellar tearing, such as «buttering» of joints with several layers of low strength electrodes, replacement of plate with weld metal.

All site welds were subjected to 100 percent weld procedure qualification testing and finally were 100 percent ultrasonically tested.

The prefabricated segments were machined to a tolerance of ± 0.25 mm on the cap and base plates and trial assembled prior to the delivery to site resulting in a remarkable degree of contact accuracy between bolted shaft barrels.

The highly stressed neck connectors which provide means of positively anchoring pairs of cables to the shaft at a height some 150 m above the base building, were fabricated from quenched and tempered 700 MPa yield stress steel.

The cables constitute an essential element of the structure. The 56 parallel wire cables were manufactured by BBR Australia, each cable comprises 235-7 mm dia. wires, bunched together, strapped and coiled for ease of handling during erection.

The system of guying is made up from two families of cables, one extending right to left and the other left to right, or achieve greater torsional rigidity. The cables are

constructed in three segments; the first (about 91 m in length) extends from concrete base to the IAR; the second (some 50 m long) extends from the IAR to the neck; and the third (41 m in length) extends from the neck to the underside of the turret. The total weight of the cables is approximately 700 tonnes.

The method of construction evolved around the principle of maximum prefabrication. The success of this method may be illustrated by the fact that the \$ 25000000 structure was erected on the site, by a team of 12-20 people including riggers, welders, labourers, and the supervisory staff.

The design of the Tower in general and prediction of its behaviour under wind in particular necessitated extensive research and testing. Initial work and some further studies relating to the behaviour of the tower during construction were conducted at Sydney University. An aero-elastic model was tested at the Boundary Layer Wind Tunnel at the University of Western Ontario.

The testing revealed excessive oscillation in the lift direction in the first mode, thus requiring the introduction of tuned mechanical dampers to ensure comfort of occupants. The 165000 litre water tank required by the fire authorities, was utilised as an auxiliary mass (Fig. 3) suspended on cables and restrained against lateral movement by 8 Koni shock absorbers which disperse the energy induced by wind.

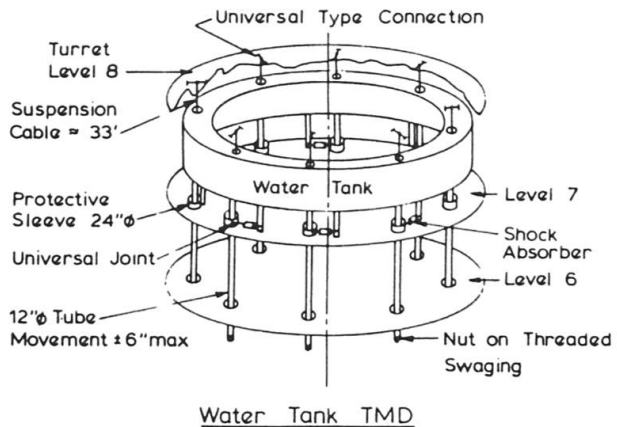

WATER TANK TMD IN SYDNEY TOWER

Fig. 3

The second mode of vibration appeared to be induced by vortex shedding and occurred in the across wind direction. The peak response in this mode was observed during wind velocities of approximately 35 m/sec. and involved movements of 50 to 75 mm at the level.

During construction, the lift compensating and trailing cables were observed to move in a manner which caused some concern, requiring partial enclosure of the lift shafts. The aerodynamic consequence of such enclosure necessitated an additional Tuned Mass Damper (tuned to the second mode) comprising a 40 tonne steel ring which is suspended on 1.2 m long rods at the Intermediate Anchorage Ring. (Fig. 4)

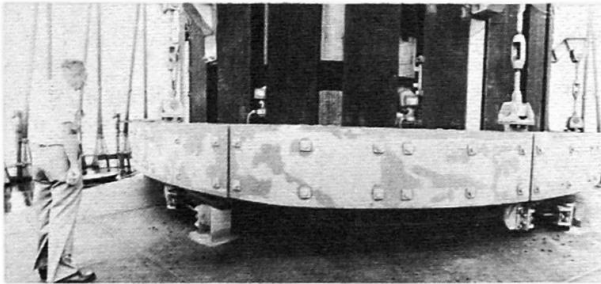

Fig. 4

The Tower is presently extensively instrumented to allow the testing of the effectiveness of the tuned mechanical dampers and the monitoring of its structural response to wind gusting. Since completion, the tower has responded very satisfactorily to buffeting by severe winds which occurred on several occasions registering gusts of up to 45 m/sec.

(A. Wargon)

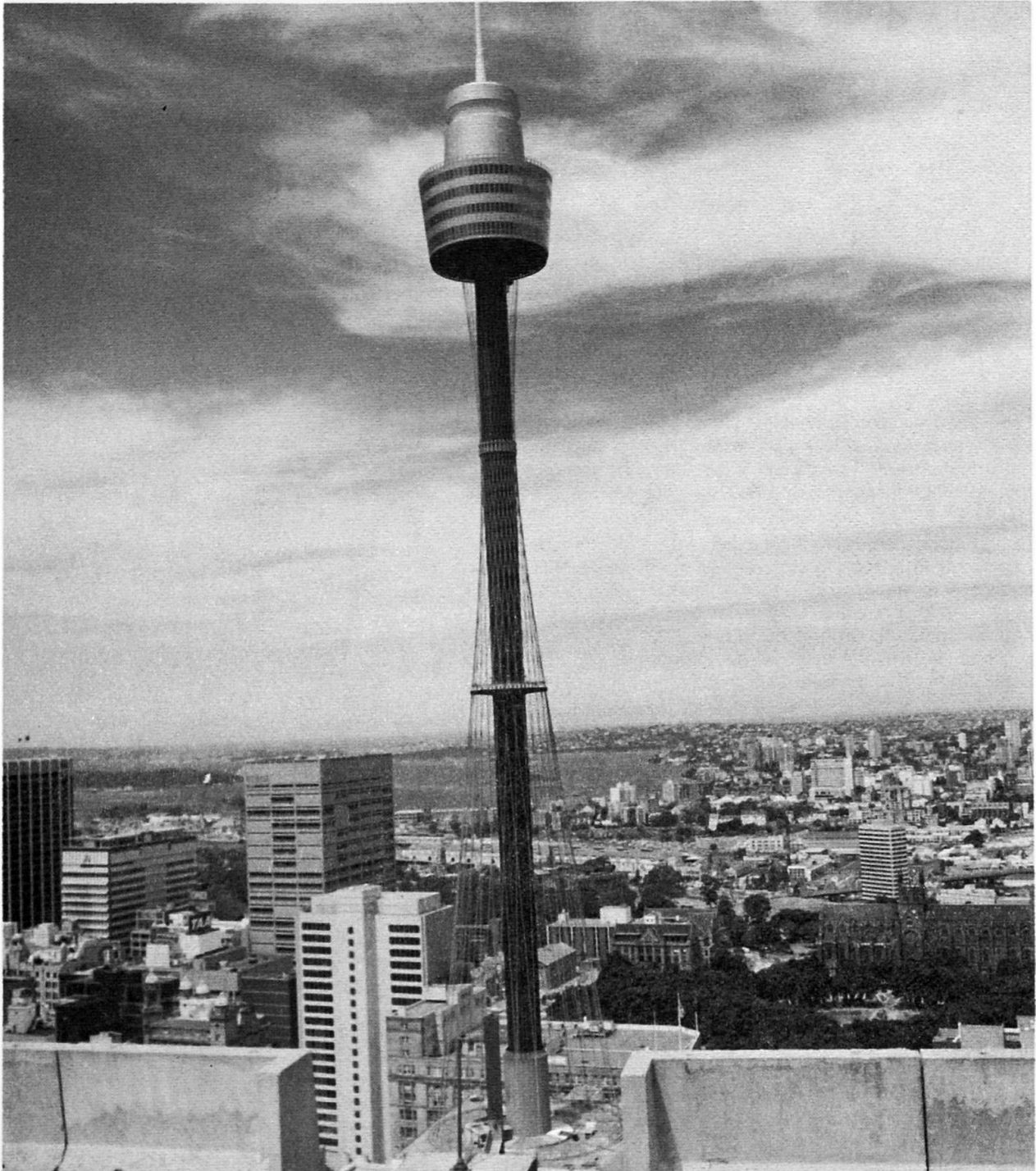

Fig. 5