

# All-welded loading crane of piper-girder types

Autor(en): **Okulov, D.P.**

Objektyp: **Article**

Zeitschrift: **IABSE structures = Constructions AIPC = IVBH Bauwerke**

Band (Jahr): **2 (1978)**

Heft C-4: **Structures in the USSR**

PDF erstellt am: **22.09.2024**

Persistenter Link: <https://doi.org/10.5169/seals-15111>

## **Nutzungsbedingungen**

Die ETH-Bibliothek ist Anbieterin der digitalisierten Zeitschriften. Sie besitzt keine Urheberrechte an den Inhalten der Zeitschriften. Die Rechte liegen in der Regel bei den Herausgebern.

Die auf der Plattform e-periodica veröffentlichten Dokumente stehen für nicht-kommerzielle Zwecke in Lehre und Forschung sowie für die private Nutzung frei zur Verfügung. Einzelne Dateien oder Ausdrucke aus diesem Angebot können zusammen mit diesen Nutzungsbedingungen und den korrekten Herkunftsbezeichnungen weitergegeben werden.

Das Veröffentlichen von Bildern in Print- und Online-Publikationen ist nur mit vorheriger Genehmigung der Rechteinhaber erlaubt. Die systematische Speicherung von Teilen des elektronischen Angebots auf anderen Servern bedarf ebenfalls des schriftlichen Einverständnisses der Rechteinhaber.

## **Haftungsausschluss**

Alle Angaben erfolgen ohne Gewähr für Vollständigkeit oder Richtigkeit. Es wird keine Haftung übernommen für Schäden durch die Verwendung von Informationen aus diesem Online-Angebot oder durch das Fehlen von Informationen. Dies gilt auch für Inhalte Dritter, die über dieses Angebot zugänglich sind.



### 18. All-Welded Loading Crane of Pipe-Girder Types

Design Institute: TSNIIproektstalkonstruksiya, USSR  
 Customer: Enterprises of Electric-power and Metallurgical Industries

**Dimensions:**

Spans: 60.0; 76.2; 90.0 m

Length of cantilevers: 12.9 – 36.5 m

Underbridge clearance: 28.5 m

Overall height: 35.3 m

Bridge overall length: 114.7 – 144.2 m

**Material:**

Steel grade used for the main structure: C 52/40; C 46/33

**Mass:**

Metal structures: 512 – 619 t

Steel consumption per ton of hour productivity of a grab truck: 0.86 – 1.03 t

Steel consumption per 1 meter of bridge length: 4.32 t

Steel consumption per 1 meter of bridge length: 4.32 t

**Loading:**

Grab truck of  $Q = 32$  t

Capacity: 600 t/hour

Total mass with a load: 133 t

A new type of loading cranes has been developed as a result of design and research and experimental works.

A rigid system with supports of equal rigidity is taken as the basis of the structure.

A metal structure (see Fig. 1) is designed as separate transportable units and consists of a two-cantilever bridge, two space supports and stairs with platforms.

Due to the fact that the main components of the structure are made as units the most part of work on assembling and welding is done at the shop and only assembling by enlarged units and welding of field joints are carried out on site.

The bridge of the loading crane consists of the main pipe and the base as a structure of two parallel traffic girders (see Fig. 2).

Two diaphragms spaced at two diameters of the pipe are welded inside the pipe, a transverse girder is welded to the lower surface of the pipe.

To provide a combined behaviour of the system "pipe + traffic girders" the upper chord plates of the traffic girders are connected to the pipe by means of a bent breaking plate which performs also the function of a lateral loading damper. The main pipe portion is directly welded to the collar-beam webs each having a corresponding slot in the place.

Each support consists of four inclined tubular members which are connected by a space supporting box in their lower part. The main components of the loading crane are made of steel with a yield point equal to 40 kg per mm<sup>2</sup>.

Mass of metal structures of such loading cranes spanned 76.2 m is 530 to 630 t.

The elevation of the bridge enlarged unit together with a grab truck of total mass up to 500 t is carried out by means of four pulley blocks fixed to erection girders, which are placed on already assembled and untightened according to the design position supports (see Fig. 3).

Field connections of the bridge to the supports may be of two types – either welded or made by high-strength bolts. The design of metal structures is carried out with due regard for a spatial behaviour with the help of computers (see Fig. 4).

Scientific researches have been carried out with the aim to reveal the main pipe shell reserves of local stability and to study analysis of the structure actual work.

(D.P. Okulov)

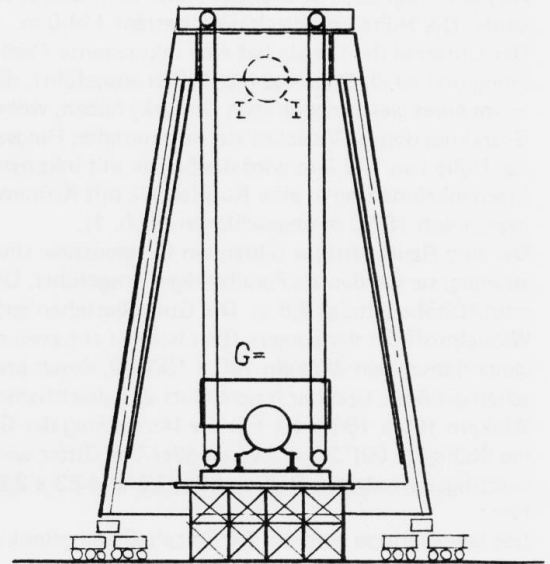

Fig. 3 Erection Diagram of the Bridge Enlarged Unit

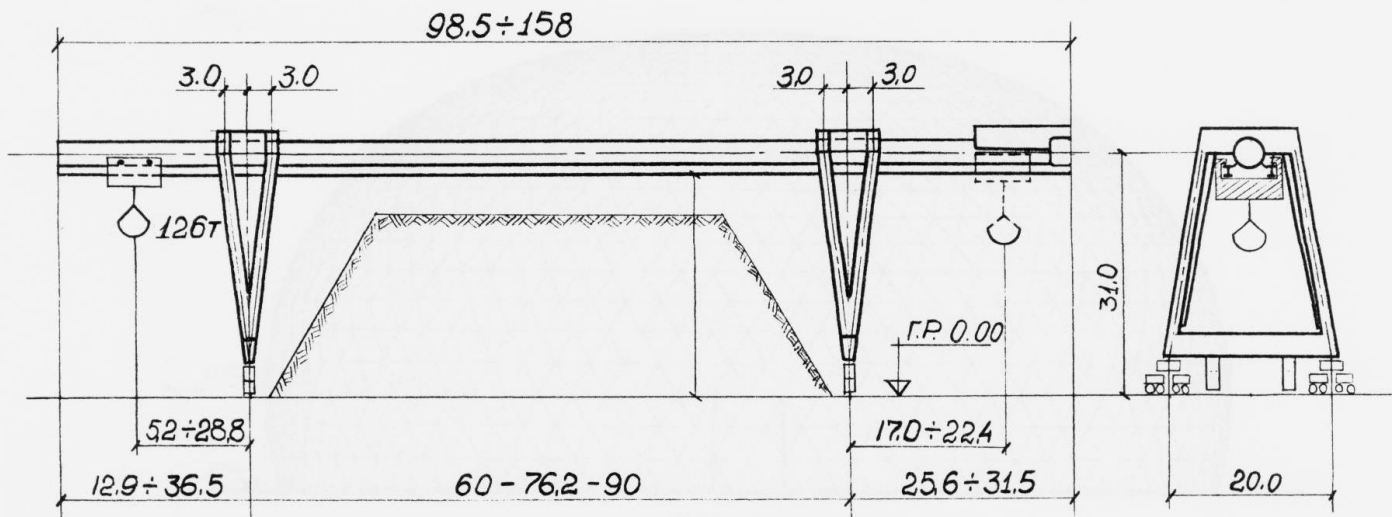

Fig. 1 A Loading Crane of a Pipe-girder Type

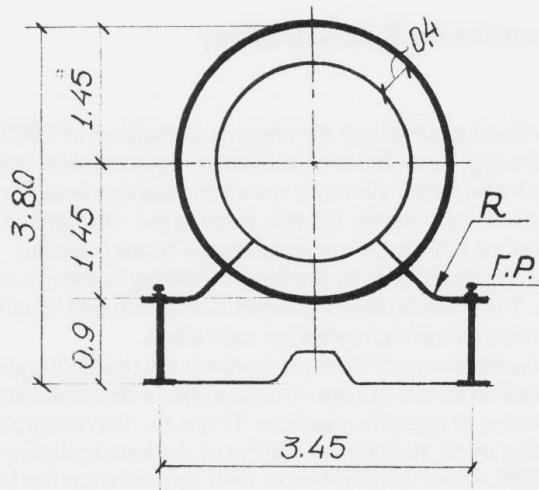

Fig. 2 Cross-sectional View of the Bridge

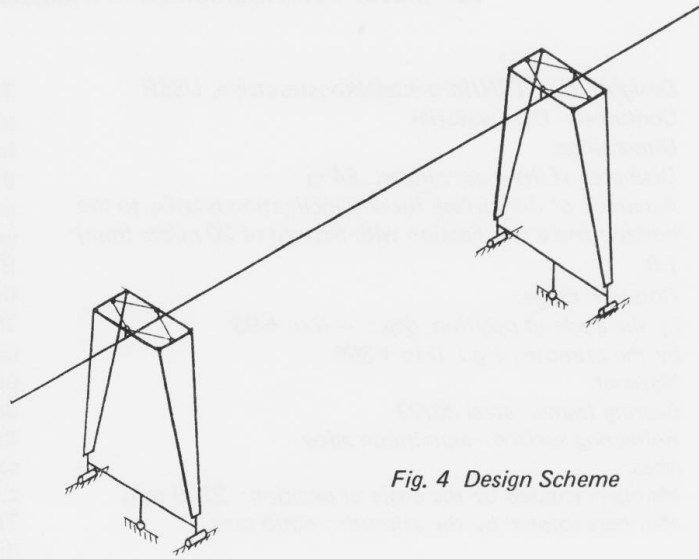

Fig. 4 Design Scheme

