

**Zeitschrift:** IABSE congress report = Rapport du congrès AIPC = IVBH  
Kongressbericht

**Band:** 14 (1992)

**Rubrik:** Seminar 1: Creative design as reflected in practical applications

### **Nutzungsbedingungen**

Die ETH-Bibliothek ist die Anbieterin der digitalisierten Zeitschriften auf E-Periodica. Sie besitzt keine Urheberrechte an den Zeitschriften und ist nicht verantwortlich für deren Inhalte. Die Rechte liegen in der Regel bei den Herausgebern beziehungsweise den externen Rechteinhabern. Das Veröffentlichen von Bildern in Print- und Online-Publikationen sowie auf Social Media-Kanälen oder Webseiten ist nur mit vorheriger Genehmigung der Rechteinhaber erlaubt. [Mehr erfahren](#)

### **Conditions d'utilisation**

L'ETH Library est le fournisseur des revues numérisées. Elle ne détient aucun droit d'auteur sur les revues et n'est pas responsable de leur contenu. En règle générale, les droits sont détenus par les éditeurs ou les détenteurs de droits externes. La reproduction d'images dans des publications imprimées ou en ligne ainsi que sur des canaux de médias sociaux ou des sites web n'est autorisée qu'avec l'accord préalable des détenteurs des droits. [En savoir plus](#)

### **Terms of use**

The ETH Library is the provider of the digitised journals. It does not own any copyrights to the journals and is not responsible for their content. The rights usually lie with the publishers or the external rights holders. Publishing images in print and online publications, as well as on social media channels or websites, is only permitted with the prior consent of the rights holders. [Find out more](#)

**Download PDF:** 15.01.2026

**ETH-Bibliothek Zürich, E-Periodica, <https://www.e-periodica.ch>**



## **Seminar 1**

**Creative Design as Reflected in Practical Applications**

**Idées créatrices dans le projet et applications pratiques**

**Kreative Entwürfe und Anwendungsbeispiele**

Leere Seite  
Blank page  
Page vide

## Pennsylvania Convention Center

Pennsylvania Convention Center

Pennsylvania Convention Center

### Henry CLARK

President  
Ross Bryan Assoc.  
Nashville, TN, USA



Henry Clark, born in 1944, received his engineering degree from Vanderbilt University. He has worked in this firm for 25 years, and the firm has a wide ranging consulting practice, involved in major projects across the United States.

### SUMMARY

The Pennsylvania Convention Center in Philadelphia is currently under construction. The design of this structure is reviewed along with construction techniques. The Center includes the renovation and adaptive reuse of the Reading Railroad Terminal which was originally constructed in 1893 as a riveted wrought iron structure. The Center has a surface area of approximately 115 000 m<sup>2</sup>, one-tenth of which is renovation and the remainder is new construction. New construction is long span and executed in concrete and structural steel.

### RÉSUMÉ

Le Palais des congrès de Pennsylvanie est en cours de construction à Philadelphie. L'article examine la conception de cet ouvrage ainsi que les techniques de construction utilisées. Cette réalisation comporte la rénovation et la réutilisation en grande halle de l'ancienne gare tête de ligne du Reading-Railroad, dont la charpente en fer forgé et riveté fut construite en 1893. Le palais couvre une surface totale de 115 000 m<sup>2</sup>, dont un dixième environ représente la partie rénovée et le reste la partie nouvellement construite. Cette dernière est réalisée en éléments d'acier et de béton structuraux de grande portée.

### ZUSAMMENFASSUNG

Das Pennsylvania Convention Center (Staatliches Messezentrum) in Philadelphia ist zur Zeit im Bau. Der Entwurf dieses Gebäudes ist hier mit seiner Bautechnik zusammen besprochen. Dieses Projekt beinhaltet die Renovierung und Anpassung der Bahnsteighalle des ehemaligen Reading-Railroad-Kopfbahnhofs auf, die im Jahre 1893 aus vernietetem Schmiedeeisen gebaut wurde. Um die Halle herum entsteht ein neunmal grösserer Neubau als Beton- und Stahlkonstruktion grosser Spannweite.





## 1. DESCRIPTION OF PROJECT

### 1.1 Development of Concept

The City of Philadelphia and the State of Pennsylvania combined resources for a convention center development in Philadelphia. A stimulus to the city and state economy was sought, and due to the rising demand for convention sites, a convention center was selected as the development project. A request for proposal was sent out to interested development groups asking for proposals and sites.

### 1.2 Selection of Team and Site

Based on proposals submitted, a team and site were selected in 1984. The team included a development group that owned the downtown historical site. Other members of the team included the construction group and architectural and engineering companies.

The site is east of City Hall at the Reading Railroad Terminal on Market Street at 12th Street. The Terminal, which opened in 1893, was to be renovated and connected across Arch Street to the north to a new Convention Hall covering four blocks between Arch and Race Streets from 11th to 13th Streets. When constructed, the Terminal was the longest three-hinged arch structure of the time.

### 1.3 Project Development

Originally, the project was to be developed by private companies and leased to the City. This was revised to control by a Convention Authority which was set up by the City and State. Construction was initially to be done in a construction management format with segments of the work designed and released as contract packages. After early releases of the concrete caissons and street removal packages, the project was revised to two single contracts, one for the new Convention Hall and one for the renovation of the Reading Terminal Shed. Despite the changes, the new Convention Hall bid at \$129,900,000.00 in December, 1990, which was within 1% of budget.

After selection of the team and site in 1984, the Pennsylvania Convention Center Authority was established. The acquisition of property, the relocation of existing businesses, and the demolition of buildings were begun.

## 2. HISTORY OF SITE

### 2.1 Philadelphia and Reading Railroad Terminal

In the 1880's, the Philadelphia and Reading Railroad set out to consolidate train traffic in downtown Philadelphia. A site along Market Street was chosen three blocks east of the city center. The site at Market Street had two important market houses for fresh foods which were to be incorporated into the Terminal structure. The markets remained open during construction as their new space was built to the north which allowed them to move and reopen immediately before their facilities were torn down. This same concept will be followed 100 years later, as the current Market tenants will operate as the Shed is renovated.

Trains were elevated on viaducts in the city, which required the terminal floor to be over the new Market space some 7.5 meters above street level. Thirteen tracks were planned in the Terminal with passenger platforms between them. The Terminal Shed roof is a three-hinged arch constructed of riveted wrought iron. Twin arch trusses are spaced at 15.3 meters apart and span 79.2 meters from



center to center of base pins. The center pin of the arches is 27 meters above the base pins. The arch bases are tied together with wrought iron eye bars as tension ties.

The Terminal and Head House were designed by the Wilson Brothers and Company. Analysis of the Terminal roof was done graphically and the original drawings remain. Analysis was done for the following load combinations.

- First: Snow on one side and dead load
- Second: Snow on both sides and dead load
- Third Wind on one side and dead load
- Fourth: Snow and wind on one side, snow only on other side and dead load

Snow loading was assumed at 12 psf with wind pressure taken to be 35 psf against a vertical surface.

Mr. Joseph M. Wilson presented a paper describing the design of the Terminal and Head House to the 1895 annual convention of the American Society of Civil Engineers. The original ink on linen drawings of the buildings were retained by the railroad in the Head House until 1985 when they were given to the Athenaeum, a historical repository in Philadelphia. These drawings have been invaluable in the design of the Terminal Renovation.

### 2.1 Adjoining Convention Hall Site

The city center of Philadelphia has had significant commercial development for over two hundred years. Hence, the four blocks for the Convention Hall had the potential for various foundation structures to be present. Fortunately, historical documents of various site utilizations minimized problems. An engineered earth fill 1.22 meters thick was placed over the rubble fill which is in place for much of the site. This provided a leveling of the site and a bridge over localized soft spots. Drilled concrete caissons were utilized to carry building loads to the underlying rock.

## 3. PROJECT DESIGN

### 3.1 Convention Hall Design

The Reading Terminal was to be used for ballroom, meeting and assembly functions. The Convention Hall was designed to have 30,000 square meters of display space for large conventions and trade shows. The two facilities are tied together with a three-story building bridge across Arch Street.

The Convention Hall was placed on the second floor in a similar fashion to the original train layout to the Terminal. This allows for a one level connection between the Exhibit Hall and the Terminal facilities. The ground floor of the Hall has parking, administrative, kitchen, and meeting spaces.

Numerous layouts were studied for the Convention Hall, and the final design was to use a 18.3 x 18.3 meter column spacing on grade and a 36.6 x 36.6 meter column spacing from the second floor to the roof. The second floor is framed with concrete, and the roof utilizes a steel truss system. The Hall construction closed Cherry Street running east-west but bridged over 12th Street to allow this north-south artery to remain with its vehicular and trolley service.

The Convention Hall is supplied by trucks which utilize a ramp to approach from the north. This ramp follows the plan of the original train viaduct. The trucks arrive on an apron structure which allows movement east and west to various



portions of the Hall, and three ramps allow access into the Hall for delivery or pickup of displays. The truck apron is designed to carry highway loading, so fully loaded trucks can drive directly from the highway across the apron into the Convention Hall.

Along the southern edge of the Hall is a Concourse to allow pedestrian entrance and distribution to the Hall level from the street level. Access to the site is available by commuter train under the Terminal, by automobile, or by electric trolley that passes beneath the Hall on 12th Street.

### 3.2 Selection of Structural Systems

Design loads for the Hall, Apron, and Concourse are as follows.

Convention Hall	1709 kg/sq. meter
Apron	AASHTO HS: 20
Concourse	488 kg/sq. meter

The heavy Hall loading is the result of larger shows of heavy equipment and the developing practice of double or triple stacking in exhibits to lower exhibit floor space costs. This heavy loading allows trucks to move into the display space to unload and this also allowed construction of the Convention Hall roof off of the elevated floor.

A number of structural systems were studied for the Hall floor including structural steel and concrete. A conventionally reinforced beam and girder concrete system was chosen. The floor slab is 20.3 cm thick and spans between the 80.5 x 147 cm deep beams. The beams are carried by girders 1.52 meters by 1.8 meters deep at the columns and 1.5 meters deep through midspan.

Ducts are placed in the beams and girders between floor boxes to provide distribution of water, electrical power, and compressed air to convention exhibitors. Floor boxes are placed on four sides of each column that extends to the roof and at a 9.2 x 9.2 meter grid between. The design drawings detailed reinforcing placement in the girders at columns to provide space for the floor boxes.

During construction, the general contractor requested permission to cast the girders up to the bottom of the floor boxes and below the top steel first. The beams were part of a secondary cast that included the slab and the tops of the girders. The contractor chose a moveable formwork system for casting of a bay of beams. By staging the form removal on the girders and placing reshores as form segments were removed, we were able to accommodate the contractor's request. Bottom and side bars for the beams were doweled out of the sides of the girders to lap with the beam steel.

The Hall floor and roof span over 12th Street, which remained from previous street layouts. This provides for a continuous Convention Hall over 256 meters in length from east to west.

The Convention Hall roof with a 36.6 x 36.6 meter grid was designed with 1.5 meter deep trusses spanning to a pair of bowstring steel trusses. The transverse trusses follow the shape of the top chord of the bowstring trusses. This develops a shape similar to the Reading Terminal and provides for large open areas in the Hall.

The bowstring shaped main roof trusses reach a maximum depth of 7 meters which precludes their transportation over the road from a fabrication plant to the site. The trusses were designed in prefabricated sections to be assembled at the



site on the Convention Hall floor. The floor capacity allows for this fabrication and loads imposed by cranes erecting the completed trusses. The trusses were set in pairs along a 36.6 meter column line. A bow tie section over the column and extending 4.6 meters into each span was prefabricated and erected on the column. The top and bottom chords of the 27.4 meter remainder of the trusses were prefabricated together with their horizontal truss elements. These sections are shipped to the site, then welded together with diagonals and verticals to form the main truss section. This center section is then lifted and erected to the bow tie section over the columns. This technique was followed in construction as anticipated in design.

The truck apron utilizes structural steel and a composite concrete slab upon which a waterproofing membrane and a concrete wearing slab are placed. This area is separated by an east-west expansion joint from the Hall, although it is supported by the Hall structure using sliding bearings. The apron progressed as the Hall was started and was used to distribute material to the Hall construction. The support of the Apron on the hall girder provides a cantilever moment which balances loading and moments on the exterior column from the Hall itself.

The Concourse is framed in concrete and is separated from the Hall with an expansion joint. That location to the Concourse is supported on the Hall framing using sliding bearings.

Due to the heavy column loads of the Convention Hall, a deep foundation system was required to bear on rock. Concrete caissons were selected. Caissons ranged from 9 to 32 meters in length and from 1.22 to 1.83 meters in diameter. Bearing of caissons was enhanced by either socketing into rock or bellling the shafts out to enlarge the base. Bearing pressure was 5.74 MPa on approved rock strata.

### 3.3 Investigation of Reading Terminal

Contamination with toxic materials proved to be a problem with the Terminal. PCBs were present from the train brake fluid which leaked into the track areas inside the Terminal and in the Viaduct areas. Complete removal of the PCBs was required before the Terminal could be completely investigated. This removal slowed the transfer of the property and subsequent construction. Additionally, leaded paint was present on the wrought iron in the Terminal, which eliminated sandblasting as a cleaning procedure due to costs. Asbestos was present in the roofing, which slowed its removal and increased costs as well.

The Terminal had been maintained for the bulk of its 100-year life by the Reading Railroad. In the last ten years, maintenance had decreased and deterioration had begun to accelerate. As the roofing and the sheathing came apart, water increasingly gained access through the roof. The Terminal floor framing is very heavy since it was designed for train loads; therefore, most sections retain sufficient residual capacity for existing and new loading.

Columns were a primary concern because of load-carrying capacity and the fact that section loss is present at the Market floor and the Terminal level. A concrete encasement to supplement capacity was developed for the basement level. Preserving the historical appearance of this landmark structure required the column to remain as close to its original shape through the Market. To provide for fire resistance, the column will be painted with intumescent paint, and four sprinkler heads will be provided to flood each column in case of fire.

The roof arches have various levels of deterioration which become more prominent toward the north end, which is open. Repairs which Reading Railroad has made over the years have been made by welding in new sections of plate or angle as



required to replace the deteriorated section. Generally, considering the age of the roof, the trusses were in good condition. The tension tie elements have varying stages of section loss due to rusting. A secondary system of tie rods will be added to assure the integrity of the arches.

The trusses have one fixed bearing and one expansion bearing. The expansion bearings have various levels of corrosion and appear to be frozen. Bases will be lifted and a sliding bearing will be placed at the expansion side.

The roof trusses and structure have three east-west expansion joints which will be maintained during the renovation. The track floor has numerous expansion joints which will not be required as the structure will be enclosed by the renovation. Floor joints that line up with the roof joints will remain, while the remainder will not.

#### 3.4 Design of Terminal Renovation & Expansion

Floor members in the track floor which have lost section beyond capacity will be removed and replaced before the new concrete slab is placed. The track stringers are lower than the platform sections, so knee wall frames of angles will be used to create a bearing for the new floor slab metal deck.

Two new levels of framing are being added to sections at the north end. Those areas are steel framed with semi-lightweight concrete slabs to minimize dead load impact to the existing structure of the Shed. The larger level is the Ballroom floor while the remaining areas are used for mechanical service and other support functions.

The renovation and new construction will be done in three phases as Market tenants are moved out of a section into temporary quarters on the south side of Filbert Street. This will continue the tradition of keeping the Market open as the original builders did 100 years ago. Repair of columns and Market framing will be performed while tenants are out of their respective spaces. Care is being taken to preserve the look of the Market and its historical significance. The Market will be refurbished and ready for its second 100 years of service to the Philadelphia community as well as to visitors from around the world.

#### REFERENCES

1. WILSON, JOSEPH M.: The Philadelphia and Reading Terminal Railroad and Station in Philadelphia, ASCE Transactions 757, August, 1895.



### Legislative Assembly Hall at Gandhinagar, Gujarat, India

Salle de l'assemblée législative à Gandhinagar, Inde

Halle der gesetzgebenden Körperschaft in Gandhinagar, Indien

**S.G. JOGLEKAR**  
Princ. Consult.  
STUP Consult. Ltd.  
Bombay, India



S.G. Joglekar, born 1941, obtained his Masters in Science from U.K.. At STUP Consultants Ltd., he has been actively involved in the design and construction of major bridges, hydraulic structures, industrial and nuclear projects.

**H.K. MEWADA**  
Ret. Chief & Advisor  
Government of Gujarat  
Gandhinagar India



H.K. Mewada, born 1921, got Masters Degree in Architecture at Cornell in 1948 followed by Masters in City Planning at Illinois, USA. Starting his career with the capital city of Chandigarh, Punjab, he soon became a leading Town Planner & Architect working for the States of U.P., Assam, Rajasthan and finally for Gujarat. He had been a president of the Institute of Town Planners, India.

#### SUMMARY

The legislative Assembly Hall of Gujarat, India is an outstanding example of the complete synthesis of Architecture and structure. The architectural forms evolved following the function and mouldability of reinforced concrete have been used to create aesthetically beautiful yet structurally highly efficient forms bringing the Architect's daring vision into concrete reality.

#### RÉSUMÉ

La Salle de l'assemblée législative de Gujarat, Inde, est un modèle remarquable de synthèse totale d'architecture et de structure. Les formes architecturales se sont développées selon la fonction et l'aptitude au moulage du béton armé et ont été utilisées pour donner aux ouvrages une beauté esthétique tout en leur assurant une haute efficacité structurale. Ainsi, la vision audacieuse de l'architecte est transformée en réalité concrète.

#### ZUSAMMENFASSUNG

Die Halle der gesetzgebenden Körperschaft von Gujarat ist ein herausragendes Beispiel für die vollkommene Synthese von Architektur und Tragwerk. Die architektonische Form entwickelte sich aus der Funktion, die Formbarkeit von Stahlbeton schuf gleichermassen ein ästhetisch ansprechendes wie konstruktive hocheffizientes Tragwerk. So wurde die mutige Vision der Architekten in Beton gegossene Realität.



## 1. GENERAL BACKDROP

### 1.1 New capital city of Gandhinagar

After formation of a separate state in 1960, the government of Gujarat decided to construct the new city of Gandhinagar as a twin city to Ahmedabad which is the cultural and business centre of Gujarat. As a State capital it was to be planned and developed to achieve social integration of diverse groups and classes of society while creating for them a modern spacious habitat with emphasis on controlling population density and having open and green surroundings, free of environmental pollutions typical of newly growing metropolis. After 25 years of its development, Gandhinagar reflects and represents in its architectural style, the modern culture where function gets precedence over everything else and the scarce resources are deployed in cost-effective manner. The architectural style adopted for most of the government buildings exhibits structural concrete skeletal members such as columns, beams etc. with infilled panels of exposed brick or brick finish. The use of special finishing items is restricted to need-based situations. Form finished concrete is used extensively in interiors like ceiling and beams.

This basic concept was retained as a guiding principle, in planning the new Legislative Assembly Complex with the assembly hall, the offices for ministers and large number of departments. At the same time, it was recognised that the structure representing the highest seat of government has to be monumental in its conception befitting the achievements and the riches of the society governed from it. The integration of modern brutalism in architecture together with the search for beauty in forms and shapes so typical of Indian tradition and overall conception planned on spacious Mughal style has led to the creation of a masterpiece in architectural and structural engineering where one of the most beautiful and yet wholly functional monument is created.

## 2. FUNCTIONAL NEEDS AND SOME ASPECTS OF PLANNING

The entire complex is spread over 7,50,000 m<sup>2</sup> of land and comprises of 14 multi-storied office blocks providing 10,00,000 m<sup>2</sup> area for housing various governmental departments. At its centre, which is also the centre of the town, is located the Assembly Building on a raised platform, called the podium in Mughal style (Ref. fig.1).

The podium is a 120 m x 120 m x 5 m high structure separated from the surrounding by an artificial pond. This pond apart from beautifying the surrounding serves to restrict the access to the assembly building to limited locations thereby making safety controls easier to manage. From this podium, springs the assembly building which is in the form of a hollow square (Ref. fig. 2). At the centre of the hollow square is the Assembly hall which is a circular shaped structure. It is a separate and distinct structure within the assembly building and yet interconnected and integrated into one unit

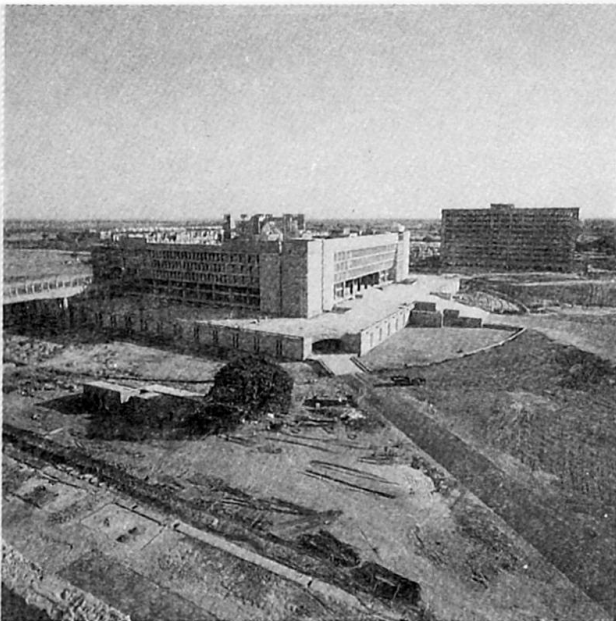
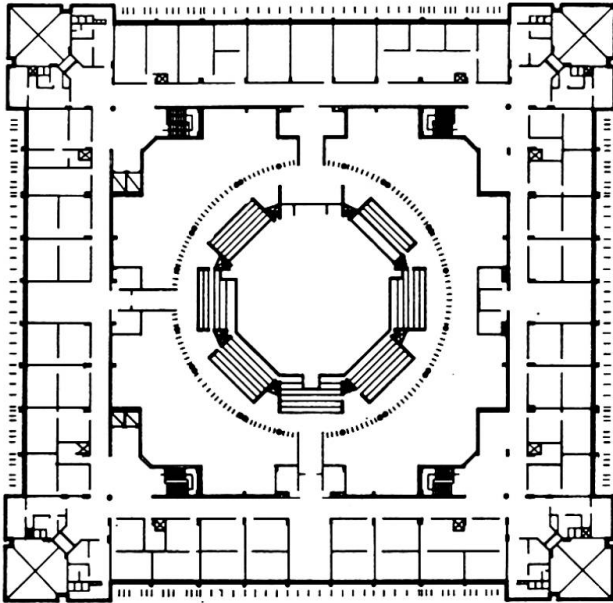

Fig.1 Assembly Building - A bird's eye-view



**Fig.2** Assembly Hall within Assembly Building

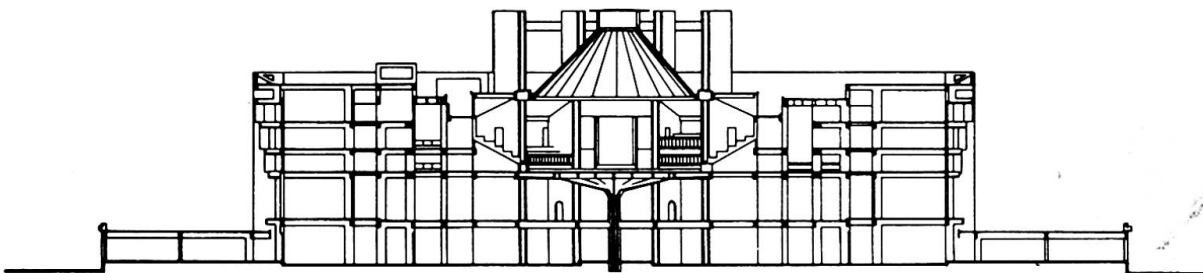

**Fig.3** View of Assembly Hall from podium level

with the wings of the surrounding hollow square by full floor at podium level and covered roof slab at 5th floor level over the gap between the assembly hall and the wings on all sides. A view of the Assembly Hall from the podium is shown in fig. 3. The assembly hall is also connected to wings at the assembly level and visitors' galleries level by walkway links.

The entire assembly block is connected to the secretarial office buildings by two 110 m long foot bridges on either side at the level of the assembly hall. One of which can be seen in fig. 1. Section taken in fig. 4 shows the Assembly Hall which is located at the 2nd floor level above the podium. The main hall provides seating for 232 legislators and is surrounded by circulating space all around which is exclusively used by the legislators. The offices of the speaker, deputy speaker, the chief minister and other ministers are located in the surrounding wings at this level.

The 3rd floor level of the hall above the podium is provided with visitors



**Fig.4** Central Section through Assembly Building



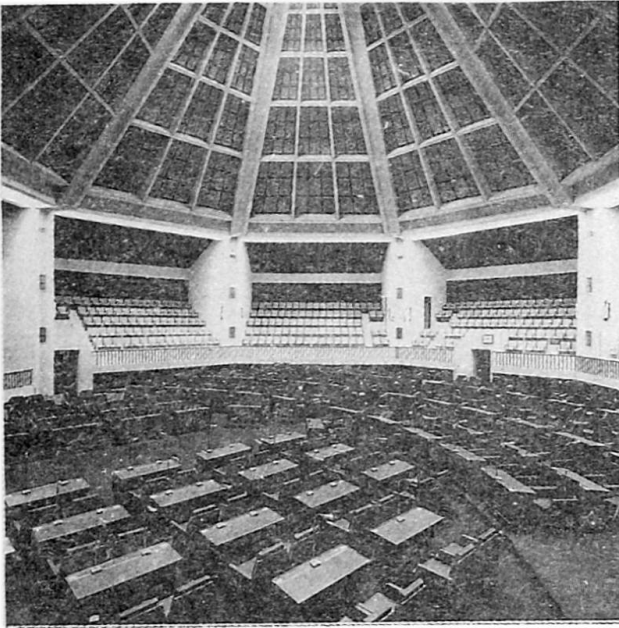

Fig.5 View of Assembly Floor and visitors galleries



Fig.6 The stylised flower supporting Assembly Floor

galleries seating 600 visitors. The galleries for press and officials assisting the ministers during the session are also provided. These galleries are accessible from the surrounding circulating spaces at the 3rd floor level which in turn is connected to the wings on 3 sides. The direct intermixing of legislators and visitors is thus avoided. This is a functional and a security requirement.

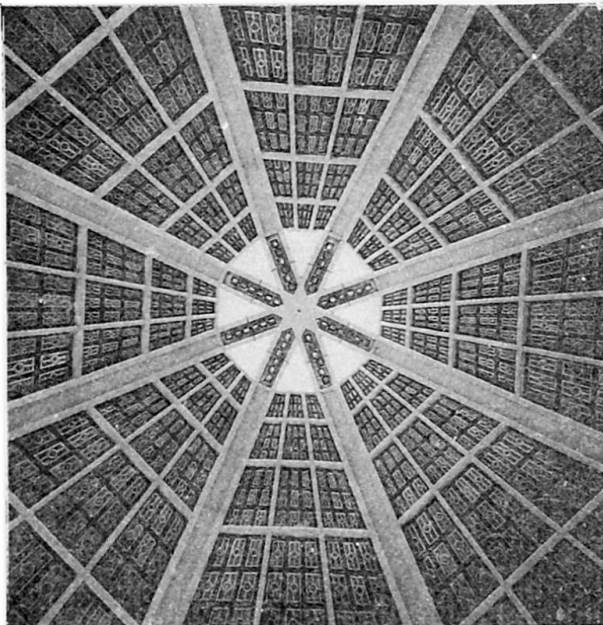

Fig.7 Structural Division, Acoustic panels and central lighting of dome

The hall is roofed over by an octagonal dome in the shape of a frustum of a cone. This dome springs from the 8 number of corbel-brackets leaving a clear gap between the roof slab and the dome on all sides of the assembly hall giving an impression of a floating dome. It has a central sky-light. The natural light taken from the eight sides and the central skylight gives uniform and adequate lighting on the assembly floor. An overall view of the assembly floor, the visitors' galleries and the roof dome is seen in fig. 5.

### 3. THE STRUCTURAL ARRANGEMENT OF THE ASSEMBLY HALL

The 42 m diameter assembly hall is structurally separated from the surrounding building and is supported on 8 main 'V' shaped columns going to the full 40 m height of the structure,



the central column going upto the 2nd floor supporting assembly floor and four other columns stopping below the podium floor. Each floor is supported on main beams spanning between the columns and cantilevers out beyond 'V' shaped columns to support the circular circulating spaces. The space between main beams is sub-divided by ribs or secondary beams which form part of the ribbed slab system spanning between the main beams. The selection of the ribbed slab system has two advantages. It subdivides the space creating strong visual-patterns for the ceiling of each floor and also led to structurally efficient slab system where stiffness and economy of reinforcing steel was achieved by providing the larger depth of ribs. The thickness of the slab portion could then be reduced to bare minimum of 80 mm which is the practical limit for construction of cast-in-situ slab and for embedding electrical conduits. The economy of the system becomes obvious by the fact that the equivalent concrete thickness of ribbed slab is under 100 mm.

The main assembly floor is supported on eight 'V' shaped columns and the central column. As seen from the podium floor (fig. 6) the central column rises from the center of the foyer into radiating, reinforced concrete beam pattern which is further sub-divided by rib-beams to form a delicate stylised flower. The floral pattern derives its significance in Indian mythology in the sense that the Goddess of wealth and prosperity 'Laxmi' has chosen "Lotus flower" as her seat. Hence this has become an apt and suggestive architectural motif. The inclined cover slab visible in photograph is a part of the structural rib-slab system which is cast in-situ and merges into the flat portion. Over this inclined portion the slab supporting assembly is made from precast panels supported between the beams. This assembly floor provided at one level retains the flexibility in arranging or rearranging the seating arrangement. The circular passage surrounding the meeting hall is provided with visual barrier on outer periphery in the form of vertical fins fixed all around which helps to define the central assembly hall as seen from the podium and also provides a visual barrier as seen in fig. 3. These fins are virtually the only non-structural RCC elements of the hall.

The visitors galleries supported on and between main 8 'V' shaped columns are classic examples of "function determining the form". The galleries are inverted folded plate units following the shape of the seating and in the form of an inverted two sides of a triangle. The location of door openings on different sides have been different thus creating a discontinuity at the lower cut-out part of the inclined plate. This portion has, therefore, been designed as a cantilever hanging portion from the folded plate, thereby giving total flexibility to the architect for selecting any suitable location of the doors. The circulating space around the galleries is supported on cantilevering rib slabs system.

The octagonal floating dome roofing over the meeting hall is supported on eight brackets cantilevering from 'V' columns. The four number of intersecting portals forming 8 corners of the dome are cast integrally with the brackets. Each of the eight 'sides' is the rib-slab system proportioned in such a way as to give a beautiful pattern as seen from below (ref. fig. 7) This rib-slab system is provided from the edge of the bracket upto the central skylight, thereby giving openings to natural light on all 8 sides at the bottom and the skylight at the top. The panels formed in between the ribs of rib-slab are used for fixing acoustic panels which also had been fixed in a matching pattern. This cladding is the only non-structural finishing item for the legislative meeting hall.

The eight 'V' columns projecting above the roof have cantilevered beams extending upto the central skylight. These beams create an impression as if



the central dome is suspended from these beams slab over the assembly hall.

#### 4. AIRCONDITIONING AND LIGHTING

The airconditioning of the assembly hall is handled in an ingenious way. Eight numbers of units are located over the roof level in triangular rooms formed by enclosing the 3rd side of 'V' columns projecting above the roof. These units take return air directly from the duct formed within the crook of the V notch of main column by providing an enclosing partition. The blower pipes are also fitted within the duct. The openings for return air and feeders in the assembly hall are provided in 'V' columns. These can be seen in fig.5. This neatly hidden air conditioning system has avoided a maze of ducts and the false ceiling. It has also led to a considerable reduction in cost.

The artificial lighting is similarly simplified. At the crown of the dome number of halogen luminaires are fitted in shape of a star (fig. 7) which is the only source of general artificial light for the assembly floor. This single source is able to light the entire hall and the galleries.

#### 5. THE FINISHING ITEMS

With the exception of the partition brick walls, peripheral fins and the acoustic treatment of dome, all other surfaces and forms are provided by structural concrete, thus achieving a total synthesis of the architecture and structure. The form-finished concrete is painted over by neat cement paint to achieve uniformity in colour shade.

#### 6. ANALYSIS & DESIGN

The analysis of this 3-D frame structure was carried out using combination of 3-D beam elements and shear wall effects provided by 'V' shaped columns. The rib slab system is analysed and designed as a system spanning between the main beam system. Structural grade of concrete used is of 20 N/Sq.mm cube strength for the entire construction. Cold twisted bars of grade 415 N/sq.mm have been used as reinforcement.

The external cladding of this assembly complex and the office buildings is provided by fine grained sand stone of light pink colour in order to achieve rich finish as well as to minimise the cleaning and maintenance costs thus combining functionality and beauty. The exposed form-finished concrete is used everywhere.

The end structure is extremely light for such spans. If total concrete used is spread uniformly over the total floor area constructed it will be of 180 mm thickness.

#### 7. CONCLUSION

As can be seen from the above description and photographs the Legislative Assembly Hall is a beautiful synthesis of architecture and structure. In the process of its planning the form has followed the function and combination of structural efficiency and aesthetically expressive forms brought an architect's daring vision into a concrete reality.

## Sense and Quality of Engineering Design

Sens et qualité des ouvrages de génie civil

Sinn und Schönheit im Ingenieurentwurf

**Juan J. ARENAS**  
Chairman  
APIA XXI  
Santander, Spain



J.J. Arenas, born in 1940, is since 1976 professor of structures at Santander University, where he has been engaged in the study of nonlinear behaviour of reinforced and prestressed concrete structures, as well as in the history of bridges. In 1987 he founded, with M.J. Pantaleón, APIA XXI, a civil engineering design firm.

**Marcos J. PANTALEÓN**  
Vice-Chairman  
APIA XXI  
Santander, Spain



M.J. Pantaleón, born in 1955, is since 1985 professor of structures at Santander University where he has worked on the study of buckling of stiffened steel plates and cable structures. Co-founder of APIA XXI in 1987

### SUMMARY

In this paper, we emphasise the increasing need for the aesthetic aspect of civil engineering works to be considered, as opposed to the purely functional criteria which were formerly used by engineers to assess these works. The aesthetic side of civil engineering should not be seen merely as something separate from the functional merits of the work, but rather as the external expression of the inner structural design. We conclude with the idea that beauty should feature in the list of the engineer's priorities.

### RÉSUMÉ

Face à une valorisation prédominante des valeurs fonctionnelles, cette contribution souligne l'importance croissante de la qualité esthétique des ouvrages de génie civil, dont la beauté doit venir non des interventions décoratives mais plutôt d'une bonne expression externe des valeurs internes dérivées de la conception et l'ordre du projet.

### ZUSAMMENFASSUNG

Bei diesen Ausführungen möchten wir auf die wachsende Notwendigkeit hinweisen, den ästhetischen Aspekt bei Hochbauarbeiten zu berücksichtigen, anstatt wie früher üblich nur dem rein Praktischen Bedeutung beizumessen. Die ästhetische Seite des Hochbaus sollte nicht getrennt vom praktischen Wert der Arbeit betrachtet werden, sondern vielmehr als die äußere Form des inneren Baumusters. Zusammenfassend sei gesagt, daß die Schönheit unbedingt eines der Anliegen bei der Ausführung von Hochbauarbeiten sein sollte.





Civil engineering, as an academic and professional degree, was created in France, about 1750, with the foundation of the Ecole des Ponts et Chaussées. Historically, this was a turning point where engineers branched out from architects. Up to this time, the word engineer was only assigned to military, planning fortresses. The only known profession dealing with construction, houses, roads or bridges, was architecture. For example, the beautiful bridge over the Loire river at Blois, was built by Gabriel, whose position was "The King's First Architect".

Architecture at that moment was mainly characterized by the use of decorative arts. Civil engineering arose then as a search of scientific knowledge that would lead to rationalist design as opposed to the empirical rules used up to that moment.

We should remember that at this time massive stone bridges, not very far from the Roman arches were still built. It was Perronet, first Dean of the French school, who undertook an experimental research that allowed him to build very slender vaults. He understood, for the first time, the mechanism of distribution of the trust force among the pier head and the two vaults springing from it. Almost heretically, he could conclude that "a more slender pier means more safety for the bridge". Those were technical advances but, for example, the neutral fiber of a plan cross section was not to be known until about 1815, when Navier, professor of the Paris School, brought it into being.

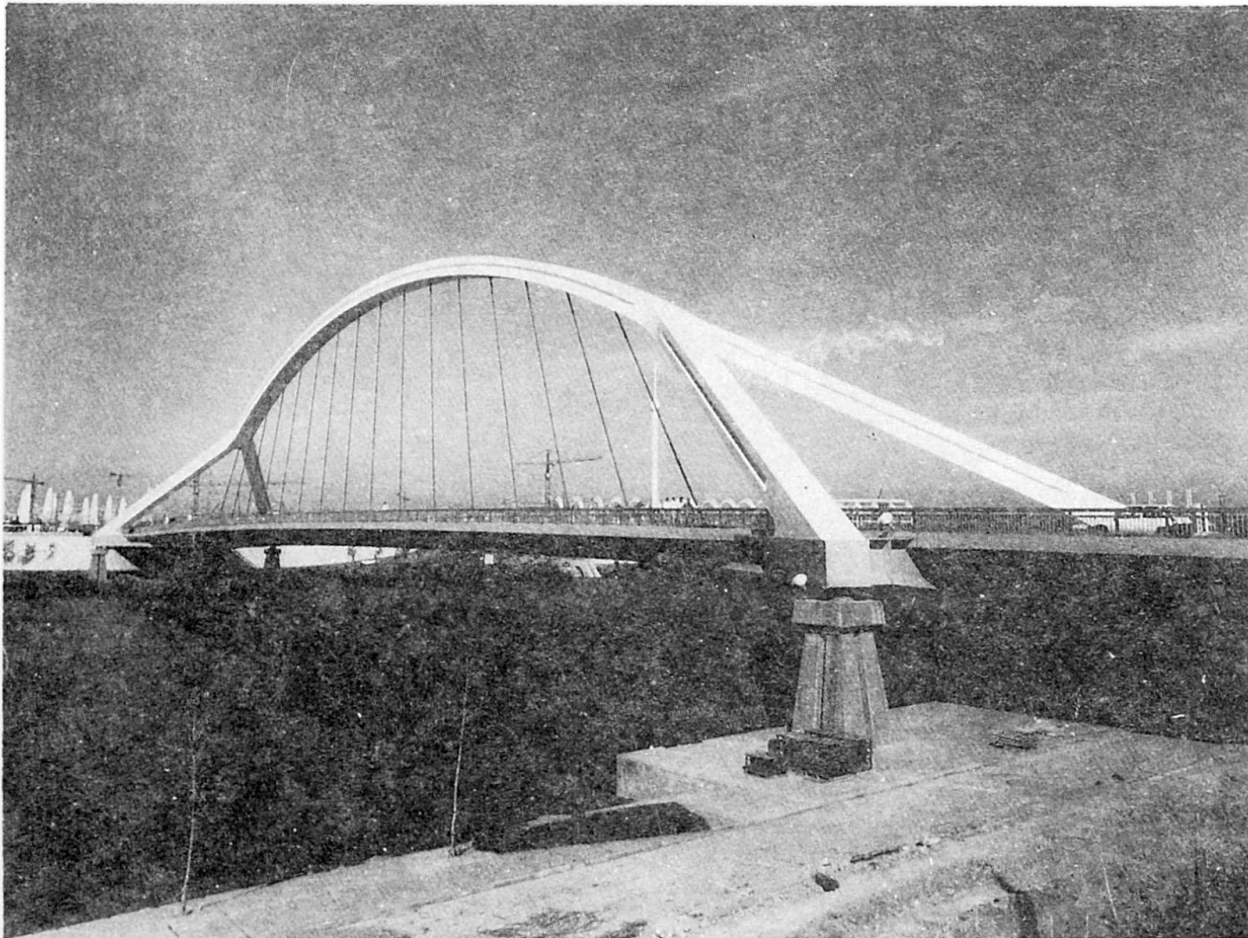

So, one may well understand the climate of scientific discovering and the pioneers atmosphere where civil engineering grown up. Either there is no difficulty to imagine the overall indifference with which old engineers looked at the architects and their decorative arts. Faced to the challenge of crossing a ravine for a new railway with a lattice iron bridge, with serious difficulties until Castigliano assessing its internal forces, who should care about shapes and proportions? Was not

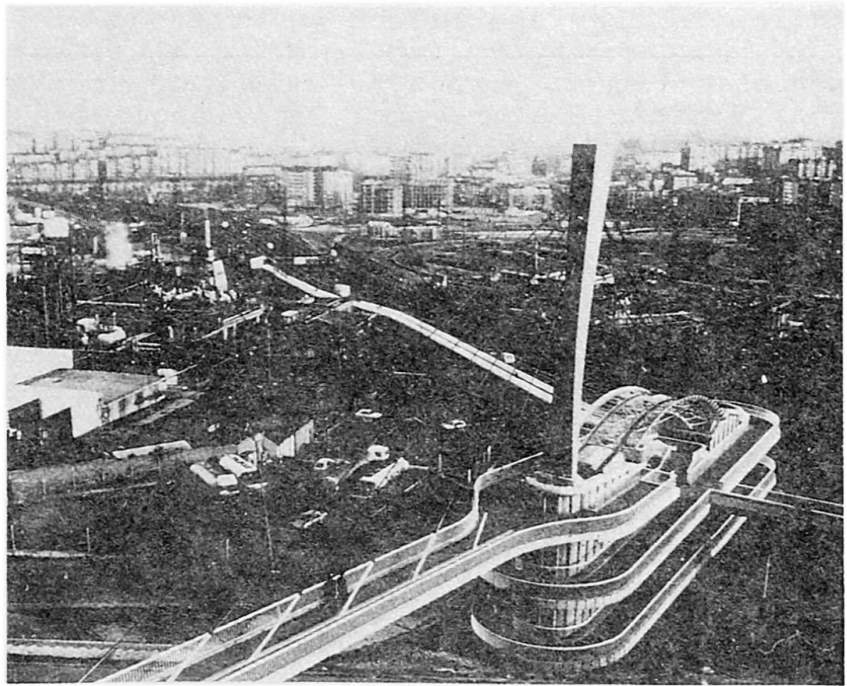

the bridge, because resisting the load of heavy trains, beautiful enough by itself? Of course, it was, and this was an accurate assesment by that time.

No longer. We face now a completely different situation. At present time, modern societies ask for something more than resisting and lasting structures. The increasing environmental consciousness leads to require that civil engineering designs are not harmful for the landscape values. But, an step further, it should lead to ask for designs that embellish by themselves their environment.

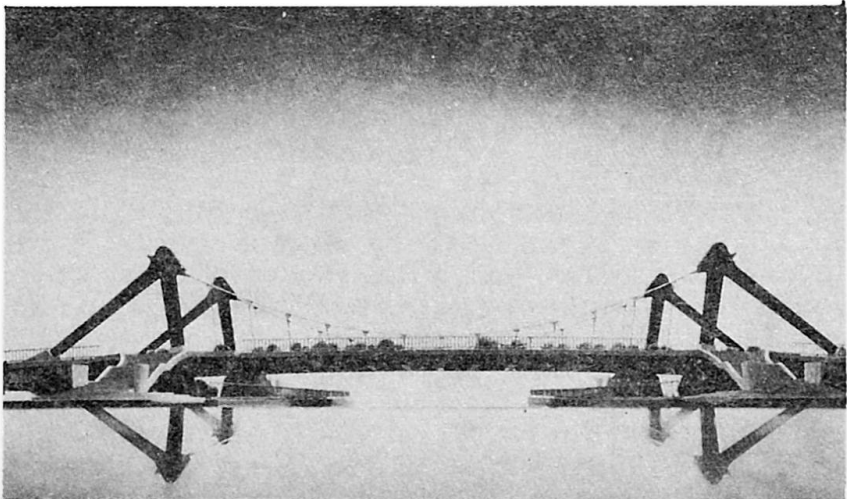

Civil engineers were and continue to be nurtured with mathematical and physical knowledge as the basis of its science. However, since its birth-day, they have been educated in a certain disregard for the values of drawing and design. If they were



engineers they should not be confused with architects, worried only with aesthetic and decorative values!. Such situation has not changed very much until now, where the same basic gap between both professions appears. Civil engineers seem in general more able to calculate and even to build than architects. But, in spite of many really achieved engineer's designs, in not few cases we actuate under high economic pressure and with not much care about the cultural and aesthetic consequences of our work. In a historic moment where a certain search for art and beauty is spreading we should not be surprised to see architects being summoned to participate in, if not to conduct, important bridge designs.

This fact may produce some anxiety among engineers. Looking in the long run, perhaps it should be good for us to think about the following points:

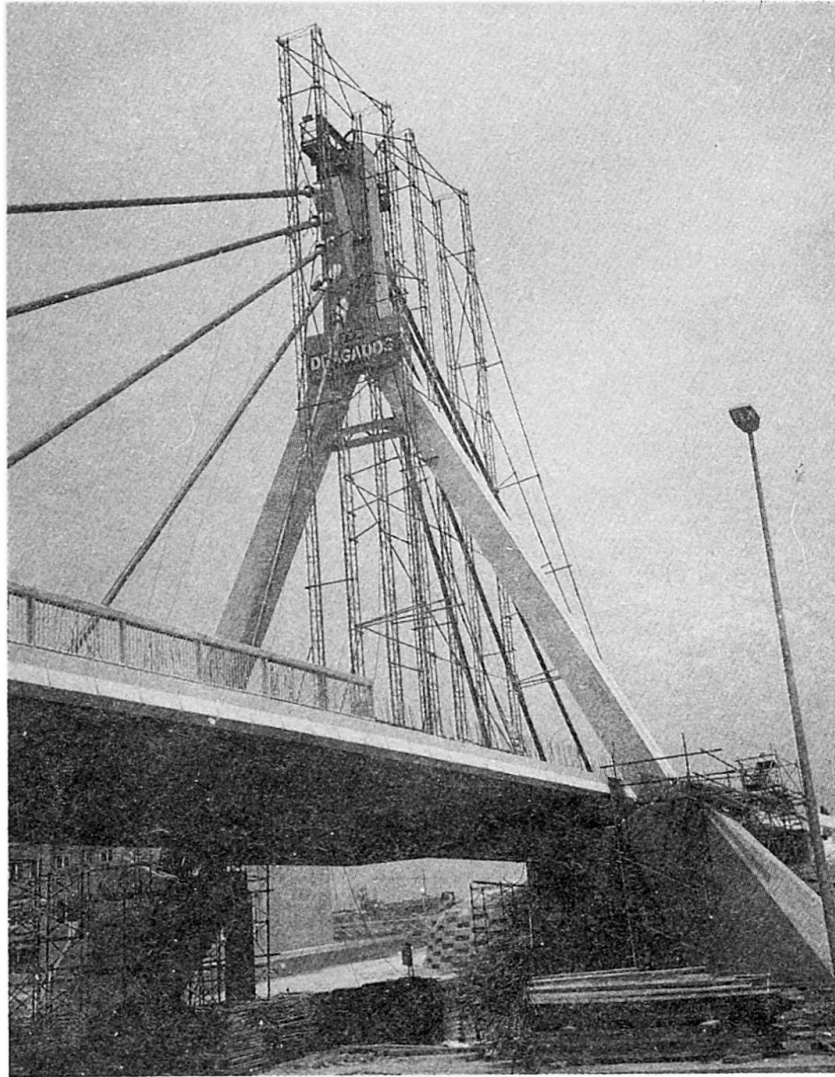

a).- The civil engineer should adopt a more open attitude towards cultural values, beauty and art. He should understand that aesthetic values are going to become functional in the sense that beauty is increasingly becoming one of the functions that a bridge must perform. A function, we think, as necessary in the near future as its resistance or durability.

b).- The aesthetic of an engineer's design should never be based on decoration. We should stress the importante, even ethical, that things appear to be what they really are. So, as the engineer job consists in knowing in depth the physical behaviour of the structural materials, he is best prepared to design shapes that fit the best the adressed problem. We should avoid to feed the "look" culture, where anything may find social appraisal if its external aspect is nice or spectacular, however its internal lack of real values.



c).- The aesthetic values of an engineering work will always be grounded on the best external expression of a good internal design. We think that one must always flee from artificial decorations, that are those that do not arise from the essence of the construction. But, at the same time, we must try to found our work on a basic order, chosen in such a way that the functional requirements are satisfied, but which, in a nearly automatic mode, will allow us to develop rhythms, proportions and relations that, since Palladio (architect and engineer), we know constitute the basis of the very idea of beauty in a construction.

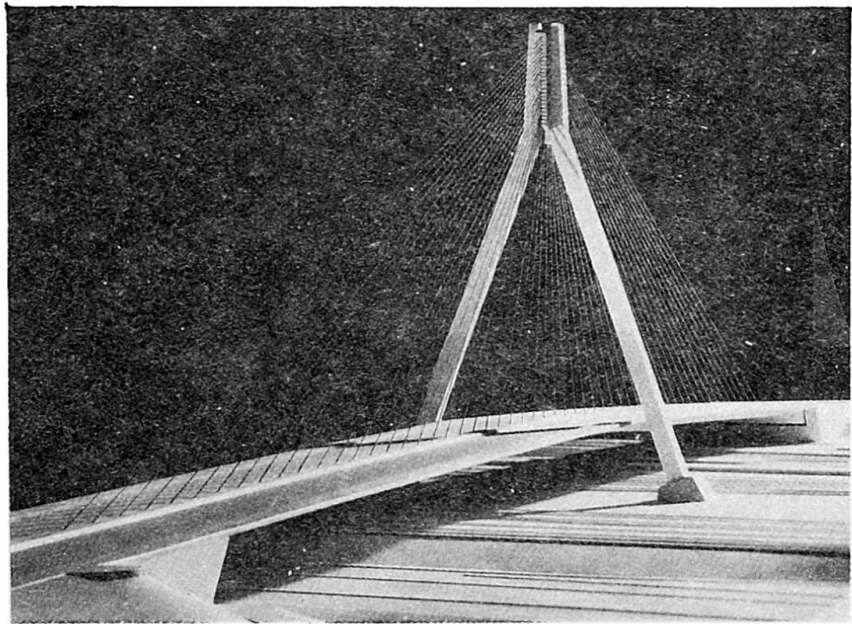
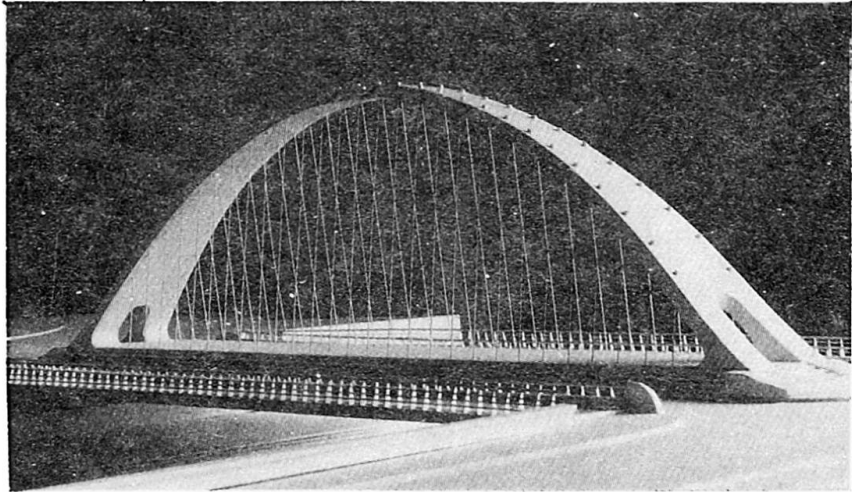

Principles like "less is more" and "form follows function", expressed by great architects with an engineer's mind, are to be strictly followed as a guarantee against errors of quitting the permanent engineering values.

d).- Of course, the basic engineering skills should be maintained. But we think that mathematics and poetry are well compatible. Further, the understanding of the performance of a structure is the only ground for achieving a good external expression of its values. Similarly, the engineer that allows his poetic impulses to arise is in the best position for materializing them. Even, through some mysterious cross-fertilization, the resistant feeling may insufflate poetical sense and the creative tension may lead to a more clear vision of the resistant phenomenon, offering solutions that otherwise perhaps would not appear in the engineer's mind.

e).- We are convinced that this is the right time to look for a more integral education program for the engineering students. Where, inspired in the architects education, Strength of Materials is learnt not over shapeless beams but rather working on beautiful volumes, whose beauty is partly derived from its good adecua-





tion to the resistant problem. Where the cultural and aesthetic values are present from the beginning and where the students are told that we look for the the stress and strains of the material but relating them in a permanent way with the quality of these shapes, as adequate to such a resistant performance. This is perhaps the right time to end with the rather artificial division between architects and engineers, arisen in 1750.

Of course, this is not an easy task: Being educated as good engineer and, at the same time, as a nearly architect. Neither it was for Perronet to decide to narrow his bridge piers or for Navier to find the neutral fiber of a cross section. Probably we are faced again with a big challenge: Putting up an educative system with such clear objectives is perhaps the Castigliano theorem to be solved by the engineers profession at the end of this century.

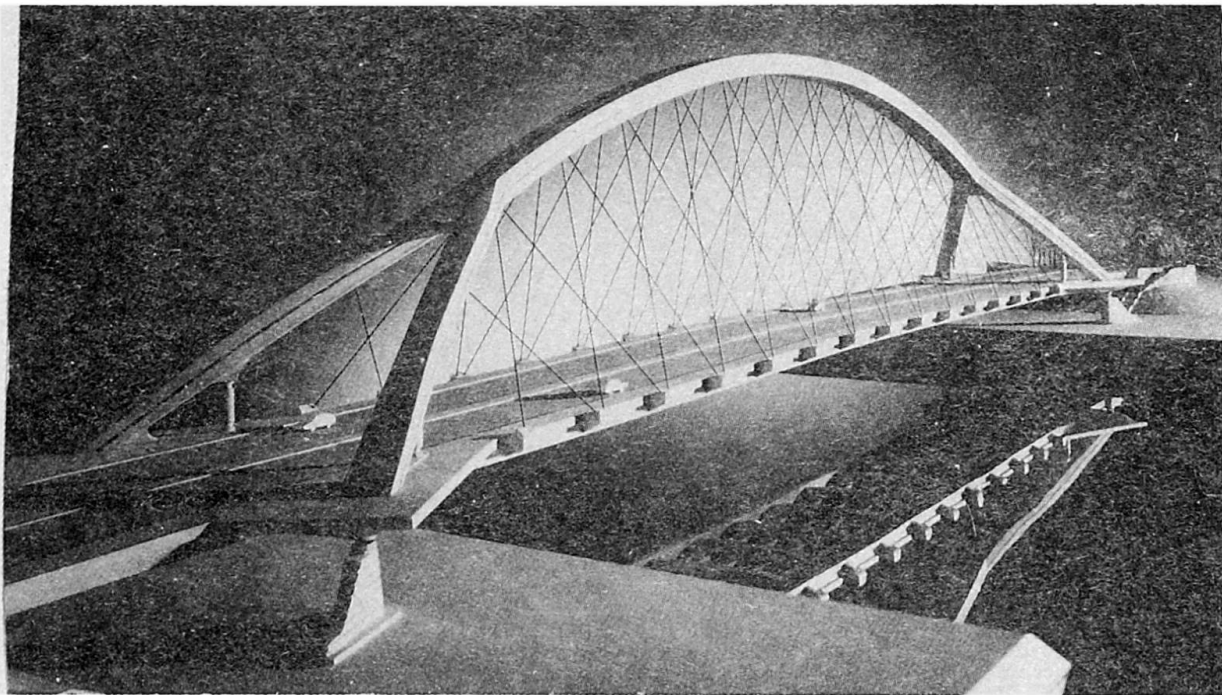

Photos included in this paper are bridges designed by APIA XXI in the last four years, in different Spanish cities:

(1): Barqueta steel bow-string bridge over Guadalquivir river, 168 m span, at Sevilla. Owner: EXPO'92. Contractor: AUXINI-ENSIDESA.

(2): Cruces concrete structure and cable-stayed footbridge, in Bilbao. Owner: Vizcaya Council. Contractor: EKONE.

(3): Model of Lago suspended bridge over the Channel of EXPO'92, Sevilla. Deck in composite construction. Contractor: AUXINI.

(4): Concrete cable-stayed bridge built in Valencia. Main span: 65 ms. Owner: SEPES. Contractor: DRAGADOS.

(5): Model of Oblatas concrete arch bridge, with 50 m span, in Pamplona. Owner. Pamplona City Council.

(6): Model of stayed steel-concrete bridge at Zaragoza: Two equal spans of each 168 meters. Owner: Zaragoza City Council.

(7): Model of tied arch concrete bridge over Ebro river, at Zaragoza. Main span: 216 ms. Owner: Zaragoza City Council.

## Development of Containment Structures in India

Développement des structures de confinement en Inde

Entwicklung des Containmentbaus in Indien

### **C.R. ALIMCHANDANI**

Chairman & Man. Dir  
STUP Consult. Ltd.  
Bombay, India



### **S.G. JOGLEKAR**

Princ. Consult.  
STUP Consult. Ltd  
Bombay, India



### **N.N. KULKARNI**

Reg. Proj. Dir & Advisor  
Nuclear Power Corp.  
Bombay, India



### **M.M. TILAK**

Chief Engineer  
Nuclear Power Corp.  
Bombay, India.

### **SUMMARY**

Starting with the introduction of prestressed concrete for the containment structures in 1963, and the concept of double containment in 1967, Indian Containment Designs continued to incorporate many innovative ideas also developing the Indian prestressing industry in this process. These developments are traced in this article.

### **RÉSUMÉ**

Après avoir introduit en 1963 le béton précontraint pour les structures de confinement et en 1967 le concept du double confinement, les projets de confinement pratiqués en Inde se sont sans cesse enrichis d'idées innovatrices, permettant ainsi le développement de l'industrie indienne de la précontrainte. Cet article retrace les progrès successifs de ce secteur de la construction.

### **ZUSAMMENFASSUNG**

Seit der Einführung von Spannbeton für den Containmentbau 1963, und des Konzepts des Doppel-Containments 1967 hat "Indian Containment Designs" fortgeföhren viele Neuerungsideoen aufzugreifen, indem die indische Vorpännindustrie auf diese Weise entwickelt wird. Diese Entwicklungen sind im Artikel skizziert.



## 1. EARLY OPTION FOR NUCLEAR POWER

After becoming independent in 1947, India launched itself on a programme of planned development whose objective was the creation of economic emancipation of its poverty afflicted millions and the creation of a technologically advanced and self-reliant society. Availability of assured and cheap Energy sources was of vital importance. While taking stock of its own natural resources it became abundantly clear to the Indian planners that the most viable long term solution to energy needs can be provided only by the atomic energy and for development of this resource, self-reliance and co-operation with like minded international community was the only path. With this aim the Indian Nuclear Power Projects programme was launched with active co-operation between the newly established Dept. of Atomic Energy (DAE) and the Canadian Government. Thus in 1963, India's second 2 x 235 MWe power project was taken up for construction at Rajasthan (RAPP-1 & 2) with Canadian design Using Pressurised Heavy Water (PHWR) System.

## 2. CONTAINMENT OF RAPP - 1 & 2

It was also the beginning of the awareness of safety aspects. The concept of containing the radioactive by-products not only during the normal operations but also in the extremely unlikely event of accidental release of the same from power reactors by providing the suitable containment building became an established safety measure. The Canadian design of 235 MWe containment consisted of 1.2 m thick, 40 m I.D. R.C.C. cylindrical enclosure capped by a hemispherical dome in structural steel. In addition a cylindrical R.C.C. wall of 30 cm thickness was required to be constructed around the dome to provide radiation shielding (Ref. fig.1).

The DAE engineers, however, considered that the construction of steel dome was costly and not suitable for using local resources since it involved shipping from Canada pre-bent plates of 50 mm thickness and field welding the same followed by testing with radiography. A search was made for an alternative solution. By then, two containments of experimental reactors had been constructed in France using prestressed concrete. The know-how of French experts was available through their Indian associates. The DAE engineers took a far sighted decision to use the prestressed concrete dome to replace both the steel dome and concrete shielding, thereby reducing the cost and using fully indigenous construction technology. India thus became the second country in the world to use prestressed concrete for the containments.

The success of this joint venture paved the way for future applications and developments which ran in parallel and at times ahead of those taking place

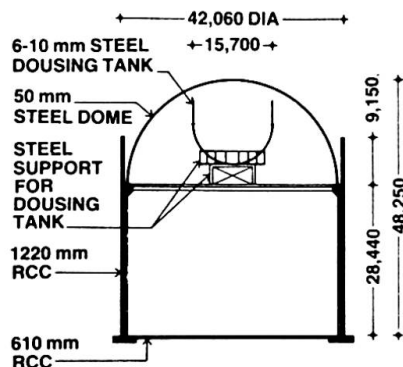

**Fig.1** RAPP Dome - Original proposal in Steel

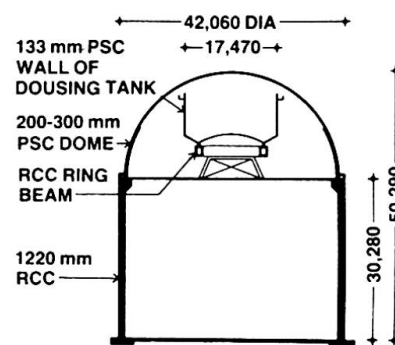

**Fig.2** RAPP Dome - As-built-in P.S.C.



elsewhere introducing in this process many innovative design concepts. The prestressing industry in India, which was only a decade old, also got impetus to develop and manufacture in the country the advanced prestressing systems of larger and larger capacities as the demand from the containment designers grew.

The original RAPP dome as conceived and as finally constructed are illustrated in fig. 1 & 2 respectively. The hemispherical dome is prestressed using meridional and ring cables upto an angle of 27.5 Deg. and by an orthogonal grid for portion above this. The meridional cables also anchor the dome to the R.C. Wall. This project used 12 dia. 7mm wire system of Freyssinet.

### 3. MADRAS ATOMIC POWER PROJECT (MAPP)

#### 3.1 Introduction of Double Containment Philosophy

Three years later for the next project at MAPP many changes in the ancillary systems of the reactor were made in the process of indigenisation of the technology. The dousing tank of RAPP was replaced by the pressure suppression pool at the bottom. This changed the shape and volume of the containment resulting in higher pressures and temperatures as compared to RAPP. Also at the time of starting the construction a policy decision was taken not to put full reliance on the cooling effect of suppression pool and to design the containment for even higher pressures and temperature effects on the basis of "dry-containment". The design pressure of MAPP Containment was taken as 1.44 kg/sq.cm. gauge as compared to 0.7 kg/sq.cm. of RAPP. At the same time, with the satisfactory experience of RAPP dome, the entire containment including the cylindrical wall and dome were decided to be constructed using prestressed concrete. Structurally, a 610 cms. thickness of wall was adequate for resisting the design loads. However, for providing full shielding from radioactivity increased thickness of material was needed. An ingenious solution was developed introducing in this process for the first time the concept of double containment which was to develop further in future containments (fig.3). A masonry wall constructed in reinforced random rubble masonry (fig.4) with thickness of 710 mm was proposed as a second wall surrounding the prestressed concrete wall, leaving an annular gap of 1000 mm. The masonry wall is designed to perform many functions. Apart from providing radiation shielding to the exterior it provides a weather shield to the inner P.S.C. Wall and also protects the same from impact of external missiles. In addition it created the annular volume into which the leakage from the inner P.S.C. Containment could be trapped. Provisions were made in the design to start pumping of the contaminated radioactive air from the annulus and filtering the same through scrubbers before releasing the same to atmosphere through specially built stack. Since in this operation of creating a small vacuum in the annulus the

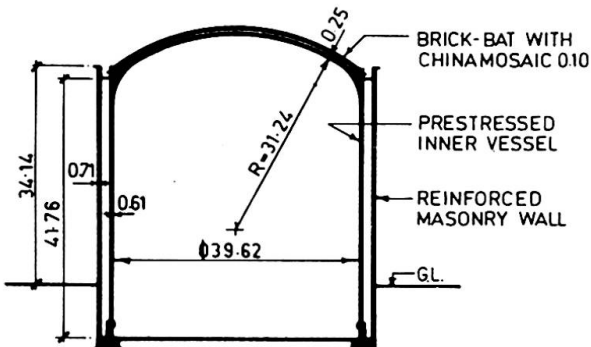

Fig.3 Double Containment of MAPP

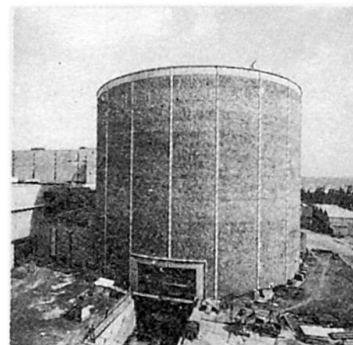

Fig.4 MAPP - Masonry Wall & B.O.P. opening.





net flow of air through the masonry wall is from outside to inside, the system presented a theoretically zero net-radioactive-leakage through the containment. This was perhaps the most significant contribution of MAPP to the containment design philosophy.

### 3.2 Requirement of Large Break-out-Panel

Additional demands were made by the developing reactor technology on the ingenuity of the civil designs in specifying the requirement of large re-openable rectangular 'Break-Out-Panel' of the size of 10m x 8 m. This was an additional requirement over and above the air lock entry of 3.2 m x 3.0 m size normally needed for the operational reasons. The normally adopted solution of providing openable steel hatch would have required massive local thickening and reinforcement and would have superimposed predominantly bending effects on the cylindrical shell structure otherwise ideally suitable as a prestressed concrete pressure vessel. To avoid this problem a section of the cylindrical wall of the 10 m x 8 m size was designed as an independent panel which is not cast monolithically with the rest of the cylinder but made structurally an integral part of the same by establishing at the boundaries of the panel the same state of membrane stresses as existing in the surrounding wall portion. Flat jacks placed within the thickness of the wall were used to create this balanced state of stresses. The horizontal ring cables and vertical cables were re-threaded passing through this portion as if the cut did not exist. This system avoided all local bending effects enabling the cylinder to behave as a shell structure. This panel can be re-opened by removing the prestressing cables and the flat jacks. For full details of this scheme reference is made to Vol. 1 of FIP Congress of 1986.

### 3.3 Provision of Rock Anchors

With good massive and impervious rock available as foundation strata, the PSC Wall was resting on a nominally thick RCC annular ring foundation. The weight of the wall and the dome is not adequate to resist the uplift caused by the pressure for which purpose flexible prestressed rock anchors have been used.

For one of the two reactor buildings the foundation rock presented unforeseen problems in certain zones and the system of rock anchors had to be replaced with massive ring raft foundation anchoring the containment wall to the same and making use of the mass of the ring raft for resisting uplift.

This project uses 12 dia 8mm wire system of prestressing manufactured indigenously by Freyssinet.

## 4. NARORA ATOMIC POWER PROJECT (NAPP) AND KAKRAPAR PROJECT

The next project at Narora is located on bank of river Ganges in north India with foundations on alluvial sandy strata requiring a full RCC raft as a common foundation for the containment and the internal building. Also this site is located in the zone of high seismicity where the S.S.E. Earthquake of 0.3 g ground acceleration was considered for the design.

Further changes in the internal ancillary systems were made changing the shape of the containment for this series of projects. The main steam generators were brought partially out of the inner containment and placed on the containment slab. The main idea was to keep only the primary heat exchange circuits involving radioactive inventory inside the containment and to bring out the secondary steam circuits outside. The arrangement is shown in fig. 5.

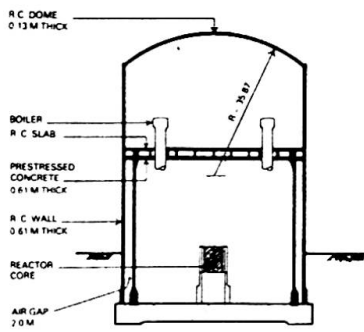

Fig.5 NAPP Containment

This unusual arrangement put the following unusual demands on the design of the containment slab.

- Spanning over 40 m on containment wall the slab had to carry the enormous accident pressure of 14.4 t/sq.m. in bending unlike the spherical dome which is a naturally suited shape for resisting the pressure load by membrane action.

- The large requirement of sectional modulus combined with the need to reduce the adverse effects caused by the combination of high seismicity and large mass of the slab called for the construction of a cellular slab which has a more favourable strength to mass ratio.

- The functional requirement demanded that there should be no relative movement between the boiler and inner structure, but at the same time, containment slab should be able to deflect independently. To overcome this problem specially designed spring supports were engineered supporting boilers on the containment slab.

- The large number of embedded parts on the top slab made it impossible to put prestressing cables in any practical way in the top slab thus making RCC action mandatory for resisting upward pressures. At the same time the inner barrier (lower slab) had to be prestressed to keep it leak-tight.

A composite cellular slab with prestressed bottom slab and RCC webs and top slab was evolved. The ingenious design of this slab meeting all the above demands is described elsewhere in the documents of this congress and hence reference is made to the same for details. (Ref. Poster Session)

The concept of double containment introduced in MAPP was further refined in this design. The outer containment was provided as a complete enclosure over the inner containment unlike MAPP where dome portion does not have an out containment. The material was changed to reinforced concrete which is a more leak-tight material of universal availability unlike stone masonry which used locally available specialist skill around MAPP area. Incidentally the extra leak-tightness of RCC also reduced the load on pumps which create the vacuum in the annular space requiring smaller capacity pumps. Unlike MAPP, this system in NAPP is proposed to be kept permanently under negative pressure.

The large break-out panel of MAPP was no longer required to be of re-openable type and hence could be closed after moving in of heavy components. The location of this temporary opening called closure panel has been merged with that of the Airlock. However, the use of flat jacks to prestress the newly concreted portion of the panel and to establish the desired stress patterns in this area has been continued. Four such reactors at two sites have been constructed and tested with this design, the second site being at Kakrapar.

For this project a new Freyssinet system of Prestressing was developed and tested indigenously before acceptance. This system uses 12 nos. of 13mm strands and steel wedges similar to 'K' series anchorages of Freyssinet but using the modified S-6 jacks of their 12 T 13 system. This system has now become well established in the Indian construction scene.



## 5. RAJASTHAN 3 & 4 AND KAIGA STATIONS

The next series of 235 MWe containments at these sites look more like their western cousins used for PWR series by the French. While retaining the double containment philosophy, the standardised design has a common foundation raft for Inner and outer containment and internal building with provision of stressing gallery inside the body of the raft. The walls are constructed monolithically with the raft and have segmental domes over them. The outer containment and dome are in RCC and the inner system in PSC. The typical cross section is seen in fig.6.

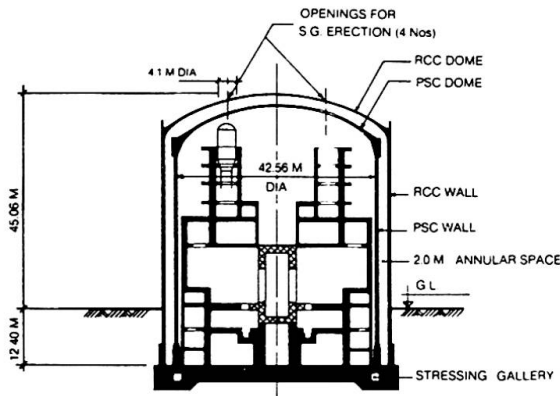

Fig.6 Section of Kaiga Containment

The requirement of large breakout panel has been completely eliminated. However, the size of Airlock has gone in for upward revision. The concept of providing openings in the inner prestressed dome for erection and subsequent removal of boilers is an extension of similar concept introduced in Kakrapar design for RCC outer dome at Kakrapar site.

For the Kaiga Site, the seismic effects are more severe causing uplift of raft of more than 60%. To avoid this, use of rock anchors has

been made. These are provided through the annular space between the inner and outer wall anchoring the raft to the base rock. For these projects, prestressing systems of larger capacity using 19 strands of 13mm indigenously manufactured and tested by DAE has to pass the acceptance tests been used. For additional details of this design reference is made to the presentation in poster session of this congress.

## 6. FUTURE DEVELOPMENTS - 500 MWe SERIES

The basic design concepts which are on the same lines as that of Kaiga & RAPP 3 & 4 have been adopted for this new generation of higher unit capacity reactors. However, the search for better, cheaper and faster solutions consistent with the stringent requirements of safety has continued. It is proposed to introduce, the systems of slipforming of walls to minimise the construction joints and to maximise the speed. This is ofcourse subject to the economic and time viability. Also it is proposed to use a fully integrated steel dome as a shuttering for PSC dome thus enabling early release of lower floors for erection of equipment.

## 7. CONCLUSION

The developments in the field of containment structures in India which started in 1963 are typical examples of the state-of-the-art in this field. Following the introduction of prestress congress the concept of double containment and many other innovative ideas have been developed while meeting difficult challenges. These structures represent one of the most successful adoption of advanced design and construction technologies of the west by a developing country using locally available skills and materials giving in this process impetus to indigenous prestressing industry.

## New Horizons with Arapree Prestressed Concrete

Nouvelles perspectives du béton précontraint d'Arapree

Neue Aussichten mit Arapree — Spannbeton

### Arie GERRITSE

Civil Engineer  
Hollandsche Beton Groep  
Rijswijk, The Netherlands



Arie Gerritse, born in 1929 graduated in Civil Engineering at Rotterdam Technical College, the Netherlands. He is a senior staff member of the R&D department of Hollandsche Beton Groep (HBG)

### Rolf-Dieter BOTTCHER

Civil Engineer  
Akzo nv  
Wuppertal, Germany



Rolf Dieter Böttcher born in 1955 obtained his Civil Engineering degree at the Technical University of Braunschweig in 1982. He is project manager in the field of application of fibre reinforced materials in Civil Engineering.

### Martin EGAS

Civil Engineer  
Hollandsche Beton Groep  
Rijswijk, The Netherlands



Martin Egas born in 1963 obtained his Civil Engineering degree at the University of Technology Delft, the Netherlands in 1988. He is working as a research engineer at the R&D department of HBG.

## SUMMARY

Arapree is a tendon composed of parallel aramide fibres in an epoxy resin. Since they are non-corrosive and non-magnetic they create new applications for concrete. Examples — like the substitution of tropical hardwood — are given in this paper. New materials bring about less common material behaviour, so much attention has to be given to design approach. For the purpose of this paper the damage warning behaviour of fully elastic materials like Arapree is discussed.

## RÉSUMÉ

Arapree est un câble composé de fibres aramidées parallèles noyées dans une résine époxyde. Etant donné qu'ils sont noncorrosifs et nonmagnétiques ils donnent lieu à de nouvelles applications pour le béton. Des exemples — comme la substitution du bois tropical — sont énumérés dans cet article. Les nouveaux matériaux ayant des comportements moins connus que les matériaux courants, demandent pour cela une attention particulière dans leur étude. Le but de cette note est d'étudier le comportement de la ductilité ("warning behaviour") de matériaux entièrement élastiques comme l'Arapree.

## ZUSAMMENFASSUNG

Arapree ist ein aus parallelen Aramid-Fasern und einem Epoxidharz aufgebautes Zugelement. Da es korrosionsfrei und elektromagnetisch neutral ist, eröffnen sich ihm neue Anwendungsmöglichkeiten. Beispiele dafür — wie der Ersatz von tropischem Hartholz — werden in diesem Aufsatz vorgestellt. Dabei müssen die speziellen Eigenschaften dieser neuen Materialien beim Entwurf berücksichtigt werden. Besondere Aufmerksamkeit findet daher in diesem Beitrag die Schadensvorankündigung von Konstruktionen, die mit rein elastischen Materialien wie Arapree bewehrt sind.





## 1. INTRODUCTION

High tech developments nowadays are well known in the electronic and aerospace industries. In civil engineering however, innovative processes are going on too. For example the development of high tensile prestressing elements, made out of man made fibres.

A range of developments in bars and tendons consisting of continuous high strength fibres, usually embedded in a polymeric matrix, is aiming at structural application in concrete. This concerns at the moment glass, aramid and carbon fibres.

Their strength capacities are in the range of prestressing steels. Several other material characteristics however differ considerably from those of the well-known steels (like Young's modulus, creep, relaxation, stress rupture, behaviour in aggressive environments etc.) These different characteristics are to be considered thoroughly in design and design criteria.

This paper deals specifically with the effects and challenges of applications of Arapree prestressed concrete [1].

Due to the non-corrosivity and other superior properties, these tendons create new applications for concrete. For example (very) thin walled structures which reduce the mass of the structure while still maintaining the advantages of the material concrete.

Arapree tendons are composed of aramid fibres (brandname Twaron) embedded in epoxy and have the following main properties:

- \* high fibre-strength, up to 3000 N/mm<sup>2</sup> (related to fibre-cross-section)
- \* excellent fatigue behaviour
- \* non-corrosive, both in strong alkaline and carbonated concrete
- \* resistant to aggressive environments as acids, bases and salts (e.g. chlorides and sulphates)
- \* insensitivity to electro-magnetic currents.
- \* Young's modulus of the fibres is 125,000 N/mm<sup>2</sup>

A practical overview of material properties and recent applications of Arapree is given in [1] and [2].

Because of the relatively low Young's modulus it is apparently more appropriate to use Arapree as a prestressing material.

The capacities of Arapree shape however possibilities to more than only spectacular thin and non-corrosive concrete. Also applications in fields where - up to now - no alternatives are available. Thus uses where e.g. tropical hardwood, chemically treated wood, steel structures etc. are common.

So new horizons are disclosed with Arapree prestressed concrete not only by the structures themselves but also by environmental improvements, such as saving the tropical forest.

## 2. WARNING BEHAVIOUR

Since important characteristics of this type of material differ from those we are acquainted to, the safety approach has to be reconsidered. Firstly a life span comparable to what is commonly expected of concrete structures (say 100 years) must be ensured. So reliable estimates have to be made on the long term behaviour in the (alkaline) concrete matrix [2].

The next important safety requirement is that there has to be a warning behaviour long before an eventual failure due to overloading occurs. Brittle failure has to be avoided.

Both concrete and Arapree have no plastic zone. That suggests that in case of overloading the structure can collapse suddenly without warning.

A composition of two brittle materials however does not necessarily lead to a new brittle material. Such a composite structure can also show a sufficient ductility and a so called "warning behaviour".



The ductility of a prestressed concrete element is influenced - independent of type of tendons - by:

- the residual strain capacity of the tendons after prestressing
- location and quantity of the tendons
- elastic modulus (Young's modulus) of the tendons
- bond behaviour of the tendons.

From [3] and [4] we can learn that with a careful design the residual strain and the Young's modulus have great influence on deflection. And contrary to other suggestions, [3] and [4] also state that the bond behaviour of tendons has only a restricted influence on the deflection. Good bond with short transfer and anchor lengths will cause a lot of cracks with small crack widths and short crack distances. While worse bond causes less cracks but larger crack widths.

In figure 1 the deflection is calculated for a balcony slab prestressed with Arapree in comparison with a slab prestressed with steel strands. Both slabs have the same moment of rupture and location of the tendons. The calculation is checked by a test at the University of Technology Eindhoven. The calculation and the test results showed good resemblance.

The residual strain capacity of Arapree after pretensioning is 1.2% (prestressed at 50% of the ultimate strength) and that of the prestressing steel 2.9% (prestressed at 60% :  $(3.5 - 0.6 * 1860/200.000 = 2.94\%)$ ).

Although the Arapree slab has a lower rotation capacity (see fig.2) the deflection at the centre is greater.

The lower residual strain is "compensated" by the lower Young's Modulus, as a result of which the slab deflects more at the range where it is cracked. Thus to obtain a high deflection, criteria have to be stated not only on the ratio  $M_u/M_{cr}$  ( $M_u$  = ultimate moment ;  $M_{cr}$  = cracking moment) but also on the ratio  $\kappa_u/\kappa_{cr}$  ( $\kappa_u$  = ultimate rotation,  $\kappa_{cr}$  = rotation at the moment of cracking).

If the prestressing force of Arapree ( $P_o$ ) is limited to 50% to 60% of the ultimate strength ( $P_u$ ) the requirements on  $\kappa_u/\kappa_{cr}$  and  $M_u/M_{cr}$  are met [3]. By coincidence  $P_o/P_u \leq 0.55$  is the same criterium that has been proposed to be used in relation to durability and long term safeguarding of the strength of Arapree [2].

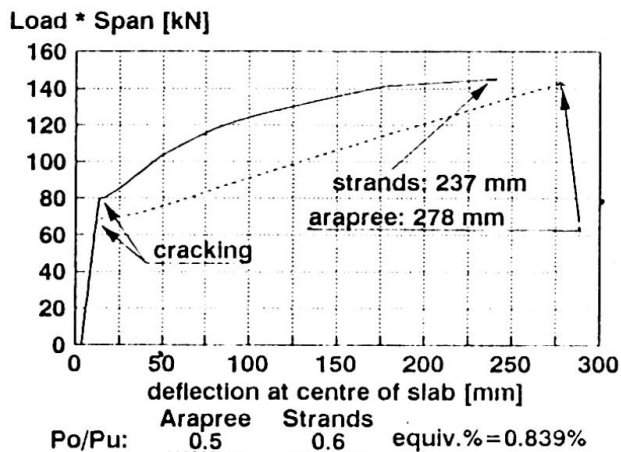

fig. 1: deflection at mid span of a slab prestressed with steel and with Arapree

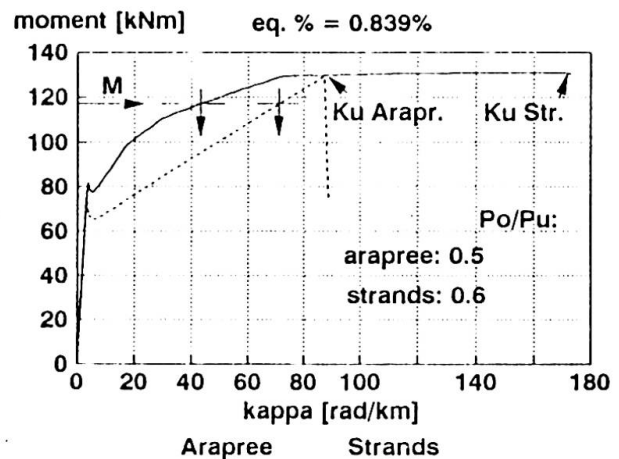

fig. 2: moment-rotation curves of the slabs of fig.1

The afore mentioned leads to the following conclusions:

- it is possible to design structural components composed of brittle materials in such a way that the components show satisfactory flexibility and rotation capacity in bending.
- in order to achieve that goal it is necessary to define requirements on the constituent materials as well as on the design of the composed structural component.



## 3. DESIGN

### 3.1 Design data for prestressing

Taking into account:

- a life-span of ca. 100 years
- stress losses due to creep, relaxation and shrinkage
- stress rupture, a phenomenon very important for all high strength fibres
- residual strength
- warning behaviour

The following design values can be determined for Arapree:

- initial stress in Aramid fibre after release  $\sigma_{apo} \leq 0,55 f_{atk} = 1540 \text{ N/mm}^2$   
( $f_{atk}$  : characteristic short term strength =  $2800 \text{ N/mm}^2$ )
- total relaxation of Arapree (after 100 years) may be taken as 15% in dry environment and 20% in wet environment.

### 3.2 Application areas

Since artificial fibres as aramid are non-corrosive, market prospects are good for applications where total costs of a steel reinforced construction exceed those of an Arapree reinforced construction due to corrosion. Maintenance costs are also to be considered!

Therefore the main fields of applications of Arapree are (very) thin elements and structures in highly aggressive environments. Other interesting fields are non-magnetic or non-conductive elements and structures exposed to severe fatigue loads.

### 3.3 Environmental protection

A good example of a promising application area is the substitution of tropical hardwood; the use of which is under discussion nowadays.

#### 3.3.1 **fish-ladders**

In the Netherlands a hydro-electric power station has been built in the river Meuse. To allow fish to by-pass the station, a fish ladder was constructed near the power station.

The fish ladder has been built up out of 24 weirs. Each weir consists of concrete piles with concrete shutters in between. Additional to a weir, a foot-bridge by which the winch of a sluice can be reached, has been constructed (fig. 3,4 and 5).

All these elements are made out of concrete prestressed with Arapree. Concrete elements are made in colours and have the required surface structure. The shutters have a thickness of only 35 mm. Such thin walled elements with a weight of just 18 kg are easy to handle and have been installed using light equipment.

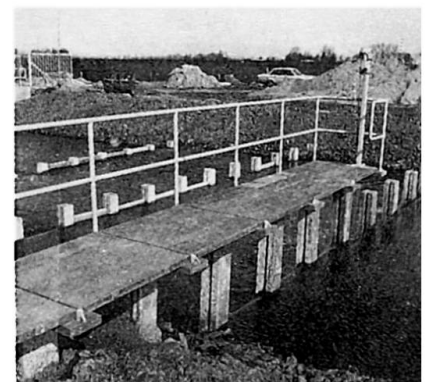
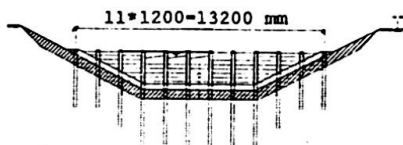

fig. 3: View of a weir    fig. 4: piles and shutters    fig. 5: foot-bridge

One of the conditions was that the water stream in the passage could be changed at any time and any place. That required a flexible system with shutters that could easily be handled by hand.

Technically a thickness of 35 mm is not the minimum. Smaller thicknesses (e.g. 25 mm with a weight of 13 kg) can be considered. However to avoid steel secondary reinforcement the tensile strength of the concrete must be quite high to overcome splitting forces due to stress transfer.

3.3.2 **Bank protection**

Bank protection with a soil-retaining height from 1.0 to 3.0 m consists normally of wooden shutter piles or of wooden sheet walls.

A feasibility study [6] made clear that concrete elements prestressed with Arapree can substitute wooden bank protection. In this study was taken into account dead load, ground parameters and costs. Construction costs were excluded but they are obviously lower for thin elements. For retaining heights of 6.0 m and more conventional reinforced concrete is more attractive because then required thickness (ca. 120 mm) becomes that high that reduction of the cross-section thanks to less cover is no longer significant.

Three pile wall types are chosen from nine designs and further analysed. The following systems are considered the best alternative:

- up to 1.0 m: a system of piles and shutters (fig. 6).
- from 1.0 m: a pile wall (fig 7).
- from 3.0 m: a pile wall of profiled elements (fig. 8).

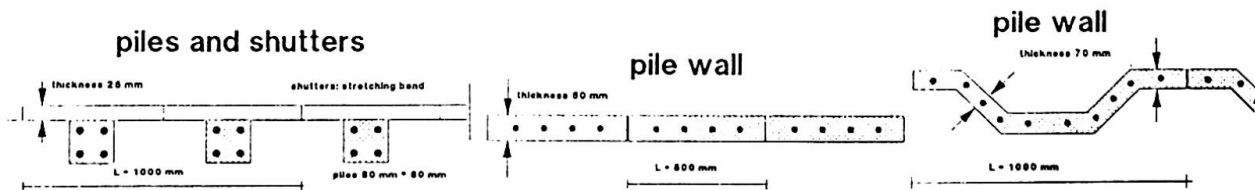

fig. 6: heights up to 1 m      fig 7: heights 1 - 3 m      fig 8: heights 3 - 6 m

The price optimum of Arapree concrete elements is reached at a height of ca.3.0 m. At that height the elements are even cheaper than wooden protection.

3.4 Creative design

Since the first pilot project in 1988 a lot of experience is acquired with regard to design and performance of Arapree prestressed concrete structures. This experience proved that making a good design in Arapree requires a new way of thinking.

Arapree is a material with its own advantages and disadvantages. Although not all problems are solved yet, spectacular structures are possible if one is prepared to leave the beaten paths.

An excellent example is the design of a tunnel daylight screen. The screen is aimed to protect drivers against direct sunshine. It consists of 600 Arapree prestressed concrete elements of 250 mm width, 90 mm height and a span of 12.8 meters. The elements are slightly curved with a rise of 1.0 m and therefore fully self supporting in spite of their very small dimensions (fig. 9). Elements prestressed with steel would be too thick due to corrosion protection and therefore not meet the conditions on minimum and maximum sunlight. This daylight screen is an alternative to the originally planned extruded aluminium lammellae supported by a beamgrid of coated steel.

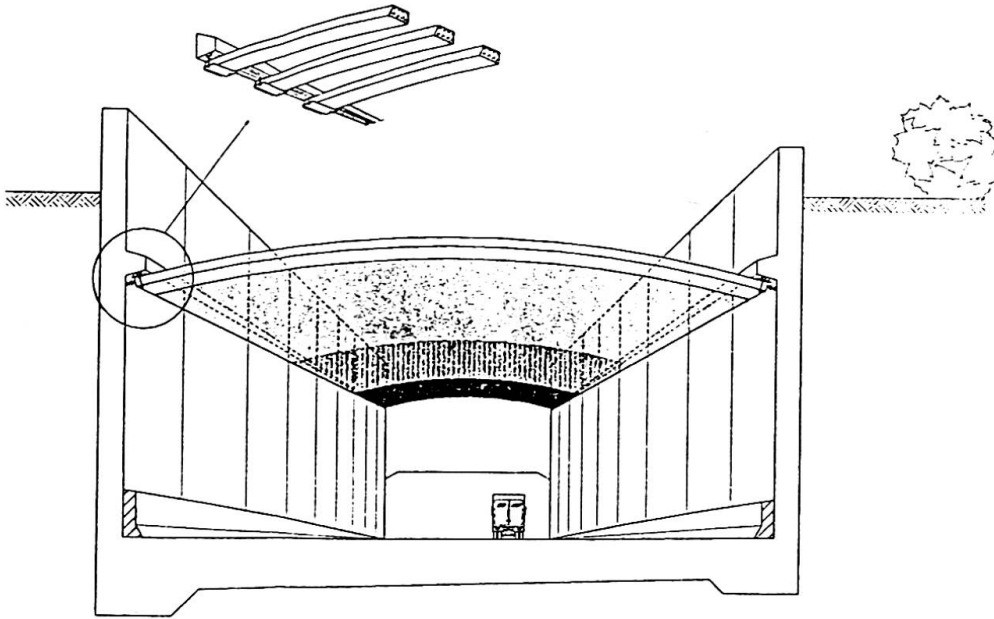

fig. 9: Perspective view of a tunnel daylight screen

More information on creative designs and examples of structures in Arapree is given at the poster presentation.

#### 4. CONCLUSIONS

To realise structures in new materials a reliable safety concept is essential. For Arapree a safety concept has been developed in which a life-span of 100 years is ensured.

Warning behaviour is taken into account in this philosophy.

If the prestressing force of Arapree is limited to ca. 55% of the characteristic short term strength, the deflection - at mid span - will be equal to the deflection of a comparable steel prestressed structure.

For more than four years now experience with the design and performance of Arapree prestressed elements has been gained. Attractive application areas are thin walled elements and structures in highly aggressive environments. Also chances in the substitution of tropical hardwood and chemically treated wood by concrete becomes attractive. New markets are opened for concrete as is shown by the design of a tunnel daylight screen.

#### 5. REFERENCES

- [1] Gerritse, A; Arapree, a non-metallic tendon. Contribution to the conference on: "Durable reinforcement for aggressive environment" Luton, 22 november 1990.
- [2] Gerritse, A; Werner, J; Egas, M.; Developing design requirements for non-metallic tendons. IABSE congress, september 1990, Brussels.
- [3] de Sitter, W.R.; Gerritse, A.; Elastico plastic design of composite structural members with brittle materials. Symposium dedicated to prof. Rostasy of the TU Braunschweig BRD, May 1991. (Not officially published yet)
- [4] Dolan, Ch.W.; Developments in non-metallic prestressing tendons. PCI Journal september -october 1990
- [5] van Beek, R.J.; Feasibility study: concrete sheet walls prestressed with Arapree for bank protection. Graduation thesis, TU Delft, May 1991 (in Dutch)



## Dickwandige Profile in Stahlkonstruktionen

Thick-Walled Sections in Steel Structures

Profilés à âme épaisse dans les ouvrages métalliques

### Ómer BUCAK

Dr.-Ing.  
Univ. Karlsruhe  
Karlsruhe, Deutschland



Ómer Bucak, geboren 1947, studierte an der Universität Karlsruhe Bauingenieurwesen, Promotion über das "Ermüdungsverhalten von Hohlprofilknoten". Er arbeitet auf dem Gebiet des Stahl- und Anlagenbaues, des Ermüdungsverhaltens von Stahl und Aluminium als auch deren Verbindungen.

### Friedrich MANG

Prof. Dr.-Ing.  
Univ. Karlsruhe  
Karlsruhe, Deutschland



Friedrich Mang, geboren 1934, promovierte an der Universität (TH) Karlsruhe als Bauingenieur. Er habilitierte auf dem Gebiet "Stahl- und Leichtmetallbau". Er arbeitet auf den Gebieten des Stahl- und Anlagenbaues, der Werkstoffermüdung und deren Verbindungen.

### ZUSAMMENFASSUNG

Der vorliegende Bericht gibt die Ergebnisse der statischen und dynamischen Untersuchungen an dickwandigen Walzprofilen wieder. Die Ergebnisse von Bauteilen mit Stumpfstoßen mit und ohne Schweißfehler sowie solche mit Stegaussteifungen werden mitgeteilt und die Ergebnisse mit denen aus hochfesten Stählen verglichen.

### SUMMARY

This paper describes static and fatigue investigations on butt welded rolled thick-walled sections as well as full-scale tests on specimens with web attachments. Information is given on the results of structural members with and without weld defects and those with web stiffeners and the results are compared with those from high-strength steels.

### RÉSUMÉ

Le présent rapport donne les résultats des recherches statiques et dynamiques sur les profilés laminés à âme épaisse. Les résultats obtenus sur les éléments de structure joint bout à bout avec et sans défauts de soudage, ainsi que ceux se rapportant aux nervures raidies, sont fournis et comparés à ceux obtenus sur les aciers à haute résistance.



### 1. GENERAL

The reason for the application of thick-walled steel sections and predominantly rolled sections is that effective dimensions and bigger cross section areas can be economically produced through large pre-fabrication in the rolling mill. The first rollings in series from wrought iron were carried out in about 1800 to 1820 as rail rollings.

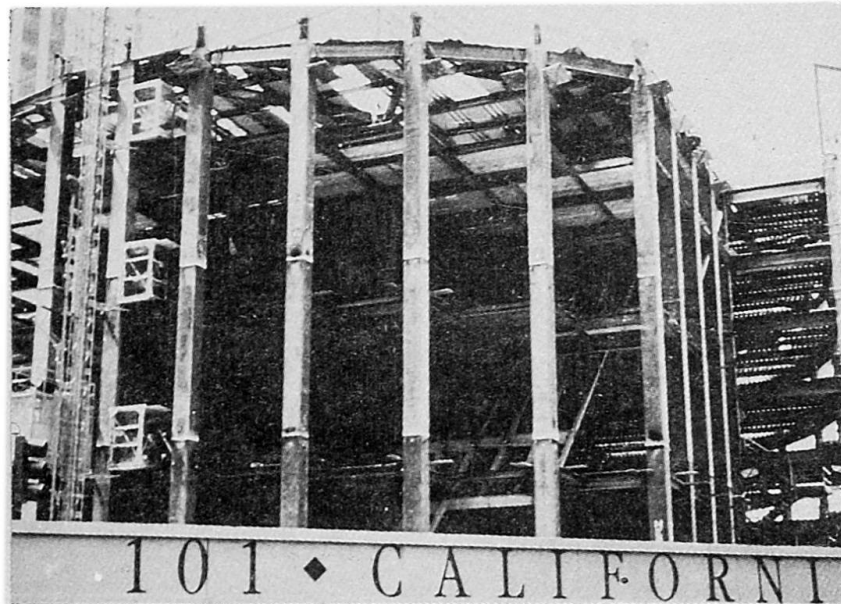

Fig. 1 High-rise building in the USA

The first usable sections regarding steel construction developed as L- sections in 1831. In 1845 welded steel pipes and in 1849 H-sections (double T-sections) had been rolled. Nowadays, large I-sections with flange thicknesses of 125 mm and a total height of 1200 mm can be rolled without any problems. Even for the high-strength qualities such as StE 460, a steel quality can be gained by additional alloy elements. Modern steel production methods such as QST (Quenching and Self-Tempering) qualities of ARBED-Luxembourg facilitate higher yield limits and tensile strengths at lower values for the carbon equivalent.

This is advantageous when welding such thick-walled sections. Up to now, the main field of application was the high building construction (fig. 1). In the last years these sections have been also used as girders subject to bending in high building construction, since the overall height could be saved. The application of large size, especially of thick-walled steel structural members necessitates the knowledge of various material properties determining the bearing behavior. The modern methods in steel production and especially the rolling technology have eliminated or largely limited the disadvantageous characteristics as they have been originally attached to classified rolled sections [1, 2, 3].

### 2. COMPRESSION MEMBERS MADE OF THICK-WALLED ROLLED SECTIONS (COLUMNS)

Main test series

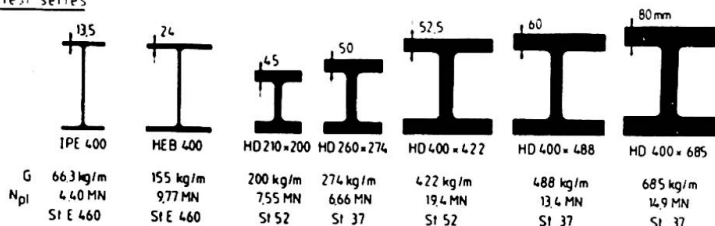

Large size rolled sections have already passed their test for the application as compression members. For the classification in buckling stress curves of Eurocode 3 [1] corresponding investigations have been made in Karlsruhe with the sections (flange thicknesses up to 122 mm) illustrated in fig. 2 [2].

Additional tests

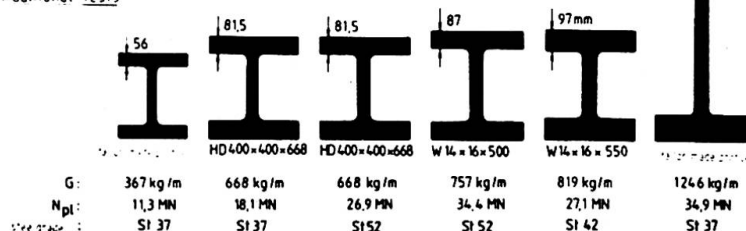

Up to then it was necessary to classify the rolled sections with flange thicknesses of about 40 mm in the European buckling stress curves "d".

Fig. 2 Rolled sections for investigations on buckling made in Karlsruhe

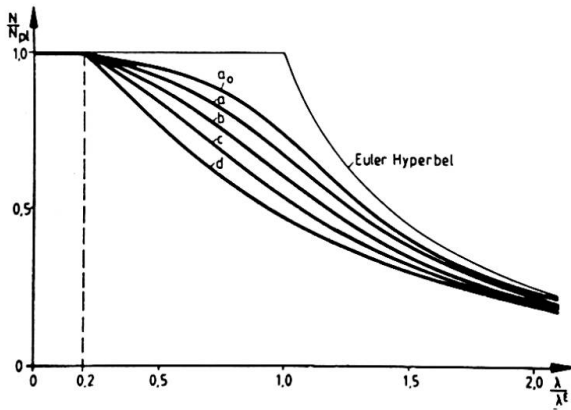

Fig. 3 shows the test specimen with a flange thickness of 97 mm and a length of 8,0 m in the 50 MN-testing machine of the Versuchsanstalt für Stahl, Holz und Steine.

The new classification into the buckling stress curves of Eurocode 3 are shown in fig. 4 with the arrangement that only beginning from a flange thickness of 100 mm a classification in curve d and in the flange thickness range between 40 and 100 mm; curve b and c are important.

cross section	buckling above axis	buckling curve
rolled H-sections		
$t \leq 40 \text{ mm}$	y - y z - z	a ( $a_0$ ) b (a)
 $\frac{h}{b} > 1,2$ $40 \text{ mm} < t < 100 \text{ mm}$	y - y z - z	b (a) c (b)
	$t \leq 100 \text{ mm}$	y - y z - z
$t > 100 \text{ mm}$	y - y z - z	d d

[1] For steel grades StE 460 and StE 690 the more favourable buckling curves given in brackets can be used, but with flange thicknesses smaller than 40 mm.

Fig. 4 Classification of the rolled sections according to Eurocode 3, edition Nov 1989 [1]

In addition to the application as columns or compression members, the use of thick-walled sections can also be useful as bending members or beams or chord members of girders.

Fig. 3 Test specimen with a flange thickness of 97 mm and a length of 8.0 m in the 50 MN-testing machine of the University of Karlsruhe

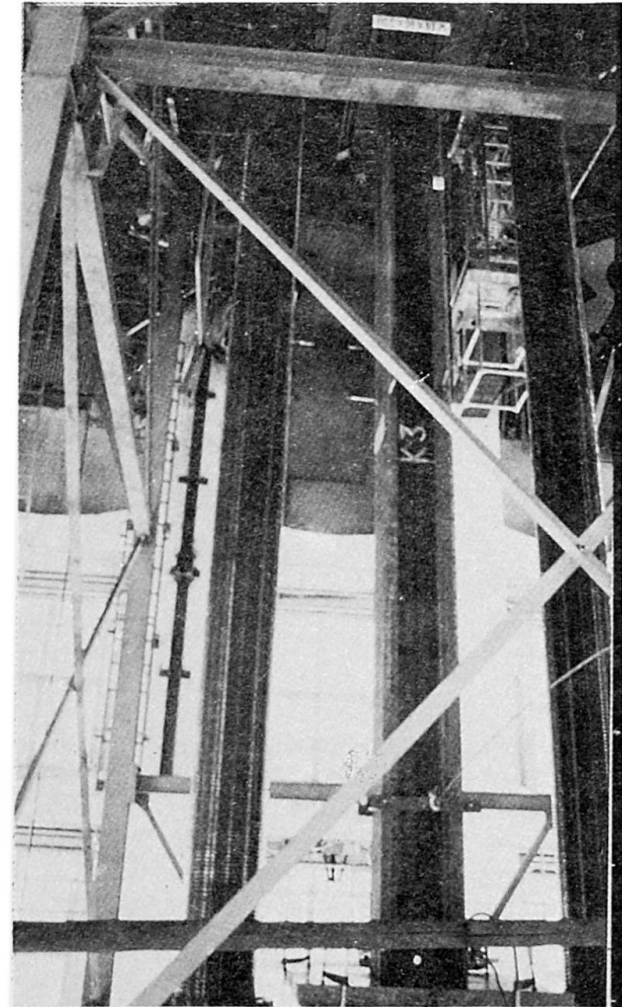

### 3. BEAMS MADE OF THICK-WALLED ROLLED SECTIONS

#### 3.1 Beams with butt welded connections

Since the welding technology has been applied, their application for thick-walled rolling products was regarded as critical, if at all, they were only permitted under limiting conditions. When introducing the old German standard DIN 4100 [4], the reasons for this have been indicated as follows:

- areas of segregation that cannot be excluded, especially in the area of the neck, transition from flange to web
- combination of residual stresses regarding rolling and welding,
- non satisfying possibilities of non-destructive tests.





These restrictions are presently not valid or can rather be excluded, such as for example areas of segregation on rolled section (due to modern fabrication methods).

Siteshop welding lower flange with hole

(Girders are already fixed and cannot be turned)

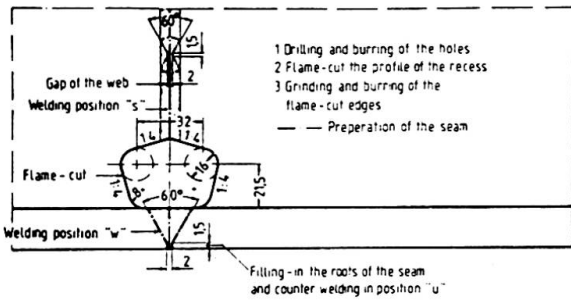

With joints of the site shop, conditions should be avoided in predicaments, if possible. For this reason a welding on one side in the form of V-butt welds for flange welds is realized (figs. 5 and 6).

In contrast to this, X-butt welds can be selected for workshop conditions with the possibility of turning the beam to positions that are favorable for welding. The latter are to be classified as more favorable with regard to welding and require less deposited metal and thus, less time for welding and less heat entry.

Fig. 5 Butt welded connections with holes on beams

Workshop welding lower flange without hole

Siteshop welding lower flange without hole

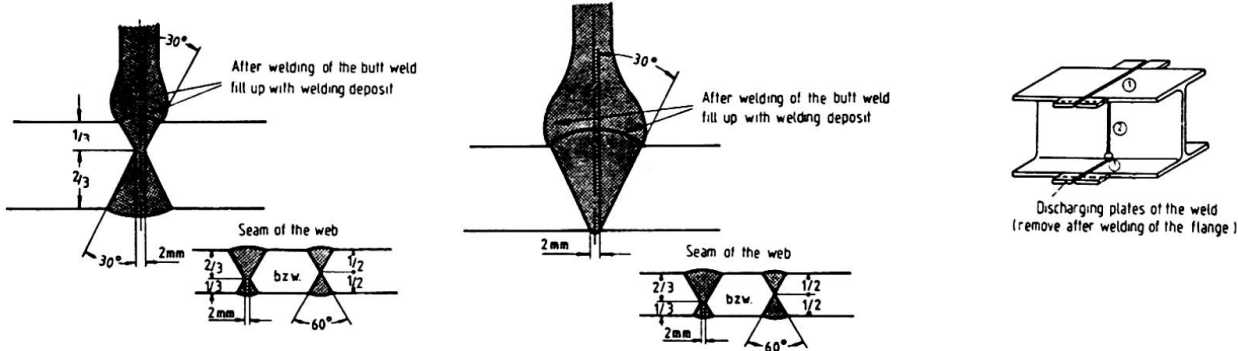
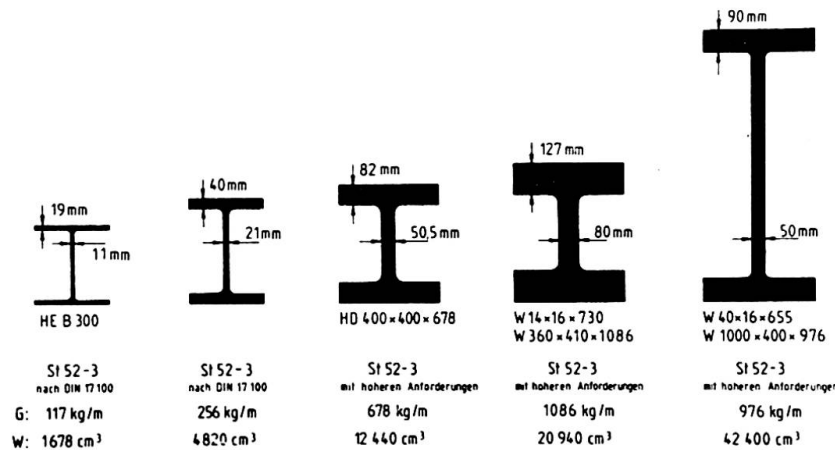

Fig. 6 Butt welded connections without holes on beams

The main test series have been carried out on the hot rolled beams HE300B and HE400M. Figures 10a and 10b show the test results of the fatigue tests separately for both design variants. Data of the test specimens produced under site shop and under workshop conditions have not been distinguished. The results of the fatigue investigations on the sections W920x420x876 with a flange thickness of 82,0 mm were entered into the same diagrams. From this it becomes evident that the test values are in a good accordance with the main test series. Test results on specimens with 80/82 mm flange thickness in QST-quality are marked with the symbols ( ) and specimens with 30 mm flange thickness ( ).



The load bearing behavior of butt welded, thick-walled beams under static and fatigue load has also been investigated in Karlsruhe. Fig. 7 shows the dimensions of the sections in the tests.

Fig. 7 Thick-walled rolled sections for bending tests

Fig. 8 shows the type of fracture after a fatigue test for a butt welded specimen with holes. The fracture starts from the outside area of the tension flange and at the same time from the hole to the web. For the design without hole, the fracture started from the outside of the tension flanges (fig. 9).

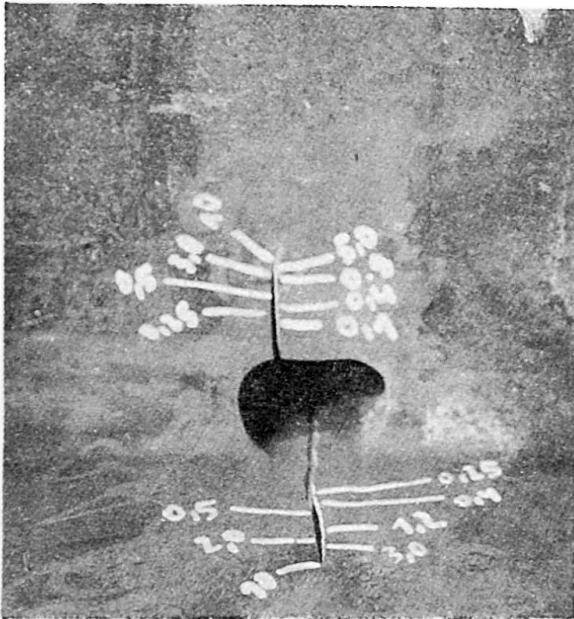

Fig. 8 Fracture of the butt welded specimens with holes

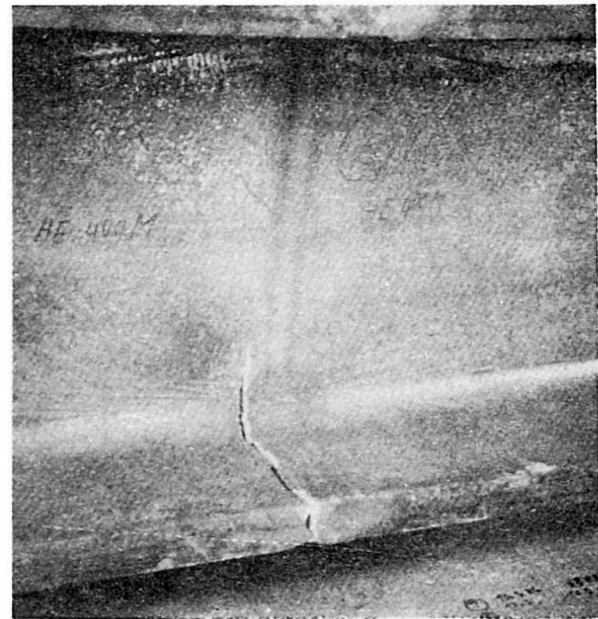

Fig. 9 Fracture of the butt welded specimens without holes

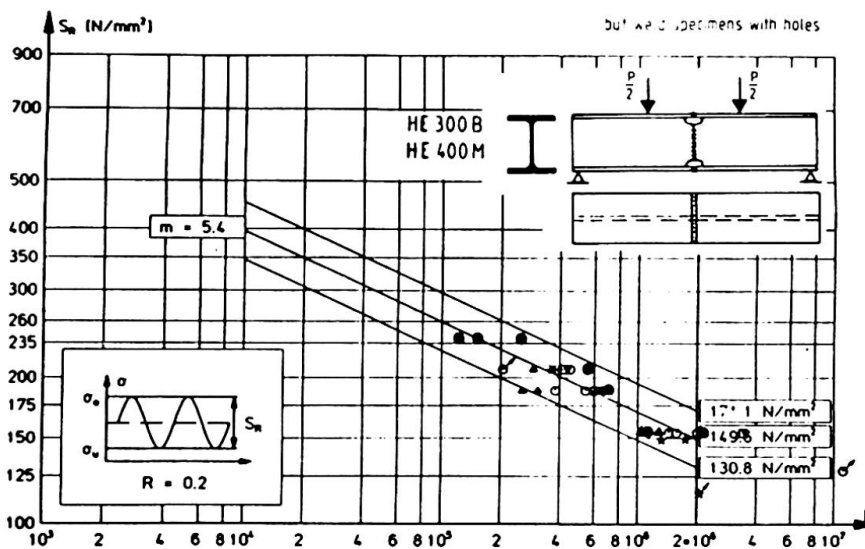

Fig. 10a Results of the fatigue tests on butt welded specimens with I-sections. Test specimens with holes.

The better position of the less notched design without holes can be seen from the categories for assessment. In this connection it has to be pointed out that the butt welds with holes result in better welding conditions and less design risks.

Some specimens showed unacceptable big failures after welding so that they normally cannot be admitted for application. Nevertheless, these specimens have been tested in order to investigate the influence of such lack of fusion on the fatigue behaviour. In figure 11, the results of the investigations are recorded comparatively to the specimens without defects.

It can be seen from this presentation (fig. 11) that the specimens with lack of fusion show bigger differences in the endurance compared to those specimens without weld defects. The slope of the S-N-line for this type of construction is lower and this resulted in the lower difference of the  $\sigma$  between the test results with and without weld defects.

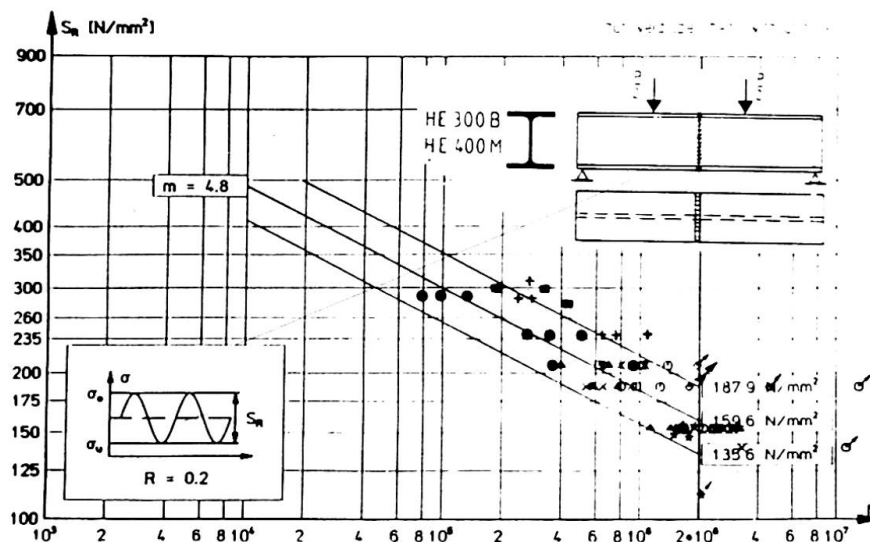

Fig. 10b Results of fatigue tests on butt welded test specimens with I-sections without hole

The fractures and load deformation diagram according to fig. 12 furnished the proof of a good, i.e. usual plastification capacity after a rapidly increased load up to the fracture. The fracture loads for various design variants do not show any significant differences.

By means of fig. 13 it is to be demonstrated that, nevertheless, risks do exist, if welding parameters are not kept carefully and brittle fractures are provoked.

The danger of brittle fracture with a wrong treatment of such thick-walled structural elements resulted in the fast development of new steel grades such as those of the QST-method

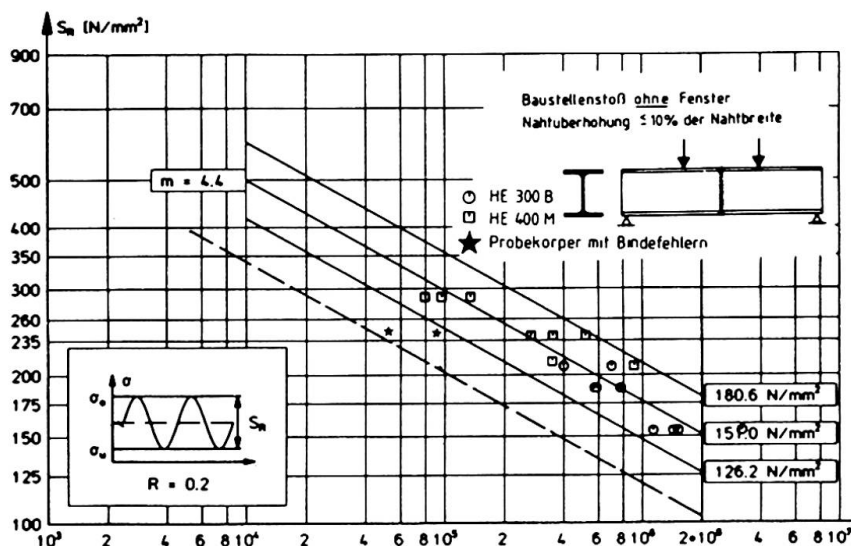

Fig. 11 Influence of lack of fusion on the fatigue strength of large-size structural members. Butt weld without hole.

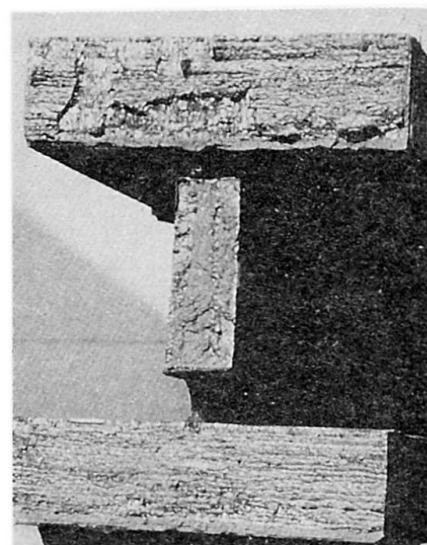

Fig. 13 Fracture and complete cross section

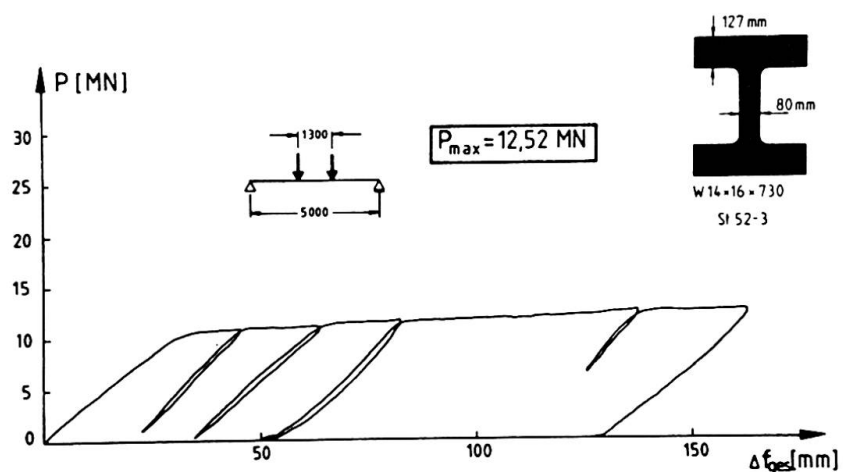

Fig. 12 Load deformation diagram for thick-walled rolled beams

#### 4. CONCLUSIONS

Following the presentation, welding of thick-walled sections can be done without any problems. The developments in the field of metallurgy, rolling methods and the possibilities of processing allowed the application of thick-walled sections in welded structures. Thus, a more favourable production of large-size structures is available.

## Joining Method for Use in Automated Building-Frame Erection

Montage automatisé pour les ossatures en portique

Automatisierte Montage von Rahmentragwerken

### **Mamoru IWATA**

Department Manager  
Nippon Steel Corporation  
Tokyo, Japan

Mamoru Iwata, born 1947, received his doctor of engineering degree at the Tokyo Institute of Technology. He is responsible for the technology development of building construction. He is a member of IABSE, AIJ, and JSCE.

### **Akira WADA**

Professor  
Tokyo Institute of Technology  
Tokyo, Japan

Akira Wada, born 1946, received his doctor of engineering degree at the Tokyo Institute of Technology. His research interest is in architectural building structures. He is a member of IABSE, AIJ, JCI, and JSCE.

### **Mitsuhiko YAZAKI**

Senior Manager  
Nippon Steel Corporation  
Tokyo, Japan

Mitsuhiko Yazaki, born 1951, received his master of engineering degree at the Tokyo Institute of Technology. He is responsible for the research and development of systematized buildings.

### **Hiroki KAWAI**

Senior Structural Engineer  
Nikken Sekkei Ltd.  
Tokyo, Japan

Hiroki Kawai, born 1938, received his master of engineering degree at the University of Waseda. He is working at Nikken Sekkei as a structural engineer. Now he is involved in the waterfront project of Tokyo bay.

### **SUMMARY**

This paper discusses a new jointing method developed as a step toward the automation of in-situ assembling of structural members at the erection stage. The use of this jointing method will not only facilitate construction automation but also make it possible to very easily remove structural members for reuse during extension, remodelling or dismantling of buildings.

### **RÉSUMÉ**

Cette étude expose une nouvelle méthode d'assemblage qui a été conçue en tant qu'étape intermédiaire vers l'automatisation d'assemblage sur places des éléments de structure pendant la phase de montage. L'utilisation de cette méthode d'assemblage facilite non seulement l'automatisation du montage, mais elle facilite aussi le démontage des éléments de structure, afin de les réemployer en cours d'agrandissement, de transformation ou de démontage des bâtiments.

### **ZUSAMMENFASSUNG**

Dieser Vortrag erörtert ein neues Gliederungsverfahren, das als eine Massnahme zur Automatisierung der Montage von Bauteilen an Ort und Stelle bei der Ausführungsstufe entwickelt wurde. Die Verwendung des Gliederungsverfahrens fördert nicht nur die Bauautomatisierung, sondern auch die sehr leichte Beseitigung der Bauteile, um sie während der Erweiterung, des Umbaus oder der Demontage von Gebäuden wiederzuverwenden.



## 1. PREFACE

Industrially advanced countries, having telecommunications technology through the use of electronics, satellites, fiber optics and other high technologies, are rapidly transforming into advanced information societies. This has helped accelerate the shift toward tertiary industries and a concentration of population in urban areas, resulting in the growth of buildings and urban facilities in both magnitude and height. Furthermore, modern urban buildings, which emerged about one hundred years ago, are on the verge of obsolescence. Yet, even at this stage, the construction industry is still unable to shake free from the restraints of conventionalism, and lags far behind other industrial sectors in productivity. With no or very little improvement foreseeable in the construction labor situation, it is becoming harder and harder for the construction industry to hire people.

In this situation, research and development primarily aimed at the improvement of productivity in construction has finally been initiated in the past several years. Specifically, R&D is addressing the introduction of new construction materials, new manufacturing and fabricating systems, construction automation, and AI in design and management. Building construction as an integrated system aided by these technologies will be a breakthrough in the present impasse in the construction industry, through the introduction of industrial efficiency.

This paper discusses a new jointing method developed as a step toward the automation of at-site assembling of structural members at the erection stage. This jointing method presupposes the automation of jointing work, as opposed to the usual practice of weld-jointing or high-tension-bolt jointing employed for steel structures.

## 2. SYSTEMATIZED BUILDING STRUCTURE

A building structure using the new jointing method is called a Systematized Building Structure (SBS). The SBS is a system for supplying general-purpose structures for medium and high-rise buildings.

Thus far, systematized building construction has been developed and utilized for housing, factory and office-building construction purposes in many fields and in many different ways. Yet, given these premises, we still propose to further address the task of developing the SBS now, for the following reasons:

- (1) The need for improvement in the construction labor situation.
- (2) Emergence of technology seeds in peripheral high technologies to facilitate and promote industrialized building construction.
- (3) The imminent need for conservation of construction materials and energy.
- (4) Social need for modernization of the construction industry and a new concept in building manufacture and construction.
- (5) The need for a system of integrating the design, manufacture, construction and maintenance of buildings, based on computerization and communications.

As a condition for organizing the SBS, the environment for construction of a building needs to be viewed within a certain hierarchy. In a sense, this hierarchization is characteristic of building construction itself. Also, in order to permit the scientific growth and development of building construction, which is an extremely complex, total system containing both metaphysical and physical problems, hierarchization is indispensable. To promote the rational progress in sophistication and self-organization in building construction, hierarchization is a very effective approach.



For the SBS we have in mind, the following hierarchy is envisaged (Fig. 1).

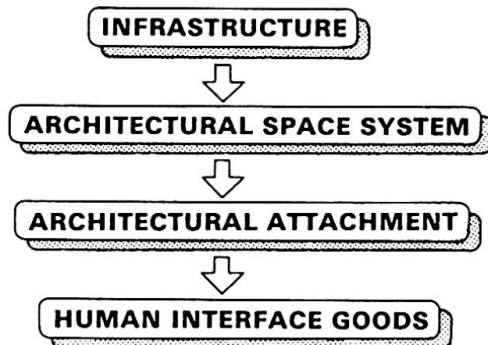

Fig. 1 Hierarchy of architecture

- (1) Infrastructure.  
Facilities which restrain an architectural space system and support economic and social activities outside the building: roads, water-purification, sewerage and energy-supply systems, and telecommunications systems.
- (2) Architectural space system.  
System to fixate architectural space: columns, beams, roofs, floors, walls, stairs and elevators.
- (3) Architectural attachment.  
Goods which do not fixate architectural space but are mounted on the architectural space system, for decoration or for improved performance of architectural space: doors, windows, curtain walls and unit equipment.

(4) Human interface goods.

Goods which directly interface with humans and support human life: furniture, lighting equipment, interior goods, AV equipment and other home electrification equipment.

In this hierarchy, with levels (1) to (4) in their order of predominance, the upper-level systems restrict lower-level systems according to prescribed rules. In the architectural space system, the SBS represents the structure.

### 3. PERFORMANCE REQUIREMENTS OF THE SBS

The required performance of the SBS is prescribed by infrastructure, which is the upper system, and by the SBS's consistency with the architectural space system as a whole, as well as by interfacing with architectural attachment. The SBS's performance is also prescribed by integrated computer control exercised over the design, manufacture, execution and maintenance or the so-called CIM (computer integrated manufacturing), which integrates CAD, CAM, CAC (computer aided construction), and CAP (computer aided planning).

In concrete terms, the SBS's performance requirements are conceived to be as follows:

- (1) To conserve energy and resources, structural components of the SBS must have long durability.
- (2) The whole architectural space system containing the SBS must be a system with sufficient flexibility vis-a-vis changes in space characteristics to match changes in functions and uses.
- (3) In order to clearly define the structural performance of the SBS, the strength, jointing performance and deformation capacity of individual structural components of the SBS must each be clearly defined and prescribed for high structural integrity.
- (4) To assure the long-time use of the SBS in terms of structural members, components must be standardized and possess interchangeability with respect to performance.
- (5) In consideration of the construction phase of the SBS, the SBS must be amenable to automation at the site.





With respect to jointing and modules, consistency of the SBS with the architectural space system as a whole is established. In other words:

- (1) The SBS is made to be suppliable separately from the architectural attachment of a lower hierarchical level by setting rules for mutual compliance by both the architectural space system as a whole and the architectural attachment.
- (2) The SBS consists of four structural elements: namely, floor, wall, column and beam.
- (3) The SBS's four structural elements each consist of members and components.
- (4) Members have configurations suited for automatic assembling at the site, with corresponding jointing methods.
- (5) Individual components are conceived as being primarily prescribed by configuration and structural characteristics and being functional in their performance when placed in any position of any building. In this respect, individual components are rendered characterless.
- (6) Material of components, despite being steel, has outstanding heat resistance and atmospheric corrosion resistance.
- (7) Components are manufactured by the production system designed for highly advanced machine work.
- (8) A systems approach is used for the SBS, taking into consideration every technological possibility and consistency at each level involving the whole structure, structural elements, members, components, and materials (Fig. 2). Also sought is structural rationality in the total flow of construction, from the design, manufacture, assembly and erection to maintenance.

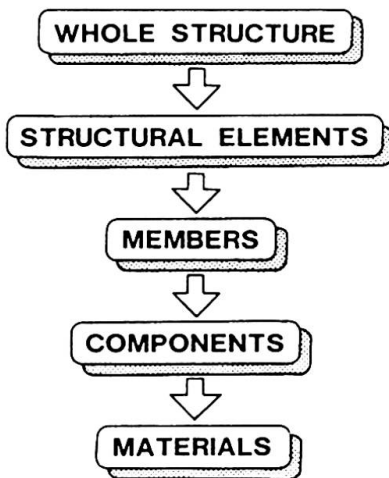

Fig. 2 Hierarchy of structure

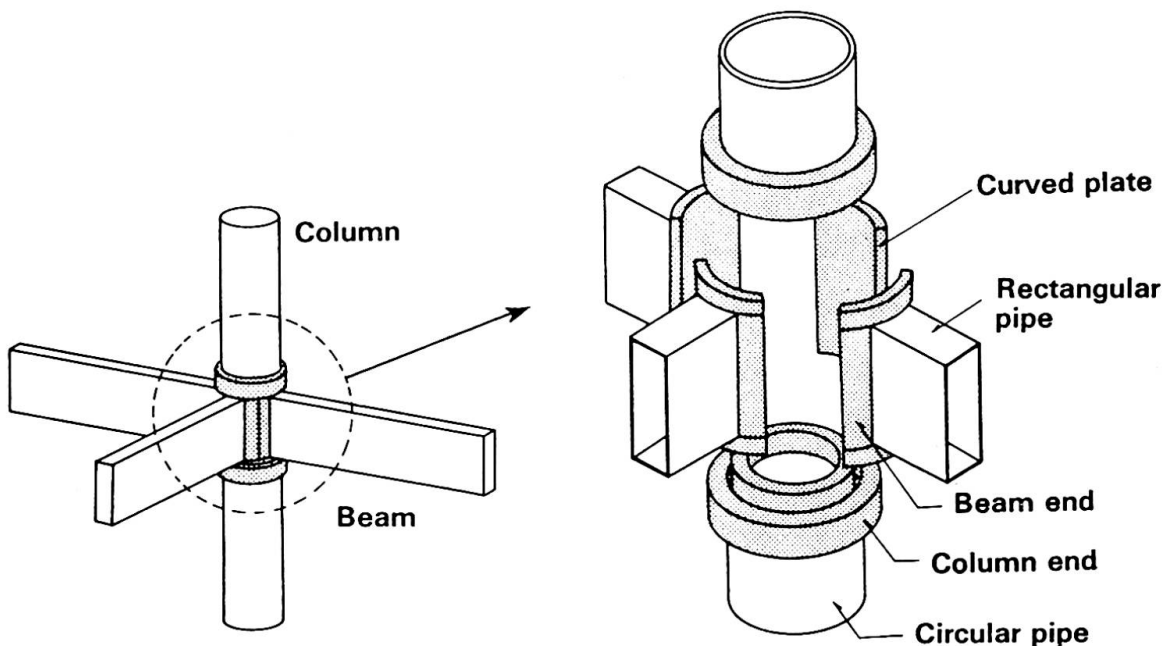

Fig. 3 Column-to-beam joint

#### 4. A NEW JOINTING METHOD FOR THE SBS

The SBS at the present stage looks like a traditional Japanese timber structure. This SBS is a prefabricated structural system consisting of a column and beam, and uses a new jointing method instead of a conventional bolting or welding connection.

A column-to-beam joint is shown in Fig. 3. This is a rigid joint.

- (1) A column member is made by factory-welding a grooved ring, called the column end, to each end of a circular pipe.
- (2) A beam member is made by factory-welding a quartered cylindrical segment tapered at the top and bottom, called the beam end, to each end of a rectangular pipe.
- (3) At the site, the beam ends are inserted into the groove of the column end. The pressing down of the column end of the subsequent story column fixes the beam ends.
- (4) In the directions where there are no beams, quartered cylindrical segments tapered at the top and bottom, called the curved plate, are inserted.
- (5) In order to secure structural integrity of the joint, the column ends are further tightened using hydraulic jacks.

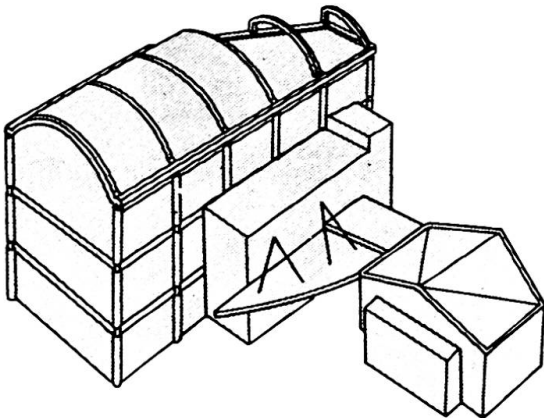

Fig. 4 An example of construction

These ingenious devices are designed to transfer axial forces, bending moment and shearing force at the column-to-beam joints. Column ends, beam ends and curved plates are forged and machined for greater dimensional accuracy.

#### 5. AN EXAMPLE OF CONSTRUCTION

The new jointing method has been applied to the actual construction of a building having three stories and one basement, with a span of 7.8m and a ridge span of 18m (3.6m x 5m span), as shown in Fig. 4.

Installation and jointing are shown in Figs. 5 and 6.

Fig. 7 shows the whole structure.

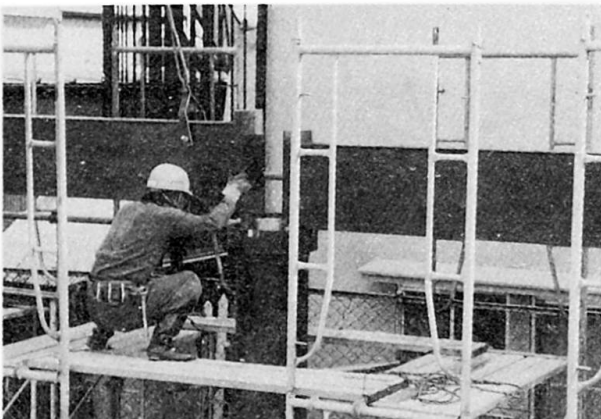

Fig. 5 Beam member

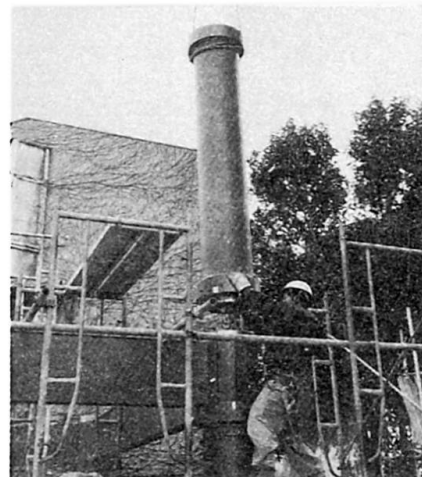

Fig. 6 Column member

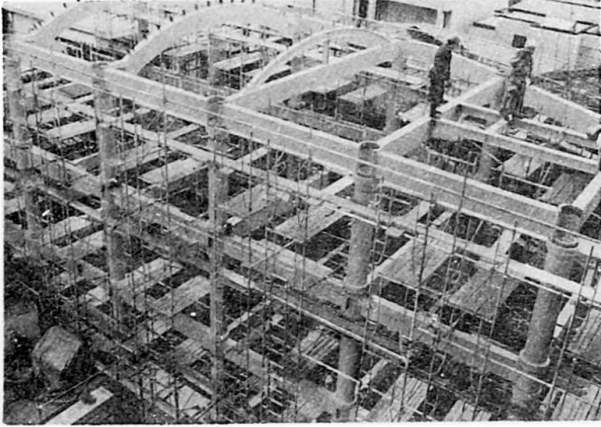

Fig. 7 Whole structure

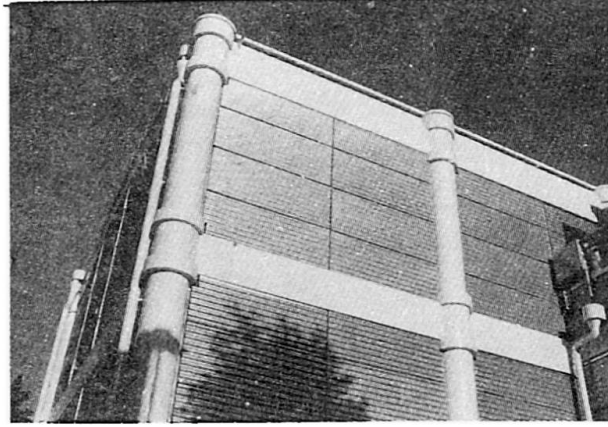

Fig. 8 Completion

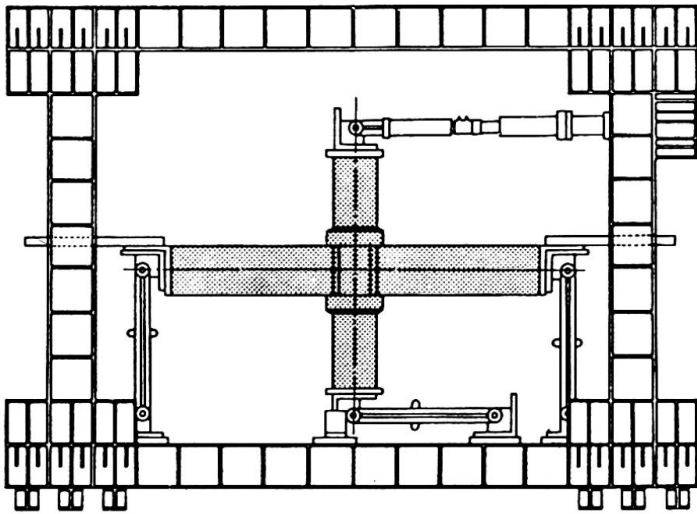

Fig. 9 Testing of column-to-beam joint

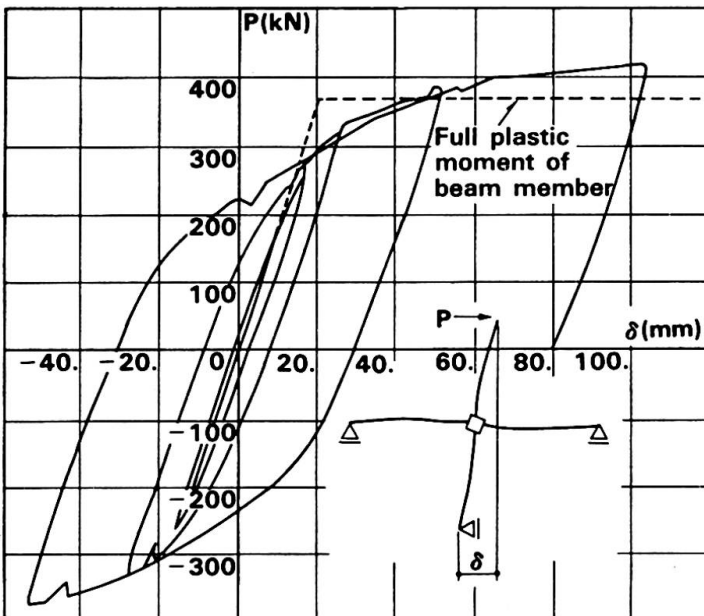

Fig. 10 Relationship of load and deformation

## 6. STRENGTH OF THE JOINT

In order to ascertain the structural strength of the joints of the structure of Fig. 4, an actual-dimension test was conducted on a cross-shaped column-to-beam joint (Fig. 9). During repeated loading at relative story deformation angles equivalent to  $1/50$ , the relationship of load and deformation showed a stable, spindle-shaped hysteresis curve (Fig. 10). The ultimate strength has been ascertained to be in excess of the strength level that corresponds to the entire plastic moment of the beam member. Also, as against the load that corresponds to the design earthquake load, the test piece proved to stay well within the range of elasticity, with deformations of less than  $1/200$  in relative story deformation equivalents. Furthermore, even in the ultimate state, strain in the beam ends and the curved plates was small, and no slipping out of the inserted portion was observed.

## A New Generation of Pressurized Water Reactors

Une nouvelle génération de réacteurs à eau sous pression

Eine neue Generation von Druckwasserreaktoren

### Günther KESSLER

Professor  
Nuclear Res. Center  
Karlsruhe, Germany



Günther Kessler, born in 1934 received his Mechanical Engineering Degree at the University of Aachen and his Dr.-Ing. Degree at the University of Karlsruhe, Germany, where he is now professor at the Mech. Eng. Dep. Since 1963 he is involved in reactor physics and reactor safety.

### Wolfgang BREITUNG

Dr.-Ing.  
Nuclear Res. Center  
Karlsruhe, Germany



Wolfgang Breitung, born in 1944 received his Degrees in Nuclear Engineering and his Dr.-Ing. at the University of Karlsruhe, Germany. He is involved in reactor safety research at the Nuclear Research Center of Karlsruhe since 1977.

### Josef EIBL

Professor  
University of Karlsruhe  
Karlsruhe, Germany



Josef Eibl, born in 1936, received his Engineering Degree at the Technical University of Munich, 1959, and Doctor Degree in 1963. He is Professor and Director of the Institut für Massivbau und Baustofftechnologie at the Technical University of Karlsruhe.

### SUMMARY

The feasibility of a containment design is studied for future nuclear power plants which are able to sustain extreme loading cases caused by severe core-melt accidents, such as hydrogen-detonation or steam-explosions. Several measures are considered to achieve a deterministically 'safe' design.

### RÉSUMÉ

Dans cette note on s'occupe de savoir si, pour les centrales nucléaires du futur, il est possible de réaliser des confinements qui puissent résister aux contraintes sévères d'un hypothétique et très grave accident de fusion du coeur, comme celui résultant de la détonation de l'hydrogène ou d'une explosion de vapeur. De nombreuses propositions constructives sont faites, en vue d'obtenir un confinement qui serait "sûr" de façon déterministe.

### ZUSAMMENFASSUNG

Der Beitrag geht der Frage nach, ob für zukünftige Kernkraftwerke Containments technisch realisierbar sind, die auch den starken Beanspruchungen eines angenommenen schweren Kernschmelzunfalles, wie sie etwa bei einer Wasserstoffdetonation oder einer Dampfexplosion auftreten, standhalten können. Es werden mehrere Konstruktionsvorschläge gemacht, um eine deterministisch, "sichere" Konstruktion zu erzielen.



## 1. FUTURE CONTAINMENT CONCEPTS FOR PRESSURIZED WATER REACTORS (PWR's)

In contradistinction to the numerous design proposals put forward for future small Pressurized Water Reactors, we aim our design criteria for future PWR's (beyond 2000) to reactors of a size similar to the existing 1300 MWe PWR's in Europe. In our design philosophy we eliminate in a deterministic way, i.e. beyond any reasonable doubt, the catastrophic consequences of containment destruction as discussed in the context of severe core melt accidents such as core melt-through of the containment basemat, steam explosion, H<sub>2</sub>-detonation, high pressure failure of the reactor pressure vessel or other primary system components and containment bypass leaks. Our overall safety concept is designed to provide an ultimate barrier which envelops in a protective sense the spectrum of preventive and mitigative accident management measures. In the following we will define design specifications that will mechanically prevent failure of inner and outer containment structures.

## 2. SPECIFICATION OF DESIGN MEASURES FOR THE CONTAINMENT STRUCTURES

In the very improbable case of core melting at low system pressure (e.g. a leak in the primary system followed by failure of all emergency cooling systems and relevant accident management measures) the molten core would penetrate the bottom of the reactor pressure vessel (RPV) into the concrete structures below. The chemical reaction between steam and zirkaloy or stainless steel contained in the core will cause a release of about 1500-1800 kg of hydrogen into the containment. Various analyses have shown that despite the presence of steam, the detonability limits of H<sub>2</sub> with air may be reached and even exceeded in certain compartments of the containment. On the basis of theoretical and experimental results on hydrogen detonations [5] our containment design specifications require the containment to withstand a global shock impulse of about 0.2 MPas and a static pressure of about 2 MPa. With these design specifications the containment would not fail even if large scale hydrogen detonations occurred or if steam pressurization would develop.

For the unlikely case of failure of heat removal via the steam generators and subsequent failure of depressurisation of the primary system, the core would melt and heat the bottom of the RPV until it fails. The multi-phase water-steam mixture together with the molten core would flush out of the RPV downwards into the reactor cavity. The main results of a recent analysis [6] show that thrust forces of about 300 MN would act initially and decay within 100 ms. To prevent an upward movement of the RPV, the vessel support structures must be designed to withstand 300 MN. Additional structures must be provided above the reactor vessel to keep the RPV in its original position.

After a core melt down at relatively low primary system pressure, the molten core masses may come in contact with water remaining underneath the core support structures inside the RPV and will eventually cause a steam explosion. This steam explosion may destroy the RPV and create missiles (e.g. pressure vessel head) that could penetrate the reactor containment ( $\alpha$ -mode failure). A preliminary assessment regarding the mechanical strength of the upper part of the RPV indicated that even an energy release of 3 GJ would not produce missiles that could endanger the integrity of the outer containment. However, additional inner containment structures will be provided to retain missiles released from the RPV. These inner containment structures would need to be located, most likely, both underneath and above the RPV.

After release of the core melt from the RPV into the reactor cavity, the molten core material would erode the concrete basemat of the containment. Recent experimental and theoretical studies on molten core-concrete interaction, performed mainly in the USA and Germany, have quantified the process of basemat erosion. A new containment design concept has to resist basemat erosion. This can be achieved by introducing a molten core retention and cooling device underneath the RPV [4].

An overall safety concept must also contain the prevention of bypass leaks, e.g. through pipes. All tubes and pipes penetrating the containment walls should be assembled in a few groups.



# COMPOSITE CONTAINMENT

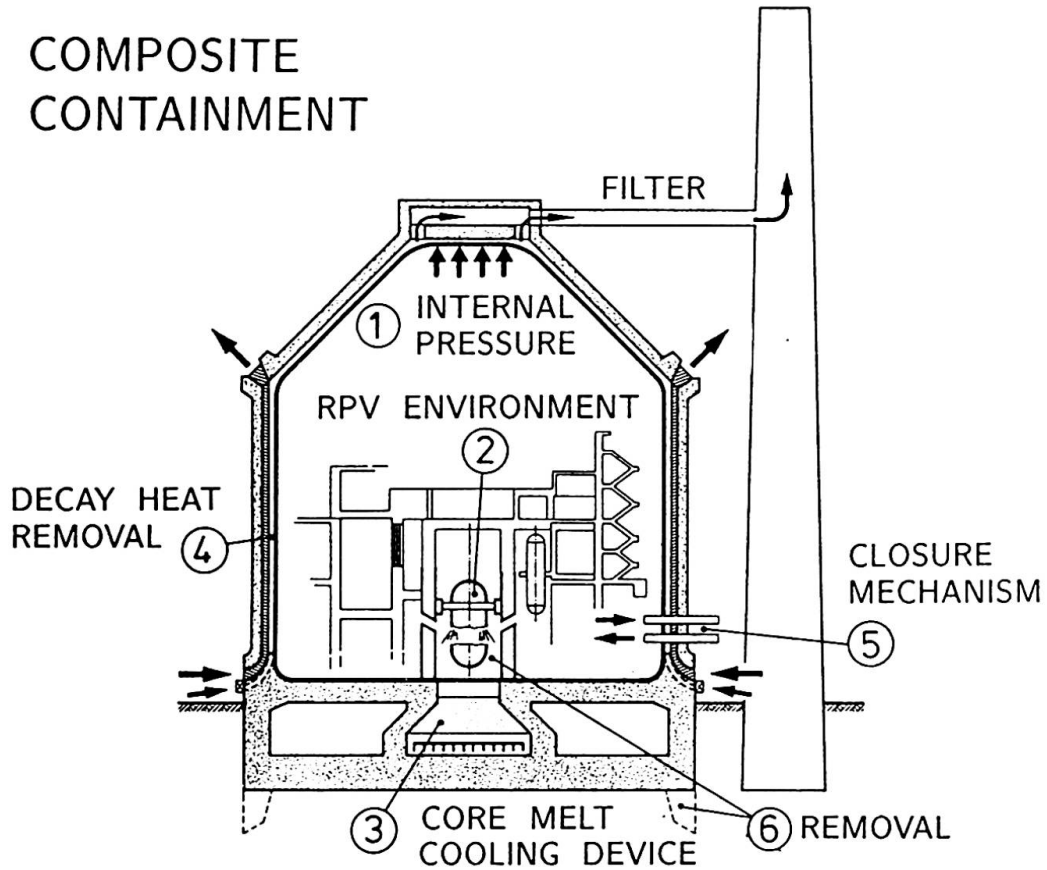

Figure 1 : Composite containment for a pressurized water reactor

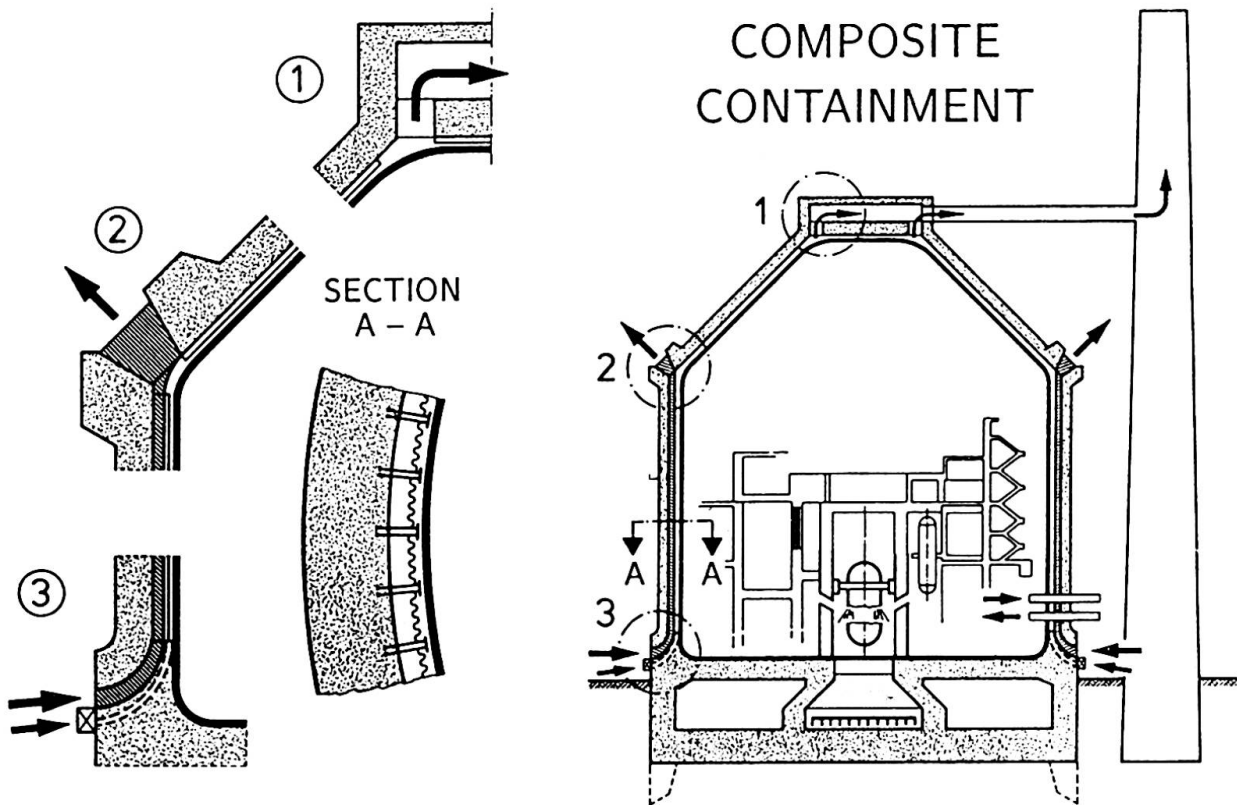

Figure 2 : Separation of the cooling air stream from the filtered air stream



External accident management measures must be made available to seal any pipes or valves whose closure mechanisms may fail in a severe accident.

### 3. CONTAINMENT DESIGN

Our novel containment design has been developed to achieve a deterministically 'safe' concept for nuclear reactors. The concept of safety has always been based on a purely probabilistic approach but, in reality, a possibility of failure still exists no matter how low the level of probability is. This applies even when the probability is reduced by a few orders of magnitude.

A reinforced concrete containment structure has a probability of failure of about  $p_C = 10^{-7}$ . Since the reactor must fail first, with a probability of less than  $p_R = 10^{-6}$ , then the probability of the two systems failing together will equal the product of the individual probability levels. In this case  $p_f = p_C \cdot p_R$  has a value of  $10^{-13}$  which is at least 6 orders of magnitude lower than current values which have been able to be reached up until now. A probability level of this order can be considered deterministically safe.

Beginning with the worst case scenarios discussed earlier the following must be considered (see also labels in Fig. 1) :

- 1 A static internal overpressure of 20 bars caused by decay heat development, and a dynamic one of 230 bars occurring within 5 ms that may result from a hydrogen detonation,
- 2 Pressure vessel failure under either a high system pressure or steam explosion,
- 3 Prevention of basemat erosion by retention and cooling of the molten core,
- 4 Passive removal of decay heat,
- 5 Closure of all tubes and pipes penetrating the containment wall, and
- 6 Removal of the pressure vessel, when the design life is exceeded, should be considered at the design stage.

Internal pressure problems resulting from either a static or dynamic loading case are well covered by the principal design of the proposed containment (Fig. 1). The building consists of a cylindrical wall structure covered by a conical shell. Both are divided into an inner steel shell and an outer reinforced concrete shell. The steel shell has a thickness of 38 mm, similar to those currently used for Convoy-reactors built by Siemens KWU. The concrete shell is about 2 m thick and protects the reactor against environmental threats, such as an airplane crash or gas explosion.

An 80 cm gap is provided between the inner steel shell and the outer concrete shell (Fig. 2). The gap is divided in the hoop direction by about 290 steel contact ribs which result in 50 cm × 80 cm compartments. These contact ribs ensure that both shells will act together as a composite structure when loaded by internal pressure. This also applies for the case of an inner hydrogen detonation. The inner steel shell does not touch the contact ribs under serviceability conditions. However, for extreme internal loading cases the steel shell will expand and come into contact with the ribs so that the steel and concrete shells will act together. A large opening in the two shells, about 9 m by 11 m, is needed for the material transportation lock and poses a design problem that is presently being studied.

The estimated extreme loads acting within the reactor pressure vessel cavity are labelled in Fig. 3 and are still under further investigation, as discussed in Section 2. For a pressure vessel failure, the upper vessel-head will be held in place using a restraining steel device connected to the upper concrete ceiling which is fixed with unbonded prestressing cables. The high pressure generated from large amounts of energy release will accelerate the lower half sphere into the reinforced concrete grid below. This allows the melt to reach the core catcher device that is located in the lower compartment. The pressures acting inside the pressure vessel cavity and the core catcher cellar are resisted by the reinforced concrete.



# REACTOR PRESSURE VESSEL ENVIRONMENT

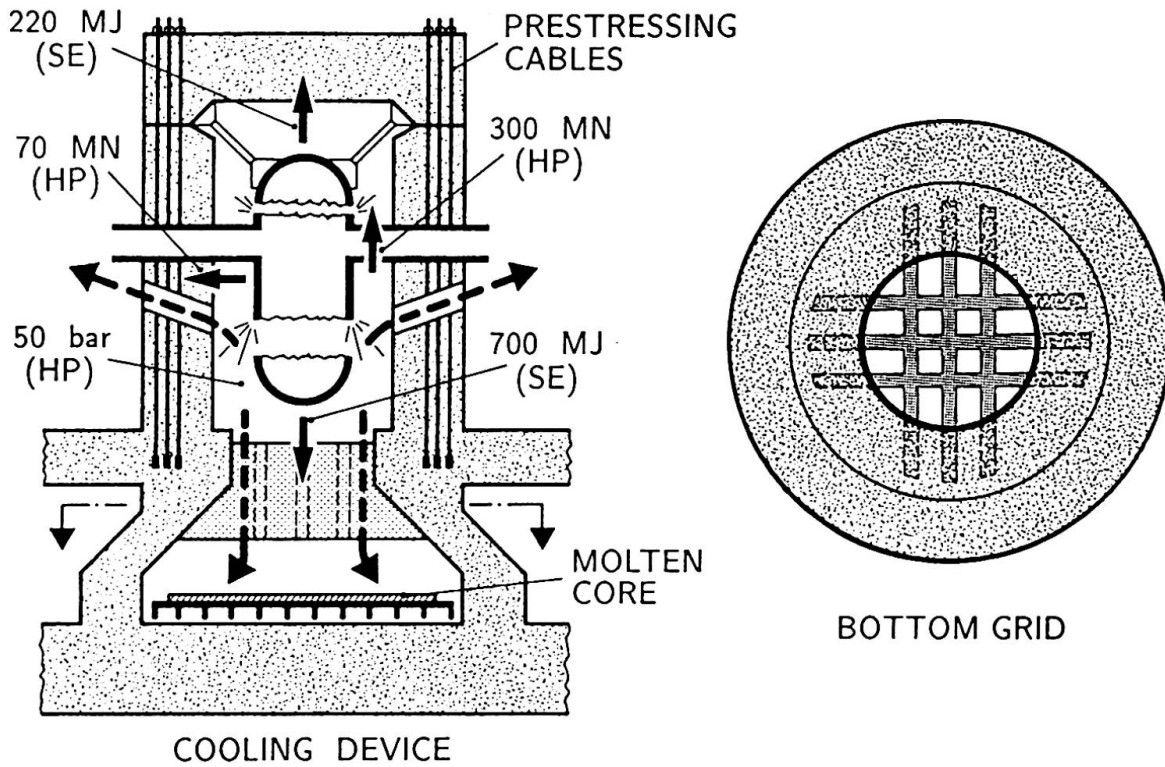

Figure 3 : Reactor pressure vessel environment and core-melt cooling device

## CLOSURE OF PIPES

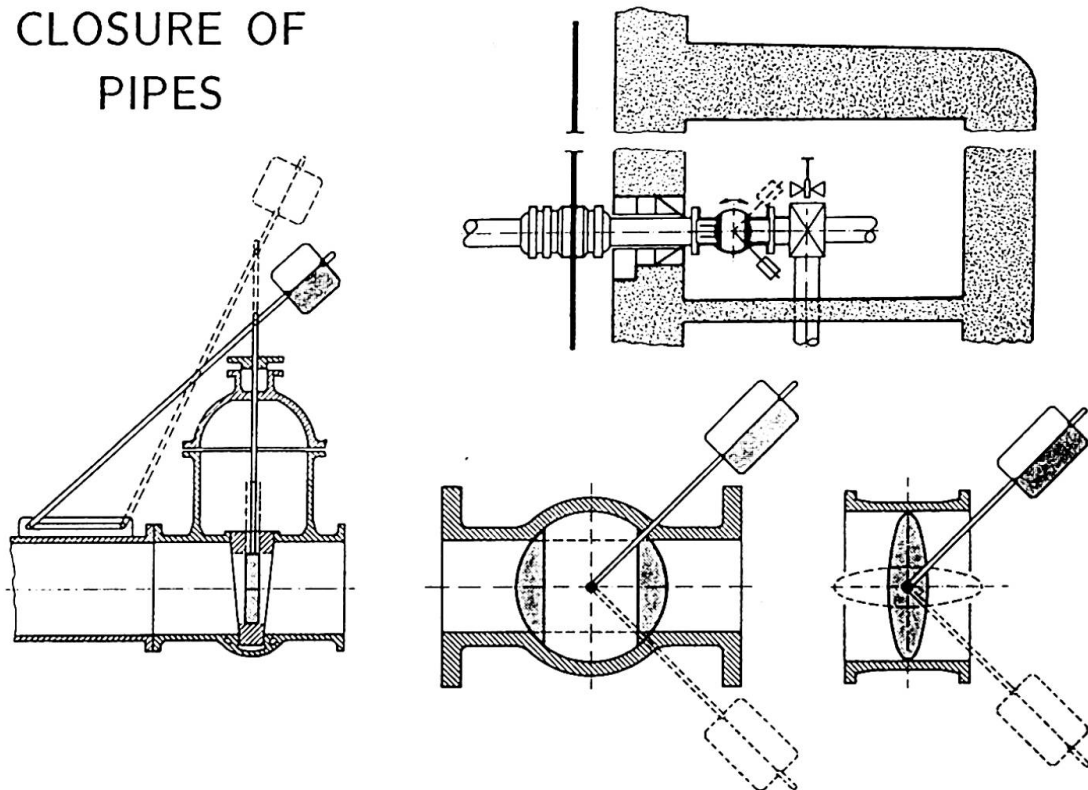

Figure 4 : Closure of penetrating tubes and pipes



The core-melt cooling and retention device (Fig. 3) is protected from the downward moving end-cap missile by the concrete grid. The molten core will be cooled from the top and bottom faces by using water evaporation to provide a circulation system that can operate completely inside the pressure resistant enclosure of the building. With this method the heat is transferred to the steel shell and then dissipated, via heat radiation, by the chimneys.

The compartments which are formed in the cylindrical part of the containment between the inner and outer shells, and separated by the contact elements, will form natural draft chimneys about 40 m high. Thermodynamic calculations have shown that they are capable of removing the released decay heat exclusively by passive means.

Considering that small leakages are unavoidable not only during accidents, but even under service conditions, it becomes necessary to control these leakages by filtering the air in contact with the inner steel shell. It is assumed that a possible leakage will occur in the close vicinity of any penetration points. The huge amount of air necessary to remove the decay heat would have required extremely large filter units, the latter slowing down the speed of the air stream. Consequently, an airtight layer of about 10 cm thickness is separated from the main chimneys by a flexible steel membrane (Fig. 2). The air stream that removes the decay heat is led only along the cylindrical part of the building, while the other air stream which could become contaminated is led along the whole inner steel shell and filtered at the top of the building. The inner air stream is joined with the conventional 150 m high chimney located next to the reactor building so that it will be under a lower pressure than the outer stream. This provides a passive way to prevent the cooling air from being contaminated, even under normal service operations. The separating membrane does not significantly influence the decay heat removal.

All tubes and pipes penetrating the inner steel shell have to be completely closed by mechanical means (Fig. 4) to ensure that no fission products will enter the environment. This system must be operable even under high pressure conditions. It is envisaged to concentrate these penetrations at a few points around the perimeter, similar to existing Convoy PWR's, and close them by devices currently used by conventional power plants [3].

In summary, a containment design which is able to contain a severe core-melt accident is feasible. This will protect the public by preventing any release of radiation into the environment. Since the cost of the reactor building for the last convoy PWR built in Germany represented only about 4% of the total costs, then the additional amount of money needed to strengthen the containment is not very hard to justify.

## ACKNOWLEDGEMENTS

Special thanks are given to Dr.-Ing. F.-H. Schlüter and Dipl.-Ing. H.Cüppers, co-workers of Prof. Eibl, for assisting in the design concept.

## REFERENCES

1. HENNIES, H.H., KESSLER, G., EIBL, J. (1989). Improved Containment Concept for Future PWR's. 5th Int. Conference on Emerging Nuclear Energy Systems. Karlsruhe, FRG, July 3-6, 1989.
2. EIBL, J. (1989). A new Containment Design for PWR's. SMIRT-Pre-Conference Seminar on Containment of Nuclear Reactors. UCLA - Los Angeles, CA, August 9-11, 1989.
3. MANG, F. (1990). Private Communications.
4. KUCZERA, B., ALSMEYER, H., KRIEG, R., EIBL, J. (1990). Considerations on Alternative Containment Concepts for Future PWR's. 2nd Int. Conf. on Containment Design and Operation. Toronto, Canada, October 14-17 1990.
5. BREITUNG, W. (1991). Conservative estimates for dynamic containment loads from hydrogen detonations. 11th Int. Conf. on SMIRT, Pre-Conference Seminar, August 14-16, 1991, Shanghai, P.R. China.
6. JACOBS, G. (1991). Estimation of Loads Acting during Reactor Pressure Vessel Blowdown at High Pressure. Am.Nucl.Soc. Winter Meeting San Francisco, November 10-15 1991.
7. EIBL, J. et al. (1991). Containments for Future PWR-Reactors. Int. Conf. Structural Mechanics in Reactor Technology (SMIRT 11), Tokyo, Japan, August 18-23 1991.