

Zeitschrift: IABSE congress report = Rapport du congrès AIPC = IVBH
Kongressbericht

Band: 14 (1992)

Rubrik: Special session 2: Offshore fixed and floating structures

Nutzungsbedingungen

Die ETH-Bibliothek ist die Anbieterin der digitalisierten Zeitschriften auf E-Periodica. Sie besitzt keine Urheberrechte an den Zeitschriften und ist nicht verantwortlich für deren Inhalte. Die Rechte liegen in der Regel bei den Herausgebern beziehungsweise den externen Rechteinhabern. Das Veröffentlichen von Bildern in Print- und Online-Publikationen sowie auf Social Media-Kanälen oder Webseiten ist nur mit vorheriger Genehmigung der Rechteinhaber erlaubt. [Mehr erfahren](#)

Conditions d'utilisation

L'ETH Library est le fournisseur des revues numérisées. Elle ne détient aucun droit d'auteur sur les revues et n'est pas responsable de leur contenu. En règle générale, les droits sont détenus par les éditeurs ou les détenteurs de droits externes. La reproduction d'images dans des publications imprimées ou en ligne ainsi que sur des canaux de médias sociaux ou des sites web n'est autorisée qu'avec l'accord préalable des détenteurs des droits. [En savoir plus](#)

Terms of use

The ETH Library is the provider of the digitised journals. It does not own any copyrights to the journals and is not responsible for their content. The rights usually lie with the publishers or the external rights holders. Publishing images in print and online publications, as well as on social media channels or websites, is only permitted with the prior consent of the rights holders. [Find out more](#)

Download PDF: 04.04.2026

ETH-Bibliothek Zürich, E-Periodica, <https://www.e-periodica.ch>



Special Session 2

Offshore Fixed and Floating Structures

Constructions en mer amarrees et flottantes

Verankerte und frei schwimmende Meeresbauwerke

Organizer:

Chr. J. Vos,
The Netherlands

Leere Seite
Blank page
Page vide

Floating Islands "Marinarium"

Iles flottantes "Marinarium"

Schwimmende Inseln "Marinarium"

Richard DZIEWOLSKI

Dr. Eng. Arch.
CCERET — ENGINEERING
Boulogne Billancourt, France



Richard Dziejowski born in 1935, obtained his civil engineering degree at the Polytechnical Institute of Warsaw (1958), his Doctor of Engineering from the Faculty of Science of the University of Paris (1963) and his Architect's degree DPLG in Paris (1970). In 1968 he opened his own Consulting Engineering firm called the CCERT-ENGINEERING and in 1970, his own Architectural firm Richard Dziejowski.

SUMMARY

This article presents the plans of two offshore "Marinarium" resort complexes which are covered by the author's patents and models. From 20 to 65 meters deep, the platforms are fixed, and from 50 to 2000 meters deep, they are floating.

RÉSUMÉ

L'article présente les projets de deux complexes de loisir offshore "MARINARIUM" qui ont fait l'objet de dépôt de brevets et de modèles par l'auteur: plateforme fixe pour 20 à 65 mètres de profondeur d'eau et plateforme flottante pour 50 à 2000 mètres de profondeur d'eau.

ZUSAMMENFASSUNG

Der Artikel stellt die Projekt der beiden Offshore-Vergnügungsparkkomplexe "Marinarium" vor, die zusammen mit den Modellen des Autors patentamtlich geschützt wurden: eine feste Plattform für 20 bis 65 m Wassertiefe und eine schwimmende Plattform für 50 bis 2000 m Wassertiefe.



1. INTRODUCTION

The technical progress made over these last two decades in the field of offshore engineering is expected to have a considerable influence on housing modes and on the leisure time activities of future civilisations.

Man came out of the sea and will return to the sea...

By the year 2000, we shall perhaps see floating islands springing from the sea, in varied shapes like so many lotuses at the edge of the waves...

Pretty speech, but in France the principle is running into major difficulty: the shorelands protection law which prohibits construction off the coasts.

These regulations are a major obstacle to the development of offshore construction. However, industrialists are hoping to be able to get around these rules one day by clearly proving that a floating island is considerably less polluting for marine fauna and flora than the "unrelieved concreting" of the coastlands.

A vast debate.

At present time is getting short; the needs are becoming acute:

* **Tourism:** increasing numbers of tourists and saturation of the seaside resort facilities during the summer.

* **Costs:** land near the shore is more and more scarce and more and more expensive.

* **Employment:** increasing numbers of unemployed in certain seaside towns due to a major crisis in offshore construction and in shipbuilding. Closure of many Mediterranean shipyards.

The Riviera, one of the most beautiful regions in the world, is practically saturated in the summer by millions of visitors from France and abroad.

A predictable increase in the number of foreign tourists in France in the coming years, larger household vacation and leisure activity budgets and more free time demand major efforts to adapt existing infrastructures to new market needs.

The magnitude of real estate taxes, traffic problems, difficulties in treating wastes and lack of drinking water make the construction of sea side resort complexes more and more difficult.

It has become necessary to look for new solutions.

2. OFFSHORE TECHNOLOGY AT THE SERVICE OF HOUSING, LEISURE AND ENTERTAINEMENT

Figures 1 to 8 represent a number of completed projects, to which our design firm has contributed; they demonstrate the technical possibilities of offshore construction.

Certain of these platforms contain residential neighborhoods and technical facilities providing them with full self-sufficiency.

The touristic interest of these projects can be considerably improved by appropriate architectural research, along with research into the choice of forms which fit the marine environment better than certain purely industrial structures.

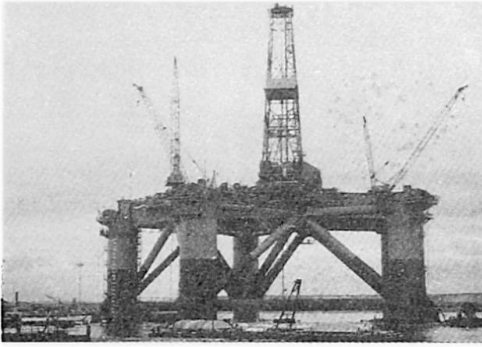

Fig. 1 Semi-submersible floating platform "PENTAGONE".

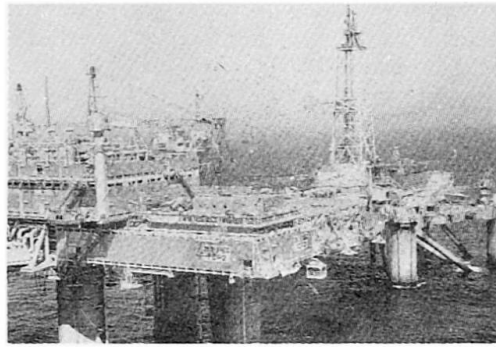

Fig. 2 Fixed gravity platform TCP2, Frigg North sea.



Fig. 3 Platform TCP2, during construction

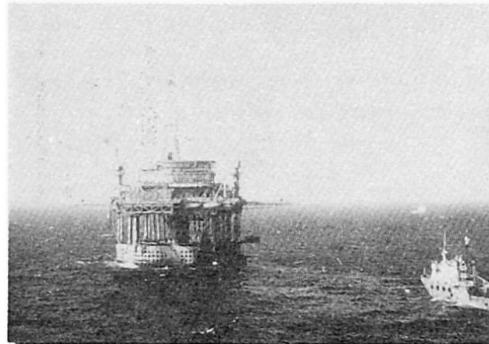

Fig. 4 Fixed gravity platform Doris, Frigg.



Fig. 5 Platform TCP2 under construction in Norwegian Shipyard



Fig. 6 Self-raising platform, "TRIGONE"

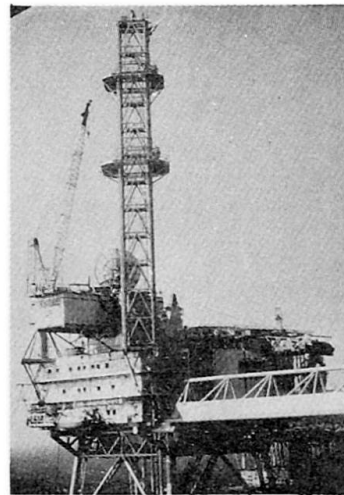

Fig. 7 Jacket Q.P Frigg (living quarters)



Offshore construction for tourist purposes must not only be easy to install, but must also be easy to service and therefore to dismount. Furthermore, this includes technical installations to make it fully self-sufficient while avoiding all risk of pollution for the environment.

The photos representing open sea offshore platforms demonstrate the colossal size of these works, designed to withstand the forces of hundred year swells, 28 meters high, winds of more than 200 km/h, and these platforms can be constructed at water depths greater than 150 meters.

The technical fallout from these works in the design and construction of buildings can be multiple.

3. "MARINARIUM" LEISURE AND ENTERTAINMENT COMPLEXES, EXAMPLES OF THE USE OF OFFSHORE TECHNOLOGY

The studies and research which we have been conducting for more than ten years in the field of leisure and entertainment equipment have led to developing two original tourist products which eliminate the disadvantages mentioned earlier. They are characterized by:

- Choice of an original architecture, fitting well into maritime sites, based on offshore technologies and constituting veritable monuments, an event, a tourist site, an entirely integrated concept.
- Into this monument, installing a leisure and entertainment complex which is exceptional by the diversity and quality of the activities, i.e. housing units, food services, sports, health therapy, seminars, conferences, training courses, exhibitions, retail shops, shows, concerts, games, etc... maintaining tourist activities throughout the year.
- Location of this complex off the coasts in natural settings, entailing no detrimental phenomena.

The first complex, with 5000 beds and 300,000 m² (about 3,000,000 square feet), called "MARINARIUM 01" is a gravity type platform for water depths from 30 to 60 m (Fig. 9, 10 and 11).

The second complex with 2000 beds and 175,000 m² (about 1,750,000 square feet), called "MARINARIUM 02", is a floating platform, cable anchored for water depths from 60 to 2000 m (Fig. 17,18 and 19).

The clientele for these complexes is:

- visitors (guided visits)
- non resident club members (users of the facilities with or without meals)
- residents (short and long stays plus inclusive charge for activities)

These two projects will be built and equipped entirely in a shipyard, then towed and installed on the site by the use of oil platform techniques (gravity platform or floating platform, anchored by cables).

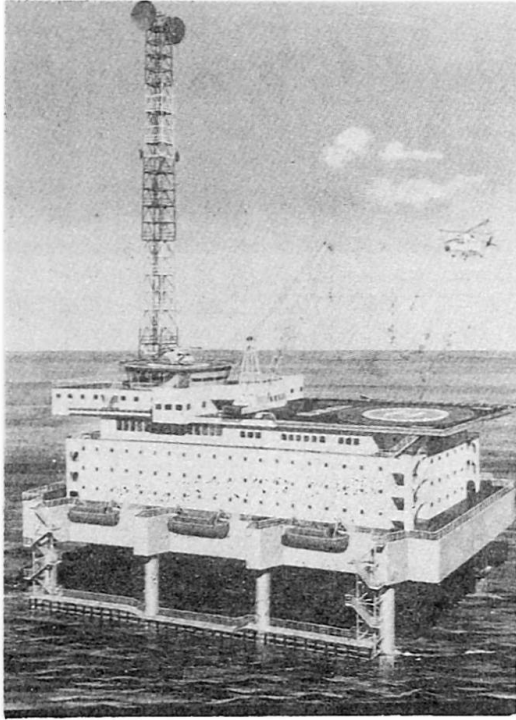

Fig. 8 Barge accomodation, Abu Dhabi Zakum

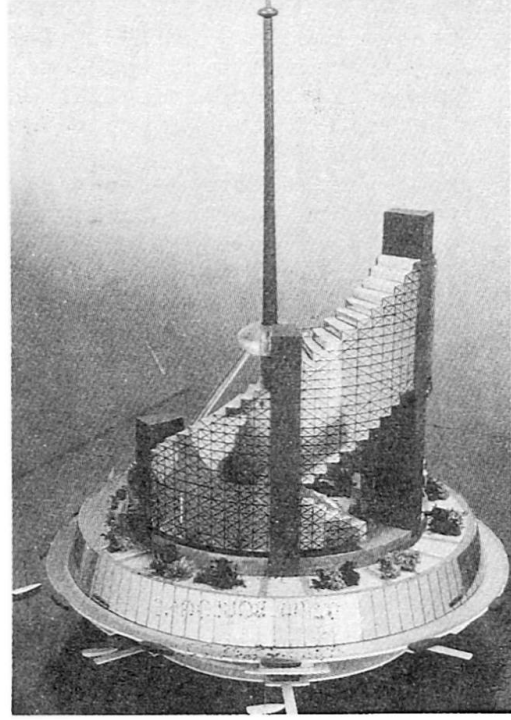
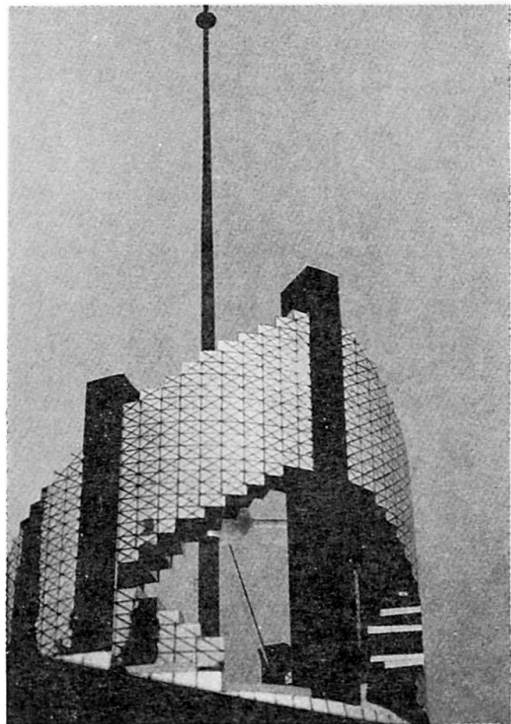
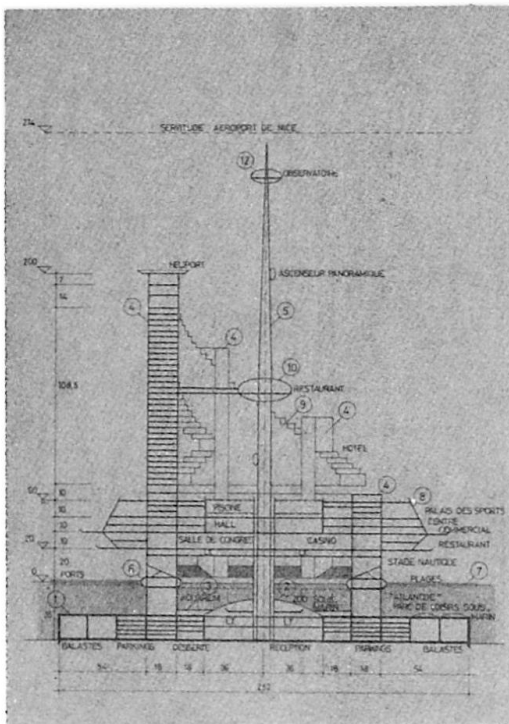

Fig. 9 And 10 photos of the scale module of the MARINARIUM 01 leisure and resort platform.

Fig. 11 Cross-section of the plan for MARINARIUM 01 - Location in Juan Gulf on the Riviera.





In the equipment rooms of these platforms, various facilities are located to guarantee complete self-sufficiency:

- sea water filtering and desalination installation,
- sewage treatment installation,
- household waste treatment installation,
- generator sets,
- fresh water storage tanks or reservoirs,
- hydrocarbon storage tanks.

A set of environmental specifications will be prepared in collaboration with the best specialists to avoid all risk of pollution.

The installation and dismantling of the "MARINARIUM 01" and "MARINARIUM 02" platforms will be easy, with no adverse effects on the environment (ballasting or deballasting of floats or of submersible gravity anchors).

These complexes, constituted as small self-sufficient towns, provide the inhabitants with an exceptional living environment with no detrimental phenomena.

4. DESCRIPTION OF THE "MARINARIUM" CONCEPT AND THE PLANS

4.1. The "MARINARIUM 01" plan

The general architecture and technical concept has already been described in our paper given at the thirteenth conference at Helsinki.

Figure 11 represents the proposed location of the complex in Juan Gulf on the French Riviera.

The plan includes a floating dike protecting the port against swell and an "anti-black tide" system.

The diagrams of the following figures describe the installation phase (fig. 12) and the way the helicoidal volume is built, utilizing prefabricated modules (fig. 13 to 16): orthotropic structure, weight of the module: approximately 26 tons, that is 180 kg/m².

This procedure can be applied in the construction of highrise buildings, thus enabling the creation of varied volumes.

4.2. The "MARINARIUM 02" plan

This plan concerns a floating "offshore" leisure and resort complex, which can be located near the coasts and connected to them with the aid of a floating bridge-tunnel (fig. 18 and 19), or it can be an independent island (fig. 17) containing a marina, sheltered by floating dikes, connected to the platform.

The surface area of the "MARINARIUM 02" platform is 175,000 m² (1,750,000 square feet) including 41,000 m² (410,000 square feet) of accessible terraces and decks, including:

- Lodgings, divided into 5***** hotels, hotel apartments and residential apartments.
- Offices, entirely equipped with built-in logistic services.
- Retail shops and restaurants.
- Areas for sports and leisure time activities (beaches, marina, swimming pools, tennis, golf, squash, water games, ping-pong, billiards, etc...),
- Health therapy (sea-water therapy, gymnastics, massages, sauna, beauty salons,...).
- "Culture-science-entertainment" areas (conference room, meeting rooms, exhibitions, concerts, shows, festivals, motion pictures, etc...).
- A casino.
- A marina.



3 PHASES DE CONSTRUCTION

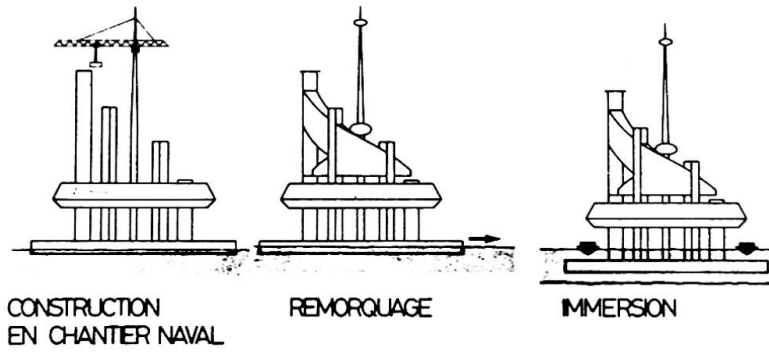

Fig. 12 Construction phases.

SCHEMA DE LA STRUCTURE

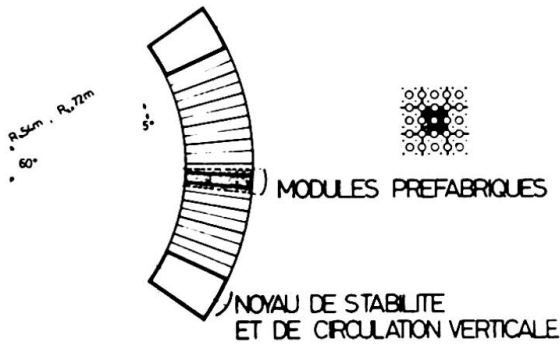

Fig. 13

COUPE TRANSVERSALE

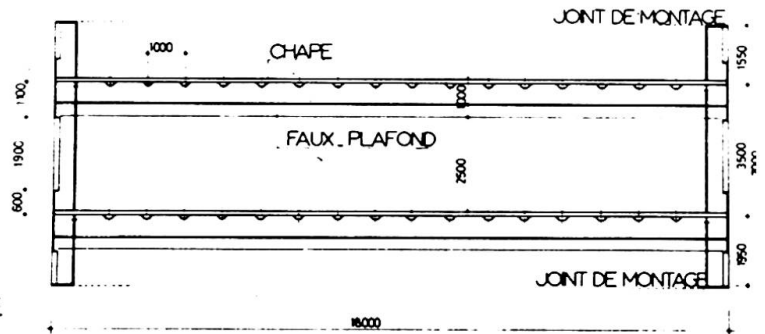

Fig. 14

VUE EN PLAN

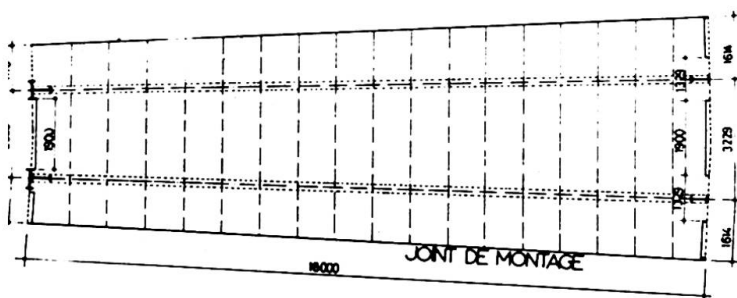

Fig. 15

MODULE PREFABRIQUE

FAÇADE EXTERIEURE R=72m.

FAÇADE INTERIEURE R=54m.

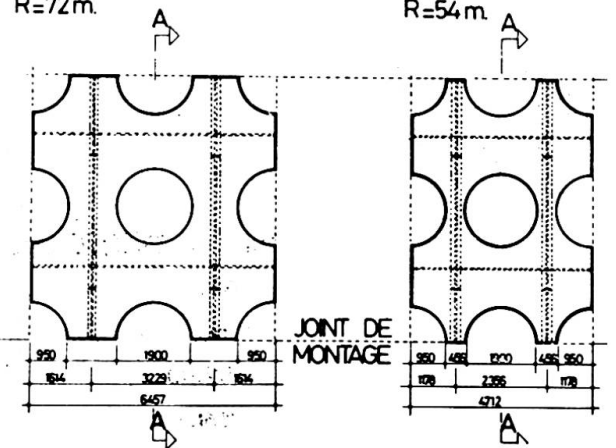

Fig. 16

Prefabrication details of the helicoidal volume by modules in Orthotropic structures.



- An under water oceanographic museum and amusement park.
- Night clubs, dance halls, discoteques.
- Parking for 800 automobiles and 4 buses.
- A heliport.

The originality of the concept is locating a hotel around a tropical garden - circular sports arena, 108 meters in diameter, covered by an air conditioned cupola-glass casing, for the practice of various disciplines throughout the year.

A special mechanism will make it possible to open and close the cupola in summer.

The exceptional quality of the lodgings and of the sports and amusement equipment will attract a large international clientele, always on the look-out for the latest developments, to participate in festivals, conferences, exhibitions, seminars, concerts, shows, private or professional visits, tennis and golf lessons, etc... in an extraordinary setting.

Technical characteristics of "MARINARIUM 02"

Maximum diameter: 245 meters (320 meters with floating dikes and the marina).
Height: 48 meters
Draft: 10 meters
Displacement: 190,000 tons.
Water depth: 50 to 2000 meters.
Type of anchoring: cables under tension (patented method).
Usable surface within the structure: 105,000 m² (1,050,000 square feet) (not counting parking areas and equipment rooms)
Overall surface: 175,000 m² (1,750,000 square feet) (including parking and equipment rooms).
Weight of the metal structure: 23,000 T to 42,000 T depending on the depth.
Storage capacity of reservoirs and ballasts: 50,000 m³.
Technical equipment and reserves: self-sufficiency for 30 days.
Protection of the port and beaches against the effect of swell by floating dikes, connected to the platform.

5. ANCHORING DEVICE

The type of anchoring proposed for "MARINARIA 02" will be the same as that developed by the author in 1972 as part of a T.L.P. study (CDP 2000), designed for oil drilling in deep waters.

(French patents no. 2408511 and 2408512 fig. 20 and 21)

The platform anchoring depends of the type of use and the weather conditions (wind, current, swell).

The planned anchoring system provides absolute safety with relation to the stability of the platform under all the operating phases (towing, lowering the gravity anchors into the water, drilling in storms, replacing cables, etc...).

It consists of:

- vertical cables,
- oblique cables in catenary.

The cables will galvanized anchoring cables, standardized AP1 of 3". The cables are multistrand, pulley mounted (the number of strands depends on

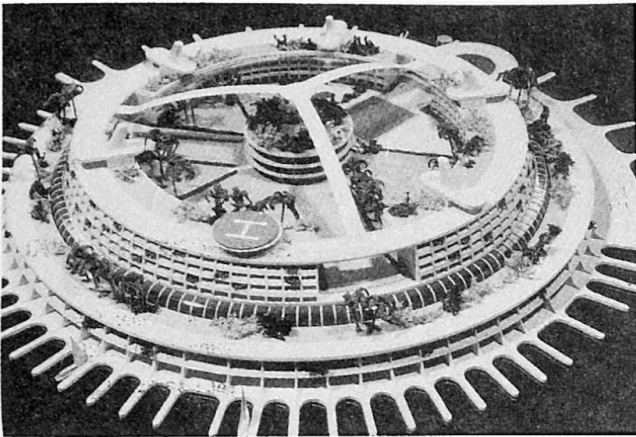

Fig. 17 Photo of the scale model of the MARINARIUM 02 floating leisure and resort complex.

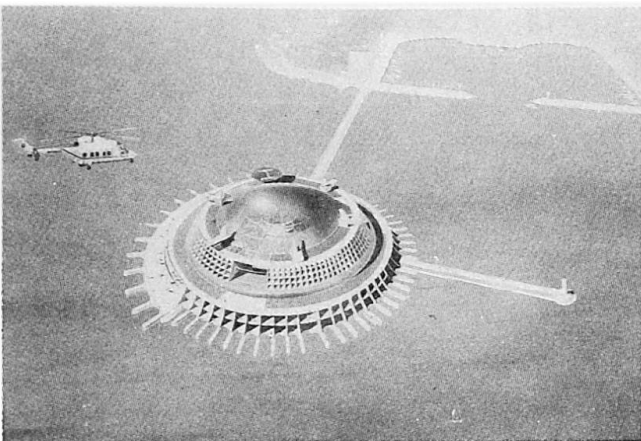

Fig. 18 Layout plan of MARINARIUM 02 in the port of Monaco.

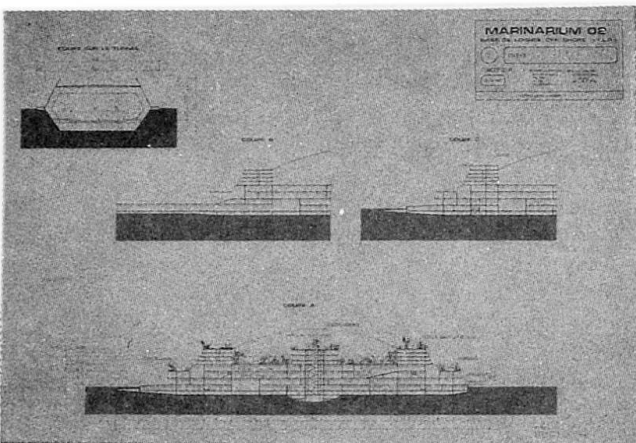

Fig. 19 Cross-section



the weather conditions, the depth, the live loads and the specific heave cycle which should not be long than 5 seconds). At the upper part, each vertical cable bundle is connected to the winch, and at the lower part, to the submersible gravity anchors.

The three anchoring winches per pier enable:

- lowering and raising the gravity anchors,
- adjusting the cable tension and length.

A special system has been designed to change the cables.

The oblique cables are also pulley mounted and connected on one side to the winch and on the other side to the submerged gravity anchor, or to concreted tubes.

The anchoring system chosen makes it possible to considerably reduce the side to side movement of the platform; this movement does not exceed 10% of the depth under the effect of wind, current and swell during storms.

The oblique cables reduce the stresses in the vertical cables and diminish the platform's yaw and roll movements.

The anchoring system depends on the intended use of the platform (with or without floating tunnel connecting the platform to the shore), on the weather conditions and on the depth.

Three solutions can be proposed

- Sloping cables in catenary and tensioned vertical cables (in case of the need of limiting the side to side movement and diminishing the heave - linking by tunnel to the shore).

- Sloping cables in catenary: in case the heave, pitch and yaw movements are not detrimental to the correct operation of the equipment (offshore location, depths not exceeding 500 m).

- Vertical cables: in case the side to side movement may be greater than 10% of the depth and for water depths greater than 500 meters.

The anchoring can be adapted to various depths from 50 to 2000 meters.

6. GRAVITY ANCHORS

The gravity anchors have three functions:

- floats during the towing phase (draft 12 to 14 meters)
- counterweights for anchoring the vertical cables
- storage reservoirs.

The platform can contain either several independent gravity anchors (fig. 22), or a single one (fig. 23).

The gravity anchors are connected to the platform by hoses and contain ballasting compartments.

The operations for installing the platform on the site are simple and rapid (fig. 24):

- towing the gravity anchors and the fully equipped platform to the site
- submerging the gravity anchors and the oblique cables which are connected to the buoy
- positioning the platform with the gravity anchors, adjusting the tensions on the oblique pulley mounted cables, connected to the buoy and to the winches,
- ballasting the gravity anchors,
- submerging the gravity anchors and descending them using winches (3 winches per pier)
- the complete ballasting of the gravity anchors and the adjustment of the tensions in the vertical and oblique cables with the aid of winches.

PL. 2/2 2408511

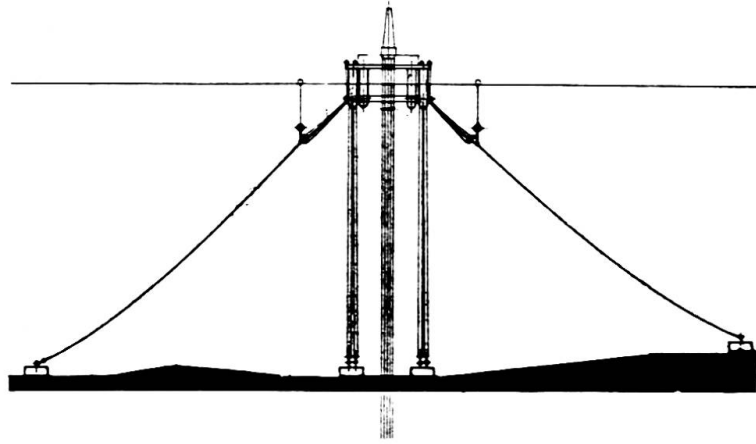
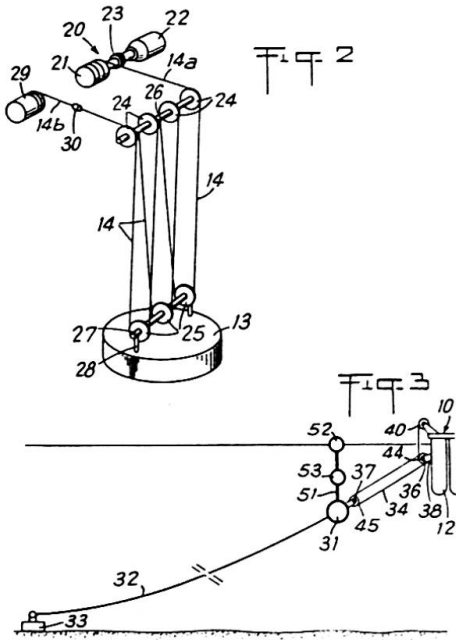

Fig. 21 Anchoring system, consisting of vertical and oblique cables.

Fig. 20 Anchoring diagram, using pulley mounted cables.

Fig. 22 Independant submersible gravity anchors.

Fig. 23 Single gravity anchor, storage tank.

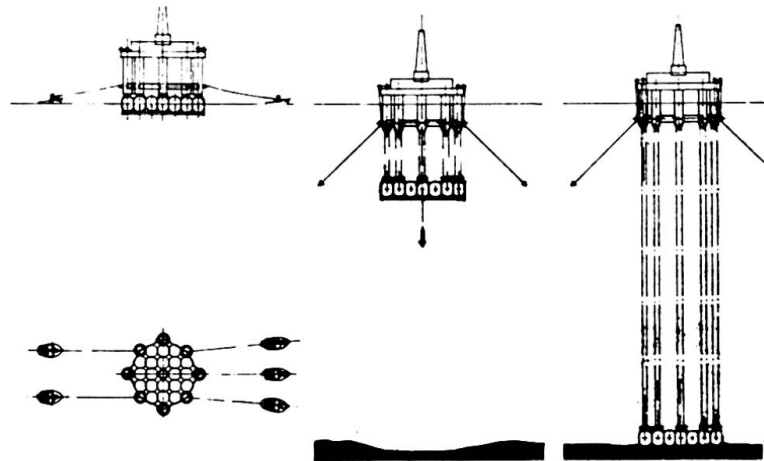
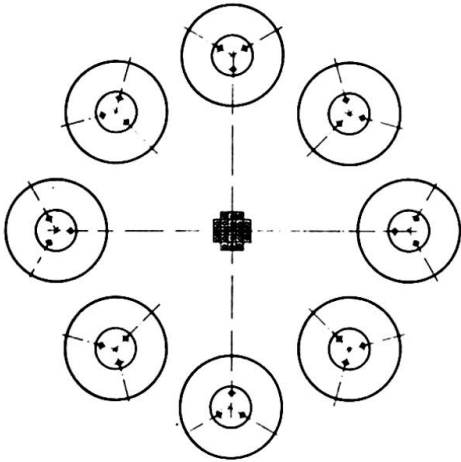
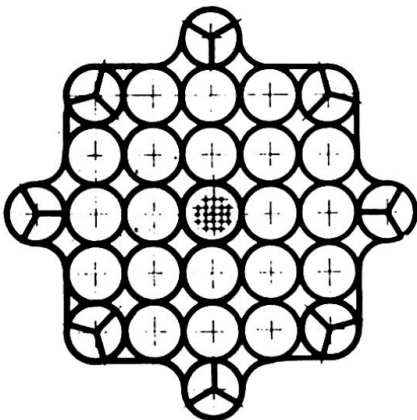

Fig. 24 Diagram of platform installation on the site.





7. EXAMPLE OF A CALCULATION OF ANCHORING FOR A DEPTH OF 500M

PROGRAMME CATMAN
SCHEMA D'ANCRAGE OBLIQUE

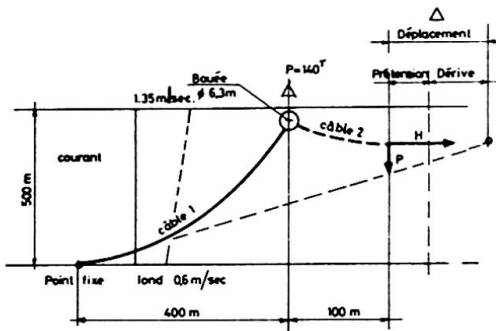

Câble 1 - Longueur 680 m : poids 175 Kg/m
Câble 2 - Longueur 110 m : poids 130 Kg/m
E = 1 900 000 Kg/cm²

Extreme phase HYPOTHESES :
wind : speed 62.5 m/sec, current :
speed 1.35 m/sec, swell 17.4 m/12 sec

The calculations were performed, statically and dynamically, to make it possible to determine the movements of the platform and the stresses in the cables for various time durations, under the effect of swell, current and wind, Figures 24,25 and 26 summarize these results.

Fig. 25 Calculation and design model of the oblique cable.

Fig. 26 Diagram of the variation of the tension in the oblique cable.

Fig. 27 Diagram of the horizontal components in the vertical and oblique cables.

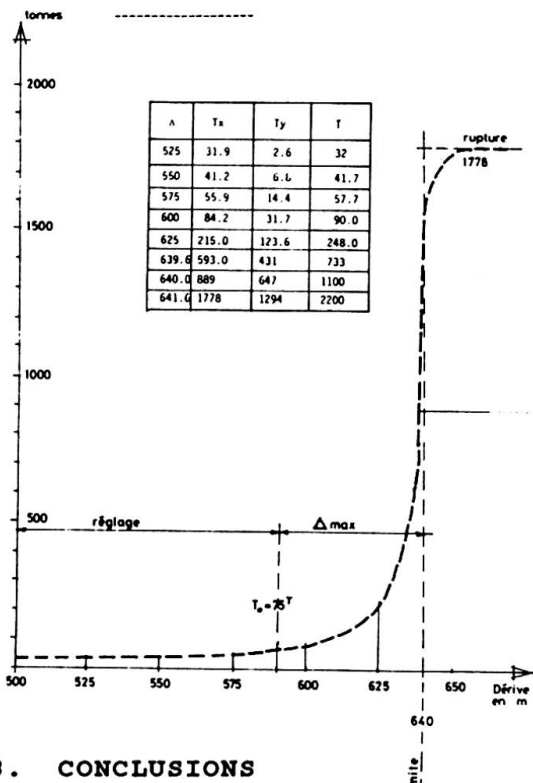

Variation de la composante horizontale dans les câbles en fonction de la dérive de la plate-forme.

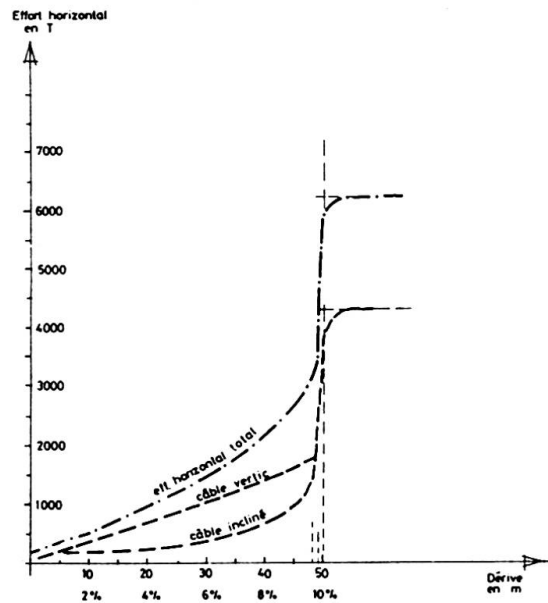

8. CONCLUSIONS

History demonstrates, that major architectural works contribute to enhancing the touristic value of towns and regions, sometimes even nations. The impact of these works on the public makes it possible to launch new architecture styles. The time has come for launching an architecture for the year 2000 : THE ARCHITECTURE OF THE SEA which will become our newest continent. By participating actively in the promotion of exemplary and spectacular projects, public authorities, investors and industrialists will be better able to channel the advertising impact of these projects and profit better from the considerable fallout, (not forgetting the shore law which, in the immediate future is braking the developpement of these concepts...)

Wave Energy Caisson for A Power Plant

Caisson pour une centrale d'énergie houlomotrice

Caisson für ein Wellenenergie-Kraftwerk

V.S. RAJU

Prof. Dr.
Indian Inst. of Technology
Madras, India



Prof. Raju, born in 1940, received his Bachelor and Master Degrees in India and Dr. Ing. Degree from Technical University, Karlsruhe, Germany. For 30 years he was active in teaching, research and consultancy in the areas of Foundation Engineering (Onshore and Offshore) and Ocean Energy. Currently, he is Dean, Industrial Consultancy and Sponsored Research at IIT, Madras.

SUMMARY

A wave energy power plant is being erected off the south-west coast of India near Trivandrum. The system has a caisson in reinforced concrete, resting on a prepared sea bed. The caissons can simultaneously be used as a breakwater for a harbour. The caisson was built and placed in position in December 1990. The paper explains the concept of the caisson type facility and describes its analysis, design, construction and installation aspects.

RÉSUMÉ

Une centrale électrique est en cours de construction sur la côte sud-ouest de l'Inde, à proximité de Trivandrum. L'ouvrage comporte un caisson en béton armé, reposant sur une assise préparée sur le fond marin. Ce type de caisson peut même servir comme brise-lames dans un port. Il a été construit et mis en place en décembre 1990. L'article expose la conception, le calcul statique, le dimensionnement, la construction et différents aspects d'installation de ce modèle de caisson.

ZUSAMMENFASSUNG

Vor der Südwestküste Indiens (nahe Trivandrum) wird zur Zeit eine Anlage zur Stromerzeugung aus Wellenenergie erbaut. Zum System gehört ein Stahlbeton-Caisson, der auf dem vorbereiteten Meeresboden gegründet ist und in dieser Art auch als Wellenbrecher vor Häfen dienen könnte. Der Caisson wurde im Dezember 1990 gebaut und eingeschommen. Der Beitrag erläutert die Funktionsweise sowie Aspekte der Berechnung und Konstruktion, des Baus und der Installation.



1. PROJECT OVERVIEW

1.1 Introduction

Wave energy is one of the promising forms of renewable energy which has received considerable attention. Sponsored by the Department of Ocean Development, Government of India, a pilot Project to generate electricity from ocean waves is under implementation off Trivandrum coast by the Ocean Engineering Centre, IIT, Madras. The system consists of (a) Concrete Caisson (b) Power module mounted on the top which comprises of a butterfly valve, an air turbine and an induction generator. Fig.1(a) shows the cross section of the system, 1(b) the plan of caisson, 1(c) the location plan and 1(d) the cross section showing the system, breakwater and the approach bridge.

1.2 Principle of operation

The Oscillating Water Column (OWC) concept is chosen. The OWC consists of a chamber exposed to wave action through an entrance in the front. Due to wave action the air inside the chamber gets compressed and rarified. The air movement is used to drive an air turbine (Fig.1a).

1.3 Functional requirements

The OWC chamber dimensions were selected to make it resonate with the incoming wave. Since the wave parameters vary from time to time and from place to place, it is very important to see that the device absorbs wave energy equally well in the range of wave climate predominant at the site. This means that the device should have a very broad frequency bandwidth of absorption. The device is tuned for an optimum wave period of 10 seconds.

1.4 Site for sea trial

The choice of site was arrived at based on the following criteria:

-Power availability: From the analysis of wave data collected at several places along the country's coastline it was found that wave power along Trivandrum coast is promising (Fig.2) with an annual average wave power of 13 kW/m length of coast .

-Extreme Wave Conditions: The OWC caisson must be designed to withstand the extreme wave likely to occur at the particular site. The maximum wave recorded for Trivandrum coast was only 6m between 1983 and 1987. On the other hand waves upto 9m have been measured on the east coast. The design wave near Trivandrum is smaller. It is also known that during the last 100 years no cyclone crossed the west coast near Trivandrum.

-Construction facilities: The fishing harbour at Vizhinjam near Trivandrum offered the required infrastructural facilities for the construction and installation of the caisson.

-Sea Bed: The sea bed at chosen location consists of medium to coarse sand, densely packed, offering a good base for supporting the gravity structure.



2. WAVE ENERGY CAISSON

The wave energy caisson comprises of a bottom box 23.2m x 17m x 3m high, supporting a 12m high chamber with a curtain wall in front and guide walls on either sides to facilitate wave entry (Fig.1a & b). Over the chamber is a double cubic curve concrete dome 10m x 7.75m at bottom reducing to 2.0m diameter circle at top and 3m high to support the power module. The caisson top is at +5.00m with respect to still water level.

3. DESIGN PARAMETERS

3.1 Operating Condition :

The system is expected to deliver a peak power of 150 KW at significant wave height of 1.52m and design wave period of 10 seconds.

3.2 Design extreme condition :

Based on the wave data collected off Trivandrum coast the design non-breaking and breaking wave heights were estimated to be of 7.0 mts. with a period of 10 secs.

3.3. Estimation of wave forces :

The estimation of wave forces on large rectangular or square caisson itself is complex. Unlike for circular cylinders, the incident wave direction has a significant influence on the forces. As the OWC caisson, has an opening on one side, the estimation of wave forces becomes uncertain because of the complex fluid flow and wave oscillations inside it.

For the estimation of non-breaking wave force, all the known procedures have been tried and finally, the method proposed by Isaacson [3] was used. The maximum wave force works out to 14000 kN. Finally the structure was designed for 15000 kN.

The front lip wall is a critical part of the caisson. The total average dynamic pressure at SWL due to breaking wave height of 7m calculated according to Minikin [4] is 1.18 MPa and the lip was designed for this. The total magnitude of breaking wave force is about 30000 kN. For future designs, elaborate measurements from a prototype structure and scale model studies in the laboratory are essential for an assessment of the breaking wave forces.

3.4 Scour Protection :

Scour Protection model studies conducted at the Ocean Engineering Centre show that scour is a linear function of current velocity and the maximum scour occurs at points 45° to the flow direction. Superposition of waves on current results in an increase of scour depth by 20% to 62%. The currents were found to be very less at the location of the caisson.



4. STRUCTURAL ANALYSIS AND DESIGN

After considerations of several possible alternatives, cellular construction was chosen for the walls, lip and bottom raft. The caisson structure was analysed using finite element method for global and local forces. The material is RCC with M30 grade concrete. The components of the structure to be designed are walls, lip, bottom raft and dome.

4.1 Walls and lip

The caisson walls are analysed using thin quadrilateral (flat) shell elements with 30 degrees of freedom. They are assumed to be fixed on the raft and consequently all the degrees of freedom at the bottom are arrested. As the wall is assumed to be a thin plate, it is rigid in its own plane and hence all the degrees of freedom (rotational) perpendicular to its own plane are arrested. The lip was analysed using thin shell elements. It was considered free at top and bottom and connected to the side walls. The maximum bending moments and dimensions of the back wall, side wall and lip are as follows:

Component	Maximum Bending Moment kNm/m		Wall width (mm)	Thickness of vertical panel (mm)	Thickness of horizontal diaphragm (mm)
	Horizontal direction	Vertical direction			
Back wall	+ 318	+297	2500	200	250
Side Wall	-1440	-616	2000	200	250
Lip	+4000	+363	2000	250	400

4.2 Raft

The raft is also analysed using thin plate elements and is assumed to be resting on equivalent soil springs. The reaction from the bottom most elements of the wall (due to wave forces) are also taken as part of the load on the raft.

The maximum bending moments along the length and width of the bottom raft and its dimensions are as follows :

Max. Bending moment (kNm/m)		Height of the box (mm)	Thickness of horizontal slab (mm)	Thickness of vertical walls (mm)
along the length	along the width			
-553	-208	3000	(top) 200 (bottom) 250	200



The raft was checked for the stresses during the various stages of construction of the caisson in floating mode.

4.3 Dome

The dome consists of two cubic parabolas meeting at mid height, the height of the dome being 3.0m. The sectional profile of the dome varies from place to place and it has a quadrantal symmetry. Finite element analysis was carried out using thin plate and shell elements of the SAP finite element library. The dome has been designed for the following load cases.

- Internal pressure of 1 bar + self weight of dome + weight of power module.
- Internal pressure of -0.5 bar + self weight of dome + weight of power module.

The maximum membrane force and moment considered for the design are 500 kN/m and 58 kNm/m respectively. The thickness of the dome is 25 cms and the percentage of steel is about 1.5% of the cross sectional area of dome in the meridional direction.

4.4 Stability of Caisson

The caisson should be stable against overturning and sliding at its final location. Stability is to be ensured during various stages of construction and towing.

4.4.1 During construction and towing :

As the caisson is not symmetric about its transverse axis, it tilts when it is floating. To correct this tilt, predetermined quantities of sand were added in the chambers of the bottom box. The metacentric height was always ensured to be not less than 5% of the draught. The draught of the caisson during towing was 9.75m.

4.4.2 On the prepared sea bed :

The structure has adequate factor of safety (F.S. > 1.5) both against horizontal sliding and overturning for non breaking wave forces. The author is of the opinion that the breaking wave force need not be considered for overall stability. However, even for this condition the F.S. is greater than 1.

4.5 Material Quantities

Some of the approximate quantities of the materials used for the construction are

Concrete	-	1020 cubic mts.
Reinforcing steel	-	1450 kN
Structural steel	-	1100 kN
Stones for Sea bed foundation	-	6200 kN



Stones for scour
protection around
caisson

8000 kN

5. CONSTRUCTION ASPECTS

5.1 Caisson

The caisson construction and installation are of major importance, particularly in view of the fact that no slip ways or heavy-lift facilities are available at the site. Keeping in view, the bathymetry, site conditions and availability of the harbour (Fig. 1c) the following methodology was adopted. Figs. 3a-d show the major sequences of construction.

-The bottom concrete box 3mt. height, was constructed in a pit 5m deep, on the beach area inside the harbour. The water table was held down below the construction level by well point dewatering system.

-The bottom box was made to float by allowing the water table to rise. Subsequently, the sand bund between the pit and the harbour basin was breached.

-The box was then towed to deep water area near a jetty where further construction of walls and other portions was continued in floating mode. Climbing forms were used for the construction of walls to achieve accurate alignment and speed of construction. As the construction proceeds the draught of this asymmetric structure increases and hence to ensure floatation, a temporary steel gate was erected in stages to close the front opening. Gate has over all dimensions of 10m x 10m x 1m and was held in position by lock channel arrangement. The level of the structure was kept by ballasting the different chambers of the bottom box with sand/water.

5.2 Dome

Because of the special shape of the dome, the shuttering work was expensive and labour intensive. Wooden joists were cut to lines and levels to form the basic shape of the dome on which plywood shuttering were fixed. The form work for the dome started from the bottom box slab which is 15 meters below.

5.3 Sea Bed Preparation

Along with the construction of caisson, a sea bed was prepared at the final location for the proper seating of the caisson. An area of about 30m x 23m was marked on the sea bed and stones of 20mm to 40mm size were neatly packed to lines and levels to form an even horizontal bed. Stones were conveyed using pontoons and dumped from it. The bed preparation was done by divers. The top level of the foundation was checked by conducting soundings and taking fly levels. Underwater photographs provided a fairly good indication of the evenness of the bed.



6. TOWING AND SEATING

The towing and seating operation of caisson was a very critical one with regard to the Project which needs meticulous planning. The caisson was towed out of the harbour to the final location using powerful tugs at the aft, stern and abreast. Powerful fishing trawlers also assisted in the operation. The caisson was installed on the prepared sea bed on 31st Dec. 1990. The exact positioning was done by controlling winches on board the caisson connected to bollards on the shore and anchors on the seabed.

Subsequently, a steel bridge (45m long) was erected to span the caisson and breakwater for the transport of power module and access to caisson top (Fig.3d).

7. POWER MODULE

The power module mounted on top of the dome consists of an air turbine of 2m diameter coupled to an induction generator of 150 KW rating. The induction generator system has been selected because, it is cheaper and does not require rectification and inversion normally associated with a variable speed alternator. The induction generator also has the advantage that it can be used as a start up motor for the air turbine when the wave heights are low. Thus the induction generator will always be connected to grid, drawing power from mains when the turbine speed is below synchronous speed and pumping power to the grid when the speed of turbine increases above the synchronous speed. When the grid fails, the turbine will race and attain a very high speed. To prevent this, a butterfly valve has been provided between the turbine and the caisson.

ACKNOWLEDGEMENT

The material presented here is a part of the work done under a project sponsored by the Department of Ocean Development, Govt. of India and implemented by IIT Madras. Many colleagues, Project Officers within IIT and many organisations from outside from outside assisted in the Project implementation. The Harbour Engineering Department of Kerala Government was responsible for the local infrastructure and construction. The structure was built by L & T - ECC Construction Group. The same is gratefully acknowledged.

REFERENCES

1. Final report on scientific investigations on wave climate, wave regulation and wave power. Report submitted to DOD by the Wave Energy Group, Ocean Engineering Centre, Indian Institute of Technology, Madras, Feb, 1987.
2. GODA, Y. New wave pressure formula for composite breakwaters. Proceedings of the 14th conference on Coastal Engineering, 1974.
3. ISAACSON, M. de. St. Q. Wave forces on rectangular caissons. Proceedings of the Civil Engineering in the Oceans, IV, ASCE, San Fransisco, Vol I, 1979.
4. MINIKIN, R. R. Wind, Waves and maritime structures. Studies in the harbour making and protection of coasts. 2nd edition, Griffin, London, 1963.
5. Sea Trial of a 150 KW wave energy device off Trivandrum coast. Project report submitted to DOD by the Wave Energy Group, Ocean Engineering Centre, Indian Institute of Technology, Madras, 1987.

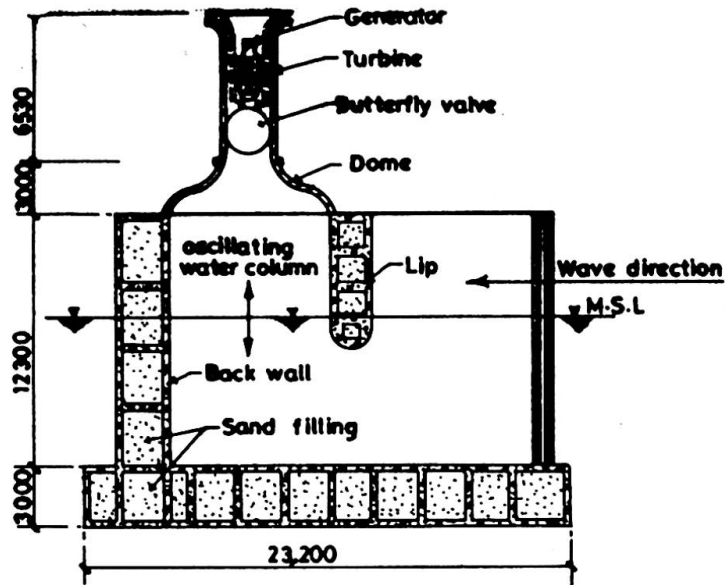

Fig.1.a Cross section of wave power plant

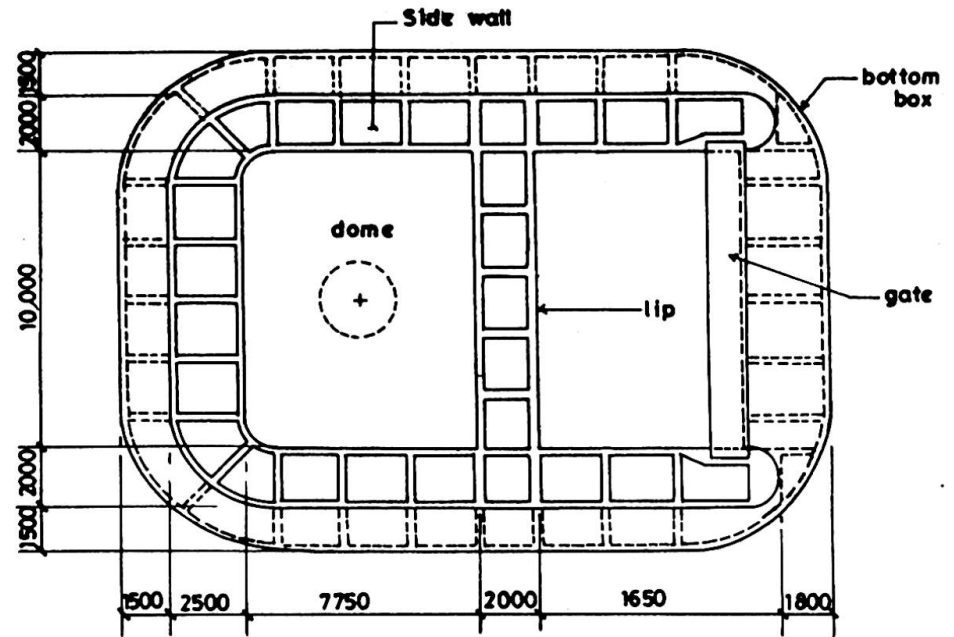

Fig.1.b Cross sectional plan of Caisson

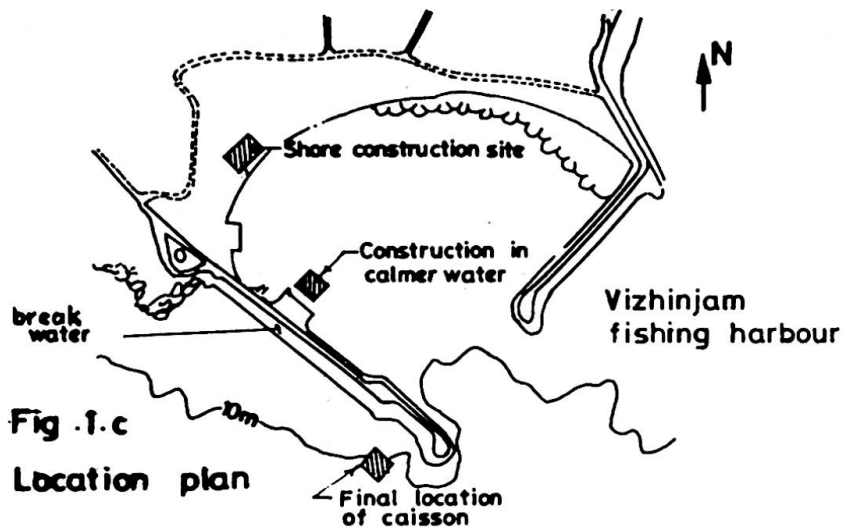

Fig.1.c Location plan

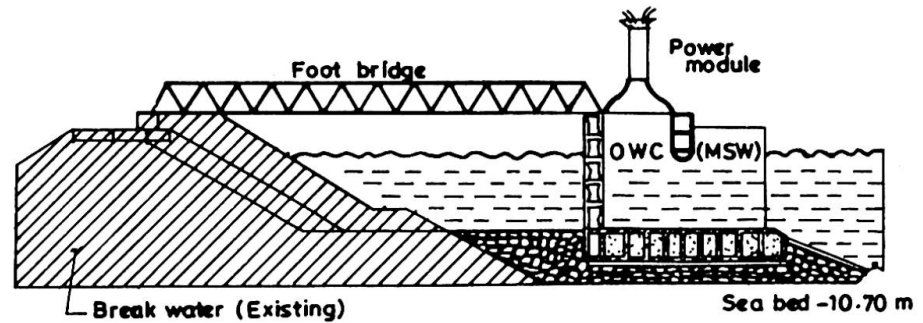

Fig.1.d Cross section of wave energy device and break water



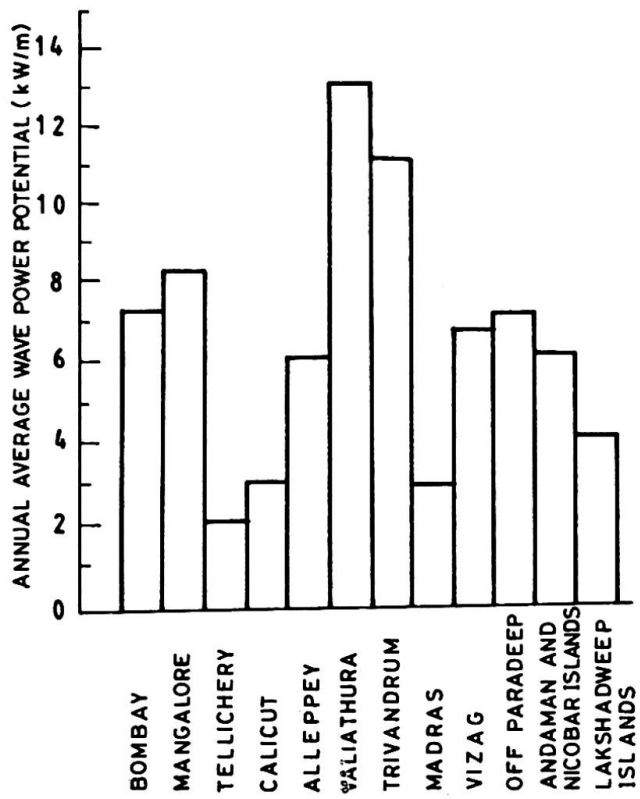

FIG. 2. WAVE POWER POTENTIAL ALONG INDIAN COAST

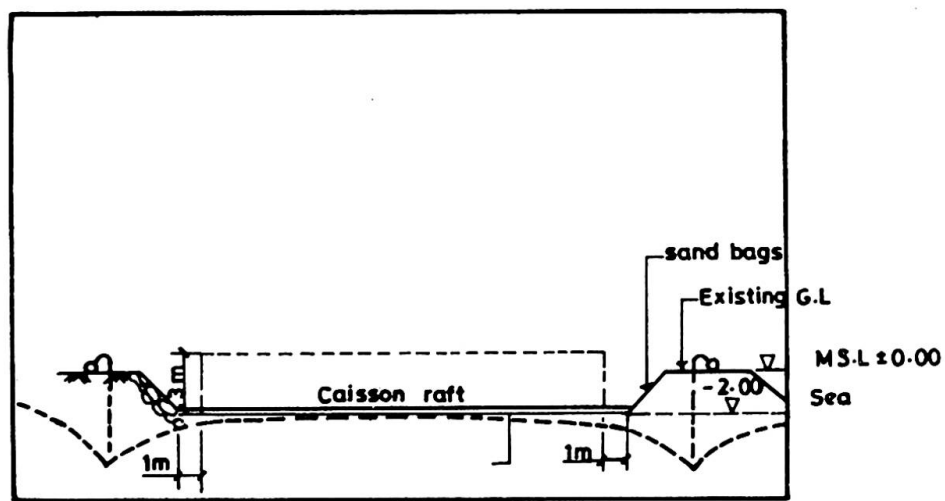

Fig. 3.a Construction of bottom box and bund

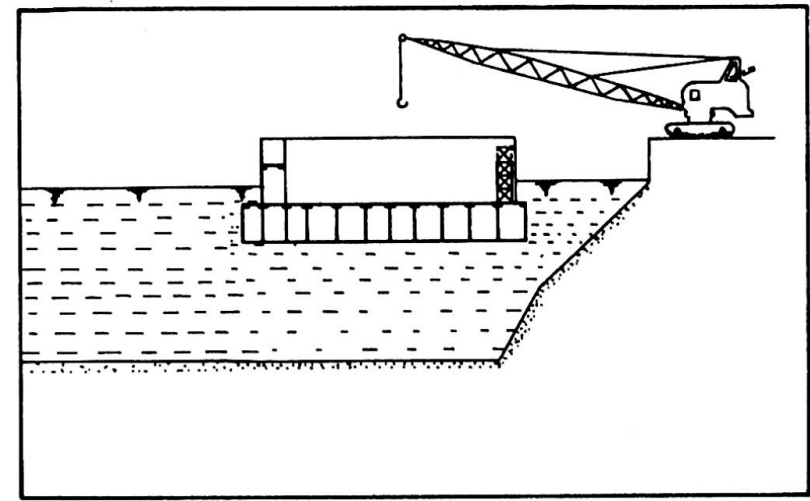

Fig. 3.b Construction in floating mode

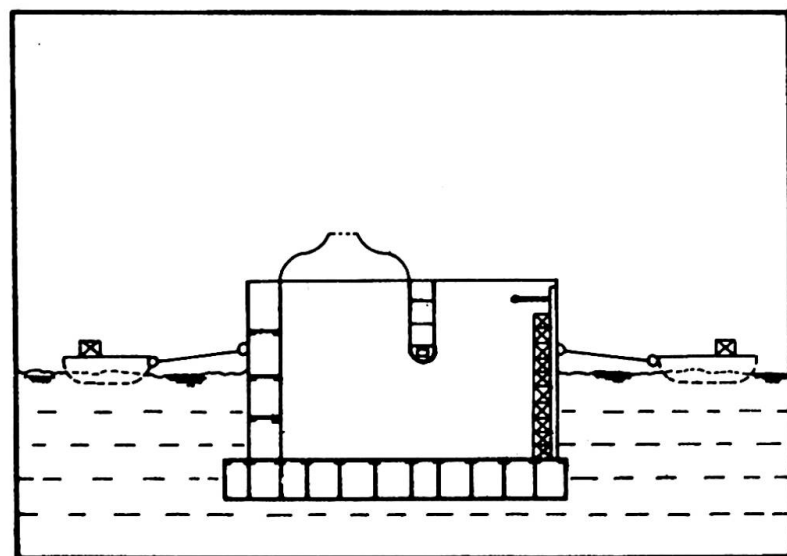

Fig. 3.c Towing

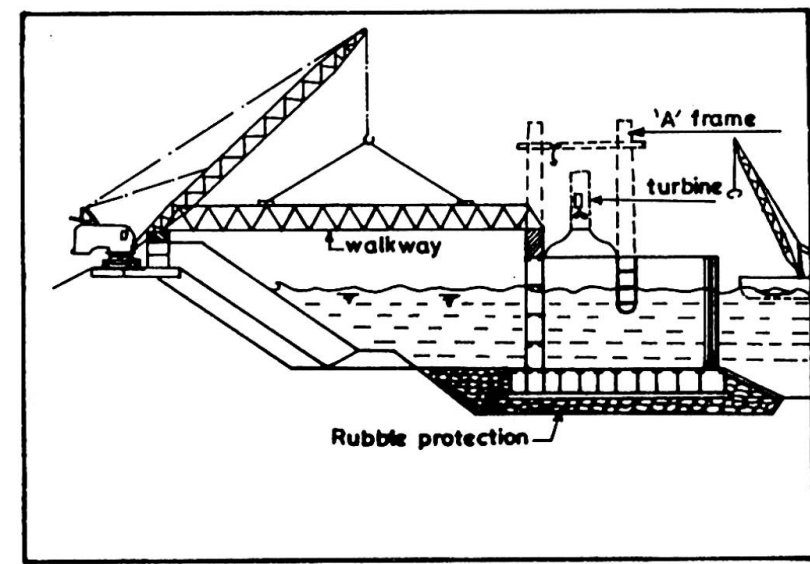

Fig. 3.d Erection of bridge



Fixed Skimmer Wall Offshore Structure Built for a Thermal Power Station

Paroi séparatrice noyée pour eau réfrigérante d'une centrale

Unterwasser-Abscheidewand für Kraftwerkskühlwasser

H.D. MATANGE
Chief Eng.
Gammon India Ltd.
Bombay, India



H.D. Matange, born in 1935, passed B.E. (Hons) from University of Baroda, India in 1956. He has to his credit several prestressed concrete bridges, high rise structures, hydraulic structures, dams etc.

SUMMARY

This paper deals with the study of an offshore structure built in the lake near Satpura Thermal Power Station in Madhya Pradesh to provide cold water for the power station from the lake. The above system is based on the principle of availability of cold water at lower depths in a lake and the lake's capacity to cool the hot water delivered from the power station due to the wind effect on the large surface area of the lake.

RÉSUMÉ

L'article présente l'étude d'une structure noyée dans le lac situé à proximité de la centrale thermique de Satpura (Madhya Pradesh), et destinée à l'alimentation en eau de réfrigération. Le principe d'une paroi à effet séparateur repose sur l'existence d'eau froide à grande profondeur dans un lac disposant d'une capacité suffisante, en vue de pouvoir refroidir l'eau chaude provenant d'une centrale électrique par échange thermique sous l'effet des vents soufflant sur une surface de lac suffisamment grande.

ZUSAMMENFASSUNG

Für die Zuleitung von Kühlwasser für das thermische Satpura-Kraftwerk (Madhya Pradesh) wurde die Lösung einer Unterwasserkonstruktion im nahegelegenen See untersucht. Die Idee einer Abscheidewand beruht auf dem Vorhandensein kalten Wassers in grösserer Seetiefe und der ausreichenden Kapazität des Sees, das eingeleitete aufgeheizte Abwasser des Kraftwerks über Wärmeaustausch mit dem über die Grosse Seefläche streichenden Wind abzukühlen.



2.00 DETAILS OF THE STRUCTURE

2.10 The structure consists of a 480.00 meter long skimmer wall, suitably designed to draw cold water from a depth of about 6 meters below the surface of the lake.

It has two rows of 49 Nos. one meter diameter piles with steel casings driven to a depth of 27.00 meters maximum and 1.00 meter depth in rock. The piles are spaced at 10 meter centres in both directions. These rows are inter-connected by suitably designed RCC bracings provided at the top of piles stiffening them in both directions.

2.20 Precast RCC planks spanning net 9.00 meter distance between the piles are erected to cover a depth of 10.274 meters from the surface of lake.

2.30 This saucer shaped structure constructed in the lake, successfully provides the required quantity of cold water to the thermal power station from the down stream end.

The hot water coming out of the thermal power station is returned to the upstream side of lake by a return canal.

3.00 LAYOUT AND CONTROLS

3.10 Survey controls

The entire structure was to be constructed in the lake and hence layout and control point establishment was important and difficult task.

3.11 As a first step two end points bench marks were established on either bank of the lake. Now the centre line of the structure was established by keeping the theodolite on the north bank and south bank base points and rotating the same by suitable angles. These new lines established the centre line of both end walls of skimmer wall. 70 meter point from North end pile and 60 meter point from South end pile established the centre line for main portion. All control points were now set to commence the work.

4.00 PROCEDURE OF CONSTRUCTION

4.10 The north side arm of the structure has 2 x 8 No. one meter diameter piles, the central section 2 x 34 Nos.piles and the southern arm had 2 x 7 Nos. of 1 meter diameter piles.

4.20

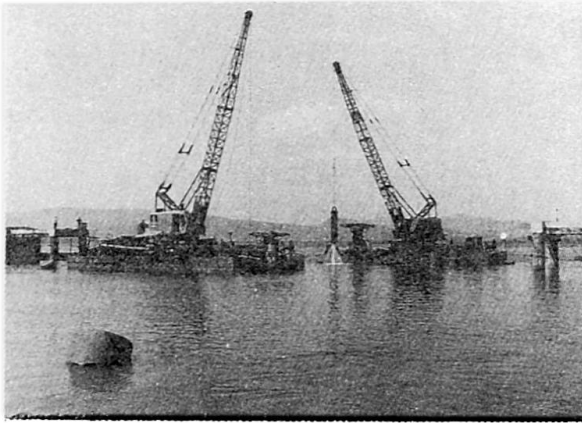

Photo.2 Hochstrasser piling rigs in operation

The Hochstrasser wisse piling rigs were mounted on a specially designed 200 MT buoyancy platforms. Each rig had one No. RB 38 or TATA P&H 955 ALC crane, bailers, chiesels, compressor, welding sets, generators, bailer stool and was totally self-sufficient. Suitable anchoring arrangements were made to maintain the rigs in any given location in the lake.

4.30



Photo.3 1000mm diameter casing being towed to site

A novel system was adopted to drive the u/s row of piles. Firstly a 1000mm diameter 12mm thick casing of approximately 10 meter length was manufactured on the bank. The ends of this casing were sealed with temperory seals and this was floated and towed to the required location near the piling rig. The casing was lifted, seal covers removed, cutting edge welded at the lower end. The upper end was connected to Hochstrasser pneumatic hammer head. The pile was now driven to final depth upto 27 meters maximum and one meter into rock.

4.31

A 1200mm diameter 12mm thick casing was now driven outside above pile, to a depth of about 8 to 10 meters to penetrate about 2 meters into clay layer. The 1000mm diameter casing and annular space between the same and 1200 diameter casing was now dewatered upto about 11 meters below water level. Excess 1000mm diameter casing upto 10.274 meters below water level was cut off.



- 4.32 A new 1000mm diameter casing, with 300 x 150 mm channels welded on either side, was lowered and placed exactly over above casing to locate above channels perfectly in longitudinal direction to enable fixing of RC planks. The lower end of this casing was now welded to the upper end of driven casing. The temporary 1200 diameter casing was now withdrawn.
- 4.33 The 1000 mm diameter pile was now dewatered and 10 Nos. 28 diameter anchors were fixed and grouted. Wherever it was not possible to dewater the pile casing for anchoring work, a M250 grade concrete bottom plug of suitable thickness (upto 2 meter thick) was laid. After allowing it to set for 21 days, the casing was dewatered and anchoring work carried out. The piles were now concreted.

5.00 The down stream piles were driven as in para 4.30.

6.00

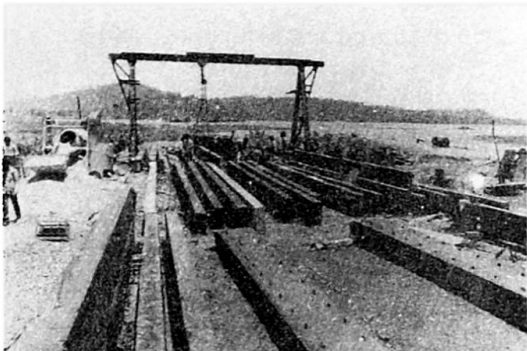

Photo.4 Casting yard for RC planks

The R.C. planks 9.20 m x 0.5 m x 0.2 m were precast in casting yard on the bank. These were floated and carried to the location with the help of two simple floats made out of 1000 mm diameter casings sealed at both ends.

6.10

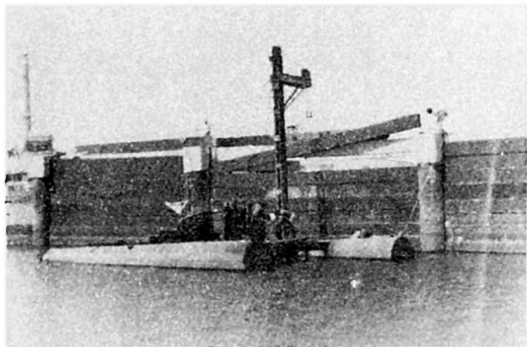

Photo.5 Launching camel placing RC planks

These planks were lifted by a launching camel and placed between the grooved piles. All R.C. planks throughout the length of the skimmer wall were fixed as above.

6.20

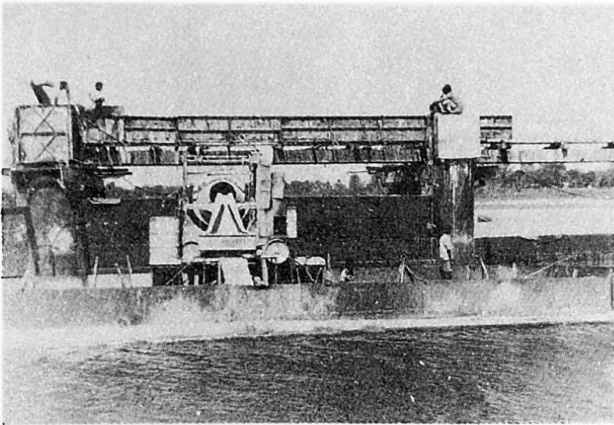

Photo 6 Concreting of cast in situ longitudinal bracings.

The longitudinal bracings for down stream piles and transverse bracing were cast in situ with suspended shutter forms.

Similarly, the top bracings above the R.C. planks were cast in situ after the R.C. planks were fixed in position

6.21 The ends of wall towards the edge of the lake have been closed with crated boulder fill at shallow depth. The entire structure was completed in 36 months.

7.00 CONCLUSION

Cooling efficiency of this structure compares favourably with induced or natural draught cooling towers. Operational cost of the system is almost "nil".

8.00 ACKNOWLEDGEMENT

The writer gratefully acknowledges the permission given by M/s. Gammon India Limited to present the above paper.

Leere Seite
Blank page
Page vide

Development of Offshore Structures — An Overview

Aperçu sur le développement des structures en mer

Entwicklung der Offshorekonstruktionen — ein Überblick

Shankare S. GOWDA
Senior Res. Scientist
Technical Research Centre
Espoo, Finland



Shankare Gowda, born 1945, received his Civil Engineering degree from the University of Mysore, India. After his Ph.D. in ocean engineering from the Memorial University of Newfoundland, Canada, he worked at the Delft University of Technology, for one year before joining VIT in 1985. His research areas are fatigue and fracture of steel structures.

Paavo HASSINEN
Senior Res. Scientist
Technical Research Centre
Espoo, Finland



Paavo Hassinen, born 1952, received his Civil Engineering degree from the Helsinki University of Technology in 1976. He currently works on the research of steel structures and bridges.

SUMMARY

With the world demand for oil, gas and coal and other minerals constantly increasing, drilling and production activities in recent years have been extending to more and more inaccessible offshore and arctic areas. Over the past few decades, the technology has changed dramatically because of the need to explore and produce in environments that were prohibitive before the 1970's. The offshore industry has witnessed a remarkable surge in the overall numbers and variety of offshore platforms throughout the world. Since the 1940s, the number of offshore platforms in the bays, gulfs, and oceans of the world today exceeds 10,000. This paper briefly reviews the advancement of offshore structures and the application of new materials used in the development of such structures.

RÉSUMÉ

La consommation de combustibles liquides, de gaz, de charbon et d'autres minéraux ayant sans cesse augmenté, il a fallu ces dernières années intensifier le forage et la production de pétrole tant en mer que dans les régions arctiques, lieux s'avérant d'un accès toujours plus difficile. La technologie de l'industrie marine a réalisé des progrès énormes pendant les dernières décennies, étant donné qu'il a fallu explorer et installer les points de production dans les lieux qui auraient été tout simplement inaccessibles avant les années 70. A partir de 1940, la gamme des plates-formes en mer s'est diversifiée et a augmenté en nombre à l'échelle mondiale. A l'heure actuelle, il y en a plus de 10,000 dispersées dans les baies, les golfes et les océans. Cette communication expose les développements des structures en mer et l'utilisation de nouveaux matériaux pour leur construction.

ZUSAMMENFASSUNG

Wegen der weltweit wachsenden Nachfrage nach Öl, Erdgas, Kohle und Mineralien dehnten sich Exploration und Produktion in den vergangenen Jahren zunehmend auf die offene See und in arktische Gebiete aus. Standortbedingungen, die bis 1970 noch undenkbar waren, führten zu einem Technologieschub mit bemerkenswertem Zuwachs der Offshore-Plattformen in Zahl und Typenvielfalt. Die Gesamtzahl der seit 1940 küstennah und -fern installierten Plattformen übersteigt bereits 10.000. Der folgende Beitrag versucht eine kurze Zusammenschau der unter Einsatz neuer Werkstoffe erzielten Fortschritte.



1. INTRODUCTION

As oil and gas exploration activities moves into more deeper and harsher waters of offshore and arctic areas, new class of structures are becoming increasingly important. During 1940's to 1960's, steel structures were common. The steel templates or jackets which were fabricated onshore and then carried to the site by barge and lowered into the water. When in position, they are fixed to the bottom using steel piles driven through the jacket legs. However, the decade of the 1970s witnessed a remarkable surge in the numbers of offshore platforms. The evolution of many platform designs since 1940's is shown in Fig. 1. Offshore structures are universally designed for functional purposes based on rational and empirical design and the whole is judged primarily on economic grounds. The design and construction of an offshore platform involves many related and interdependent endeavors and include many technologies such as, oceanographic engineering, foundation engineering, structural engineering, marine civil engineering and naval architecture.

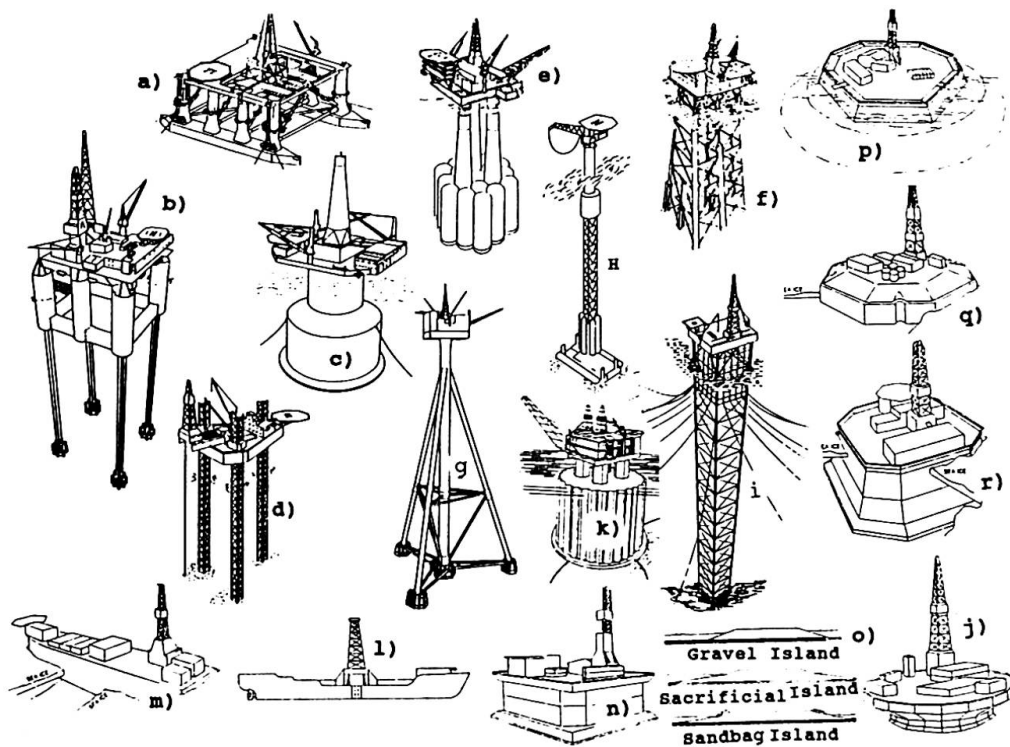

Fig. 1 Selected offshore structures: a) semi-submersible platform; b) tension leg platform; c) buoy-type; d) jack-up; e) gravity platform; f) jacket-type; g) steel tripod; h) articulated tower; i) guyed tower; j) steel caisson; k) GBS platform; l) drillship; m) single steel drilling caisson; n - r) arctic structures /1, 10/.

Over the past 30 years, numerous categories of offshore platforms have been evolved, which can be classified into four major groups: steel jacket-type structures, concrete structures, arctic structures and compliant platforms. The type of structure to be used for a particular application depends to a large extent on the intended use, the conditions at site, water depth and weather conditions. The fabrication and installation of an offshore platform is a specialized task. The whole structure is designed taking into consideration, the total weight of topside facilities and environmental loads. Offshore structures are subjected to large gravity loads and cyclic environmental forces besides corrosion and fouling. The pictorial summary of major loads, environmental forces and corrosion zones at different depths in a typical offshore platform is shown in Fig. 2.

Because of the possibility of miscalculations in the determination of applied loads for offshore structures due to interpretation of fluctuating environmental conditions, safety factors are used in accordance with the principles of limit state design. The estimation of vertical loads on platforms, which are primarily dead loads, can be estimated with reasonable accuracy but the greater uncer-

tainty is involved in the horizontal loads. In general, the magnitude of the horizontal loads vary for about 15 - 35 % of the vertical loads /2/.

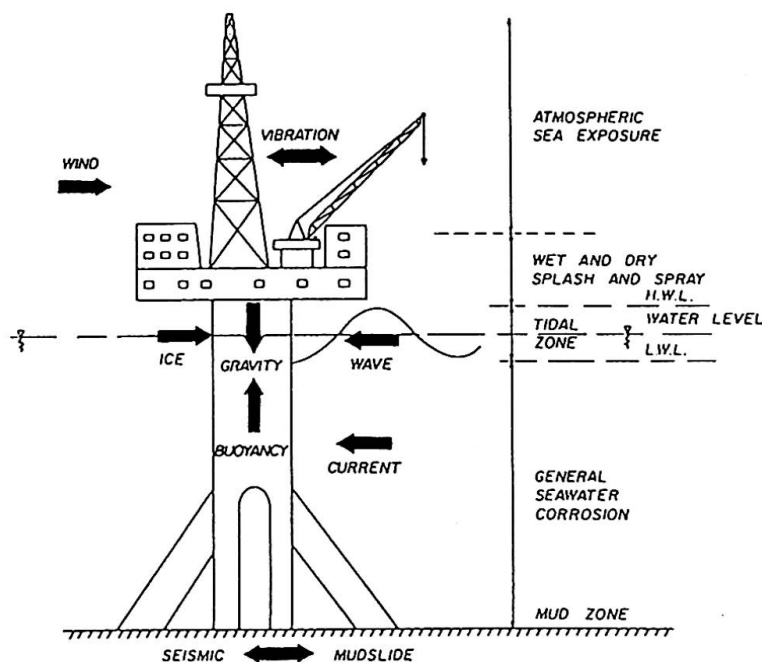

Fig. 2 Major platform loads and corrosion zones.

2. REVIEW OF STEEL, CONCRETE, COMPLIANT AND ARCTIC STRUCTURES

Steel Structures: The installation of the first template or jacket type steel structure in the Gulf of Mexico, off the Louisiana coast in 1947 at a water depth of 6 m, marked the first use of welded tubular offshore platform. Since then the offshore industry has seen the evolution of many platform designs (Fig. 3). Presently, over 3,700 offshore steel platforms are operational worldwide with the predominant locations being the Gulf of Mexico, the North Sea, and the Arctic. The majority of offshore structures are steel structures consisting of welded tubular members welded together. The reason for their popularity is due to the fact, that they possess excellent strength properties and offer minimum exposed area to wind and wave forces. They also exhibit omni-directional strength with design flexibility, greater economy in mass and possess better hydrodynamic properties. The world's tallest steel platform at present is the Bullwinkle platform (Fig. 3), installed in the Gulf of Mexico in 1988. It has a height of 492 m and weighs more than 71,000t and has a base measuring 122 by 146 m /3/.

Concrete Structures: During the 1970s, a second generation of offshore structures have been evolved. The North Sea oil exploration sparked the idea for concrete deepwater platforms (CONDEEPS) /Fig. 1, c & e/. These concrete gravity structures rest directly on the ocean floor by virtue of their own massive weight. In the early stages, they are constructed onshore or in sheltered waters, then towed in semisubmerged position to the site and installed in position by ballasting. The size of the concrete structure vary depending on the design. The base diameter range from 52 m to 169 m, while the column diameter may vary from 15 - 30 m. Since the first Ekofisk platform installation in 1973 at a water depth of 70 m, more than 20 concrete platforms have been installed in the North Sea. The recent tallest concrete platform to be installed in the North Sea in 1990s is the concrete tripod platform (Fig. 3) for the Troll field at a water depth of 335 m. It requires about 750,000t of concrete and has a payload capacity of 60,000t /5/. Apart from the North Sea concrete structures, is the Hibernia concrete gravity based structure (GBS) planned for offshore Newfoundland for a water depth of 80 m. This GBS platform will have a diameter of 105 m and a height of 148 m (Fig. 1k), with a concrete volume of 60,000 cu.m. and steel weight of 59,400t. The total weight of the structure when completed will be 1,025,000t. This massive structure is designed



to resist the impact exerted by the moving icebergs with an average mass in the range of 30,000 to 60,000t /6/.

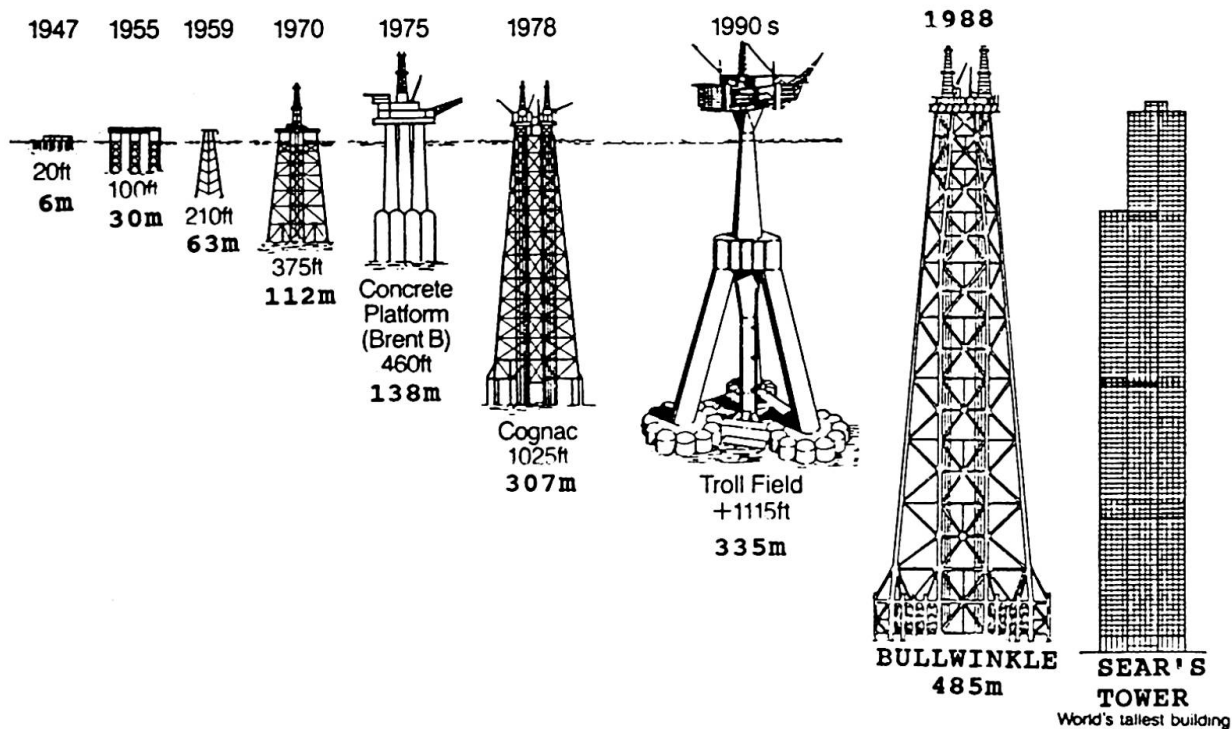

Fig. 3 Evolution of offshore platform design /4/.

Compliant Platforms: As the water depth increases, the use of jacket-type and concrete platforms becomes unacceptable because of high increase in weight and costs. In such situations, a new class of structures, namely the "compliant platforms" (Fig. 1 b, h & i), is likely to become increasingly important. Prominent new examples of this type of structures are the tension leg platform (TLP), articulated column, the guyed tower, and the semi-submersible. The principal characteristic of these structures that distinguishes them from the more traditional fixed jacket-type structure is that they more or less ride with the waves rather than resist them. Hence, the name compliant. The advantages of these compliant structures is that they can have excursions with extreme values of the order of several meters. In addition, as the water depth increases, the traditional fixed jacket-type structures become extremely costly as can be seen in Fig. 4 /8/, while tension leg platforms offer many advantages with regard to safety and cost reduction. For example, the tension leg well platform (TLWP) requires only 5,000t of steel compared with 50,000t for a fixed platform for a water depth of 533 m. The TLWP carries only wellheads and related equipment, while process equipment and accommodation would be on a tanker moored permanently few kilometers away from the structure /4/.

Arctic Structures: The new discoveries of vast reserves of oil and gas in the ice-infested waters of Alaska and the Canadian Beaufort Seas in the late 1960's and early 1970's, led to the development of new generations of arctic structures for these areas /Fig. 1(m - r)/. Offshore exploration and production structures for the high arctic can be divided into two categories: bottom-founded and floating. The bottom-founded structures can be further divided into five types, namely, 1) artificial "fill" islands, 2) caisson retained islands, 3) caissons, 4) cones and monocones, and 5) monopods and monoleg jackups. These shallow water arctic structures (20 - 45 m) must be designed to operate safely under design requirements (winter and open water seasons) and survive extreme conditions without catastrophic consequences. They have to operate at temperatures as low as - 50 °C, and with a 95 kph wind chill factor it can drop to -110 °C. In addition, the structures have to resist ice forces from multi-year ice with thicknesses ranging from 5 to 7 m. The operating costs of arctic structures are believed to exceed \$600,000 per day /9/.

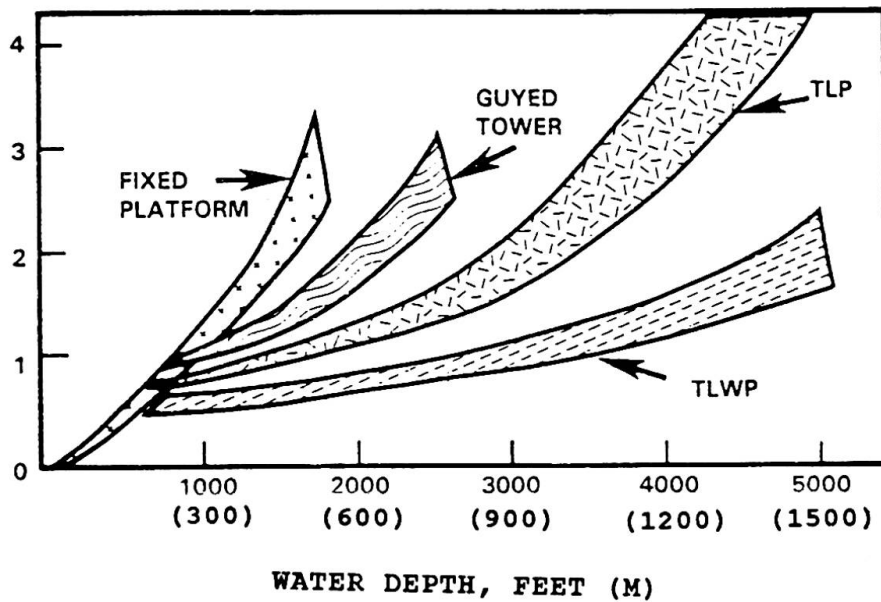

Fig. 4 Relative cost for field development (Gulf of Mexico) /8/.

3. APPLICATION OF NEW MATERIALS

Offshore structures are subjected to cold temperatures, ice forces, strong winds, high waves and extremely corrosive conditions than in the case of land based structures. Because of the low performance of traditional steel and concrete material in extreme offshore conditions, a number of so-called new uncommon materials are emerging in the offshore industry. These include, high alloy stainless steel, high-strength steel, high-strength concrete, light-weight concrete, aluminum, fiber reinforced superalloy composite materials, new coating materials etc. These new materials have the vast potential for weight and cost savings. According to Alcan Offshore Co., the use of aluminum rather than steel in accommodation modules, helidecks and other units of offshore structures can offer up to 40 - 70 % weight savings.

Higher strength steels (HSS) are currently finding increasing demand because of improved welding procedures. HSS having tensile strength in the range of 550 - 785 N/mm² (Y.S. = 460 N/mm²) and higher are replacing the traditional steel having T.S. 490 - 640 N/mm² (Y.S. 355 N/mm²).

New polyethylene and polyurethane coating materials for steel piles and pipes are finding increasing use in marine applications. They are used to protect against corrosion, wear and adfreezing effects. The technical and economical advantages of composite materials made of epoxy and glass-fiber for pipes and other subsea offshore systems are on the increasing demand in recent years.

The use of high-strength light-weight aggregate concrete in marine structures is highly attractive because of many advantages. Programs to develop light-weight concrete having compressive (cylinder) strength ranging from 50 - 60 MPa, with densities 1920-2080 kg/cu.m. are under progress. The better quality high-strength concrete having compressive strength more than 100 MPa for cold region applications are also under development in many countries.

In the case of arctic and massive gravity-based structures, the use of sandwich steel/concrete composite construction has a potential for cost savings. The basic composite system consists of two thin continuous steel plates, placed concentrically with a filler material such as concrete between them. Composite members exhibit high flexural and shear capacity with very ductile failure and a large capacity to absorb energy. To further increase the load carrying capacity of composite structures, different materials, such as steel studs, steel fibres, bar shear reinforcements and high-strength steel and stainless steel are used. Some experimental tests on 18 such steel/concrete composite structures have been carried out at VTT and a significant difference in load carrying capacity was noticed among different specimens. Fig. 5 shows the load-deformation behaviour of composite members with some different combination of materials.

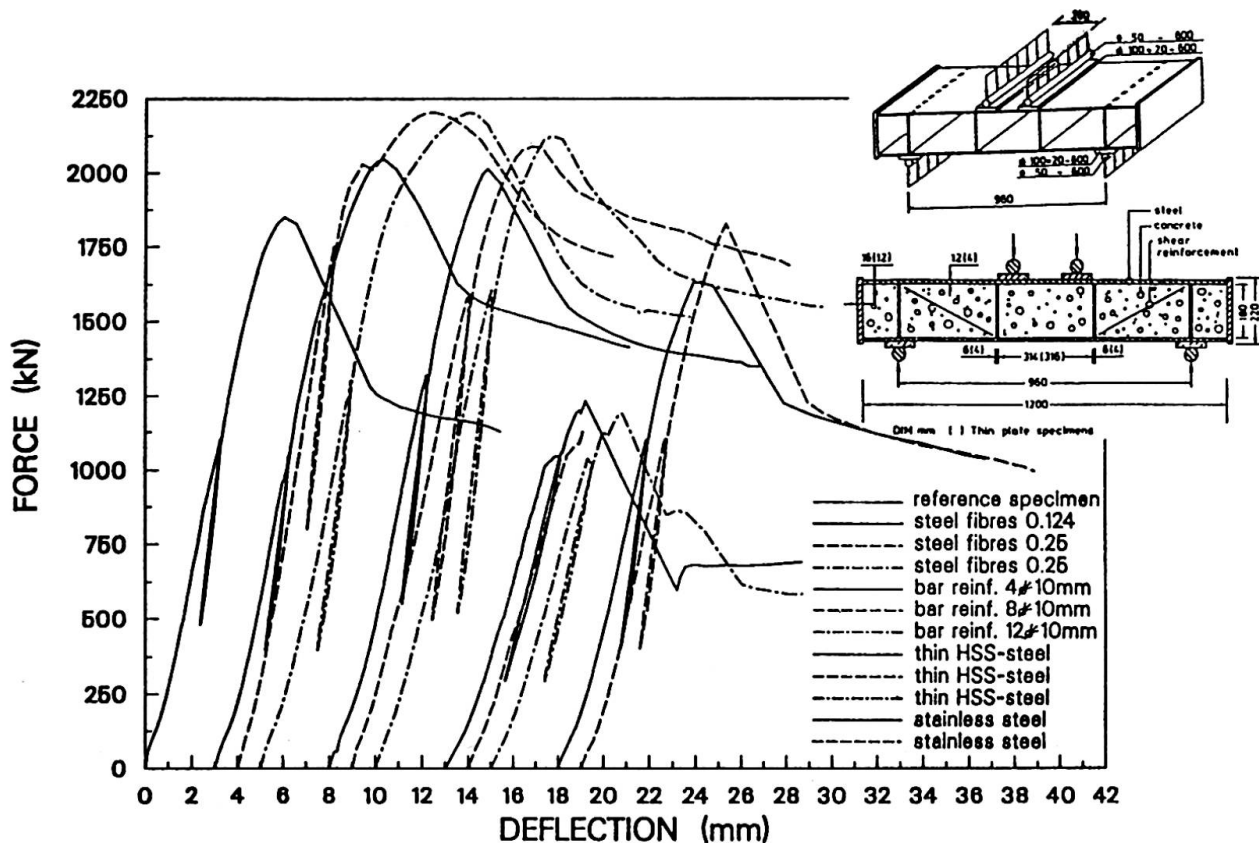

Fig. 5 Load-deformation behaviour of some different steel/concrete composite specimens.

5. CONCLUDING REMARKS

The ever increasing demands of oil and gas and the involvement of the offshore industry, contributed to many outstanding achievements and technical breakthroughs in the field of offshore engineering. Despite the current economic uncertainties, the development outlook for offshore, the arctic and sub-arctic regions will probably continue, but with a slower steps than planned. New generation of production structures for water depths deeper than 1000 m and for the high arctic regions are still technological challenges facing the engineers. In this regard, the new technologies and the development of new materials, material combinations and structural systems for offshore applications will play an important role in the future.

REFERENCE

1. Almar-Naess, A. Fatigue Handbook, Tapir Publications, 1985.
2. Graff, W. J., Introduction to Offshore Structures - Design and fabrication, Gulf Publishing Co., Houston, 1981.
3. Ocean Industry, July 1985.
4. Offshore Engineer, April 1985.
5. Troll - The story so far. Offshore Engineer, December 1983.
6. The Oilman, April 1991.
8. Langewis, C., Offshore Outlook. Conoco Inc., 1986.
9. Offshore Engineer, December 1984.
10. Kelly, P.L., U.S. Offshore Development in Bering and Beaufort Seas, Polartech'86, 1986.