

Teach-in 1: Structural concrete: concepts and practices

Objektyp: **Group**

Zeitschrift: **IABSE congress report = Rapport du congrès AIPC = IVBH
Kongressbericht**

Band (Jahr): **14 (1992)**

PDF erstellt am: **26.09.2024**

Nutzungsbedingungen

Die ETH-Bibliothek ist Anbieterin der digitalisierten Zeitschriften. Sie besitzt keine Urheberrechte an den Inhalten der Zeitschriften. Die Rechte liegen in der Regel bei den Herausgebern.

Die auf der Plattform e-periodica veröffentlichten Dokumente stehen für nicht-kommerzielle Zwecke in Lehre und Forschung sowie für die private Nutzung frei zur Verfügung. Einzelne Dateien oder Ausdrucke aus diesem Angebot können zusammen mit diesen Nutzungsbedingungen und den korrekten Herkunftsbezeichnungen weitergegeben werden.

Das Veröffentlichen von Bildern in Print- und Online-Publikationen ist nur mit vorheriger Genehmigung der Rechteinhaber erlaubt. Die systematische Speicherung von Teilen des elektronischen Angebots auf anderen Servern bedarf ebenfalls des schriftlichen Einverständnisses der Rechteinhaber.

Haftungsausschluss

Alle Angaben erfolgen ohne Gewähr für Vollständigkeit oder Richtigkeit. Es wird keine Haftung übernommen für Schäden durch die Verwendung von Informationen aus diesem Online-Angebot oder durch das Fehlen von Informationen. Dies gilt auch für Inhalte Dritter, die über dieses Angebot zugänglich sind.



Teach-In 1

Structural Concrete: Concepts and Practices

Structures en béton: concepts et applications

Betonbau: Kozepte und Anwendungen

Organiser: Jorg Schlaich
Germany

Leere Seite
Blank page
Page vide



**TEACH IN
STRUCTURAL CONCRETE**

**J.E. Breen
The University of Texas at Austin**

Presented by

**L. Wyllie
Degenkolb and Associates**

**March 2, 1992
New Delhi**



In this Introductory section of today's Teach-In on Structural Concrete, we wanted to explain why IABSE, and particularly Working Commission III, Concrete Structures, is leading an international effort to refocus our approach to design of concrete structures.

Indeed -- Why Structural Concrete?

After all, Reinforced Concrete is well over 100 years old and Prestressed Concrete is now over 50 years old.

We have shown that we can build truly beautiful structures

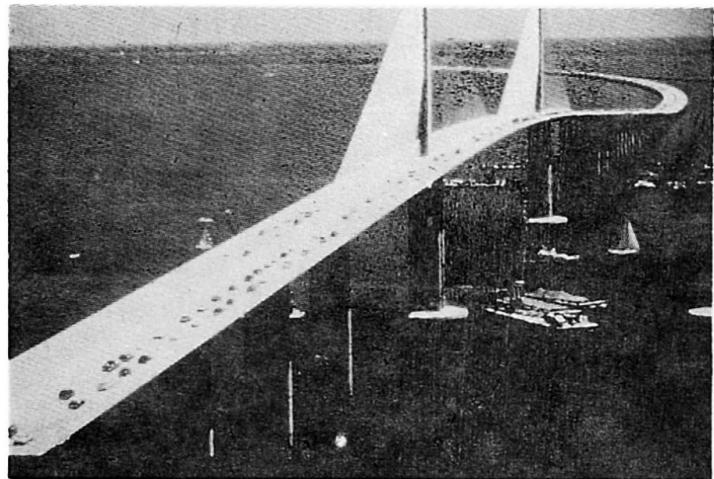
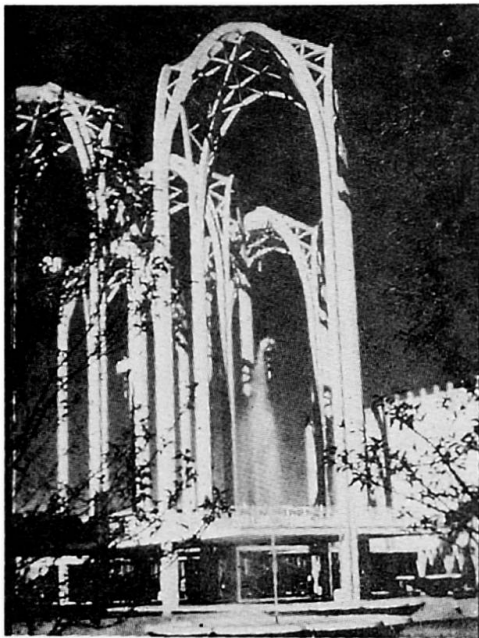

and breathtaking bridges -- monuments that any age would envy.

In view of this well-developed industry and the impressive knowledge base which surrounds it --

- Why do we want to re-examine fundamental approaches?
- Why is there any urgency to do it now?

Structural concrete is definitely a world-wide industry. Projects frequently cross continental lines producing an increased need for harmonization. Today's communication explosion creates global interaction. Engineers in one country frequently work on projects a continent away with totally different codes and standards.



The lack of harmonization is particularly apparent when the project includes prestressed concrete. While CEB and FIP have collaborated in an impressive way, the world-wide status is still disturbing.

There is an absence of an overall unifying approach which smoothly meshes reinforced and prestressed concrete. The fragmentation is obvious in technical societies in countries such as the USA where we even have one professional group for pretensioners and a completely different one for post-tensioners. It is mirrored by serious divisions in education and textbooks for reinforced concrete and for prestressed concrete.

The complaints of many designers working in many lands led Working Commission III to become conscious of the growing frustration of code users with our man-made fragmentation. We decided that the time to unify Structural Concrete is now. We had a most successful colloquium in Stuttgart in April 1991 where it became apparent that the feeling was world-wide. We hope that the results and the summary statement from the Stuttgart Colloquium will spark other organizations to act.

During this Teach-In we want all of you to focus on the advantages of a consistent approach to reinforced and prestressed concrete in both education and practice. In the talks that follow we will be focusing on a design approach that gives major focus to overall structural behavior and flow of forces throughout the structure. It will reacquaint you with useful and highly transparent models.

We want to, wherever possible, eliminate conflicts in codes and standards.

Concrete does not stand alone -- in each country structural engineers must develop an overall framework to facilitate mixed or composite construction.

In order to communicate our ideas, we suggest a few definitions.

The most basic is the term "Structural Concrete." We ask that this term be used for the entire spectrum of concrete used for structural purposes from non-reinforced applications through applications which have a mix of non-prestressed and prestressed reinforcement.

Another useful term is "active reinforcement" or some may prefer the term "prestressed reinforcement". Note we consider only that portion of the reinforcement capacity developed by the construction operations as "active."

The complementary term is "passive reinforcement" or some may prefer the term "non-prestressed reinforcement." Note that this includes that portion of the active reinforcement capacity which is not developed during prestressing operations. This is the stress increase above the effective prestress level developed in bonded tendons as they resist higher levels of applied load.

It is very convenient to think of prestressing as a load type action applied by the constructor which are additive to other loads. These loads, including their axial and normal components and eccentricities, can be entered into the analysis and combined with other loads. The final effect must be countered by the resistance.



ACTIVE REINFORCEMENT

- Any reinforcement which is mechanically, electrically, or chemically stressed by constructor controlled methods during the construction process
- Only that portion of the active reinforcement capacity which is developed by the construction operations

PASSIVE REINFORCEMENT

- Any reinforcement which is not actively stressed by constructor controlled methods in the construction process
- Includes the developable capacity of active reinforcement in excess of that developed during the construction process

SUPERFLUOUS TERMINOLOGY

- Fully prestressed concrete
- Partially prestressed concrete
- Reinforced concrete
- Secondary moments or Parasitic moments

USEFUL TECHNICAL TERMINOLOGY

- Pre-tensioning
- Post-tensioning
- Internal tendons
- External tendons
- Bonded reinforcement
- Unbonded reinforcement
- Precast concrete
- Cast-in-situ concrete

By the use of these definitions it becomes unnecessary to use some terms which cause considerable confusion such as fully prestressed concrete and partially prestressed concrete. Prestressed concrete members all have both active and passive reinforcement. Thus, prestressed concrete members are also reinforced concrete although we usually use that term to imply non-prestressed concrete. Using "Structural Concrete" eliminates these artificial distinctions.

One of the main advantages in considering prestressing as a load is that calculations of secondary moments becomes de-mystified and their redistribution more obvious. All that is required is a conventional analysis which correctly considers boundary conditions, restraints, and realistic stiffnesses.

Many traditional technical terms continue to be useful but do not require separate codes, standards or design procedures.

It is amazing that constructors have little difficulty in treating all of the various forms of structural concrete in a unified way while we designers often run into artificial discontinuities in theories, approaches, codes and standards.

Both designers and constructors conquer these man-imposed obstacles in their battles with the forces of gravity and nature. Why do we make life so hard for ourselves in the design process?

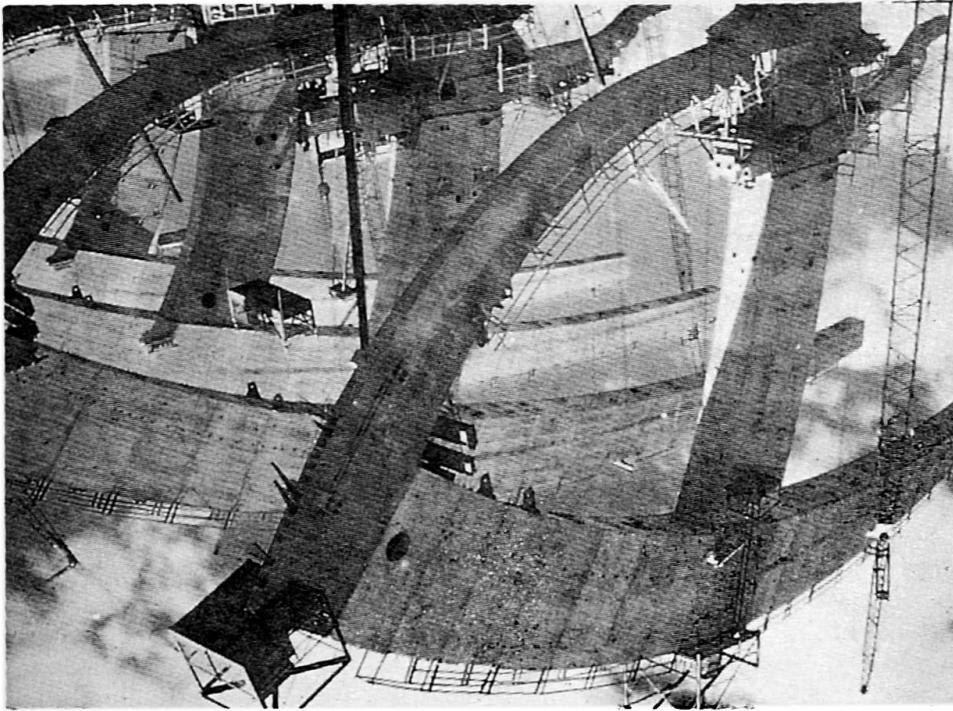

So that you may better understand WCIII concerns, we have outlined a few inconsistencies drawn heavily from a North American perspective, but found to be fairly representative.

In spite of the rapidly growing use of prestressed concrete construction in the USA, most American universities either do not teach a course on reinforced concrete or restrict such courses to graduate students.

Our separate treatment of "reinforced concrete" and "prestressed concrete" in university courses and in textbooks gives the newcomer the false impression that these are fundamental differences between the subjects.

It is not only the universities that are divided -- Many countries have separate standards for "reinforced concrete" and "prestressed concrete." Often these separate standards have conflicting notation. Totally different approaches are used to express the same fundamental principles -- Approaches lack transparency and abound in confusing empirical equations. The variety of overlapping codes and standards is breeding errors rather than minimizing them.

When a country has completely separate standards for reinforced concrete and for prestressed concrete, it becomes very difficult to decide questions such as the proper degree of restraint which these prestressed slabs provide for the non-prestressed columns. Modern designers live in a mixed world!



CODES AND STANDARDS

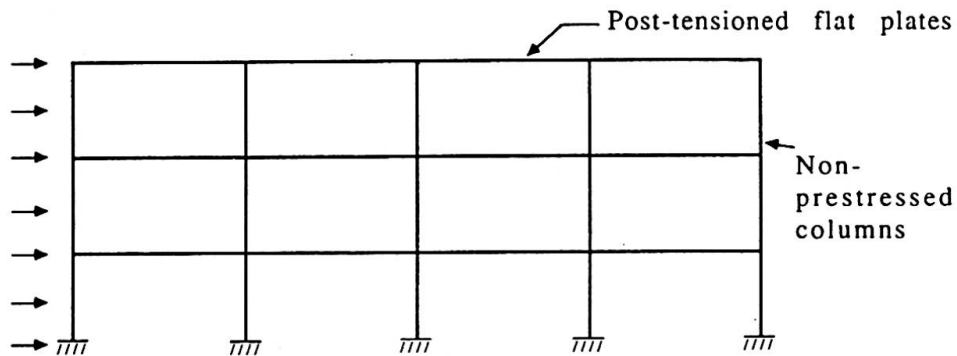

A universal complain is that codes and standards are becoming increasingly complex as they blindly adopt excellent "research models" instead of transparent, designer-friendly models which we will emphasize today. Innovation is limited by the narrowness of the empirical models.

Numerous structures have experienced substantial distress and structural failure due to poor detailing induced by the lack of overall consideration of the flow of forces and the restraints active in the structure.

An ugly example is this office building for a major engineering company. Structural engineers employed by the company frequently visited the construction site to see their new offices growing.

The building was virtually complete - the electricians incorrectly wired a 3-phase electric motor. They turned on the power - a small motor on the roof surged - the entire building collapsed with a number of workmen killed.

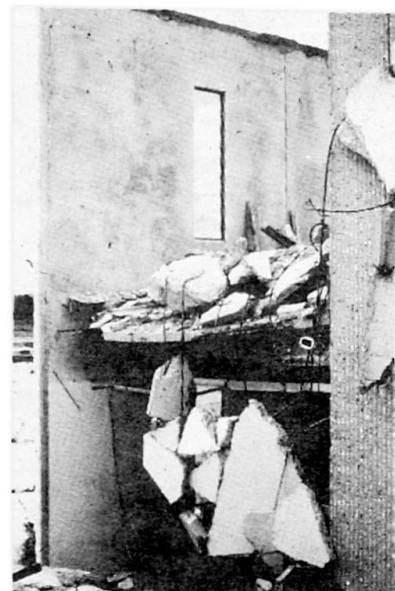
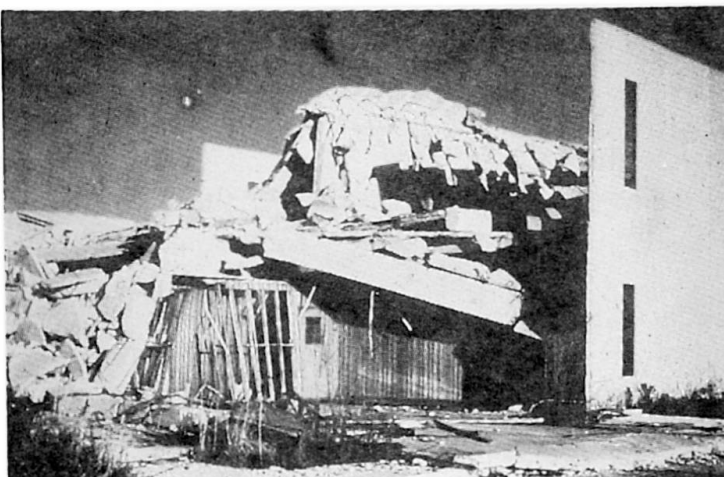

The tilt-up prestressed walls and the cast-in-situ post-tensioned beams were correctly proportioned in terms of section-by-section analyses. No thought or attention was given to tying the various members together. The beams had no supports under their ends and were rubbing by friction on the walls -- when friction was broken, the building collapsed.

Minimal attention to force paths would have saved lives and property.

Another example of poor detailing due to lack of consideration of applied loads and force paths was shown in a major curved bridge.

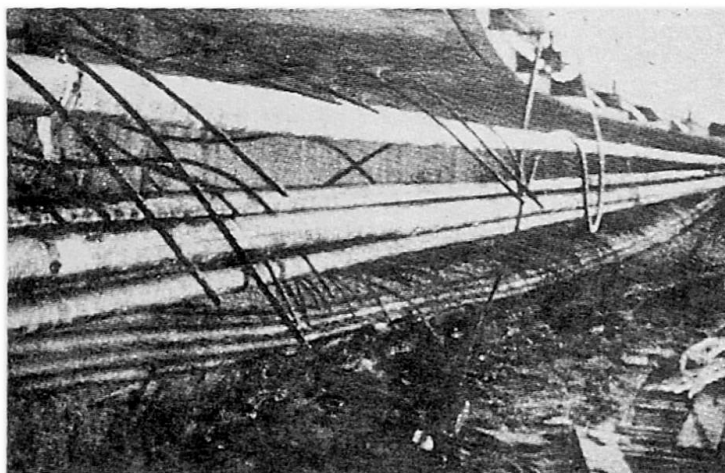

No tie-back reinforcement and inadequate cover was present to equilibrate out-of-plane forces when the tendons were stressed -- the arc became a chord. Again, minimal attention to good detailing and force paths would have prevented their collapse.

The primary tools required to implement a consistent structural concrete methodology need to be highly transparent and design-oriented such as the Strut-and-Tie Models. Tools like interactive graphic programs and finite element analysis can be useful if they are used to help with force paths and not as strictly numerical output.

In this session today we hope that we can bring to this great Indian sub-continent our version of what a consistent and transparent design philosophy can do.

Our challenge today is to help you move towards unity, simplicity and clarity in your approach to Structural Concrete.

Leere Seite
Blank page
Page vide

Strut-and-Tie Model Design of Structural Concrete

Analogie du treillis dans les structures en béton

Stabwerkmodelle für Konstruktionsbeton

Jörg SCHLAICH
Prof.. Dr.
Univ. of Stuttgart
Stuttgart, Germany



Jörg Schlaich, Professor and Director of the Inst. for Structural Design, at the Univ. of Stuttgart and Consulting Engineer with Schlaich Bergemann and Partner, Stuttgart.

SUMMARY

Only through an intelligent model can a complex reality become translucent and understandable to a designer and there lies the key to quality in structural engineering. Strut-and-tie models can illustrate very well the internal flow of forces in structural concrete and thereby, provide valuable assistance to the designer who is striving for an appropriate and functional conceptual design. Moreover, such models are good enough to serve as a basis for the design and dimensioning of the modelled structure or structural detail for the cracked state.

RÉSUMÉ

Une réalité complexe ne peut être comprise qu'à travers un modèle cohérent et intelligible; pour l'ingénieur ceci est la clef d'un dimensionnement efficace particulièrement dans le domaine des structures. L'analogie du treillis permet de visualiser de façon très claire le cheminement des forces dans les structures en béton; ceci constitue une aide précieuse pour l'ingénieur lors du dimensionnement approprié d'éléments porteurs ainsi que des détails de construction. De plus, de tels modèles représentent le fondement du calcul des constructions en béton armé et précontraint à l'état fissuré.

ZUSAMMENFASSUNG

Weil man nur bearbeiten kann, was man versteht, ist die Wahl eines intelligenten Modells, das ein komplexes Tragwerk durchsichtig und verständlich macht, der Schlüssel zur Qualität im Konstruktiven Ingenieurbau. Mit Stabwerksmodellen kann der innere Kraftfluß sehr anschaulich dargestellt werden. Dadurch sind sie auch eine wertvolle Hilfe für den Entwurf zweckmäßiger Tragwerke und Details. Sie sind außerdem eine geeignete Grundlage für die Bemessung von Stahl- und Spannbetonkonstruktionen im gerissenen Zustand II.



1. INTRODUCTION

Breen [1] proclaimed at the IABSE Colloquium: 'Structural Concrete' in Stuttgart "useful and transparent models, which can enhance the designer's realization of structural action" and he emphasized several times strut-and-tie models (STM) as such a tool. Beginning with Ritter's truss model for beams such models were used for the visualization of forces in some specific cracked reinforced concrete elements and for proportioning their reinforcement. Thürlimann and his Zürich School developed a more general design concept using stress fields on the basis of theory of plasticity. More recently Schlaich and his co-workers proposed to generalize the strut-and-tie method for the application to all kinds of structural concrete elements or structural details and to compliment the method by a unified concept for the dimensioning of cracked structural concrete, including the node regions of struts and ties [2, 3, 4].

Such a concept is urgently needed considering the Codes of Practise, which give design rules only for elements with linear strain distribution (B-regions) but neglect all others, more complicated ones, where damage most frequently occurs. The lack of a consistent methodical approach for the design and dimensioning of such discontinuity regions (D-regions) is felt particularly when they are taught to the students. Considering the importance of the D-regions for the safety and endurance of structures their design cannot be left to the draftsman's skill or the engineer's good guess. Any rational approximate method is better than this state of dimensioning.

2. MODELS FOR STRUCTURES CONSISTING SUBSTANTIALLY OF B-REGIONS BEAMS, FRAMES AND ARCHES

This concerns the majority of the daily building activity (even more if we include the slabs, see sect. 4). Though these structures consist widely of B-regions (fig. 1 shows a typical example) they only in very rare cases can do without any D-regions.

In B-regions the Bernoulli-hypothesis of plain strain distribution is valid (B stand for beam or Bernoulli). Their internal state of stress is easily derived from the sectional forces (bending and torsional moments, shear and axial forces) through clearly defined models as discussed below.

Regions in which the strain distribution already for a linear-elastic stress-strain law is significantly non-linear due to static (e.g. concentrated loads) or geometric (e.g. corners, bends, openings) discontinuities are called D-regions (where D stands for discontinuity, disturbance or detail).

Of course, it would be unreasonable to begin immediately to model these structures with strut-and-tie-models (STM) or even with finite elements. Rather the common practice should be maintained to model the real structure by its statical system, i.e. one-dimensional elements following the center lines of the real sections, and to analyse its support reactions and sectional effects, the bending moments (M), normal forces (N) shear forces (V) and torsional moments (T). It should be emphasized, that this analysis in cases of structures with predominant B-regions such as in fig.1 yields satisfactory results for the deformations and forces if it is carried through the D-regions even, i.e. if even the D-regions are for that purpose treated as B-regions - but only for this overall analysis, not for the dimensioning of the D-regions themselves! In cases of doubts, i.e. if the D-regions appear to dominate against the B-regions, the method described in sect. 3 should be followed.

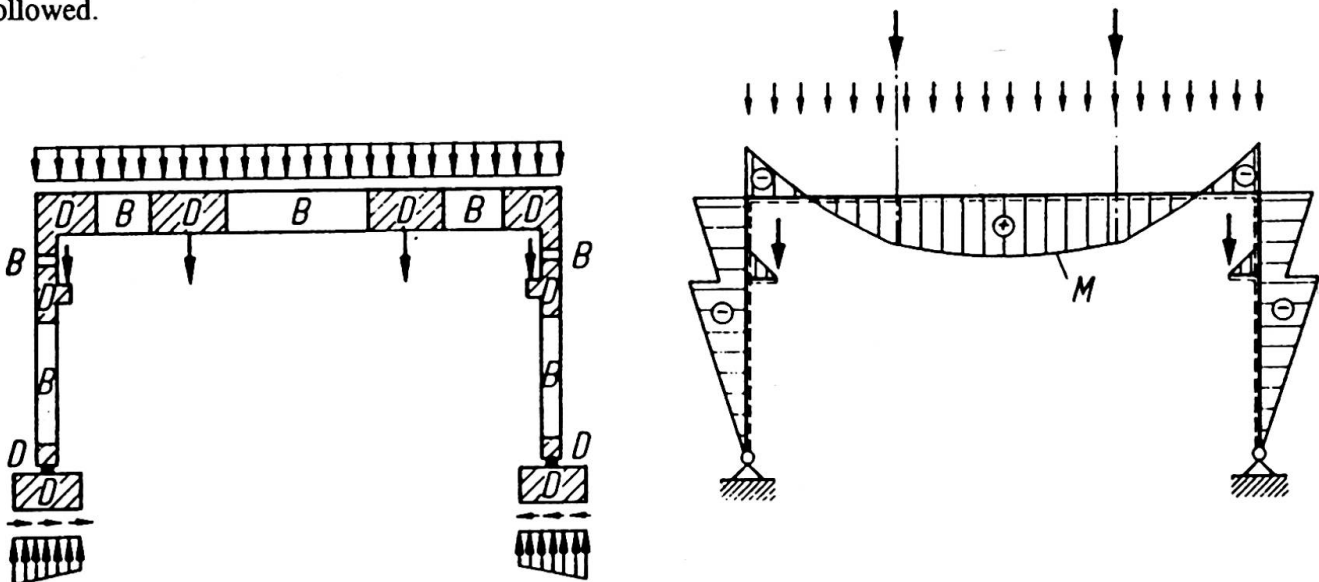

Fig. 1: A frame structure containing a substantial part of B-regions, its statical system and its bending moments.

As already mentioned, for calculating the deformations and, in case of a statical indeterminate structure, the sectional effects, one will certainly start applying sectional values (bending stiffness EI, torsional stiffness GI_t , axial stiffness EA etc.) on linear-elastic basis.

If the sectional forces are known the dimensioning of the B-regions, especially of their reinforcement may follow standard procedures. As long as a section is uncracked (e.g. in columns or due to prestress), the inner forces are calculated with the help of section properties like cross sectional areas and moments of inertia. If the tensile stresses exceed the tensile strength of the concrete the truss model ¹ applies (fig. 2). Since for B-regions with light transverse reinforcement, the truss model yields unrealistic low inclinations for the struts, efforts have been made to explain the mechanical meaning of the V-term, applied for correction by several codes, because the inclined compression chord explanation can apply only to D-regions. It has been shown, that by considering the concrete tensile strength it is possible to model the load bearing behaviour of the webs of a B-region consistently /5/.

The overall analysis and the B-regions dimensioning provide also the boundary forces for the D-regions of the same structure. As long as the D-regions are uncracked, they can be readily dimensioned and analyzed by standard procedures including finite elements analysis (FEA) applying Hooke's law. If they are cracked the STM design has to be applied for dimensioning /2,3,4,6/. For finding the geometry of the strut-and-tie-models especially for unusual cases, an elastic analysis on FE basis is helpful (Table 1). The loadpath method supports the finding of the model geometry and trains the designer's understanding of the flow of inner forces. However, the number of D-region types for beams and frames is rather limited and the experienced designer will soon be able to rely on his STM-collection. Efforts are being made to provide practice with a reliable collection of such cases (further comments on D-regions see sect. 3).

For later improvement and review and with the real dimensions and reinforcement in hand, it may be necessary to repeat the analysis using non-linear moment-curvature relations. This will become a must for structures with strongly geometrically non-linear behaviour, with theory of second order effects or in case of buckling problems. Fortunately there are handy computer programs available today for that purpose.

It must indeed be warmly welcomed, that most instability problems can today be solved by a theory of second order analysis on basis of imperfections, whose assumption poses no problem to the experienced designer.

Table 1: Analysis leading to stresses or strut-and-tie-forces.

Structure Analysis		Structure consisting of:		
		B- and D-regions e.g., linear structures, slabs and shells		D-regions only e.g., deep beams
		B-regions	D-regions	D-regions
Overall structural analysis (Table 3) gives:		Sectional effects M, N, V, M _T	Boundary forces:	
			Sectional effects	Support reactions
Analysis of inner forces or stresses in individual regions	State I (uncracked)	Via sectional values A, J _B , J _T	Linear elastic analysis* (with redistributed stress peaks)	
	State II (cracked)	Strut-and-tie-models and/or nonlinear stress analysis *		
		Usually truss		

* May be combined with overall analysis

1 . Here the expression truss model is used to define the special application of the general STM to B-regions. A truss has compression and tension chords parallel to the surface lines, inclined struts or compressive stress fields and transversal ties representing the stirrup reinforcement and/or tensile stress fields.

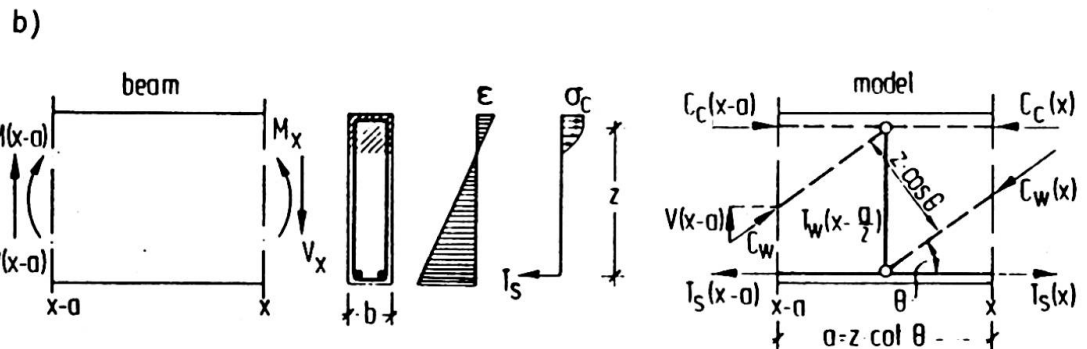
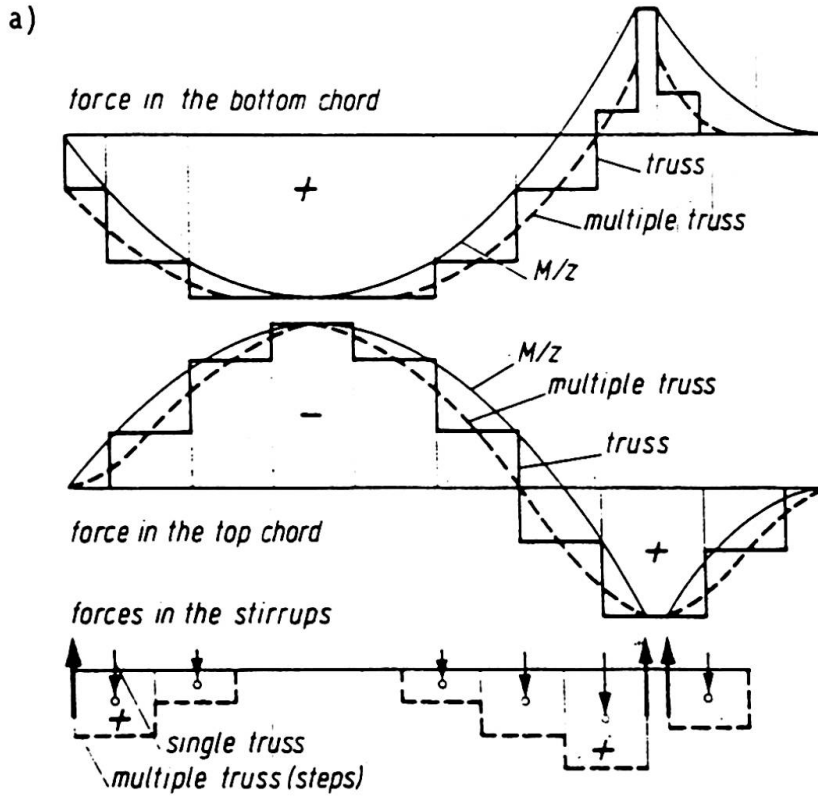
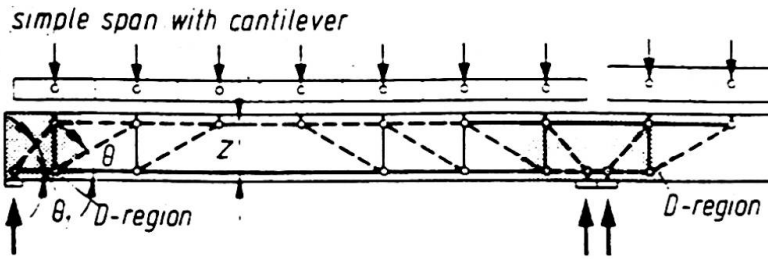

$$C_c(x) = \frac{M(x)}{z} - \frac{V(x)}{2} \cot \theta$$

$$C_w(x) = \frac{V(x)}{\sin \theta} \longrightarrow \sigma_w(x) = \frac{V(x)}{bz \sin \theta \cos \theta} \text{ (smeared diagonal stress)}$$

$$T_w(x - \frac{a}{2}) = V(x) \longrightarrow t_w(x - \frac{a}{2}) = \frac{V(x)}{z \cot \theta} \text{ (per unit length of beam)}$$

$$T_s(x) = \frac{M(x)}{z} + \frac{V(x)}{2} \cot \theta$$

$V(x)$ may include shear forces from torque M_T .

c)

Fig. 2: Truss models of a beam with cantilever: (a) model; (b) distribution of inner forces; (c) magnitude of inner forces derived from equilibrium of a beam element.

3. MODELS FOR STRUCTURES CONSISTING OF D-REGIONS ONLY E.G. DEEP BEAMS

In this case the analysis of sectional effects by a statical system makes no sense anymore and the inner forces or stresses can be determined directly from the applied loads following the principles outlined for D-regions above, already.

In /3,4/, where the modelling and dimensioning of D-regions with STM is described in all details, it is proposed to orientate the geometry of the STM at the elastic stress fields, which means to utilize the same model for the serviceability and the ultimate stress check (fig. 3). Of course this does not exclude adjusting the model geometry whilst approaching failure towards an increase of the internal lever arms (fig. 4).

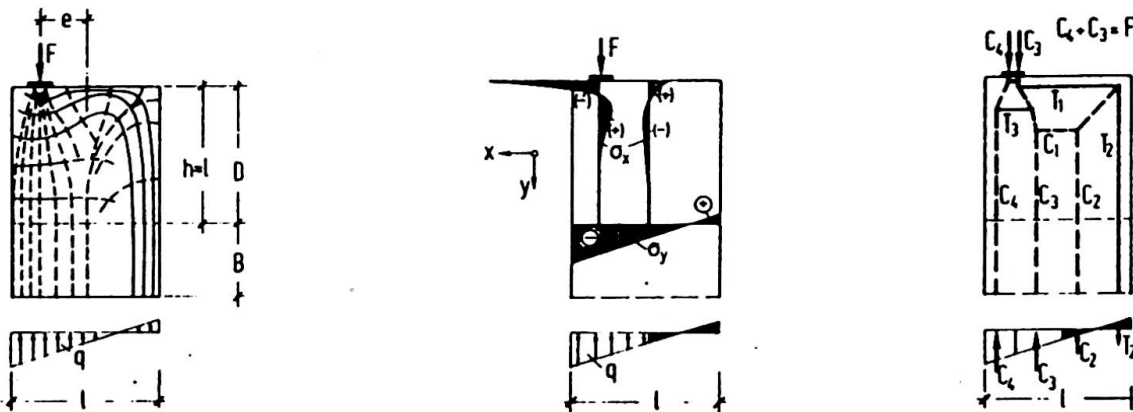

Fig. 3: A typical D-region: (a) elastic stress trajectories; (b) elastic stresses; (c) strut-and-tie-models.

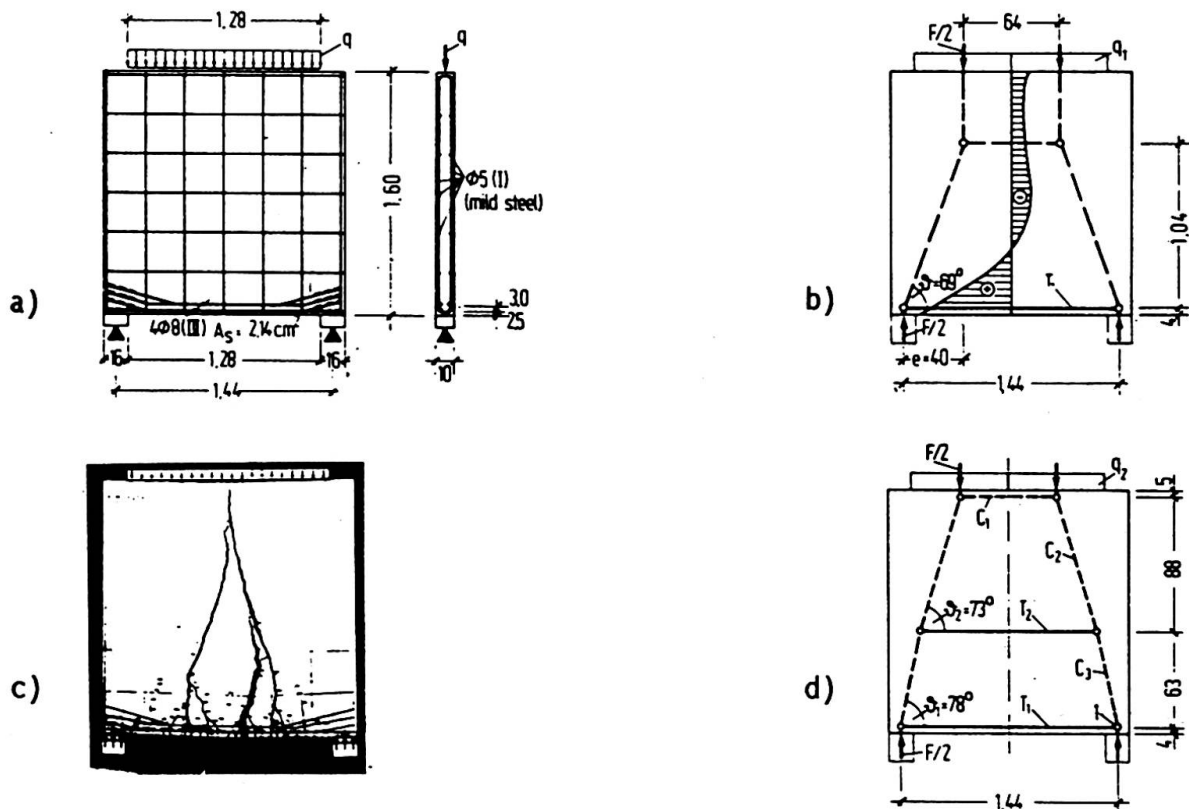

Fig. 4: Deep beam: (a) Tested specimen WT2 /7/; (b) model oriented at the theory of elasticity; (c) crack pattern from test; (d) model adjusted to the failure mechanism.



The designer will decide in the individual case, whether he finds his STM on his own, where the "load-path method" will be a valuable tool (fig. 5), or if he wants in a more complicated case to start with a linear elastic FEM analysis (fig. 6).

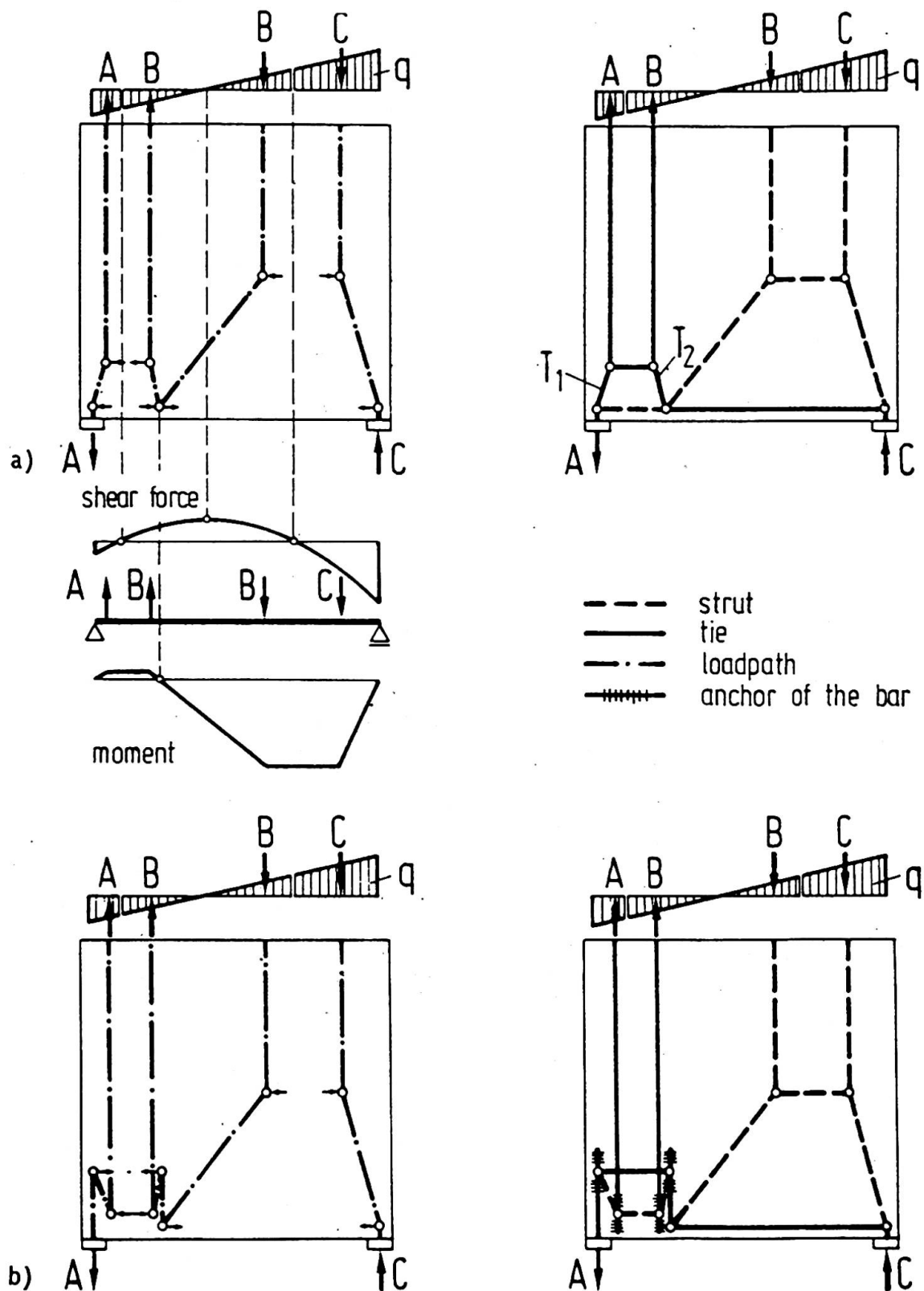

Fig. 5: Application of the load path method for finding the appropriate strut-and-tie-model. Two models for the same case: (a) requiring oblique reinforcement; (b) for orthogonal reinforcement.

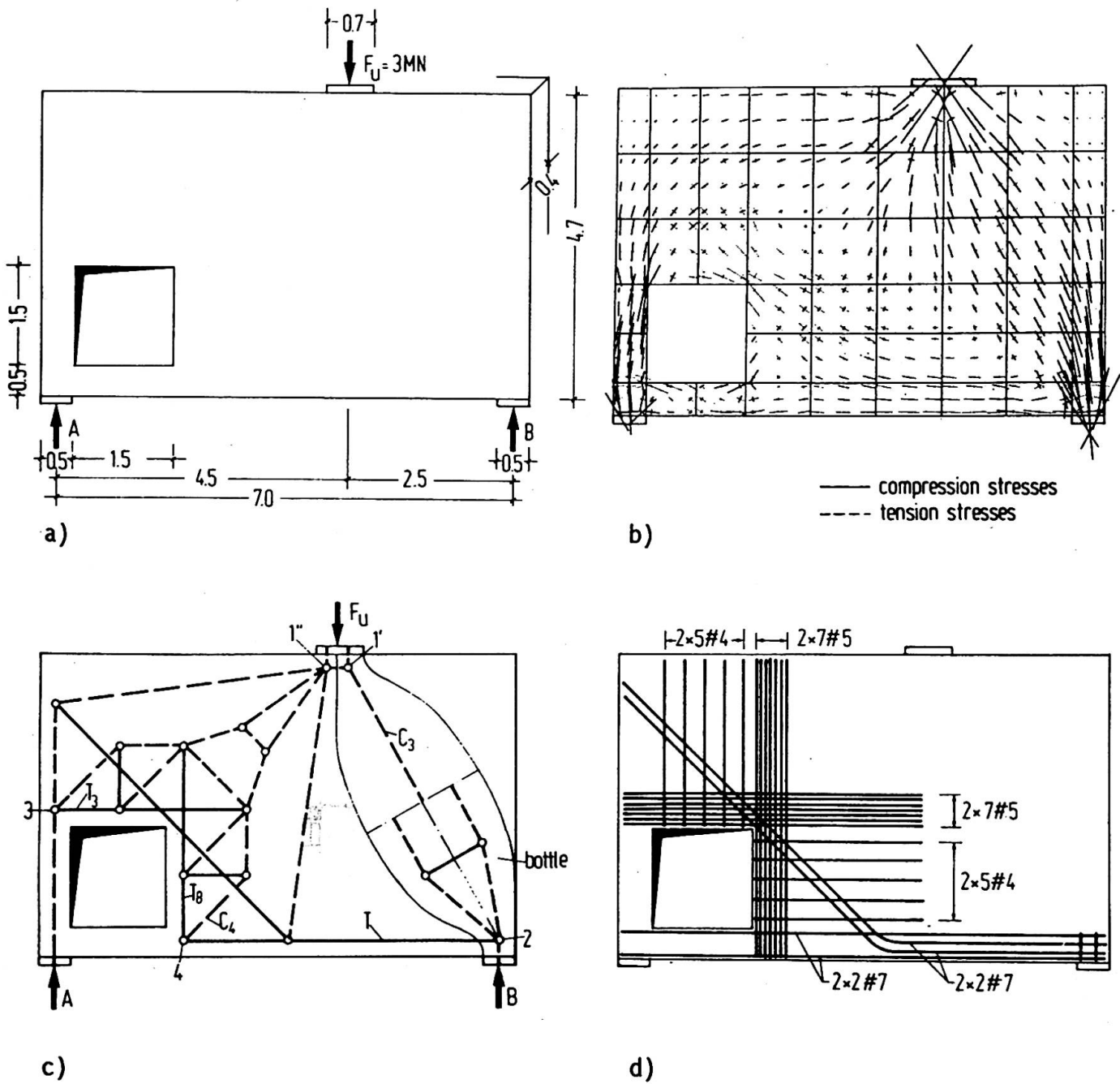

Fig. 6: Deep beam with a large hole: (a) dimensions /m/ and load; (b) elastic stresses; (c) complete strut-and-tie-model; (d) reinforcement.

Recently the fact that the STM-dimensioning is a combined graphical and analytical method has led to very useful CAD programs, which permit to develop, optimize and dimension STM on the screen /8,9/. This also opens the door to not only dimensioning D-regions but also to analyse them by attributing non-linear constitutive laws to the struts and ties thus being able to evaluate the deformations and the redundant inner forces for statically indeterminate supported deep beams. Comparisons of such analyses with test results on the one, and non-linear FEA on the other did yield promising results.

There has been some dispute on the so-called ambiguity of the STM, mainly from code-makers running after cookbook recipes. It's not the STM, it's reinforced concrete itself, which has fortunately the capability to adjust its inner flow of forces to the designer's reinforcement layout. A complex and intelligent material belongs into the hands of an experienced designer. He will find the right STM for his specific case and will keep serviceability and ductility requirements in mind, when optimizing it towards ultimate load capacity.



Fortunately there is a lot of progress with the non-linear FEA of cracked reinforced concrete. Thus the designer has the tool to review his STM results, from which he of course has to collect the reinforcement layout before doing a FEM check. Comparing both results will have a high pedagogical value and avoids misinterpretations of black-box computer outprints.

Such a procedure should be followed as a golden rule: Dimensioning on basis of relatively simple models, thereafter review on a suitable level of sophistication.

Non-linear FEA appears to be of special value, if the overall deformational behaviour of a deep beam or the reactions of a statically indeterminate supported deep beam structure is asked for. It will also be able to describe and clearly trace failures of concrete in compression or tension as well as of the reinforcement. For that of course it must be possible to model the real crack pattern, especially discrete cracks often responsible for failure. But doubts arise with respect to its capability of describing the behaviour of nodes. For that purpose it would be necessary to computerize the concrete at a microlevel i.e. to follow with the finite elements down to the gravel and reinforcement ribs.

From that it follows, that even a FEM analysis should be followed by a STM check especially with respect to the safety of the nodes (fig. 7).

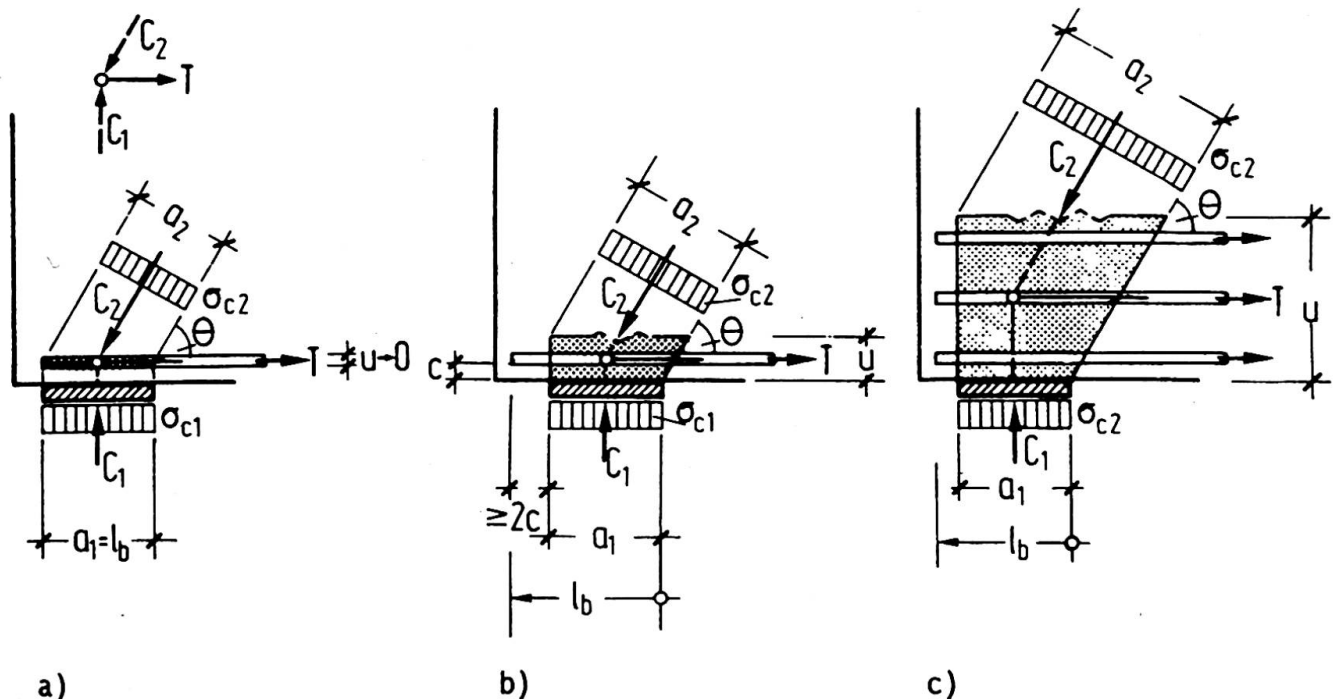

Fig. 7: Typical node for the anchorage of reinforcement: (a) one layer; (b) one layer with additional length behind the node; (c) three layers with additional length behind the node.

4. MODELS FOR SLABS AND FOLDED PLATES

Since these structures may as well be sub-divided into B- and D-regions, the same models and methods as discussed above may be applied as well. In fact they predominantly consist of B-regions (plane strain distribution). Starting from the sectional effects of the structural analysis, imaginary strips of the structure can be modelled like linear members.

However, it would be desirable to develop a real STM approach which considers that the principal moments and forces of slabs do not follow straight lines parallel to the edges.

Further there is no satisfactory model as yet describing punching of slabs. For the large variety of slab shapes with all kinds of openings it is very helpful, that today FEM programs on linear-elastic basis are available to any designer. Since slabs rarely do reveal substantial cracking, it may not be very desirable to repeat such an analysis with non-linear FEM. Rather will an overall ultimate capacity check by means of the yield line theory provide useful additional information.

5. TREATMENT OF PRESTRESS

In a paper on modelling of structural concrete, a word on the treatment of prestress may be expected. However, it appears sufficient to mention that consistency between reinforced and all "types" of prestressed concrete can easily be reached if for the analysis of the sectional forces prestress is simply treated, what it really is: a self-equilibrated outer load, though artificially applied. Whilst dimensioning, its forces are treated as are other forces. After grouting the prestressing steel will then assume the role of reinforcement (with an initial prestressing force and with special properties).

In case of prestress without bond or of external prestress after prestressing the tendons take the role of free ties whose changes of forces due to loads may be estimated or analysed on basis of a statical indeterminate system /3/.

With this the same models and methods as already discussed apply also to the case of prestress (fig. 8). This treatment helps to avoid useless discussions as those, whether the statical indeterminate moments due to prestress are restraint forces which disappear due to cracking or not. Of course they are not, they are moments as those due to any other outer loads which cannot disappear but of course be redistributed. This view of prestress is a valid basis for the consistent treatment of structural concrete and for a simplification of codes.

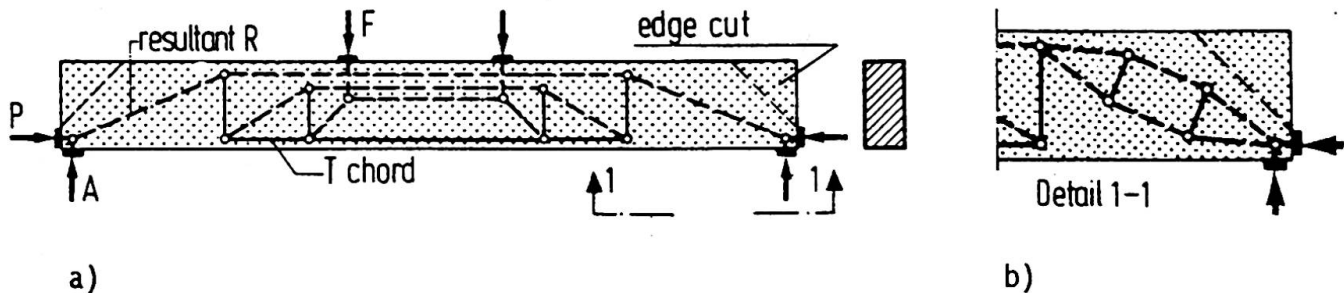

Fig. 8: (a) Strut-and-tie-model of partially prestressed beam with rectangular cross section;
 (b) detailed strut-and-tie-model of the beam area, where the resultant is within the beam section.

6. SUPPORT OF A CANTILEVERING BOX GIRDER ON TWO WALLS

AN EXAMPLE: The reader will understand the STM-method best by following an example described in all details here:

6.1 General Layout

How to carry the forces in the connection of the members shown in Fig. 9a? Normally diaphragm walls are introduced in the box girder, either two directly above the two supporting walls (Fig. 9b), or - because the inner one is difficult to construct - just one at the end of the box girder (Fig. 9c). The best solution, a diagonal wall, is not obvious in the beginning.

6.2 Frame Corner with Diaphragm Wall at the Box Girder's End only

The diagonal struts C_3 (Fig. 10a) which balance the chord forces T_1 (from the box girder's tensile flange) and T_2 (from the tensile wall) with the compressive forces C_1 and C_2 from the respective compression chords of the frame type structure can only be transferred within the two webs. Therefore, all the chord forces which in the adjacent B-regions are well distributed over the whole widths of the flanges have to be deviated and bundled into the small width of the webs.

First of all, this requires considerable transverse reinforcements in the four chord members according to the strut models given in Figs. 10b-e. The models are all of one type, which appears very frequently in D-regions of very different structures. The internal lever arm z of the transverse forces in Figs. 10c and 10e, oriented at theory of elasticity is approximately $0,6 b$. In Figs. 10b and d the corresponding lever arm depends also on the length of overlap of longitudinal reinforcement. Standard lap lengths in Codes do not apply for this situation where the lapped bars are arranged at some distance from each other. A more detailed model (Fig. 10f) of this typical problem shows different transverse tie forces in different places.

Looking again at the struts C_1 and C_2 in plan and sections of Fig. 10 we realize that the corresponding stress fields must be squeezed through the bottleneck of the singular node 2 whose dimensions are restraint

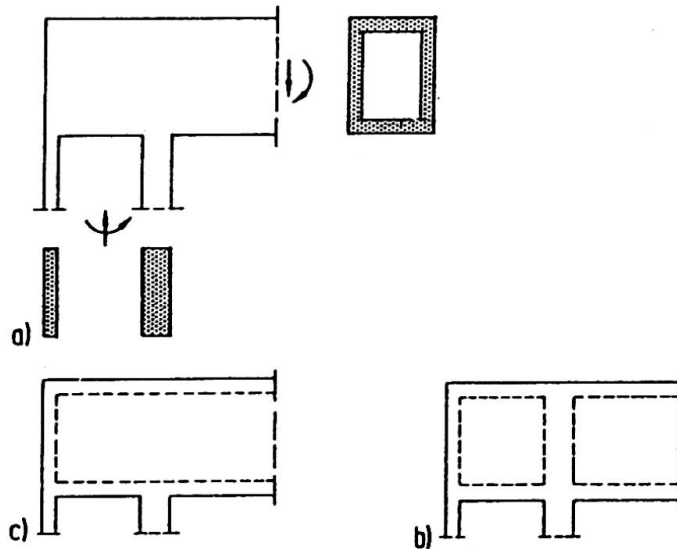

Fig. 9: a) View and cross-section of the box girder and support walls. b) Longitudinal section with interior diaphragm wall. c) Longitudinal section without interior diaphragm wall

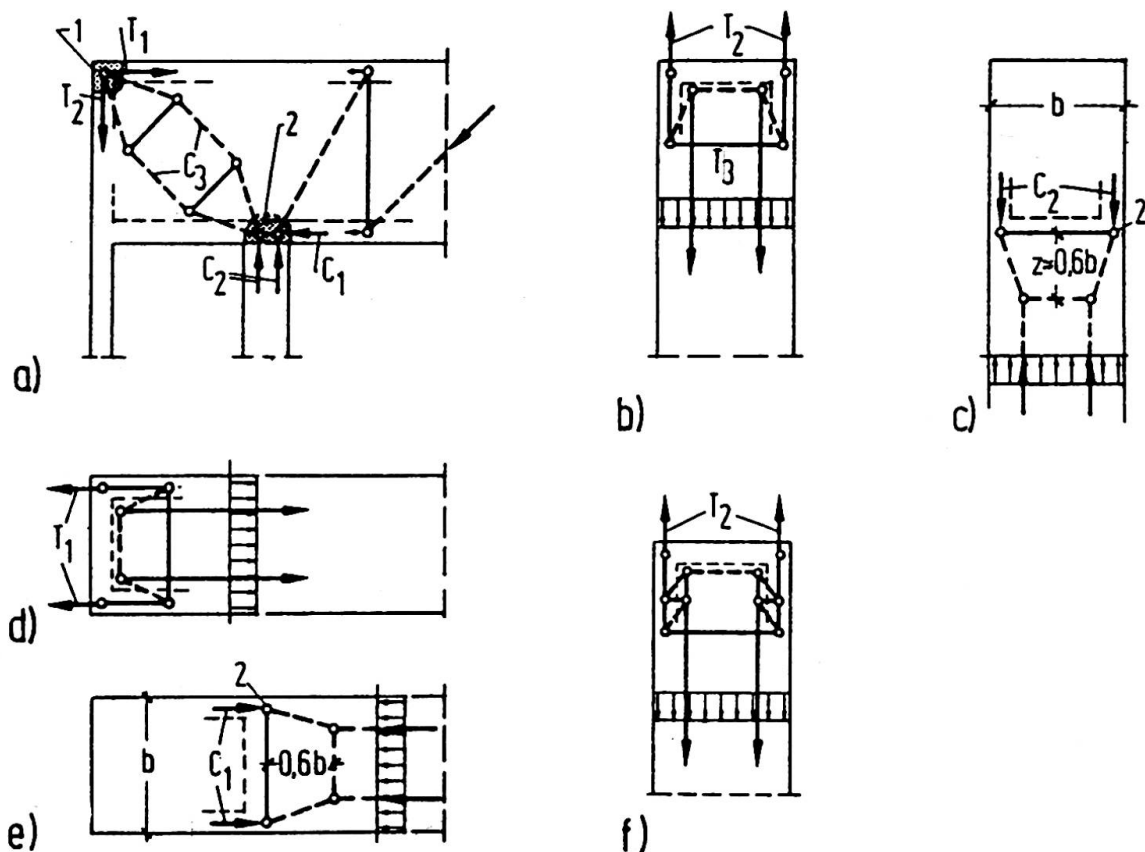

Fig. 10: Strut-and-tie models for the structure without internal diaphragm wall. a) Web; b) tensile wall; c) compression wall; d) top flange; e) bottom flange. f) Refined model for the lap problem characterized in Figs. b and d

by the thicknesses of the compression wall, web and bottom slab of the box girder. This node will dictate the concrete dimensions, the large width b of the box girder slab cannot be used as compression zone. What an unreasonable structure! Who would have recognized this, applying the usual design rules?

A similar problem may arise in node 1, where tensile bars for the total chord forces T_1 resp. T_2 must be arranged within the thickness of the web or at least very close to it in order to avoid large "slab moments" in

the deck and wall. Also this node will become a singular node if reinforcing bars were bent sharply around the corner as shown in Fig. 10a. Consequently, the diagonal strut force C_3 in the web will spread out between nodes 1 and 2, thereby creating transverse tensile forces as indicated in Fig. 10a. Therefore it is much better to bend the chord reinforcement using a mandrel which is adapted to the dimensions of the frame corner (Fig. 3).

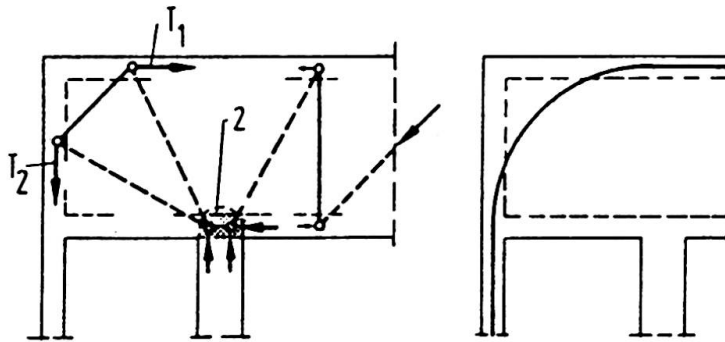

Fig. 11: Model and corresponding chord reinforcement with a well adapted mandrel diameter

By the way, omitting the lower diaphragm plate between the two walls would do no additional harm to the (poor) structural solution. Either none or two orthogonal diaphragms are needed, as will be shown hereafter.

6.3 Frame Corner with Two Diaphragm Walls

The necessary transverse reinforcement in the boxgirder plates and the supporting walls is the same as before; but the singular nodes are avoided since the chord forces T_1 , T_2 , C_1 , C_2 now enter the web reasonably well distributed over the whole length of the diaphragms (Fig. 12a). In other words: Each chord plate is no longer supported on two points only but rather along two lines (Fig. 12b). As a consequence the load bearing capacity of the frame corner is essentially increased by the additional diaphragm wall.

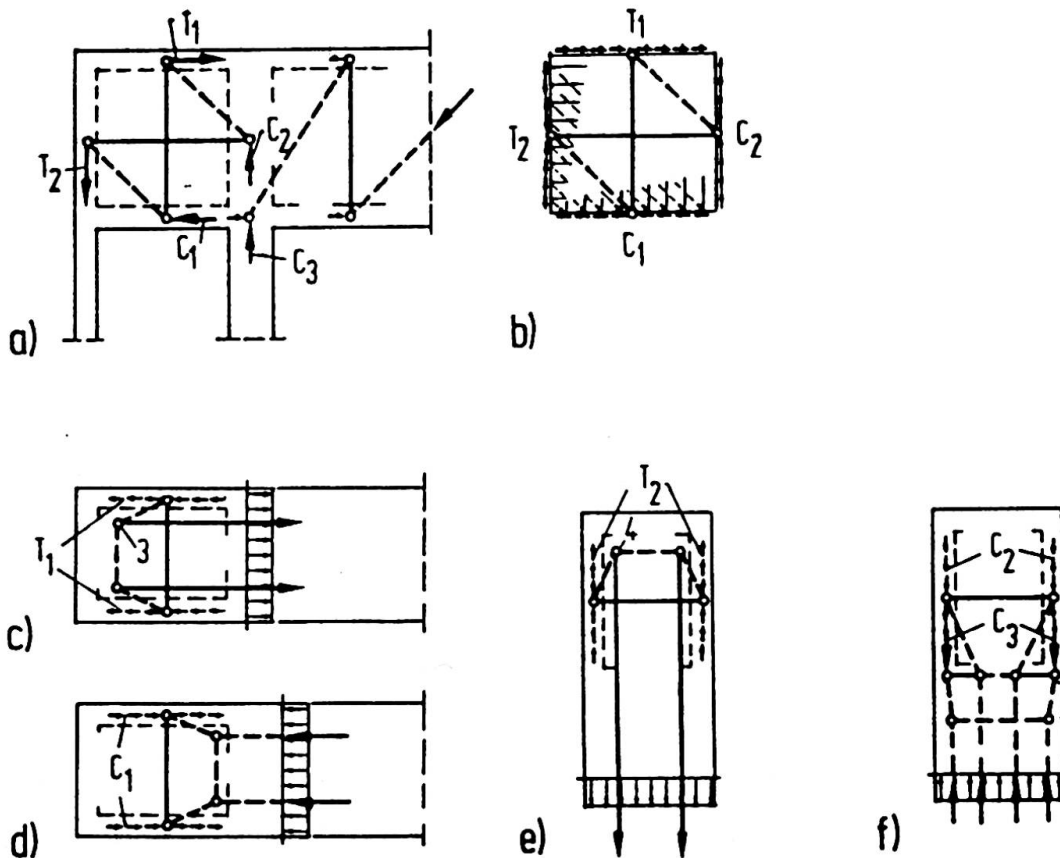

Fig. 12: Strut-and-tie models for the structure with internal diaphragm wall. a) Basic model for the web. b) refined model for the web with smeared forces. c) Top flange. d) Bottom flange. e) Tensile wall. f) Compression wall



6.4 Frame Corner with Diagonal Diaphragms

The best structural solution for the discussed problem is the diagonal diaphragm which follows the load path T_2 in Fig. 13a. This model avoids not only the singular nodes but also the transverse reinforcements in the flanges and walls. Only the spreading out of the support forces C_3 , resulting from the shear forces of the webs, require some transverse reinforcement T_3 near the top of the compression wall (Fig. 13b).

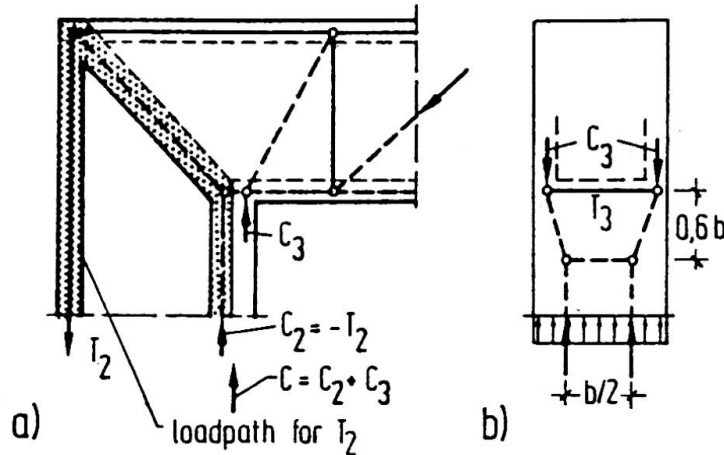

Fig. 13:a) Diagonal diaphragm following the load path for T_2 of the strut-and-tie model. b) Model for the compression wall.

We can conclude from this example that strut-and-tie models are not only suitable for dimensioning but are also very helpful for the conceptual design of good structural solutions.

6.5 The same Structure with Prestress

Let's prestress now the top plate and tension wall of the structure without inner diaphragm wall (see Fig. 9c) with prestressing forces $P_1 = T_1$, $P_2 = T_2$ just large enough to balance the concrete tensile forces T_1 , T_2 due to dead load (Fig. 14a). At first sight one could think that thereby also the problem of transverse forces in the frame corner is cancelled, at least in the prestressed members. But it isn't at all! The model with prestress applied as external forces (see section 5 and [2,3]) discloses that the load paths of the compression forces C_1 , C_2 have to squeeze as before (see section 6.2) through node 2 into webs in order to arrive at their "supports" provided by the anchor forces P_1 , P_2 of the tendons. In order to avoid further detours of the load paths (see Fig. 10b and d), the tendons in the corner should be arranged within the web, either similar to Fig. 11 or Fig. 14b, thus balancing the compression strut in the web directly.

If the load is increased after prestressing, e.g. due to live loads or a safety factor for ultimate conditions, the tendons react like non-prestressed reinforcement with additional tendon forces ΔT_1 , ΔT_2 . These are anchored by bond according to the model shown in Fig. 14c.

In the structure with inner diaphragm wall (acc. to Fig. 12) the tendons may be distributed over the whole width b of the structure and anchored near the edge, if transverse forces are carried according to the models given in Fig. 12c and e. However, the position of the model nodes 3, 4, which in Fig. 12c and e represent the centroid of bond forces, have to be reconsidered for the prestressing tendons (see Fig. 14c). The prestress force P is always applied at the tendon anchor. Only that part of the tendon force ΔT which exceeds the initial prestress force P is anchored by bond, and these bond stresses may develop at a considerable distance from the anchor.

Separating the prestressing loads from the additional tendon forces after prestressing as suggested by Breen, Bruggeling and Jennewein [1,10,11] is reasonable also for the application of strut-and-tie models to prestressed D-regions and leads to a clear understanding of structural behaviour.

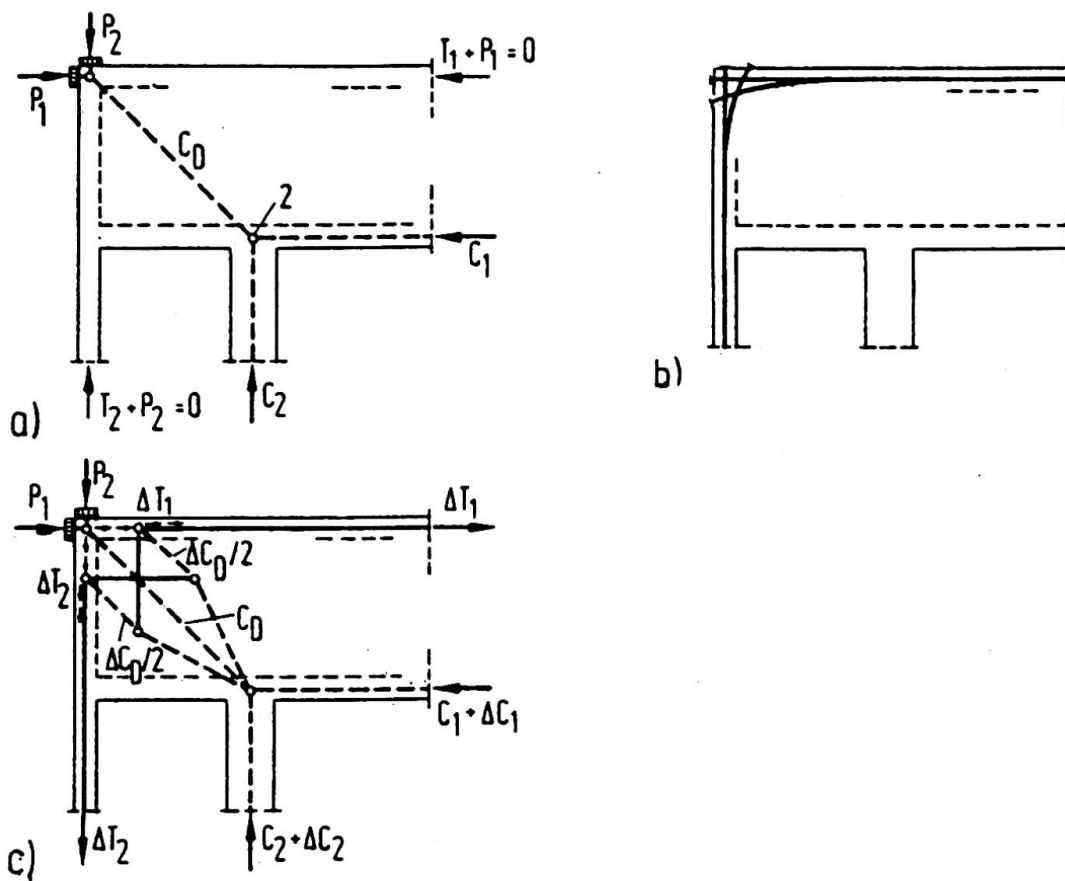

Fig. 14: Prestressed structure without internal diaphragm wall a) Top slab and tension wall prestressed under dead load to give zero concrete stresses. Model showing the load paths. b) Practical reinforcement layout c) Strut-and-tie model for increased loads, prestress as before.

**REFERENCES**

1. BREEN J., Why structural concrete? Introductory report. IABSE Coll. "Structural Concrete" Stuttgart 1991
2. SCHLAICH J., WEISCHEDE D., Ein praktisches Verfahren zum methodischen Bemessen und Konstruieren im Stahlbetonbau. Bulletin d'Information No. 150. CEB, Paris, March 1982
3. SCHLAICH J., SCHÄFER K., JENNEWEIN M., Toward a consistent design of structural concrete. PCI Journal vol. 32 no. 3 May/June 1987
4. SCHLAICH J., SCHÄFER K., Konstruieren im Stahlbetonbau. Betonkalender 1989. Ernst und Sohn
5. REINECK K.-H., Ultimate Shear Force of Structural Concrete Members without Transverse Reinforcement Derived from a Mechanical Model. ACI Structural Journal, no. 88-S61, Sept./Oct. 1991, pp. 592-602
6. MARTI P., Truss models in Detailing. Concrete International, V.7, No. 12, Dec. 1985, pp. 66-73
7. LEONHARDT F., WALTHER R., Wandartige Träger. DAFStb-Heft 178
8. ANDERHEGGEN E., SCHLAICH M., Computer-Aided Design of Reinforced Concrete Structures using the Truss Model Approach. Proceedings for Second International Conference on Computer-Aided Analysis, Vol. 1, pp. 539-550, Zell am See/Austria, April 1990
9. RÜCKERT K., Design and analysis with strut-and-tie models. - Computer aided methods. IABSE Colloquium "Structural Concrete" Stuttgart 1991
10. BRUGGELING A.S.G., An engineering model of structural-concrete. Introductory report IABSE Colloquium "Structural Concrete" Stuttgart 1991
11. JENNEWEIN M., Some remarks on the analytical treatment of prestressing. IABSE Colloquium "Structural Concrete" Stuttgart 1991
12. SCHLAICH J., Modelling. Invited lecture. IABSE Colloquium "Structural Concrete" Stuttgart 1991