

XI. Developments in the construction of reinforced and prestressed concrete structures

Objekttyp: **Group**

Zeitschrift: **IABSE congress report = Rapport du congrès AIPC = IVBH
Kongressbericht**

Band (Jahr): **12 (1984)**

PDF erstellt am: **25.09.2024**

Nutzungsbedingungen

Die ETH-Bibliothek ist Anbieterin der digitalisierten Zeitschriften. Sie besitzt keine Urheberrechte an den Inhalten der Zeitschriften. Die Rechte liegen in der Regel bei den Herausgebern.

Die auf der Plattform e-periodica veröffentlichten Dokumente stehen für nicht-kommerzielle Zwecke in Lehre und Forschung sowie für die private Nutzung frei zur Verfügung. Einzelne Dateien oder Ausdrucke aus diesem Angebot können zusammen mit diesen Nutzungsbedingungen und den korrekten Herkunftsbezeichnungen weitergegeben werden.

Das Veröffentlichen von Bildern in Print- und Online-Publikationen ist nur mit vorheriger Genehmigung der Rechteinhaber erlaubt. Die systematische Speicherung von Teilen des elektronischen Angebots auf anderen Servern bedarf ebenfalls des schriftlichen Einverständnisses der Rechteinhaber.

Haftungsausschluss

Alle Angaben erfolgen ohne Gewähr für Vollständigkeit oder Richtigkeit. Es wird keine Haftung übernommen für Schäden durch die Verwendung von Informationen aus diesem Online-Angebot oder durch das Fehlen von Informationen. Dies gilt auch für Inhalte Dritter, die über dieses Angebot zugänglich sind.



SEMINAR

XI

Developments in the Construction of Reinforced and Prestressed Concrete Structures

Développements dans l'exécution de constructions en béton armé et précontraint

Entwicklungen bei der Ausführung von Stahlbeton- und Spannbetonbauwerken

Chairman: A.G. Frandsen, Denmark

Coordinator: R. Favre, Switzerland

General Reporter: P. Richard, France

Leere Seite
Blank page
Page vide

Prestressed Concrete Highway Bridges in China

Ponts-route en béton précontraint, en Chine

Strassenbrücken aus Spannbeton in China

Lichu FAN
Assoc. Prof.
Tongji University
Shanghai, China



Lichu Fan, born 1933, graduated from the Tongji University in 1955. At present, he is the chief of the Civil Engineering Division of the Structural Engineering Department.

SUMMARY

This paper briefly describes the progress and trends of prestressed concrete bridges in China. Some typical examples of prestressed concrete bridges in China are presented to show application and development of long-span highway bridges, as well as their design concepts and structural analysis.

RESUME

Ce rapport présente succinctement les progrès et les tendances des ponts en béton précontraint en Chine avec quelques exemples typiques montrant l'application et le développement dans les ponts de grande portée, ainsi que leur conception et leur calcul.

ZUSAMMENFASSUNG

Der Beitrag behandelt hauptsächlich die Fortschritte und Tendenzen im Spannbetonbrückenbau in China. Einige typische Beispiele von Spannbetonbrücken in China werden präsentiert, um die Anwendung und Entwicklung der weitgespannten Spannbeton-Strassenbrücken zu zeigen. Entwurfskonzepte und Tragwerksanalyse von Spannbetonbrücken werden dazu skizziert.



1. INTRODUCTION

As early as the 1950's. Chinese bridge engineers had already begun on research work of the application of P.C. bridge. The first P.C. bridge consisted of simply-supported girders with 20 m span built in 1956.

During the period of the 70's and 80's, the design and construction of P.C. bridge developed with great speed in application of different structural systems and their maximum span lengths, as shown in Fig.1. Up to now, 11 cable-stayed bridges, 18 balanced cantilever bridges (e.g. T-frame), 19 continuous girder

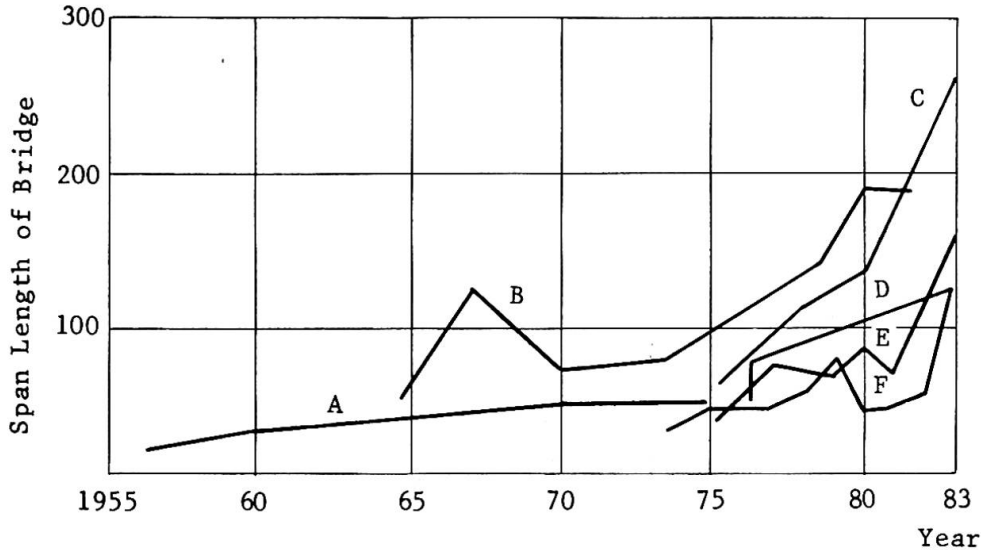

- A: Simply Supported Bridges
- B: Balanced Cantilever Bridges
- C: Cable-stayed Bridges
- D: Balanced Cantilever Truss Bridges
- E: Truss Arch Bridges
- F: Continuous Bridges

Fig.1 Maximum Span Length Records of P.C. Bridge in China

bridge, 5 truss arch bridges and 4 balanced cantilever truss bridges have been built by adopting the new construction technique, such as: 1) balanced cantilever casting, 2) incremental launching, 3) segmental construction and 4) erection by the 4905 KN floating crane. In 1983 a number of long-span P.C. bridges ($L > 50m$) were under construction or planning, as shown in Fig.2 and Table 1, from which it may be seen that the development of long-span P.C. bridge in China is quite outstanding.

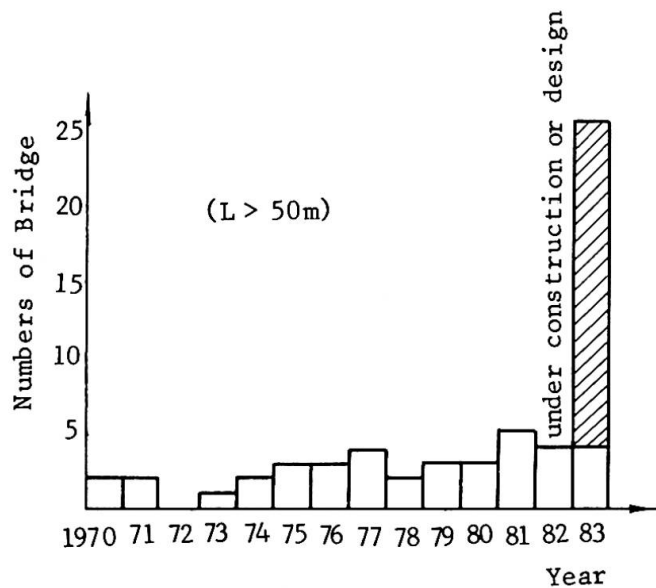

Fig.2 Numbers of P.C. Bridge in China

Table 1 Some Major P.C. Bridge under Design and Construction in China

Name of bridge	Location	Main Span length (m)	Structure System
Yonghe	Tianjin	260	cable-stayed bridge
Changde	Hunan Province	120	continuous bridge
Hongtong	Fujian Province	120	balanced cantilever truss bridge with lower deck
Jianhe	Guizhou Province	150	cantilever truss arch

2. TYPICAL EXAMPLES OF LONG-SPAN P.C. BRIDGE

2.1 Balanced Cantilever P.C. Bridge (or T-frame Bridge)

The Chongqing Changjiang Bridge in Sichuan Province, completed in 1980, composed of eight spans of 81.5m - 4 × 138m - 156m - 174m - 104.5m (Fig.3). Up to now, it is the longest of the T-frame bridge with a total length of 1073m and

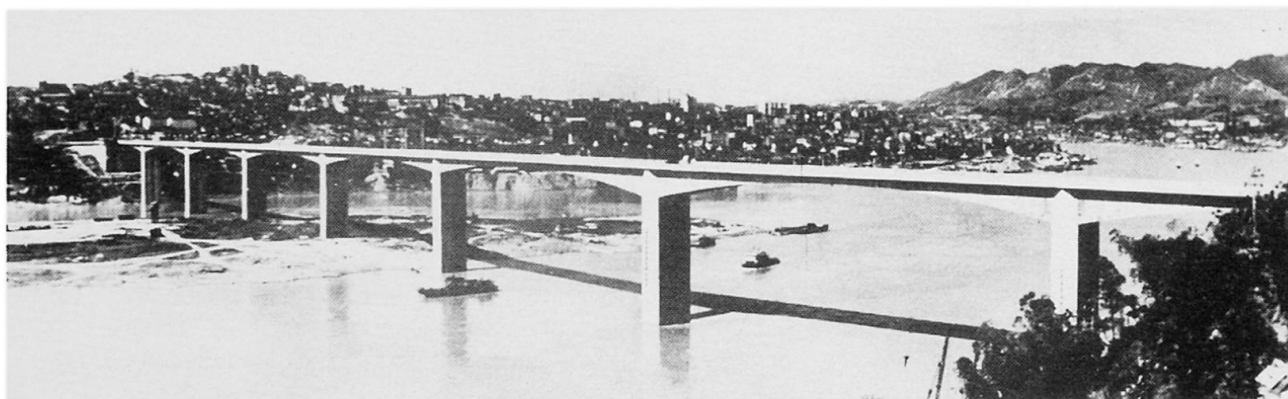

Fig.3 Chongqing Bridge

a total width of 21m, comprising a four-lane roadway of 15m and two sidewalk of 3m each. The bridge superstructure was designed as cast-in-site, post-tensioned P.C. box girder, symmetrically cantilevered from the piers by the segmental cantilevered construction method. A 35m precast suspended span is located in the middle in order to connect the adjacent cantilevers. The cross-section of the cantilevers is made up of two separate single-cell boxes. The length of the cantilevers range from 51.5m to 69.5m with cross-section heights between 11m at the piers to 3.2m at the cantilever ends.

On the bridge site, the bedrocks outcropped at both sides of the river bank, and the overlying soil layers below the river bed vary from 3-4m to 21.4m. According to geological condition at the location of each piers, three forms of foundation are adopted. The side span piers are founded on spread footings or R.C. caissons, and the main span piers are founded on 12 bored piles of 260m diameter, constructed in steel plate cofferdams. These piers are designed as hollow R.C. rectangular columns with two intermediate wall and constructed by slip forms. The main span piers with a maximum height of 64m is designed to resist a ship collision force of 4905 KN at right angle to the bridge center line and 2943 KN in the direction of the bridge.



2.2 P.C. Cable-stayed Bridge

2.2.1 The Maogong Bridge crossing Mao River in Shanghai suburb was opened to traffic in 1982. The main span is 200m and two side spans are 85m each, totaling 370m (Fig.4). Throughout the bridge site, the substrata are very soft



Fig.4 Maogong Bridge

clay. Unequal settlements of piers and abutments may amount to 30m, the bridge superstructure was designed as an externally static determinate structure system. It has two cantilever box girders of constant depth 2.2m rigidly fixed to 44m high portal frame pylons and a 30m suspended span which is provided in the middle of main span which is provided in the middle of main span to connect two cantilevered portions. The cables are arranged in two plans each of which consists of 11 pairs of inclined cables in parallel form. For the main span the segmental cantilevered construction method was adopted. The side spans were constructed on

a temporary scaffold. The cantilever box girders are supported on neoprene bearings in the main span, with a movable and adjustable steel pendulum link supports which, in side span for anchor spans, can rotate 5% longitudinally to maintain the superstructure statically determinate under D.L. during the course of settlements of piers and abutments after the girder deflected to a certain value. Under the service condition, the pendulum link bearing will subject to tension or compression with the L.L. in the center span or side span. Total width of the bridge deck is 9m, comprising two-lane roadway and two sidewalks.

The cables composed of two tendons of 73 ϕ 5mm wires are used on the bankside and two tendons of 147 ϕ 5mm wires on the river side.

2.2.2 The Ji-Nan Huanghe River Bridge, completed in 1982, shown in Fig.5, is located in the northern suburb of Ji-Nan City, the capital of Shandong Province.

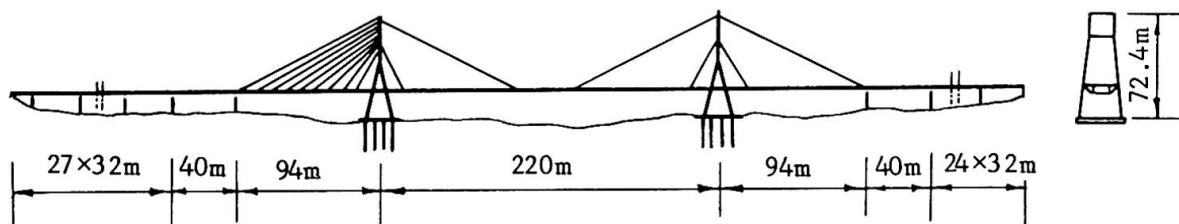

Fig.5 Ji-Nan Huanghe Bridge

The bridge is the current record for P.C. cable-stayed bridge in China, with a main span of 220m, total length of 2,022.8m and total width 19.5m, comprising four-lane roadway. The approach spans consists of 51 @ 30m prestressed composite structure. This P.C. cable-stayed bridge has 5 spans (40m - 94m - 220m - 94m - 40m) continuous box girders suspended at the "A" shape towers with close spaced cables.

The main girder is designed as two separated closed box girders with sharp edged wind nose, and with a centre slab deck and intermediate diaphragms, in accordance with the requirements of aerodynamic stability and static wind forces.

The bridge is constructed by cast-in-situ segmental cantilever construction method.

The two main R.C. towers, standing about 60m above the water, are rigidly fixed on piers supported by 24 casted piles of 1.5m diameter bored to a depth of 84m below bed-level and embedded into weathered rocks. Cables are made up of 4-8 tendons, in turn, composed of 67-121 parallel wire of 5mm diameter made of galvanized high strength steel. The coldcast button headed anchorages are being used.

The whole superstructure is designed as a floating system, no bearings are used in the main span, only sliding bearings are provided at extreme pier and auxiliary pier. The expansion joints are located at each end of the 488m main bridge. The bridge is designed for an earthquake intensity of VII.

2.2.3 The Yonghe Bridge in Tianjin will be the longest of the P.C. cable-stayed bridge with main span 260m, and now is under construction. The bridge is also designed as a floating system to withstand the strong earthquake response in the longitudinal direction. It has 5 spans of 25.15m - 99.85m - 260m - 99.85m - 25.15m with the total length of 510m and the width of 11m (Fig.6).

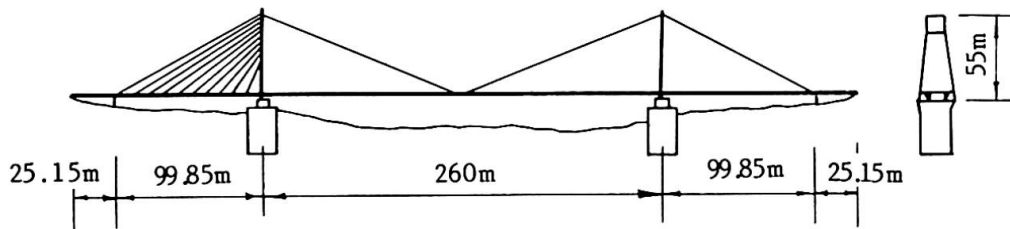

Fig.6 Yonghe Bridge

2.3 P.C. Continuous Bridge

2.3.1 The Shayang Bridge forms a link across the Hanjiang on the highway from Hankou to the Yichang in Hubei Province, which is now under construction (Fig.7).

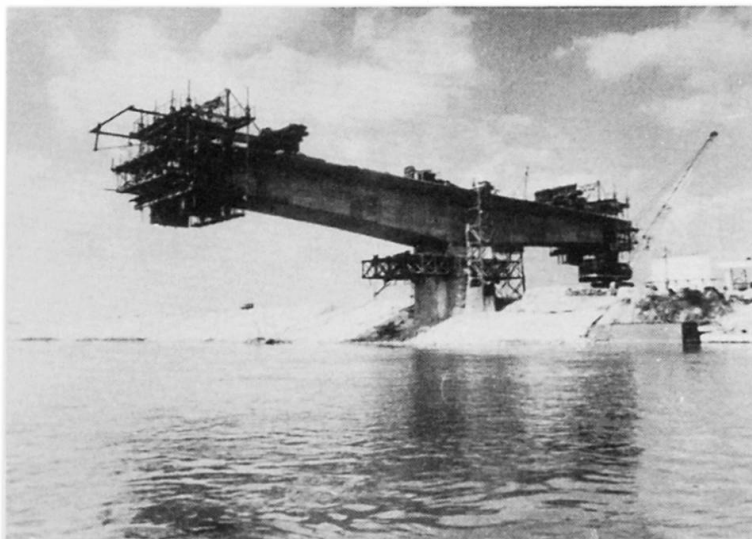

Fig.7 Shayang Bridge

The bridge includes a P.C. continuous box girder with eight spans of 63m - 6 × 111m - 63m, and 33 spans of 30m for approaches, totalling 1815.5m. The bridge superstructure is a cast-in-situ post-tensioned concrete box girder with a cantilever system for D.D. and with continuity for L.L. by a casting joint section at mid-span to connect the adjacent cantilever. The cross-section is designed as a central box girder with cantilever bridge deck. The width of the box is 6m and the depth varies between 6m at the piers and 3.0m at mid-span. The total bridge deck width is 12.5m.

The bridge is constructed by balanced cantilevered method. During the construction, the cantilevered box girder is temporary fixed on pier by vertical prestressed tendons to maintain equilibrium.



The approach piers are each founded on two bored R.C. piles of 180cm diameter, and the piers of main spans are founded on R.C. caissons on sand-gravel rock.

2.3.2 The Rongqi Bridge is located in Guangdong Province and is also under construction. The main span is 90m, approach span 30m and total length 1017.06m. The superstructure of the main bridge (spans 73.6m - 3 × 90m - 73.6m) is designed as a precast segmental, post-tensioned continuous box girder, the cross section of which is two separate boxes flanked by centrogated cast-in-situ joint section in 1.8m distance. The box girder divided 9 large precast units along bridge center line whose size depends upon self-weight not more than 4905 KN (Fig.8).

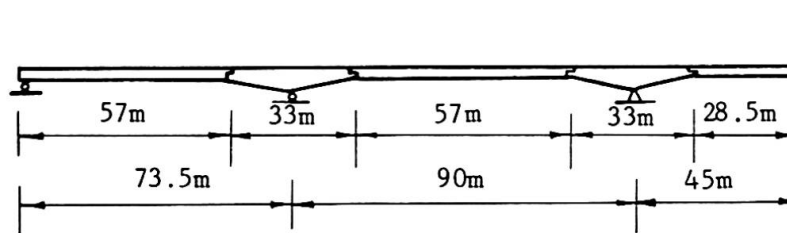

Fig.8 Side View of the Rongqi Bridge

2.4 Balanced Cantilever Truss Bridge with Lower Deck

The Gangkou Bridge with a main span 70m in Zhejiang Province is now under construction, and the Hongtang Bridge with a main span 120m in Fujian Province is in design stage. Both are the balanced cantilever truss bridge with lower deck which is adopted in order to make possibility to reduce the construction height of bridge and to maintain the maximum navigational clearance.

The overall length of the Tongtang Bridge is approximately 1625m separated in 360m main bridge (Fig.9) and 1265m approach spans. The construction height

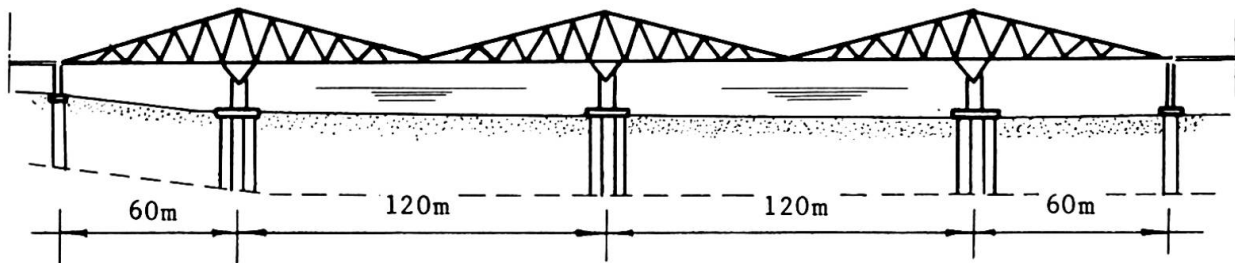

Fig.9 Hongtang Bridge

of the bridge is only 1.32m, so that the span to depth ratio (L/h) is about 91. The navigational clearance in the main span is 10m in height.

The main bridge has two P.C. truss in 10.14m apart cantilevered over the piers and with a hinge in centre of each span. The behaviors of this bridge structure is the same as balanced cantilever box girder. The heights of the truss are 16m at pier and 1.32m at cantilever end. It should be pointed out that the bridge self-weight is reduced due to the truss instead of the box girder. The bridge deck is placed on the same level with lower chord in order to decrease the construction height of bridge.

The river piers with "Y" shape are founded on 14 bored piles, 150cm diameter, and the land piers are founded on 2 bored piles, 180cm diameter.

3. DESIGN AND STRUCTURE ANALYSIS

The specifications and standards for Chinese highway bridge has been promulgated since 1956, and the specification for P.C. bridge has been enforced since 1978 in China. They are being revised now with the principles of limit state design and advanced technology.

In Chinese prestressed concrete bridges partial prestressing is not allowed at present.

The standardized designs have been widely used, for instance, 1) the simply-supported P.C. girder bridge with span length under 40m, 2) the balanced cantilever P.C. box girder with span length 60m to 80m. It may suit the requirements of most small and medium bridges to be constructed on new highway lines.

In recent decade, a series of computer programs for both static and dynamic analysis of bridge structure by means of finite element method have been made and widely used in highway bridge designs. The function of those programs is quite complete for P.C. bridge, comprising the structure analysis at any construction stage, the redistribution of internal forces due to creep and shrinkage of concrete, the secondary moments caused by self-weight and prestressing, the temperature effects, the settlement of foundation, the earthquake response analysis of bridge structure and so on.

Aerodynamic stability and static wind force checked by extensive wind tunnel testing without the influence of traffic loads have been adopted for design of long-span cable-stayed P.C. bridge.

The Kalman's filtering method proposed by Chinese engineers is first used in cable-stayed bridge construction to control the erection deflection and cable forces with design values.

All of these mentioned above mark the new level in design and structure analysis of P.C. bridge in China

4. Conclusion

Up to now, more than 75% of major and medium bridges on the trunk highway in China are of prestressed concrete. It will be expected from this that we have accumulated quite valuable experience in the design and construction of P.C. bridges. We believe that in the near future, the development of design and construction of long-span P.C. bridge in China will rise to a new level.

Leere Seite
Blank page
Page vide

Two-Level Highway Bridge in Maribor

Pont autoroutier à deux niveaux à Maribor

Zwei-Etagen Brücke in Maribor

Vukašin AČANSKI
Prof. of Civil Eng.
Gip Gradis
Maribor, Yugoslavia



Mr. Ačanski was born in 1941 and awarded the Degree of Civil Engineering at University of Ljubljana. For 20 years he has been engaged in design of bridges and engineering structures. He is an adviser in the Design office of the firm, Gradis, and professor for prestressed concrete and bridge constructions at University in Maribor.

Peter KOREN
Civil Engineer
Gradis
Maribor, Yugoslavia

SUMMARY

A two-level bridge was built across the river Drava in Maribor. In the construction of the bridge, the technology of connecting the prefabricated line segments was used by grouting the elements with synthetic bonding agents (grouts) and by concreting the joints between the elements. The bridge was longitudinally prestressed and the carriageway slab was prestressed as well to obtain the continuity in the longitudinal and transverse direction.

RESUME

Un pont à deux niveaux a été construit à travers la rivière Drava à Maribor. Lors de la construction de ce pont, la technique employée pour réunir les segments linéaires préfabriqués a été effectuée par assemblage avec des colles synthétiques (mortier) et par bétonnage des joints entre les éléments. Le pont a été longitudinalement précontraint ainsi que la dalle pour obtenir la continuité longitudinale et transversale.

ZUSAMMENFASSUNG

In Maribor wurde eine 2-Etagen-Brücke über den Fluss Drava ausgebaut. Bei der Ausführung wurde die Technologie der Verbindung von Linienfertigteilen mit den synthetischen Klebemitteln (Mörtel) verwendet. Die Fugen zwischen den Elementen wurden in Ortsbeton ausgeführt. Das Objekt wurde in Längsrichtung vorgespannt, die Fahrbahnplatte in Querrichtung. So wurde die Kontinuität in Längs- und Querrichtung erzielt.



Maribor is a typical two-banks town. All the major traffic lines cross the river Drava, as well as one of the most important traffic streams in Europe, E 93, extending from the Phyrn - highway in Austria towards Balkan and the Near East. At the location of the European highway crossing the Drava there is also the center-point of the developing town and its traffic lines. Thus the solution to span the river for both, the transit and town traffic by means of one object, was evident by itself - that is to construct a two-level bridge. Such a solution allows the concentration of the otherwise unpleasant and expensive construction in the town area at one location, satisfying at the same time the requirements of both traffic types with only one site organization.

Maribor is a town of bridges and the new bridge has to be as well as possible incorporated into the town panorama, to serve by its function and aesthetic image the today and future generations (Fig. 1)

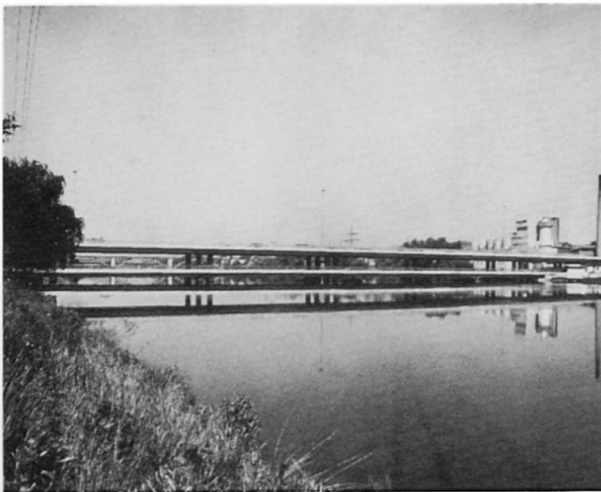

Fig. 1 : Bridge panorama



Fig. 2: The slab of the upper bridge

The grade line of the upper bridge carrying the highway is 8,0 m above the water level, and the grade line of the lower bridge serving for the local traffic is 2,0m above the water level.

The bridge is founded on bored piles. The spanning structure of both bridge levels is made of line segments - prefabricated concrete box girders connected into a ribbed slab (Fig. 2).

Such a system is frequently being used in the bridge construction. The environmental aspects of our country with a very diverse configuration, consisting of several wide and narrow valleys and rivers, as well as the need of constructing the two-level crossing for the highway and town road-network required to select a system that would satisfy all the above stated specificities. That system should be flexible enough to cover all the wide spectrum of bridging objects forms.

However, it is difficult to find the optima when looking for a system to allow a mostly industrialized construction using as few different elements as possible. In this endeavour, the investment possibilities force us to be even more rational.

Regarding all these facts it was decided to prefabricate the line segments. Such elements allow an industrial type construction with all the conveniences arising out of this method:

- the work conditions of the civil workers become equal as of the workers in factories,
- a high quality performance,
- permanent quality control,
- lower costs of the site organization,
- independence on the climate, season and weather conditions,
- reduced period of construction, as well as several other advantages.

Nevertheless, it is clear that the industrial type of construction has its deficiencies of both, technical and organizational nature.

In their wish to design a very wide spectrum of structures, the designers are restricted by the limited number of prefabricated forms. So they have to use the methods that would increase the universality of the prefabricated elements. The system used for the construction of the bridge in Maribor tries to satisfy these requirements in the following ways:

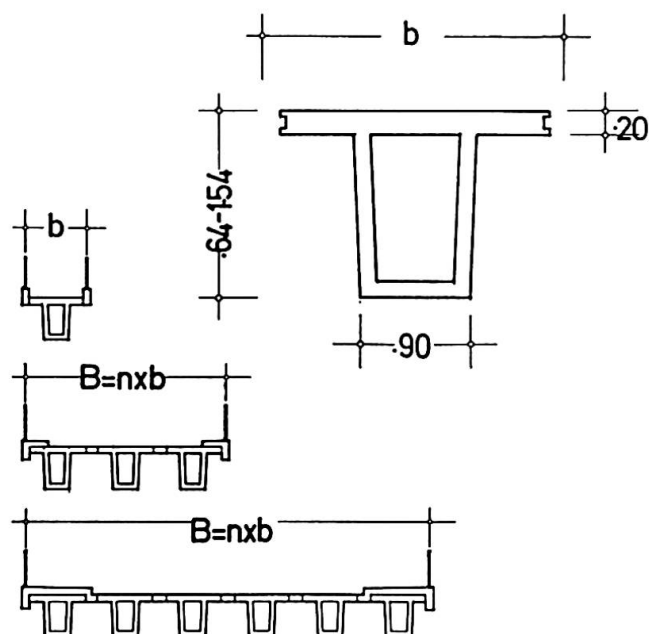

Fig. 3: Cross section of the box girder

- the selection of a line segment, that is a box girder with a wide upper flange representing the carriage-way slab after in situ concreting (Fig. 3);
- the height of the beam can be modified in the same formwork, thus allowing the adaptation to various spans and permissible heights of the structure and at the same time assuring a better economy;
- the beam can be produced with a full or hollow web depending on the type of the reinforcement (prestressed or unstressed steel), the type of loading (frequency and magnitude), and on possibilities of combination with other prefabricated or in situ concreted elements. The capability of the transport and erection equipment were also considered;

- in the statical systems, the above stated beams can be used as line systems or concreted into ribbed slabs (polyhedral shells) acting as simple supported, continuous or frame systems (Fig. 4).

The segments were connected using two basic technologies:

- grouting the segments with high strength synthetic (epoxy) bonding agents, and
- concreting wet joints of bigger or smaller sections.

The grouting procedure is used mainly for joining the single elements into beams. This method is particularly suitable for prestressed beams where the necessary contact stress during grouting is obtained by partial prestressing (Fig. 5 and 6).

Such a technology allows to divide the line beam into segments of desired length, taking into account the transportation and erection requirements.

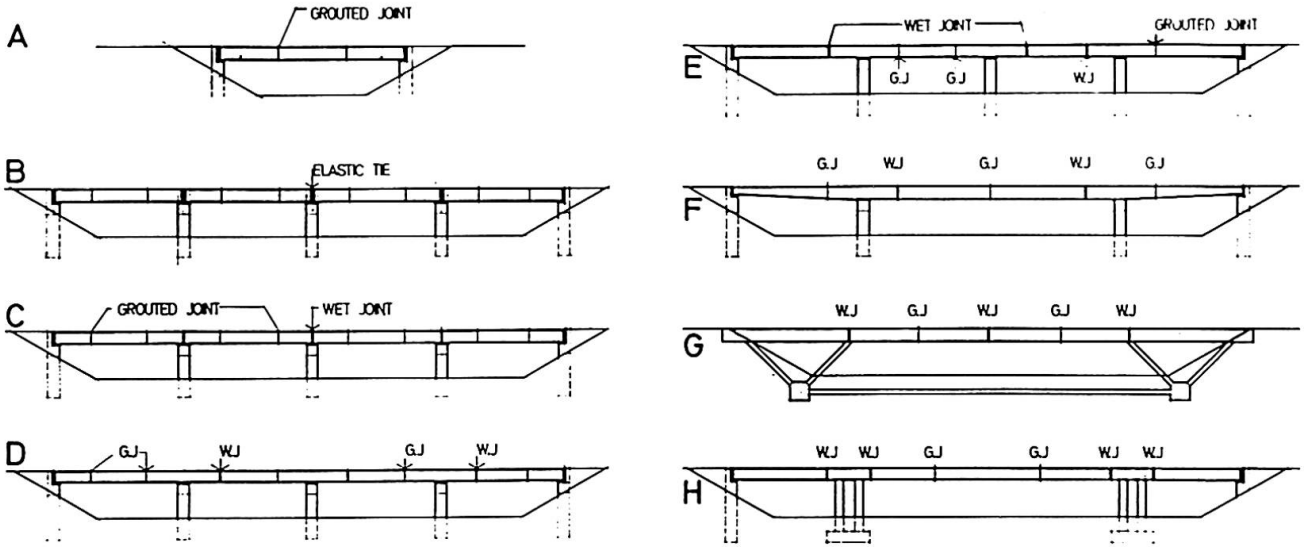

Fig. 4: Several possibilities of using the line segment in different static systems.

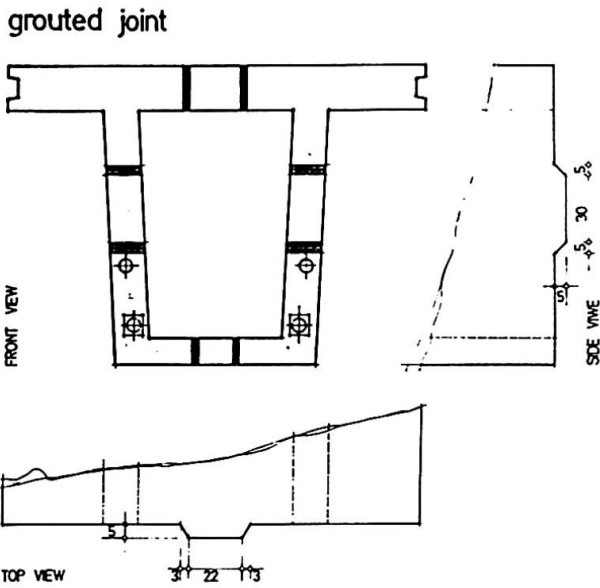

Fig. 5 : Execution of the grouted joint

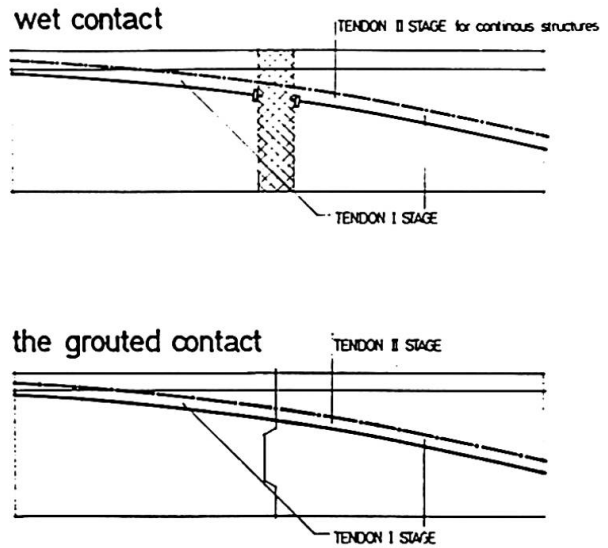

Fig. 6: Continuing of the beam with the grouted or wet joint.

Wet methods (i.e. in situ concreting) serve mainly for the longitudinal connection between beams, that means for formation of the carriageway slab with the possibility of width modification; for connection of the beams with other elements, e.c. cross elements, walls etc.; for erection of continuous elements that can be

adapted to vertical curves; and for in situ casting of temporary hinges after erection (Fig. 7 and 8).

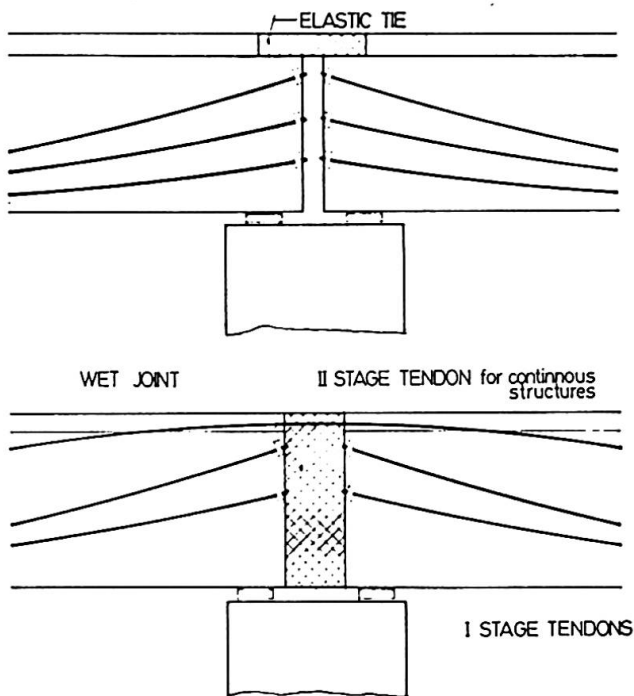

Fig. 7: Continuing of beams above the support.

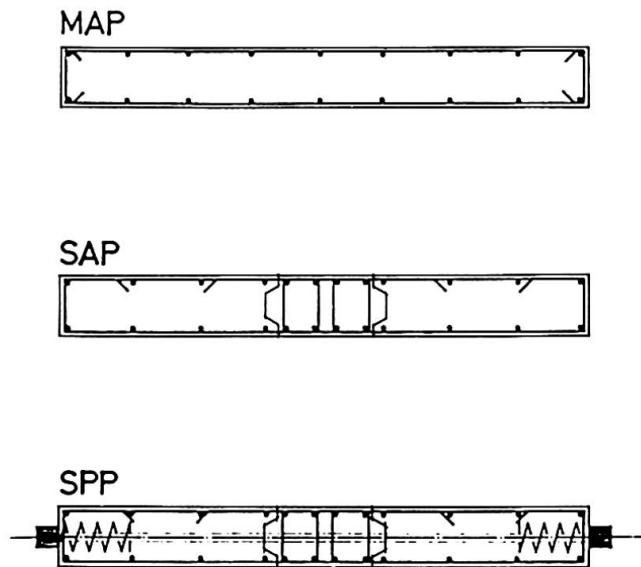

Fig. 8: Execution of the joint in the slab between the beams

All these joints are conventionally reinforced, and in prestressed systems also fully or partially prestressed.

The objects constructed according to the described system are conventionally reinforced or prestressed using a various percentage of the prestressing steel. Generally, the longitudinally prestressed beams are used, thus increasing the quality of jointing.

In the transverse direction - in slabs - the internal forces are carried by the reinforcement or by secondary transverse prestressing, using the tendons of smaller diameters.

Due to the specific form of the bridge in Maribor, several of the above described methods were used. In spite of their heterogeneity, these methods have caused no troubles to the constructors; on the contrary, in some aspects they even helped to accelerate the construction and make it cheaper.

The beams used for the bridge were 154 cm high, with the 20 cm wide flange - slab, and 33, 25 m long (Fig. 9 and 10).

The upper bridge consists of 10 beams with the axial spacing of 2,0 m, and the lower one of 8 beams having the axial spacing 2,50 m. The slab of the prefabricated segment is 1,70 m wide; so the in situ concreted longitudinal joint in the upper level is 30 cm wide and in the lower level 50 cm wide.

In the longitudinal direction, the bridge crosses the river in 6 spans as a continuous two-level frame; the upper bridge is extended into the viaduct with three spans of the same length as in the bridge.

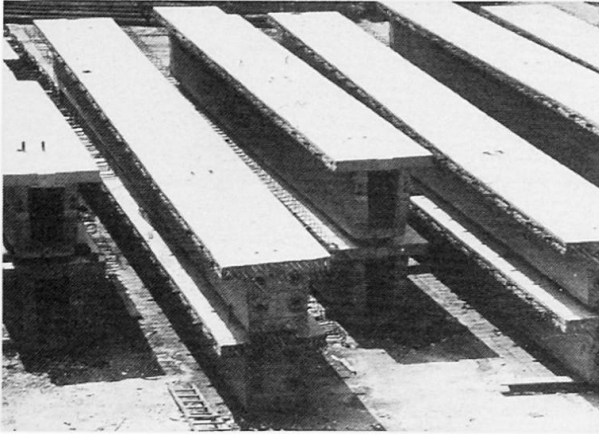

Fig. 9: Beams at the storage area.

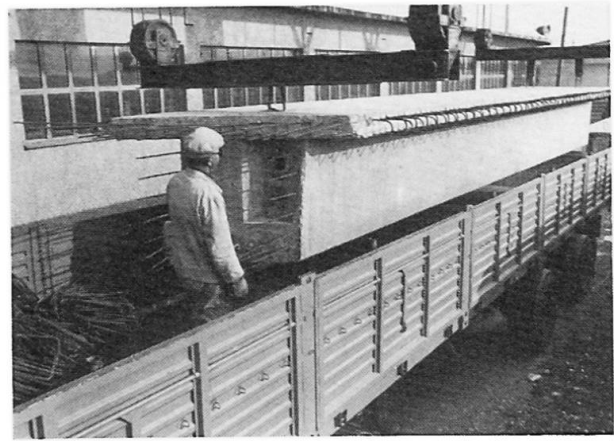

Fig. 10: Transportation to the site of construction.

The first phase of construction, foundations, were carried out using 8 bored piles of Benotto system for each support. The piles extended by round river piers carry the cross members of the lower bridge; on the piers there are columns carrying the cross members of the upper bridge. On the cross members there are suitable short brackets supporting the prefabricated beams. The beams were transported from the central fabrication shop, divided into three segments to be connected at the site with two-pack bonding agent (Fig. 11). Simply supported beams were prestressed using four tendons consisting of 24 parallel wires $\varnothing 7$ mm.



Fig. 11: Beams during grouting at the construction site.

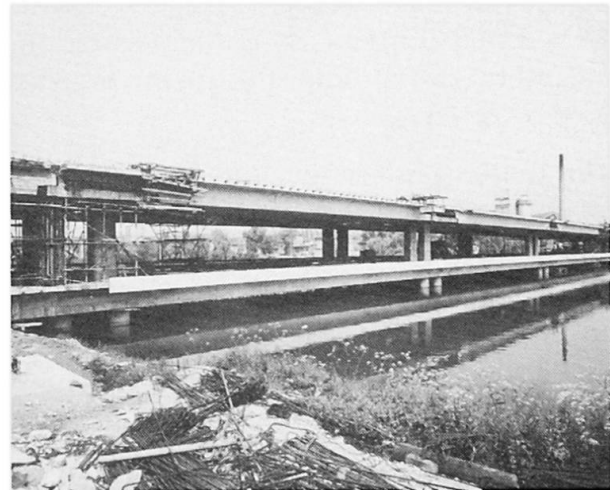

Fig. 12: The joint between the beam and the cross member before concreting.

The beams formed in this way have been put on the short cross member brackets and joined with the cross girders by in situ concreting. After that the longitudinal joints between the beams were concreted (Fig. 13).

This phase of construction was followed by second-phase prestressing, that is prestressing of continuous tendons consisting of 36 parallel wires $\varnothing 7$ mm. Each beam contains two such tendons. In the cross member of the central river pier the continuous tendons are lapped.

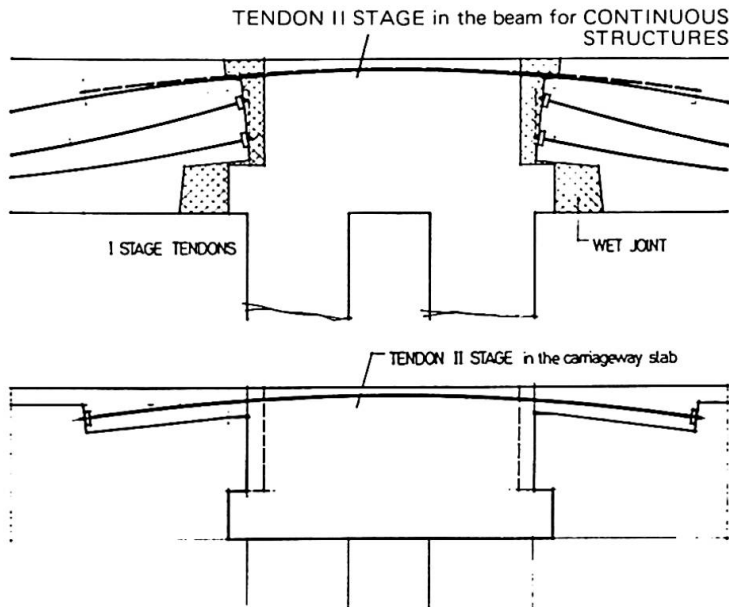

Fig. 13: Connecting of the beam with the cross member.

The negative bending moments above the supports are additionally carried by two tendons consisting of 16 \varnothing 7 mm wires; the anchorage of the tendons was successfully effected in the longitudinal joints between the beams (Fig. 13).

Taking into account the rather large spacings between the webs (boxes) of the beams, especially in the lower bridge where several ducts have to be drawn between the webs, the bridge slab carries large loadings arising out of the local wheel loads as well as of the load distribution from single beams to other beams.

Reinforcing of the slab and the slab joint would require a large percent of reinforcing, therefore the slab was prestressed with tendons consisting of 16 parallel wires \varnothing 7 mm, spaced for 80 cm (Fig. 15).

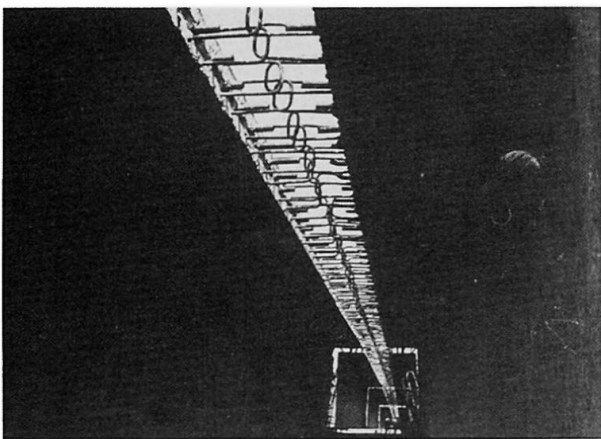

Fig. 14: The longitudinal joint before concreting.



Fig. 15: The tendons in the slab after anchoring.

In this way a better economy was achieved and at the same time also better quality and durability by eliminating some cracks; in our climate conditions the upper surface of the structure is namely much exposed.

Using all the methods that can be satisfactorily rationalized through their frequency we obtained an object that is well connected in the transverse and longitudinal direction; thus increasing our confidence in a longer serviceability of the structure.



In the static analysis the bridge was treated as space frame, taking into account that the slab acts as a polyhedral shell. In the static calculation this treatment was simplified into the model of the plain grid with the elements of a corresponding rigidity assuring a similar acting of both statical systems; the costs of the computerized calculation are lower. In general, several computerized investigations were made for the above described system of prefabrication; their correctness was proved by investigations on prototypes as well as by measurements on the completed objects.

Such investigations are reasonable as they make possible to simplify the statical analysis and to increase the economy in dimensioning the concrete sections and their reinforcement with bars and tendons.

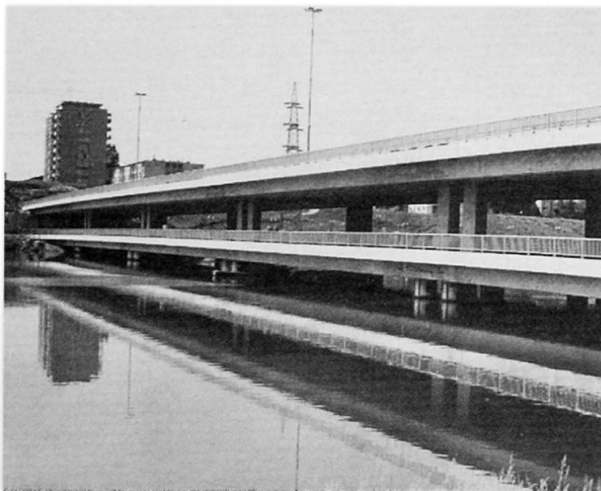

Fig. 16: View of the completed bridge

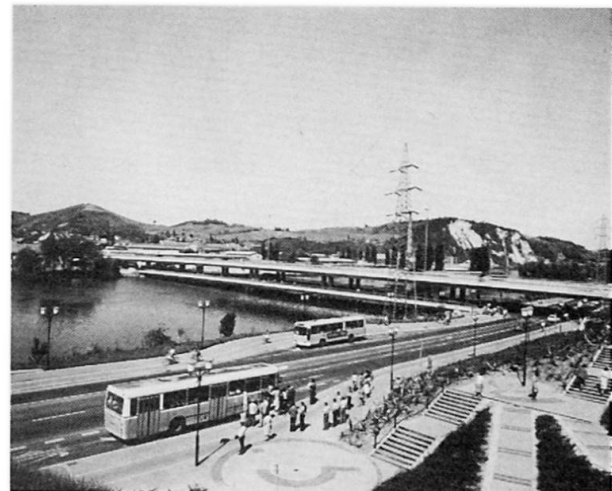

Fig. 17: The lower bridge has already been opened for the local traffic.

These investigations are still going on as the line segment system proved to be very convenient in our conditions of construction. New perceptions will be included into future explorations as well as the dimensioning methods existing in the world, yet taking into account the specific local conditions with the intention to construct the best objects in the most economic way.

Construction of the Usagawa Long-Spanned Concrete Arch Bridge

Construction d'un pont en arc, de grande portée, en béton

Herstellung einer weitgespannten Bogenbrücke aus Beton

Eiji NAKASIMA
Civil Engineer
Nihon Doro Kodan
Tokyo, Japan

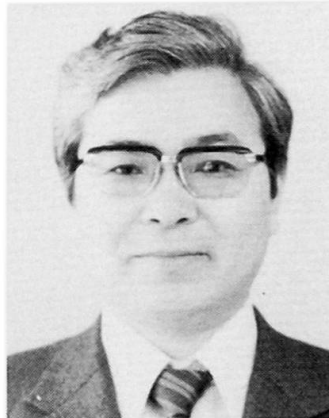

Born in 1937, graduate from Kumamoto Univ., Faculty of Civil Engineering. Civil Engineer for planning, design and supervision of Highway Projects at Nihon Doro Kodan for 25 years.

Michio UCHIDA
Civil Engineer
Nihon Doro Kodan
Tokyo, Japan



Born in 1944, graduate from Tokyo Univ., Faculty of Civil Engineering. Civil Engineer for planning, design and supervision of Highway Projects at Nihon Doro Kodan for 16 years.

SUMMARY

Usagawa Bridge, built by Nihon Doro Kodan (the Japan Highway Public Corporation) in 1981, is a reinforced concrete arch bridge with a span of 204 m. The result of application of flowing concrete to the arch ring of the Usagawa Bridge is discussed. This concrete, to which is added a water-reducing agent with high performance, was used for the purpose of enhancing the concrete workability and quality.

RESUME

Le Pont Usagawa construit par Nihon Doro Kodan (Corporation Publique Japonaise des Routes), en 1981, est un pont en arc d'une portée de 204 m. La mise en place du béton dans l'arche a été réalisé avec un plastifiant de haute efficacité, maintenant l'ouvrabilité du béton et améliorant sa qualité.

ZUSAMMENFASSUNG

Die Usagawa-Brücke, die von Nihon Doro Kodan (öffentliche Gesellschaft für Autobahnen in Japan) im Jahre 1981 gebaut worden ist, ist eine Betonbogenbrücke mit einer Spannweite von 204 m. Der Beitrag behandelt den Bau des Bogens, der – um eine bessere Verarbeitbarkeit und Qualität des Betons zu erreichen – unter Verwendung von Beton-Verflüssiger erstellt worden ist.



1. Introduction

Usagawa Bridge was constructed in 1981 as a part of the Chugoku Expressway. This bridge is a reinforced concrete arch bridge with 204m of an arch span. Since its arch ring has a large cross-section carrying four lanes (two lanes for each direction), various techniques have been incorporated in the designing, the quality control of materials and others to reduce the dead load. The arch ring was constructed with prestressed concrete using a cantilever method with temporary stays used prestressing bar together with a temporary steel girder arch. Having an experience in the construction of the same type of bridge with 145m of the arch span, Taishaku Bridge in 1978, the Japan Highway Public Corporation has realized the necessity of highly-workable concrete. Thus the flowing concrete was used with a view of enhancing the concrete workability and quality for the construction of Usagawa Bridge.

A water-reducing agent with high performance has been fairly utilized in the fields of concrete products and building construction as well, but it had not yet then brought results in the civil engineering field in Japan. Usagawa Bridge was the first case that a water-reducing agent with high performance was used on a full scale for a bridge with a long span.



Photo 1, Appearance of Usagawa Bridge

2. Structure Outline

The structure of Usagawa Bridge is shown in Fig. 1. The following are characteristics of the bridge:

- 1) A hyperbolic curve is used for the arch axis. The shape of the bridge is asymmetric and flat, (The span-rise ratio is 1/6 at the right bank and 1/9 at the left bank respectively.)
- 2) The arch ring carries four lanes and has 17.8m wide box section (3 cells) in order to improve the earthquake resistance in a transversal direction to the bridge axis. The girder depth varies from 3.6m at the crown to 4.4m at the springing.
- 3) At the crown, the arch ring and the upper slab are monolithicized to reduce the dead load as well as to make the arch rise as large as possible.
- 4) The upper deck is designed as prestressed concrete hollow slabs with 18m spans. Each of the two prestressed slabs carries two lanes.

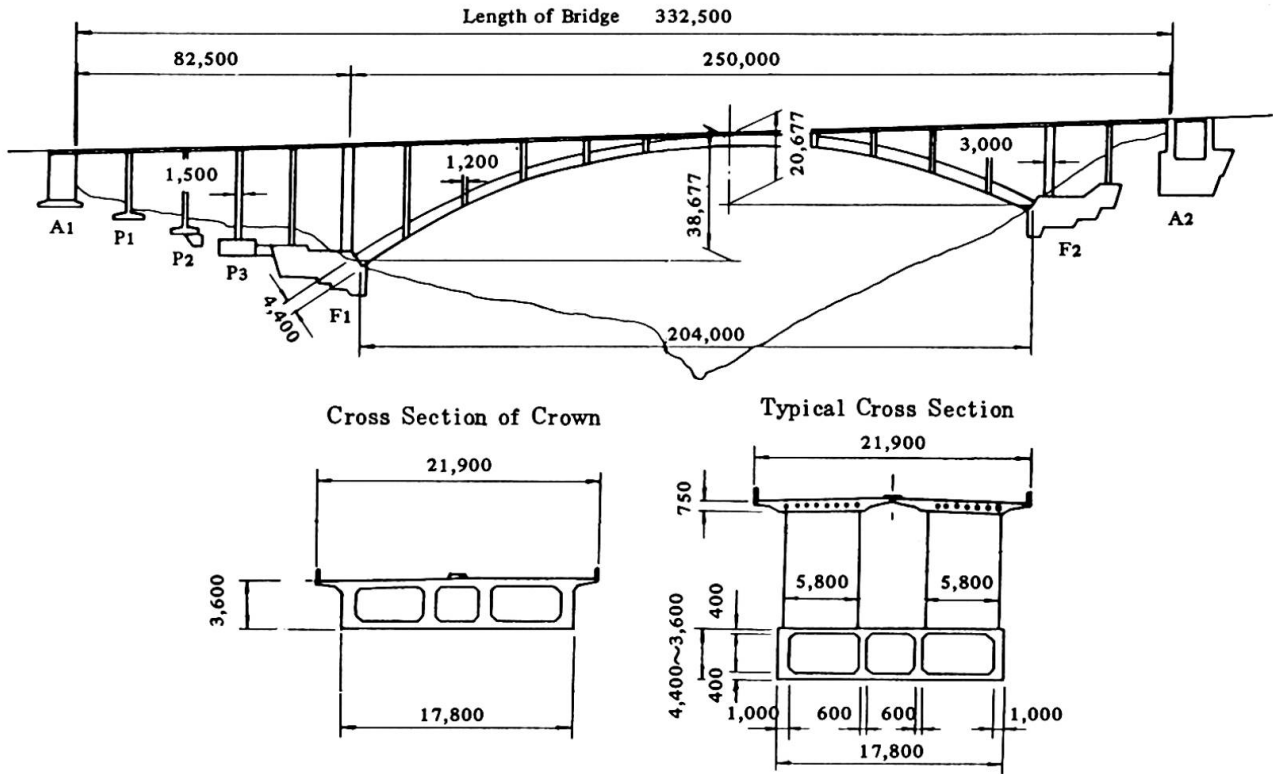

Fig. 1 General Arrangement

The following are principal materials used for Usagawa Bridge construction (includes principal temporary materials):

Concrete	41,300 m ³
Reinforcing bar (SD30)	2,150 t
Prestressing bar	690 t (for Temporary Works)
Steel girder arch	1,090 t (for Temporary Works)
Pylon column (steel)	121 t (for Temporary Works)
Rock anchor (SEEE F160)	4,089 m (for Temporary Works)

3. Construction Procedures

A cantilever method with temporary stays used prestressing bar and temporary steel girders were jointly used to build the arch ring (See Fig. 2).

- Step 1 First, arch abutment, abutment column and steel pylon on both side are built. Then, rock anchors are installed to secure the arch abutment against any movements during the arch ring construction. Next, the first section of 8m of the arch ring from the base is constructed on falseworks and a travelling form is assembled on the section.
- Step 2 For the next 50m sections from both the bases, every 4m block is built by the cantilever method with temporary stays used prestressing bar from abutment column. The travelling form is also used. Prestressing bars are arranged for the arch ring to relieve tensile stresses in the concrete during the construction.
- Step 3 For approximately 100m section in the center of the arch ring, first, steel arch members are installed by a cable erection method utilizing the steel pylons to finish the arch shape.



- Step 4 After removing temporary cable stays and pylons used for the construction of steel arch members, the steel arch members are covered with concrete by every 6m block using the travelling from to complete the concrete arch.
- Step 5 After building the vertical members on the arch ring, starting from both banks, each span of the upper slab is constructed one by one using steel girders as a falsework.

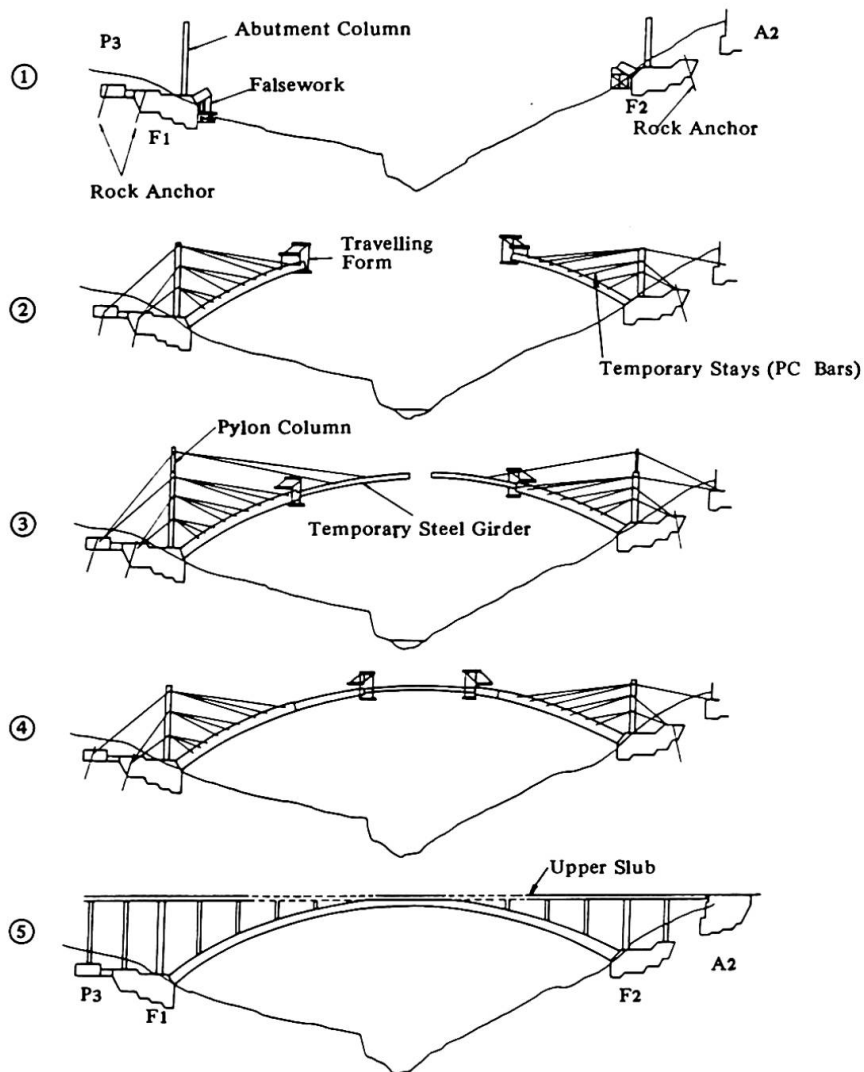

Fig. 2, Construction Process

4. Construction of Flowing Concrete

The 100m-long center section the arch ring is made up of blocks of 6m in length which was built using two large travelling forms. The following problems were observed at the time of concrete casting in the blocks:

- 1) As shown in Fig. 3, plate girder structures were placed inside the arch ring, and around them reinforcing bars and prestressing bars were intricately arranged making concrete casting difficult.
- 2) Because the arch ring was inclined and it required top covering forms at its top and bottom slabs of the box section, the positions for applying vibrators were limited. It was also difficult to visually confirm the condition of cast concrete.

- 3) The concrete volume of one block was 170m^3 and it was supposed to be too large for a usual construction by a travelling form. It was therefore necessary to enhance the concreting efficiency.

To solve the problems, application of high-workability concrete was needed. However, concrete with the design strength of 40 N/mm^2 with high-early-strength cement was used for this bridge. The cement content of the concrete was considerably large, which reaching $440\text{--}460\text{kg/m}^3$ if the slump value at the time of sending off from the plant were set at 9cm .

For the above reasons, to avoid adverse effects resulting from drying shrinkage, heat of hydration and etc., to control water and cement contents, and to obtain high-workability concrete, flowing concrete has been employed.

In applying flowing concrete, the mix proportions, the types and dosages of the superplasticizer and the slump increase were determined on the results of both laboratory and on-site tests, then concrete workability was confirmed and quality control items were selected.

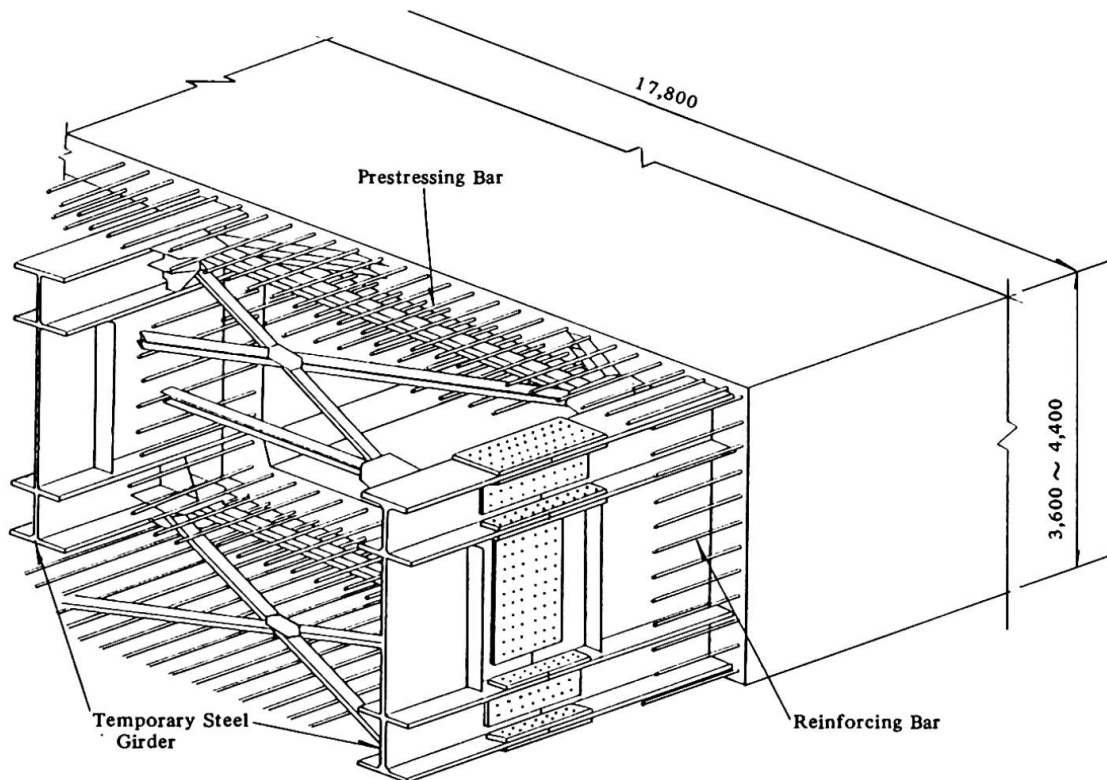

Fig. 3, Detail of Arch Ring

5. Mix Proportions and Production of Flowing Concrete

The proportions of the flowing concrete is shown in Table 1. Basic rules employed to determine the target slump value are as follows:

- 1) A slump value for the base concrete is set as small as possible: less unit water and cement contents are used. The slump value required for casting is obtained by adding superplasticizer. The slump increase is minimized but not to affect the concreting efficiency.
- 2) According to the on-site test results, good workability and dense concrete can be obtained when the slump value at the end of the delivery hose is a little more than 11cm . So, taking into consideration possible 2cm slump loss while pumpcreting, the slump value immediately after superplasticization should be 13cm or more.



- 3) To avoid segregation of the materials due to pumpcreting or excessive application of vibrators while casting, less than 16cm slump at its maximum after superplasticization is recommended, considering the fluctuation of the slump value.

Table 1, Arch Ring Concrete Proportion

Where to use	Cement (kg)	Water (kg)	Fine aggregate (kg)	Coarse aggregate (kg)	Slump (cm)	Air content (%)	Admixture (kind)
Cantilever	440	180	619	1,086	9±1.0(at a plant) 7±1.5(at casting)	4±0.5(at a plant) 4±1.0(at casting)	Water-reducing admixture
Steel girder arch	430	176	624	1,099	7±1.0(at a plant) 13±2.5(flowing concrete) 11±2.5(at casting)	4±0.5(at a plant) 4±1.0(flowing concrete) 4±1.0(at casting)	Water-reducing admixture + Superplasticizer

Note: "Flowing concrete" shows the values immediately after admixing the superplasticizer into the ready mixed concrete delivered to the site.

Based on the above rules, 7cm slump for the base concrete and additional 6.5cm target slump value for the flowing concrete have been determined. (See Fig. 4)

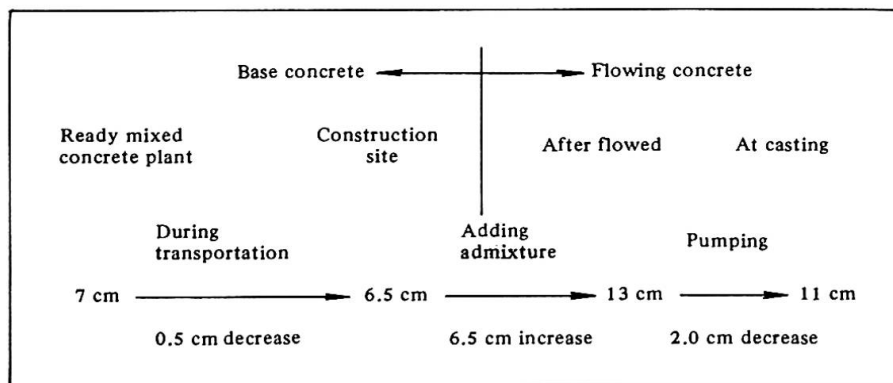

Fig. 4, Slump Change of Concrete

6. Concrete Casting

Superplasticizer was added on site right before casting of concrete to prevent a slump loss as could occur in a transportation time lapse.

The dosage of superplasticizer was fixed during the whole construction period to prevent errors resulting from complicated control regardless of atmospheric temperature or the slump change of the base concrete. The dosage of superplasticizer per truck mixer was measured by an automatic gauge and printed out on a recording machine each time, so as to prevent possible errors at the time of adding. After adding, concrete was agitated at a medium speed (18-20rpm) based on the test results.

It was known from the test results that a slump loss after superplasticization due to the time lapse can be recovered to the required slump value by re-adding superplasticizer. This method, however, requires prompt judgement on dosage and timely application. Moreover, it might confuse field control. Accordingly the concrete with an inadequate slump as a result of the time lapse or for other reasons was rejected.

The concrete for each block of the arch ring was cast first onto lower slabs, then web members and upper slabs. In particular, for the blocks of the steel girder arch section, smaller sized vibrators were applied at closer intervals with shorter vibration time in order to overcome the narrowness of the concrete-

casting space and avoid material segregation due to excessive vibrations. In addition, since the arch ring was inclined, the top covering up one by one as the concreting proceeded.

Concreteing was smoothly done by two concrete pumps, although the pumpcreting distance was as long as 300m in horizontal equivalent. Furthermore, the concreting efficiency was improved and casting time was considerably shortened and thus the concrete casting was easily done.

A volume of approximately 3,500m³ flowing concrete was cast for the period from the summer to winter. During the summer, coarse aggregates were kept cooled by underground water to lower the temperature of the mixed concrete. During the winter, on the contrary, by warming up mixing water within 30-35°C, the temperature of the mixed concrete was maintained above 10°C, and travelling forms were covered entirely with canvas and kept warm using jet heaters and others to cure concrete.

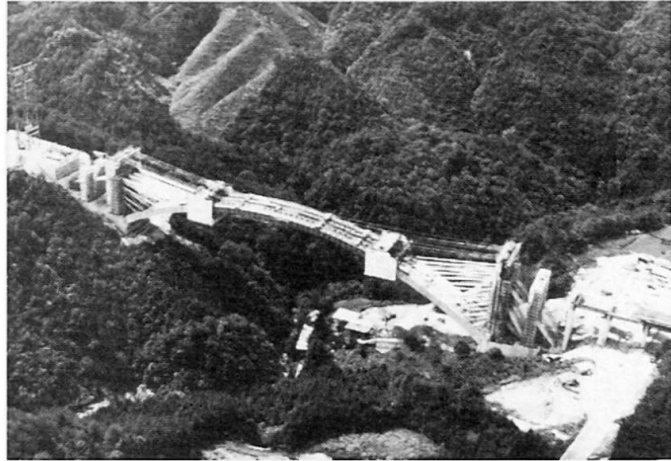

Photo 2, Construction of Arch Ring

7. Results of the Quality Control of Flowing Concrete

Quality control items for the concrete and frequency of testings or measurements of those items are shown in Table 2. Target strength at 28-day of the concrete was set at 46.4 N/mm². The slump value and the air content were based on the preliminary test results.

Table 2, Quality Control of Flowing Concrete

Stage	Test Items	Number of Testing Times			
		At Plant	Before superplastisized	After superplastisized	At casting
Stage 1 (Beginning of construction)	Workability	—	Observed visually every agitator truck		—
	Slump	Once a agitator truck (1st~5th) Once every 5 agitator truck (6th~)	Once a agitator truck (1st~5th) Once every 2 agitator truck (6th~10th) Once every 5 agitator truck (11th~)		Once every 5 agitator truck (for all agitator truck)
	Air content and temperature	Once a agitator truck (1st) Once per 50 m ³ (2nd~)			Once per 150 m ³
	Compressive strength	—	9 pieces per the first 50 m ³ After that: 9 pieces per 150 m ³	12 pieces per first 50 m ³ After that: 12 pieces per 150 m ³	—
State 2 (Quality was settled)	Workability	—	Observed visually every agitator truck		—
	Slump	Once a agitator truck (1st~5th) Once per 50 m ³ (6th~)	Once a agitator truck (1st~5th) Once every 5 agitator truck (6th~)		Once every 5 agitator truck (for all agitator truck)
	Air content and temperature	Once a agitator truck (1st) Once per 50 m ³ (2nd~)			Once per 150 m ³
	Compressive strength	—	9 pieces per 150 m ³	12 pieces per 150 m ³	—
Stage 3 (Usual control)	Workability	—	Observed visually every agitator truck		—
	Slump	Once a agitator truck (1st~5th) and once every 10 agitator truck (6th~)			Once every 10 agitator truck
	Air content and temperature	Once a agitator truck (1st agitator truck only)	Once a agitator truck (1st) and once 10 agitator truck (2nd~)		Once per 150 m ³
	Compressive strength	—	6 pieces per 1 block	12 pieces per 150 m ³	—

X Note: Figures in parentheses are ordinal number of agitator truck which arrived at site.



The results of the quality control tests are as follows:

The average value actually measured of the additional slumps by the superplasticizer was 6cm, while the target value had been set at 6.5cm. It proved that the concrete was superplasticized to the prescribed level. Furthermore the fluctuation of the slump value after superplasticization was 0.57cm in standard deviation. This preliminary test results. The air content was 0.5% higher than that of the base concrete and not much fluctuation was observed. The strength of the flowing concrete was a little lower than that of the base concrete. Most of the flowing concrete, however, was above the target strength.

Table 3, Results of Measurement at the Time of Construction

	Slump (cm)			Air content (%)			Increase of slump (cm)	Compressive strength (N/mm ²)	
	Before transporting	Before adding	After adding	Before transporting	Before adding	After adding		Before adding	After adding
Number of samples	159	162	162	72	81	86	162	23	33
Average	7.9	7.5	13.5	3.8	3.7	4.0	6.0	50.1	49.1
Standard deviation	0.336	0.500	0.571	0.263	0.313	0.248	0.686	3.06	2.94
Fluctuation coefficient	4.3	6.7	4.2	6.9	8.5	6.2	11.4	6.1	6.0
Maximum value	8.5	8.5	15.0	4.2	4.6	4.6	8.0	57.2	54.2
Minimum value	6.5	6.0	12.5	3.3	3.2	3.1	4.5	45	43.1

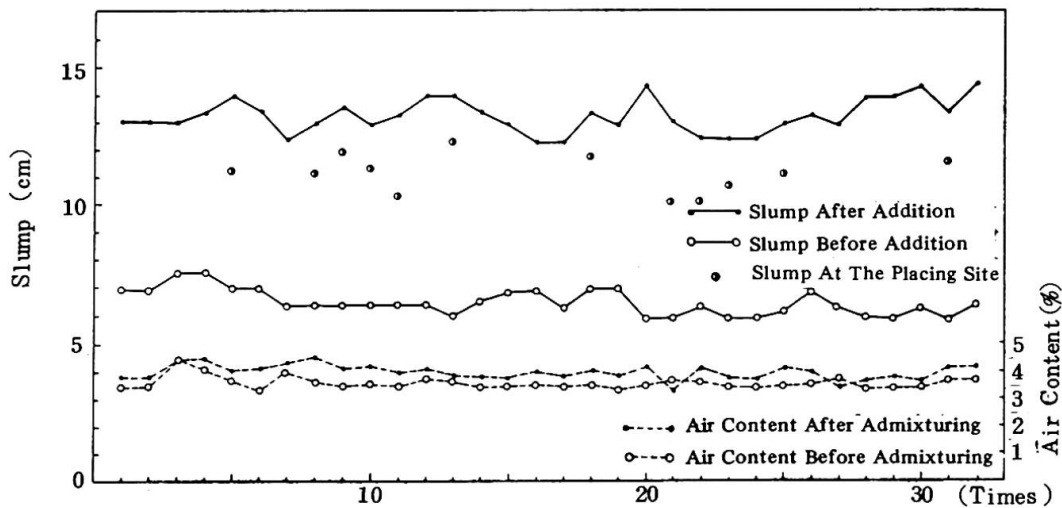

Fig. 5, Slump and Entraining Air Content

8. Conclusion

Having examined the execution results of the flowing concrete used for Usagawa Bridge, we are confident that the flowing concrete has not caused any troubles with the quality and workability of the concrete nor affected the concreting efficiency, but has brought excellent results beyond our expectation.

As to the concrete casting methods, there has been a trend on the increase in a quantity of concrete at a time using a pump, which calls for the improvement of pumpcreting efficiency.

Moreover, it has become more difficult to fill the structure with a low slump concrete, for reinforcing and prestressing bars are more densely placed in the structure as the bridges have become larger and longer.

Therefore, a high-workable concrete with high quality are increasingly needed. Consequently, we need more experiences in using such flowing concrete as used for Usagawa Bridge, to present standards for this type of concrete. We hope that a flowing concrete will be used extensively in the future.

New Bridge Across the Vltava in Prague

Nouveau pont sur la Vltava à Prague

Die neue Moldaubrücke in Prag

Jiří HEJNIC

Chief Engineer
Inst Traffic & Struct. Eng. Design
Prague, CSSR



Jiří Hejnic, born 1935, received his civil engineering degree from the Czech Technical University in Prague, Czechoslovakia, in 1958. In 1976 he was awarded a PhD for his work on thermal stresses in concrete bridges. He has designed several large prestressed concrete bridges built in Czechoslovakia.

SUMMARY

A big and very irregular prestressed concrete bridge across the river Vltava, in Prague, is at present under construction. The paper presents information concerning the design, structural analysis, model tests and construction of the bridge. Some interesting results of measurements made during the construction are also included.

RESUME

Un pont en béton précontraint, de forme très irrégulière, sur la rivière Vltava est en construction à Prague. L'article présente le projet, l'analyse structurale, les essais sur modèle et la construction du pont. Certains résultats intéressants de mesures en cours de construction sont aussi mentionnés.

ZUSAMMENFASSUNG

In Prag wird eine grosse und sehr unregelmässig geformte Spannbetonbrücke über die Moldau gebaut. Der Beitrag umfasst eine Beschreibung der Brücke, die Ergebnisse der statischen Berechnung und der Modellmessungen sowie den Bau der Brücke. Einige interessante Ergebnisse der Kontrollmessungen auf der Baustelle werden zusätzlich gezeigt.



1. INTRODUCTION

As other European big cities the capital of Czechoslovakia, Prague, is building its transport system, too. The problems of automotive transport is being solved by construction of the basic highway system. The overall length of roads incorporated into this system will exceed 200 km and will be longer than, for example, the completed Prague - Brno motorway. By the end of 1983 more than 63 km were already in use, the most important of which was the North - to - South Expressway, linking up with the operating D 1 (Prague - Brno - Bratislava) motorway in the South and the designed D 8 (Prague - Ústí n. L.) motorway in the North.

At present the greatest importance for Prague traffic has the East - to - West connection which is under construction now. The most complicated and costly structure of this part of the system is the new bridge across the Vltava below the Barrandov Hill having the name of Antonín Zápotocký, the former president of the Czechoslovak Socialist Republic. The bridge will be of great importance also for further development of the City which has been spreading for decades southwards along the Vltava. During this period major housing estates have grown in this territory but in spite of this development, however, the river Vltava has remained an obstacle for the highway traffic at a distance of almost 12 km.



In the period 1971 - 1977 the Institute for Traffic and Structural Engineering Design prepared a number of variants of the central ring in this sector, including also 13 alternatives of a bridge across the Vltava. The resulting, thirteenth variant, whose initial design was prepared in 1977, subordinates its form fully to the traffic engineering design (Fig.1).

Fig. 1 - Photo of the architectural model of the bridge

2. DESCRIPTION OF THE BRIDGE STRUCTURE

The extent of the Antonín Zápotocký Bridge is determined by the width of the Vltava river bed and the highways on both bridgeheads, the skew of the crossing and the width of the bridge itself. Structurally the bridge has been designed as a continuous six span girder spanning $34,66 + 61,00 + 71,00 + 72,00 + 66,00 + 45,99$ m (Fig.2). Along the major part of its length the width of the bridge is variable in accordance with the alignment of the individual lanes branching off the bridge. However, even the smallest width of 40 m means that Antonín Zápotocký Bridge, with four lanes in each direction and pavements on both sides of the bridge, will be the widest of Prague bridges.

Both halves of the bridge, representing separate superstructures, have different plans determined by the traffic engineering design, and are supported by common piers whose form corresponds with structural, technological and architectural requirements. The upstream half of the bridge is joined by a two span ramp connecting the left bank Chuchle radial with the central ring. The actual Vltava river bed is overcome by three main spans (71+72+66 m) at an angle of $53^{\circ}26'$.

The depth of the superstructure is constant - 3.0 m - along the major part of its passage across the Vltava river bed. The depth of the remaining part is variable from 3.0 m to 1.6 m in the place over the abutments. The haunch is so

designed that the planes, in which the depth of the superstructure is constant, are perpendicular to the axis of the central ring regardless of the continuously variable skew of the bridge. Both halves of the bridge superstructure have a box cross section with four webs of a constant thickness of 60 cm; the ramp has a box cross section with two webs 80 cm thick. The upper flange of the box girder is 23 cm thick in the more regular part of the bridge; in the ramp with a clear width of 6.30 m the thickness rises to 35 cm. The thickness of the lower flange increases from 15 cm towards the supports to 90 cm in the haunches.

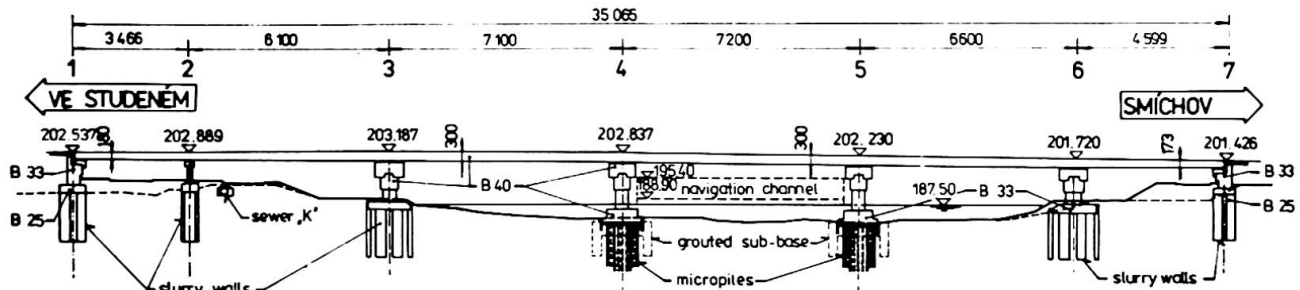

Fig. 2 - Longitudinal section along the bridge axis

While the design of the superstructure has been more or less conventional, the form of the four main piers both in the river bed and on both river banks designed by Ing. arch. Karel Filsak in unusual, while fully complying with the requirements imposed on the substructure of this bridge. The piers meet the Vltava water level or the ground level by a rounded shaft, supporting an oversized prestressed concrete capping beam following the direction of the river flow and river banks respectively (Fig. 3). The superstructures are supported by four bearings, supported, in turn, by bearing walls, perpendicular to the capping beam direction. Apart from visually relieving the superstructure and equalizing the differences in height, longitudinal gradient and transverse pitch of the bridge deck, these bearing walls have also an important structural function by decreasing the skew of the bridge bearing.

The superstructure and the major part of the piers is of Class 40 concrete, mild steel reinforcement of class 10 425 in dia. from 10 mm up to 32 mm. Prestressed concrete reinforcement consists of steel cables of 1 dia. 5,5 mm and 6 dia. 5,00 mm tempered steel wires. The tendons, consisting of 12 dia. 15,5 mm cables, have a nominal load bearing capacity of 2 000 kN. Vertical prestress of pier capping beams and the webs of the superstructure and the longitudinal prestress of the bridge deck flanges above supports will be ensured with dia. 32 mm prestressing bars of class 10 607 steel. In transverse direction the superstructure is not prestressed, being designed as a reinforced concrete structure.

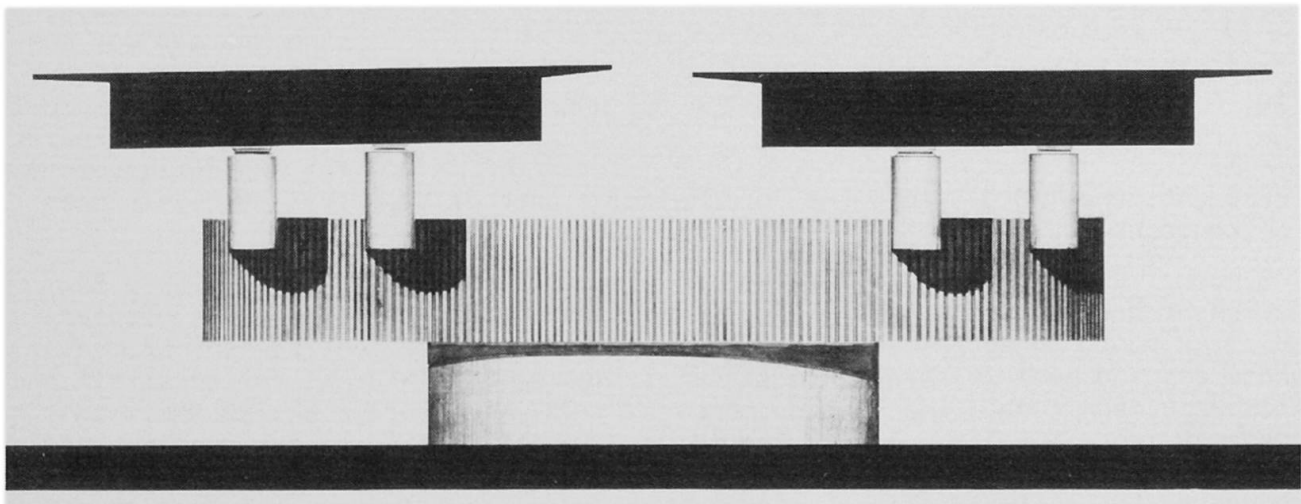

Fig. 3 - Architectural view of the bridge pier with superstructure

3. STRUCTURAL DESIGN

For the purpose of a detailed structural analysis it was necessary to define first mathematically the complex form of the bridge structure in space, i.e. to formulate a digital model of the bridge. For this purpose a general program for a 9825 T Hewlett Packard calculator was prepared to solve, on the one hand, the calculation of the coordinates of bridge edges, and that of structural characteristics of cross sections on the other, and, finally, to draw the individual cross sections on a plotter (Fig. 4). More than 650 such drawings were used directly as shuttering drawings in the phase of working drawing design.

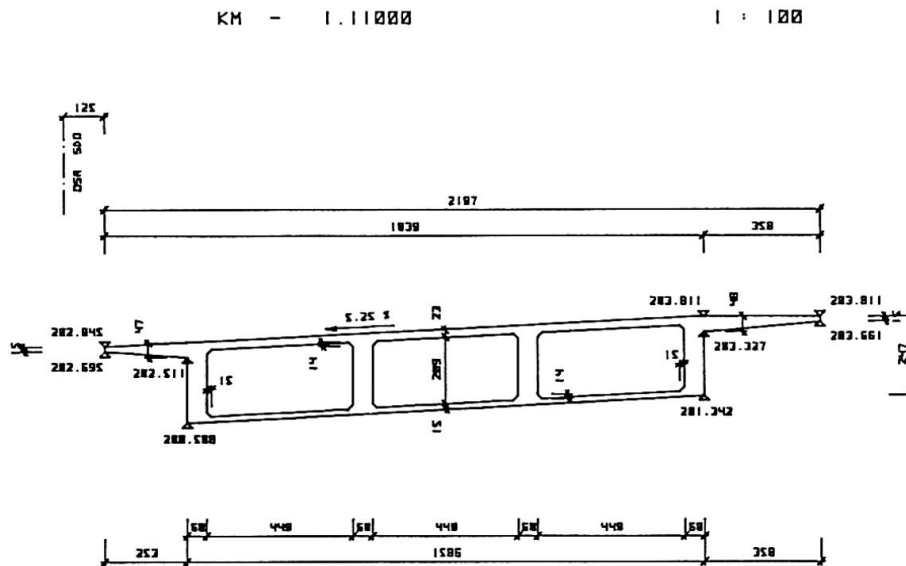

Fig. 4 - Cross section drawing generated on the HP 9825 T plotter

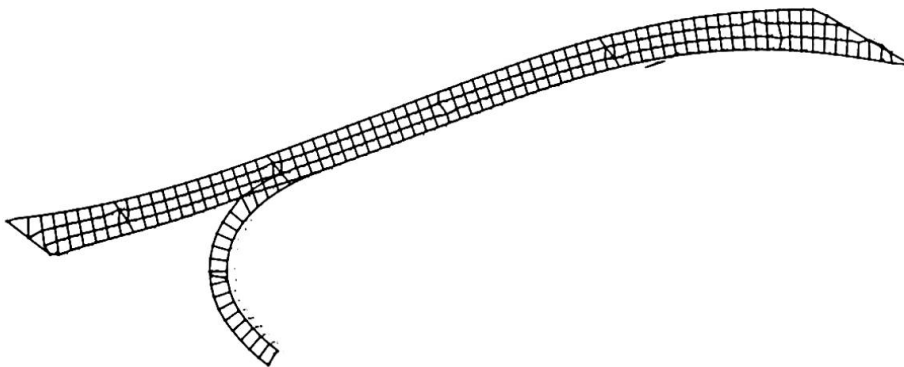

Fig. 5 - Statical scheme of a grillage for one superstructure

Structural analysis was elaborated by several methods and supplemented with model tests and measurements. One superstructure was replaced with a grillage of 360 nodes and 610 bars, solved for more than 200 loading stages (Fig. 5). To create the most effective combination of loading states a special program was prepared. The most irregular parts of the structure, such as the first right bank span, the ramp and its connection with the bridge structure, were designed by the finite element method. With regard to the irregularity of form and the necessity of the solution of the bridge as a spatial structure a new program system was devised. For the design of Antonín Zápotocký Bridge a technological line was set up, consisting of Hewlett Packard 9825 T calculator for data preparation and design of reinforcement, the IBM 370 computer for the major part of structural analysis and the Kongsberg DC 300 plotter for graphic output.

The number of unusual tasks involved in structural analysis included also the design of prestressed concrete capping beams of bridge piers. In case of pier No. 5, situated near the connection of the ramp with the central ring bridge, whose capping beam is stressed most of all beams, the internal forces attain the following magnitudes: the bending moment $M = 307 \text{ MNm}$, torque $K = 22 \text{ MNm}$, and shearing force $T = 55 \text{ MN}$. The extraordinary forces applied to the capping beam are also reflected by its dimensions: height 5,0 m, width as much as 4,2 m. With regard to the state of stress of the structure and reinforcement arrangement it was necessary to concrete the beam without working joints; the almost 600 cu.m.

Structural analysis was elaborated by several methods and supplemented with model tests and measurements. One superstructure was replaced with a grillage of 360 nodes and 610 bars, solved for more than 200 loading stages (Fig. 5). To create the most effective combination of loading states a special program was prepared. The most irregular parts of the structure, such as the first right bank span, the ramp and its connection with the bridge structure, were designed by the finite element method. With regard to the irregularity of form and the necessity of the solution of the bridge as a spatial structure a new program system was devised. For the design of Antonín Zápotocký Bridge a technological line was set up, consisting of Hewlett Packard 9825 T calculator for data preparation and design of reinforcement, the IBM 370 computer for the major part of structural analysis and the Kongsberg DC 300 plotter for graphic output.

of Class 40 concrete had to be placed in a continuous process, without any interruption. Since the contractor could not ensure the cooling of the concrete mix or its components, it was necessary to analyze also the state of stress of the structure due to the development of hydration heat.

4. MODEL TESTS

In the time of the preparation of working drawings three models of parts of the bridge were also manufactured and tested. The reason for it was the extremely irregular form of the superstructure, complexities of load combinations and the overall arrangement of the piers as well as the new method of structural analysis. The model tests were intended to verify the correctness of assumptions of structural analysis, ascertain the actual state of stress and strain of the superstructure and the limits of load bearing capacity of the bridge pier. Altogether two models of the most irregular parts of the superstructure were made of resin concrete and one model of the bridge pier of cement concrete.

The models of the superstructure on the scale 1 : 30 were not prestressed and were tested only in regions of permissible stresses of the model material for design loads. The resin concrete used made it possible to manufacture models of very complex shapes at good workability and without the origin of dangerous internal stresses or volume changes. The unfavourable effects of creep were reduced in model tests to the minimum by the selected load magnitude and the organization of tests. The load was applied, on the one hand, in the form of concentrated loads, and in the form of surface loads on the other. The model loading and the test evaluation was ensured by the Building Institute of the Czech Technical University, Prague (Fig.6).

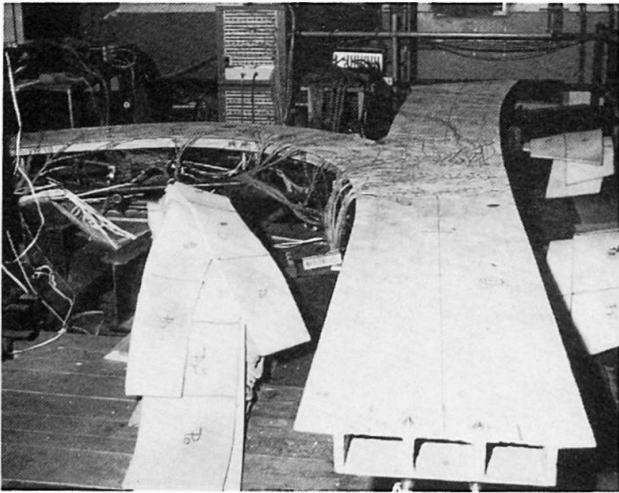

Fig. 6 - One model of the superstructure of resin concrete

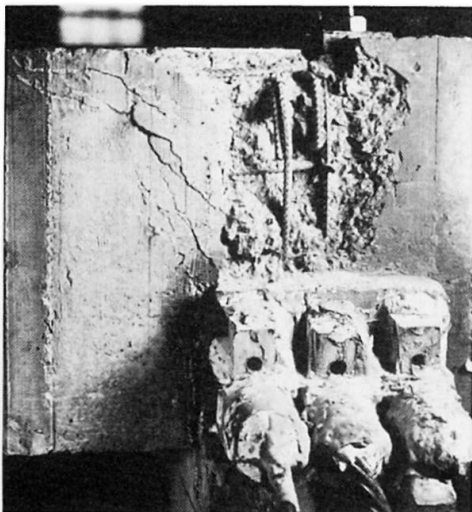

Fig. 7 - Crushed bearing wall after pier model test

The pier model on the scale 1 : 10 was prestressed with cables and bars analogously with the pier prototype and loaded until failure. The capping beam of the model was prestressed with 9 dia. 15,5 mm single cables, and 4 dia. 12,5 mm wire cables which replaced the tendons with a smaller diameter of curvature. The region between the bearing walls and the outer bearing wall were further prestressed vertically with dia. 10,5 mm bars of Class 10 607 steel, similarly as the piers, to reduce the effect of torsion and transverse flexure. The loading test of the model was carried out by the Building Research Institute in Veselí n. L.

The model failed under the combination of crushing of the outer bearing wall and its shearing - off along the capping beam surface (Fig. 7). Almost simultaneously also the load bearing capacity of the capping beam was exhausted, which was destroyed above the pier shaft by mighty horizontal cracks and began to crush in its lower part.

The loading test of the model has proved that dimensions of the pier, its pre-



prestressed and mild steel reinforcement were correctly designed and its parts have approximately identical load bearing capacity. The tests ascertained the following most important factors:

- safety margin against ultimate strength $s = 2,64$
- cube strength of Class 40 concrete after 83 days from manufacture = $42,8 \text{ N/mm}^2$

The model tests have proved the principal agreement of structural design with the test results and have confirmed the safety of the designed structure. A detailed description of the tests, their principal results and their use for the bridge design have been described in [1].

5. CONSTRUCTION

With regard to the irregular shape of the bridge the whole superstructure is concreted on steel centering. For both the design and the contractor the irregular form of the bridge meant increased labour requirements, in the case of construction imposing also high requirements on deficient professions of carpenters and reinforcement makers.

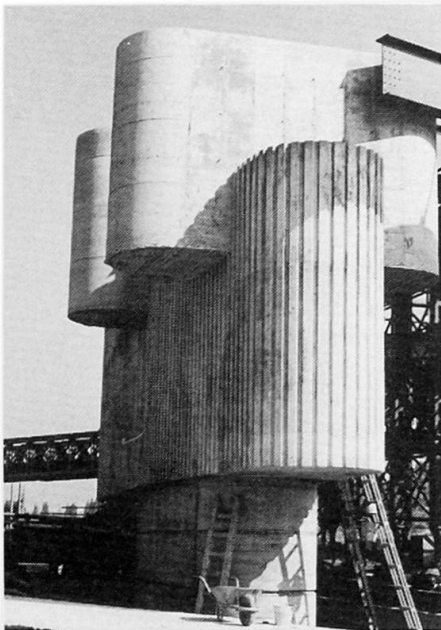

Fig. 8 - Ramp pier on the left hand river bank

The work on the site began in July 1978 by founding two river bed piers and, subsequently, by founding abutments and both river bank piers. The river bed piers are founded on a pile frame of micropiles, built in a double cofferdam under the protection of two-phase grouting consisting of a clay - cement and subsequently chemical mix on the basis of water glass and ethyl acetate. The piers and abutments on both Vltava river banks are founded on slurry walls 80 cm thick. In the construction of the bridge substructure the high quality of work and the manufacture of architectural concrete of various textures were accentuated. By autumn 1981 the reinforced concrete piers and abutments were completed, as seen in Fig. 8 showing the ramp pier on the left river bank. The labour requirements of the four prestressed capping beams of the river bank and river bed piers are considerably higher than those of analogous reinforced concrete structures.



Fig. 9 - Construction phases of the superstructure

The construction of the superstructure proceeded from all three abutments continuously. The concreting was carried out in three phases successively - the lower flange, the webs and diaphragms of the box girder, and finally the upper flange of the bridge deck with cantilever ends. The concreting proceeded to the length of one construction phase, corresponding with the length of the span between the cross sections of zero bending moments due to the dead weight of the structure. The individual operations were coordinated in time so that at least two spans were in construction and the teams of specialized workers could pass from one workplace to another (Fig. 9). The site of the upstream half of the bridge superstructure was serviced from a temporary steel bridge connecting both river banks. After the

completion of one half of the bridge it is used for both public and site transport, and the supports of the temporary bridge are used to support the centering for the concreting of the downstream half of the bridge.

With regard to construction the organization of concentrated concreting is worth mentioning. In the course of these operations the volume of Class 40 concrete placed in one operation attains as many as 600 cu.m.. The concrete mix contains a plastifier with retardation effect, called Ralentol.

After its first use in the construction of the motorway bridge in Beroun the new Mono 2 000 kN prestressing system was used in the construction of the Antonín Zápotocký Bridge. More than 360 kilometres of dia. 15,5 mm cables of this system were successfully applied and prestressed in the piers and the superstructure. For vertical prestress by means of dia. 32 mm bars of Class 10 607 steel the grout-free technology was used to reduce the labour requirements, based on the nut and bolt anchorage of bars, which are provided with a coating on the basis of atactic propylene, protected with polyethylene foil to prevent the bond between prestressing reinforcement and concrete and to protect the bars from corrosion. This technology was used for the first time in Czechoslovakia.

6. EXPERIMENTAL RESEARCH

According to the irregular form of the bridge and the new methods of structural analysis, not only model tests but also experimental research of strains, stresses and temperature was carried out on the Antonín Zápotocký Bridge during the construction and in the time of the static loading test. The observations enable the verification of the assumption of structural design of the bridge as well as the assessment of the load bearing capacity of the structure in its performance. In four prestressed main piers (in the river bed and on both river banks) and in the superstructure 518 acoustic strain gauges and 256 acoustic thermometers were built. In the superstructure the strain gauges and thermometers were fitted in 18 characteristic cross sections of the structure. The creep and shrinkage of



Fig. 10 - Completed half of the bridge under test loading

concrete was observed directly in the piers and in special large specimens concreted of concrete mixes from the characteristic parts of the construction phases of the superstructure. The strain gauges built in these sections were used for the determination of the moduli of elasticity of concrete, too. For measurements of creep and moduli of elasticity hydraulic jacks built in piers and control specimens were used.

The measurements of hydration heat made on the piers and abutments, where about 600 cu.m. of concrete were placed in continuous process, showed principal agreement with the values of heat distribution obtained from the calculation. Experimental

research made in the time of prestressing the Mono 2 000 kN tendons and during decentering had to control the state of deformation as well as the state of stress, and was used also by the contractor for precise planning the constructional phases. Before the static loading test measurements of values of the moduli of elasticity of superstructure were made, the mean value being $32\,350\text{ N/mm}^2$ for the stress of $3,3\text{ N/mm}^2$ and $31\,417\text{ N/mm}^2$ for the stress of $6,6\text{ N/mm}^2$. The stresses during the loading tests can be obtained directly from



the strain values, as in short time measurements concrete creep and shrinkage can be neglected. Also the temperature changes were measured with maximum value of $0,6^{\circ}\text{C}$, which corresponds the change of strain $0,3 \cdot 10^{-6}$ which is under the precision of strain gauges used.

In the time of the static loading tests eight test loading positions were studied. One of them with 30 trucks in both largest spans is shown in Fig. 10.

The deformations for the test loadings were calculated by the designer using the same grillage scheme for the superstructure as in structural analysis. The measured values of deformations were similar to the calculated, the mean value of this ratio being 0,901. The strains were measured in 18 cross sections of the superstructure for all 8 test loading positions. An example of calculated stresses from measured strains for the last left bank span is on Fig. 11, where the values in brackets

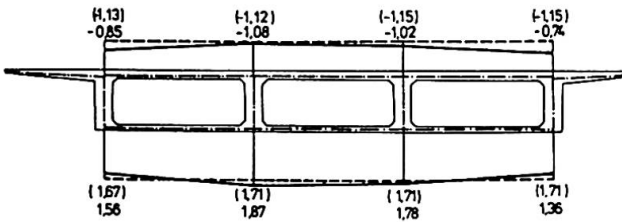

Fig. 11 - Measured and calculated stresses for test loading

show the comparison with structural design values. In structural characteristics of the bridge the cornices and other parts of reinforced concrete were not calculated, and so the results of stresses in the upper flange are measured smaller than calculated. The measurements have proved a good agreement with design assumptions.

7. CONCLUSION

The Antonín Zápotocký Bridge is the biggest bridge under construction at present in the framework of the basic highway system of Prague. Although - with regard to the approved traffic engineering design - it was impossible to apply any of the newly developed, progressive construction methods, it was an endeavour of all partners in this project to create a work which could represent with dignity the contemporary period of development of the capital of Czechoslovakia.

REFERENCES

1. HEJNIC J., DOLEŽAL M., Modellversuche für die neue Moldaubrücke in Prag, Bauingenieur, November 1982, 429 - 437

Development of Industrialized Building Production

Développement de la construction industrialisée des bâtiments

Entwicklung des Fertigteilbaus

Asko SARJA

D. Tech.

Techn. Res. Centre of Finland
Helsinki, Finland



Asko Sarja, born 1941, graduated in Civil Engineering at Oulu University in 1968, obtaining a D.Tech. at Helsinki Technical University in 1979. Entering Research in 1970 after several years' practical work in engineering design, he has since worked in the Concrete and Silicate Laboratory, becoming its director in 1978, in structural research and development.

SUMMARY

The evaluation of trends in prefabrication technology indicate that it will enter a decline phase within the next decade, which can be avoided only with immediately-undertaken innovative development. Precast concrete technology has many as yet unutilized potential assets which must be exploited. These changes are listed. Element systems must be developed further. Finnish open element systems for residential, industrial and commercial buildings are presented as examples of the possibilities that exist.

RESUME

Il semble que la technologie actuelle de préfabrication atteindra sa phase de déclin dans la prochaine décennie. Seul un développement innovatif entrepris immédiatement peut éviter une réduction de la part de marché. La technologie du béton préfabriqué présente certains avantages encore inutilisés et devant être mis en valeur. Ces changements sont mentionnés. Des systèmes d'éléments ouverts finlandais pour des bâtiments résidentiels, industriels et commerciaux sont présentés.

ZUSAMMENFASSUNG

Die Beurteilung der Wachstumstendenzen im Fertigteilbau zeigt, dass sich im nächsten Jahrzehnt ein Rückgang einstellen wird. Er kann nur mit unmittelbaren innovativen Entwicklungen verhindert werden. Viele Möglichkeiten der Fertigbautechnik sind bis heute ungenutzt und die Fertigteilbausysteme müssen weiterentwickelt werden. Im Beitrag wird darauf eingegangen und die offenen Fertigteilbausysteme aus Finnland für Wohn- und Geschäftsbauten werden als Beispiel vorgestellt.

1. EVOLUTIONARY TRENDS ON THE MARKET

1.1 Evaluation of the life cycles of prefabrication

The life cycle of a technical product or production system can be statistically evaluated using the same methods as for evolution in nature. This method is known as Darwin-Volterra methodology (3,4). The external conditions in nature correspond to the market conditions in techniques, and natural evolution corresponds to technical innovation.

The life cycle of a product or production technique consists of the introductory phase, growth phase, maturity phase, saturation phase and decline phase.

The prefabricated building production technique has a history spanning approximately 25 years, which is considered rather short in comparison with many other techniques. Several life cycle estimates for Finnish precast concrete production and German prefabrication are presented in Figures 1 to 3. The estimates are presented on the basis of statistics obtained for the years 1955 to 1965 and 1980 to 1982. Following the statistical period, the evolution curve is evaluated by means of the Darwin-Volterra methodology.

Finnish building production represents a small but very intensive market area within the observation time period. The German building production represents a large and intensive market area.

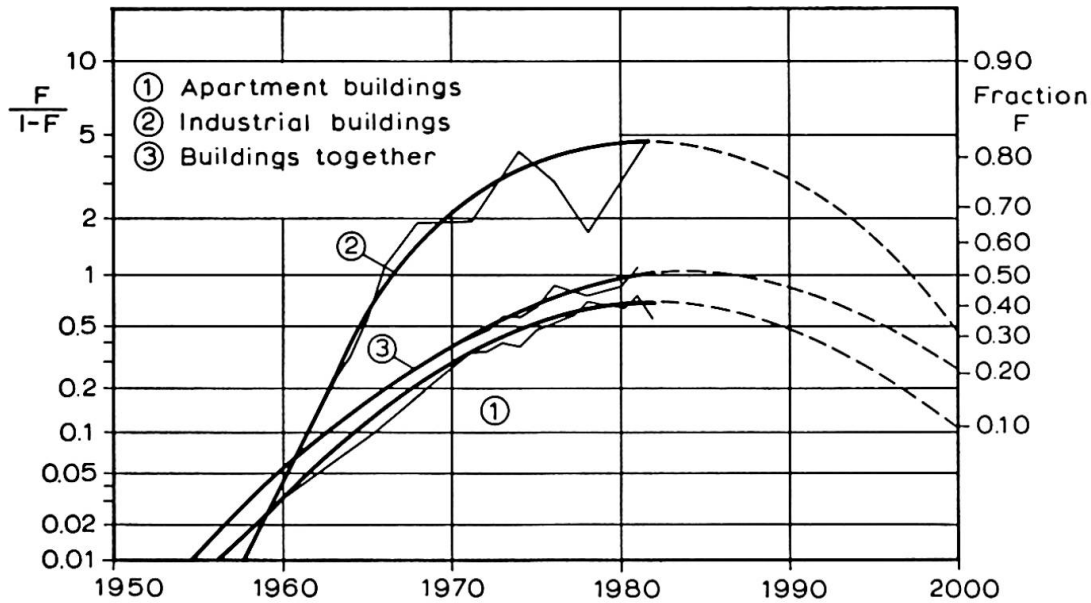

Fig. 1 Life cycle estimates of precast concrete production in Finland, illustrated by the market fraction evolution curve.

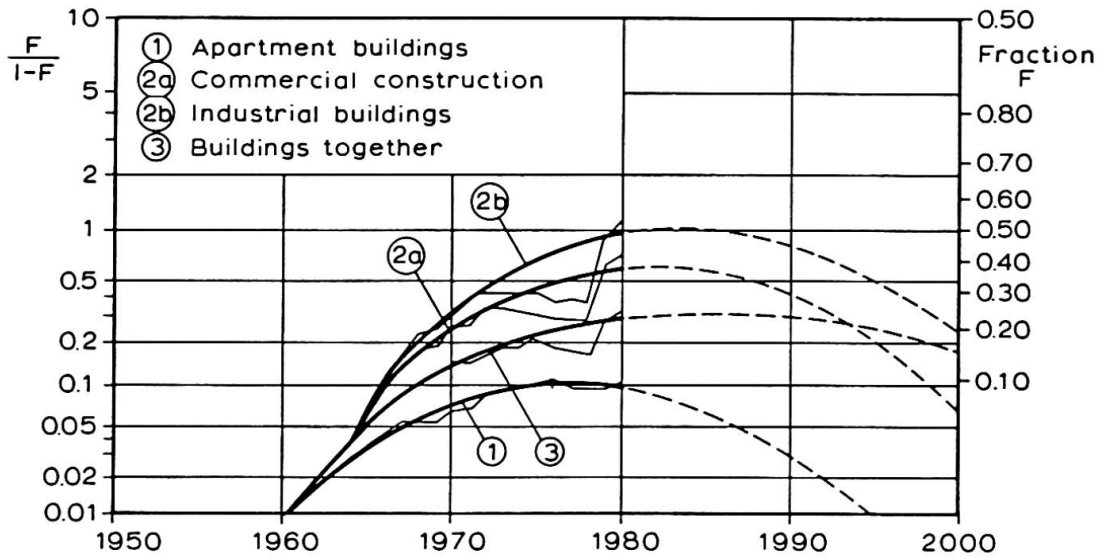

Fig. 2 Life cycle estimates of prefabricated building production in Germany, illustrated by the market fraction

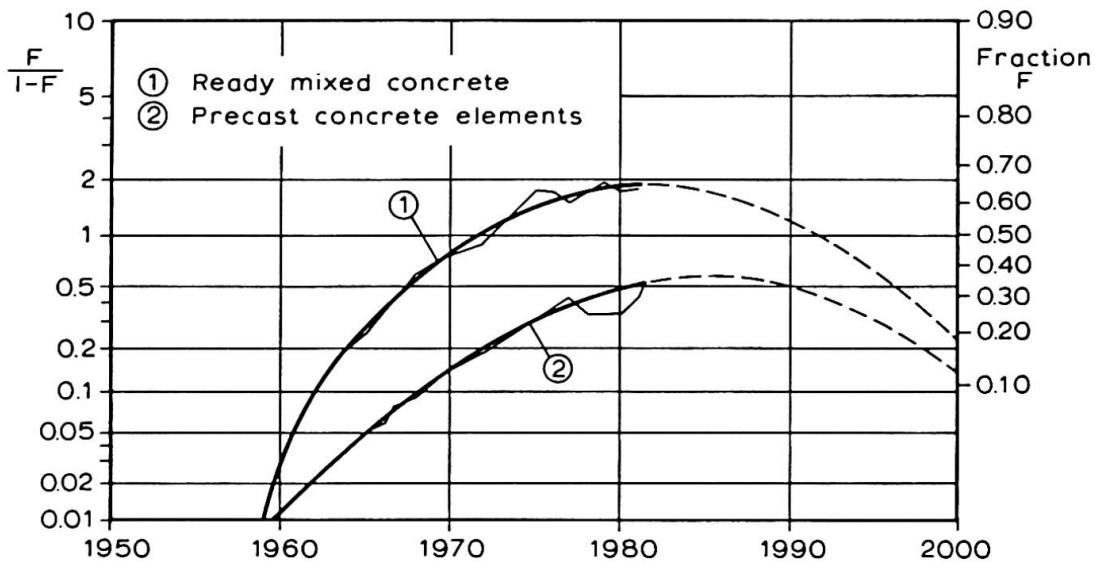

Fig. 3 Life cycle estimates of ready-mixed concrete and precast concrete production, illustrated by the fractions of total cement consumption in Finland

1.2 Conclusions drawn from the trends

On the basis of the trend estimates the following conclusions can be drawn:

- 1. The prefabrication technique can be estimated to have got a remarkable market share of the percent fraction both in Finland and in Germany between 1955 and 1960.
- 2. The modes of life cycle curves are very similar in all cases.
- 3. The evolution shows some kind of disturbance period from 1976 to 1980, corresponding to the common economical disturbance during those years. Following the local disturbance, the evolution has returned to the earlier trend.
- 4. The introductory phase of the life cycle occurred in the late 1950's and early 1960's, the early growth phase up until the mid 1970's, and the maturity phase in the late 1970's and early 1980's.
- 5. Within the next few years, it seems that life cycles will reach saturation phase and switch to a phase of more rapid decline subsequent to 1990. In the apartment building sector, the

- decline phase seems to have begun in the early 1980's.
- 6. It appears that the estimated market situation will produce a demand for new technology in the 1990's.
 - 7. Large variability in the market fraction of prefabrication over the last few years indicates a high sensitivity to changes in market conditions. The reason lies behind a weak competition ability, typical in the saturation phase of technology.

1.3 Challenges for improvement in the evolution of precast concrete technology

Principally, there are two ways in which evolutionary trends can be improved. The first possibility is that of a positive change in market conditions and the second is that of an active innovation process in precast technology.

The total size of the building construction market will in the future be either stable or even on the decrease across the whole of the developed world. The evolutionary trends in precast concrete technology indicate that these types of marked conditions are unfavourable for actual prefabrication technology. The main reasons for this are:

- the weak ability for economic competition
- the weak flexibility of prefabrication technology in adjusting to changing market requirements, such as an increase in small house construction and the development of lightweight construction techniques.

Following this conclusion, the only way to improve the future trend of evolution is the innovative development of prefabrication technology. In addition, market-orientated management and new marketing methods will naturally be needed in order to support the development of technology.

The construction markets will, in the future, also show a rise in developing countries and in some areas of energy production. The needs on these markets often differ from those in usual construction. Therefore, new technologies, as well as new orientations in marketing, must also be developed for these areas of production.

2. BASIS FOR INNOVATIONS IN PRECAST CONCRETE CONSTRUCTION TECHNOLOGY

2.1 Changes in precast concrete construction

The basic demands in construction and finalized buildings are for quality, economy, flexibility, durability, ergonomics, energy consumption and resources of raw materials.

In comparison with competing construction techniques, the precast concrete construction exhibits the basic properties presented in Table 1.

The most important potential assets not as yet put to good use are:

- the mechanization and automatization of production in the element factories and consequent savings in labour costs
- the flexibility in production, speedy erection
- the dismountability of buildings and
- the architectural properties.

Factor	Existing or potential properties
Concrete material	
-technical properties	Good statical, dynamic, resistance, durability and visual properties in common
-energy consumption	Small energy consumption
-amount of raw materials	Usually large resources, local lack may exist in some areas
-variability	Good variability of properties (strength, weight, ductility, colour)
-properties in the production process	Good processing properties
-economy	Potentially very good economy due to the simple production and low energy; the possibilities are as yet unused due to high labour consumption
-ergonomy	Some problems with noise and allergy in production
precast concrete production	Simple production techniques in comparison with most of the other building materials; potentially very good possibilities for mechanization and automatization
Erection	Potentially very speedy erection, also suitable for special conditions (cold or hot climate, offshore construction etc); also dismountable construction technique possible
Flexibility	Potentially good flexibility on the basis of flexible material properties in products as well as in the production

Table 1 Properties of basic factors in precast concrete construction

The development areas presented in Table 2 can be used in the exploitation of potential assets.

Potential asset	Demands for developments in the utilization of the potential asset
Economy and flexibility in production	Mechanization and automatization of the element factories, use of CAD/CAM (Computer-Aided Design and Manufacture) techniques in the design, manufacture and change of information
Speedy erection technique	Connection and joint techniques, computer-aided project planning and project control, development of the erection techniques, increase in the stage of prefabrication
New structural techniques	Flexible modular element systems, architectural development, dismountable construction, lightweight construction system, small house construction system. Structural components suitable for flexible use and automatized production

Table 2 Demands for technical development of precast concrete construction



3. OPEN MODULAR ELEMENT SYSTEMS

3.1 Principles for improving the economy, flexibility and quality of precast element construction

The flexible open modular element system serves as an important basis for the following scheme:

- 1.- Prefabrication is based on a limited number of national or even international open systems. The system includes common agreement of modular dimensions for each group of buildings, such as apartment houses, commercial buildings and industrial buildings.
- 2.- Each firm or group of firms produces some special type of prefabricated unit. The units are of standard types, yet still allow for individual variations in dimensions and holes within the frame of the modular system. Standard elements can be produced economically and good quality can be achieved when using industrial production methods. The designer, contractor and user can choose from among several types of element in each case, fulfilling the requirements in the best possible way.
- 3.- In order to enable the individual design of buildings, additional special units are made on an individual basis. Special units are far more expensive to produce than standard elements, but only form a small proportion of the total elements.
- 4.- Standard connections are used for the montage of the elements during erection of the building. Especially rapid montage is important. The connections also often have great influence on the quality of buildings, notably on the thermal and acoustic insulation properties and on the aesthetic properties of facades. The importance of being able to dismount the buildings is rapidly increasing.

The assets of the open system are of special importance in small market areas as well as in the international construction trade. The basic asset in small market areas is the increase in the series within production. The assets in international construction trade are improvement in design and management, and a choice between competitive offers.

3.2 The Finnish BES-system

The system is used mainly for residential buildings. The building is composed of prefabricated elements forming modular grids in all directions. The modular planes surround the modular space, the projection of which is termed modular area. The element fills its modular space, still allowing sufficient room for connections and joints. The hierarchical horizontal planning modular grids are:

- a detailed planning modular grid at block plan level primarily $n \times 3M$ ($M=100$ mm)
- a frame structure planning modular grid $A \times 12M$ ($M=100$ mm)
- a related structural component planning modular grid $n \times 3M$ ($M=100$ mm).

The structural components used in the system are transversal load bearing wall panels between the apartments, floor slabs, self-bearing or hung concrete sandwich external wall units, non-bearing internal walls and supplementary components including, for instance, balconies, staircases, WC's, saunas, kitchen components etc. An example of the modular element system in a horizontal direction is presented in Fig. 4.

The system also includes rules for standard connections and joints.

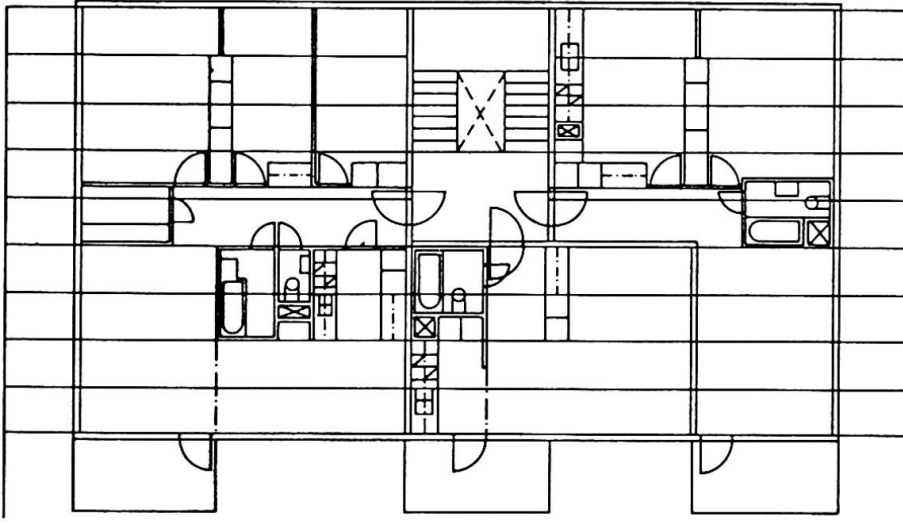

Fig. 4 Horizontal plane of the apartment building on the Finnish BES-element system

3.3 The Finnish Frame-BES system

The Frame-BES system is planned for application mainly to the construction of industrial and commercial buildings. The basic modular system is based primarily on dimensions of $n \times 6M$ ($M=100$ mm).

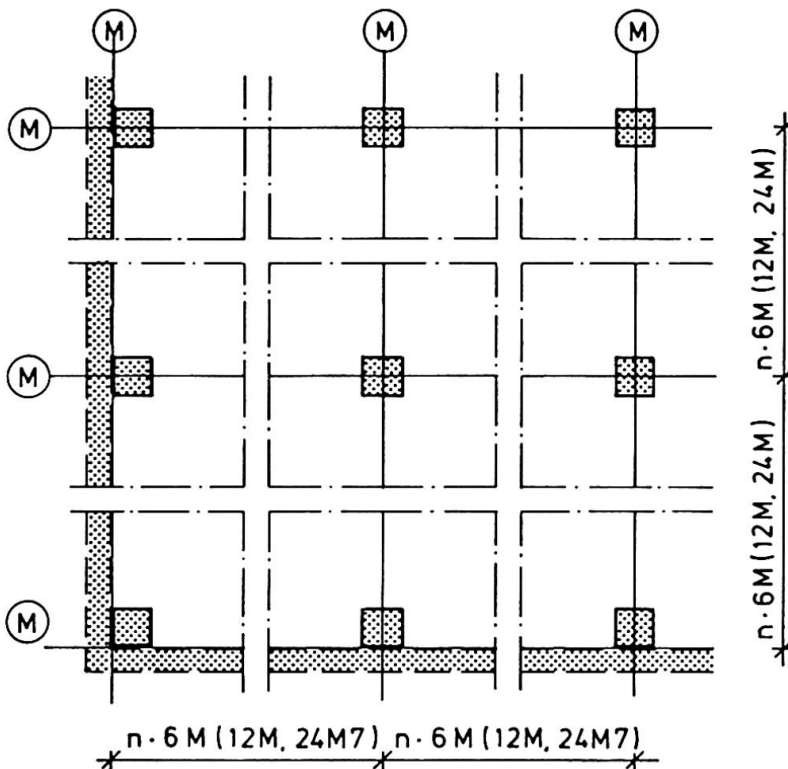

Fig. 5 The modular Frame-BES system

The structural components consist of columns, beams, TT slabs and hollow core slabs. The standard dimensions of structural components and openings as well as standard connection details are also included in the system.



REFERENCES

1. BES-Research on the development of an open system. Association of the Concrete Industry in Finland (in Finnish with English summary). 1970.
2. FRAME-BES research publications 1(Principles), 2(Design), 3(Modular dimensions), 4(Frame system), 5(Structural components), 6(Openings, fastenings), and 7(Connections). Association of the Concrete Industry in Finland (in Finnish). 1983.
3. MARCHETTI C., Die magische Entwicklungskurve. Bild der Wissenschaft 10, 1982 pp.115-128.
4. MARCHETTI C., The evolution of the energy systems and the aircraft industry. Chemical Economy & Engineering Review, May 1980, pp.7-13.
5. RUSSIG V., Schwaches Wachstum des Bauvolumens-stagnierender Anteil des Fertigteilbaus. Ausgewählte Ergebnisse der IFO-Bauvorausschätzung 1981 bis 1991. (DT) IFO Schnell-Dienst, Nr 33, 1981, s.6-16.

Thermal Behaviour of Multi-Span Viaduct in Frame

Comportement thermique d'un viaduc en portique

Thermisches Verhalten eines statisch unbestimmten Rahmentragwerkes

Ryuichiro TANAKA
Senior Struct. Eng.
Chuo Fukken Consult.
Osaka, Japan



Ryuichiro Tanaka, born in 1948, graduated from Akashi National Technical College in 1969. He is now a Certified Consulting Engineer, working as a Senior Structural Engineer in the Railway Engineering Department.

Kyosuke NATSUKAWA
Division Chief
Chuo Fukken Consult.
Osaka, Japan

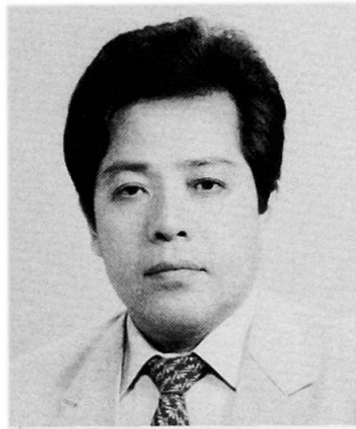

Kyosuke Natsukawa, born in 1943, got his degree of MSCE at Kanazawa University in 1968. He is now a Certified Consulting Engineer, working as a Division Chief in the Railway Engineering Department.

Takuya OHIRA
Managing Director
Nishimatsu Constr. Co.
Tokyo, Japan



Takuya Ohira, born in 1925, got his civil engineering degree in 1947. He worked for the Japanese National Railways and Japan Railway Construction Public Corporation for more than 30 years. He is now a Managing Director of Nishimatsu Construction Co.

SUMMARY

The authors designed an economical viaduct using a statically highly indeterminate frame with better moment distribution. The results of the in situ measurements on the structure over a period of one year show that the temperature expansion was successfully restrained and more material could be saved.

RESUME

Les auteurs ont réalisé, de façon économique, un viaduc en portique avec une haute hyperstaticité et une meilleure distribution du moment de flexion. Les résultats de mesures faites montrent que la dilatation causée par les changements de température est restée minime que de la matière aurait encore pu être économisée.

ZUSAMMENFASSUNG

Die Verfasser haben einen kostengünstigen Viadukt als statisch hochgradig unbestimmtes Rahmentragwerk mit einer günstigen Momentenverteilung entworfen. Die Messungen über ein Jahr haben ergeben, dass die Verformungen infolge der Temperaturschwankungen erfolgreich beschränkt werden konnten und noch mehr Materialersparnis hätte erreicht werden können.

1. INTRODUCTION

In Japan, reinforced concrete viaducts of frame are widely used for railway structures. The typical example is the viaduct for Shinkansen, the world famous bullet train line. Many concrete frame structures have been constructed because of their favorable moment distribution and lower cost.

The structures have normally expansion joints every 30-40m. To construct such structures economically, the authors designed a 400m-long viaduct based on the idea of a long continuous viaduct. See Fig. 1. and Photo 1.

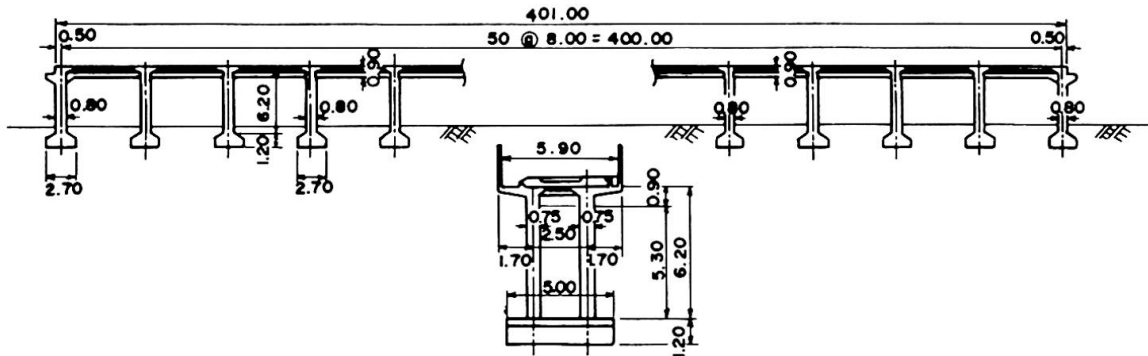

Fig. 1 General View



Photo 1. 50-span Concrete Viaduct

The basic concept of the long continuous viaduct comes from the following idea. It is well known that a long welded rail fixed on the track bed expands due to temperature change only in the end portions. Most of the expansion in the middle portion is restrained by the bed. See Fig. 2.

The application of the concept to the viaduct shows that an infinitely long viaduct could be constructed. The increased number of piers enhances the rigidity of the infrastructure, which results in the restraint of the superstructure expansion. The expansion of a viaduct longer than a certain length could be restrained to a constant value.

This paper reports on the long-term measurements of displacements and stresses of a reinforced concrete viaduct designed on the present concept and shows that the concept is applicable to the design of viaducts with possibly more economy.

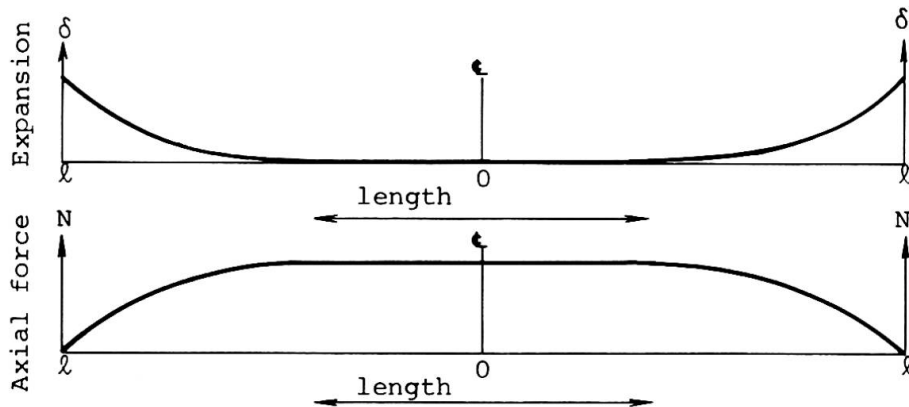

Fig. 2 Expansion, axial force and length of a long welded rail

2. DESIGN AND CONSTRUCTION

2.1 Fundamental tests

The tests of measurements necessary for the establishment of the design conditions were conducted on the following four items:

- (1) Temperature and displacement of the viaduct,
- (2) Model experiment and analysis of the designed viaduct,
- (3) Model experiment and analysis of the expansion transverse slit intervals for the expansion,
- (4) Horizontal load test applied to the foundation of an existing viaduct.

2.2 Design

The horizontal member of the viaduct is designed as a steel-reinforced concrete structure because of large horizontal forces.

The concrete strength of the columns in the end portions was made stronger by 20% to resist larger bending moment at the column ends.

The structure was analyzed elastically as a fifty-span frame taking axial deformation into account. The stress analysis was based on the allowable stress design method.

2.3 Construction

During the construction, the drying shrinkage of the concrete had to be reduced as less as possible. Using KOSAKA and MORITA'S theory, the authors estimated the amount of the shrinkage and determined that the concrete had to be placed sectionally over 3-4 spans and nine months later over the rest of the spans.

3. MEASUREMENT

3.1 Outline of measurement

The greatest difficulty in the design of the viaduct was how to deal with the large axial beam stress and column bending moment to restrain slab and beam expansion due to temperature change.

Since the main purpose of the measurement was to observe thermal behavior of the structure and identify factors preventing construction of a longer structure, the measurement was continued for one year after the construction completion and the results were studied in three periods. At the same time the crack measurement was also conducted. Table 1 shows the measured items.

Table 1 Measured Items

Surveyed items	Detail	Equipment
Weather observation	Atmospheric temperature	Thermocouple
Structural temp.	Concrete member temp.	Thermocouple
Structural displacement	Horizontal member displacement	Wire displacement meter
	Horizontal foundation displacement	Wire displacement meter
	Column displacement	Transit, plumb and cord
	Column rotation angle	Inclination meter
Stress	Reinforcement bar	Bar stress gauge
	Shape steel	Surface strain meter
	Concrete	Concrete non-stress meter
Structural soundness	Crack measurement	Crack scale
Concrete property	Compressive strength, Young's modulus	Dial gauge

3.2 Results of measurement

3.2.1 Atmospheric and member temperatures

Table 2 shows the atmospheric and structural member temperatures measured for one year. The measurement was conducted at 6:00 and 14:00. The member temperature means the average value of 12 measurements on the slabs and beams.

Some member temperatures exceeded the design limits of $\pm 10^{\circ}\text{C}$ from the average, but the measured values of stresses and expansions did not exceed the design limits, showing complicated relations between stresses, expansions and temperature change.

Table 2 Atmospheric and Member Temperature (Unit: $^{\circ}\text{C}$)

Item	Measured time		Atmospheric tem.		Member tem.	
	6:00	14:00	6:00	14:00	6:00	14:00
Max. temperature	—	30.00	—	30.00	—	30.00
Min. temperature	-1.0	—	2.0	—	—	—
Temperature difference between max. and min.	31.0		28.0			
Annual average tem.	13.3	18.9	16.3	18.0		
	16.1		17.2			
Difference between ave. and max.	13.6		12.8			
Difference between ave. and min.	17.1		15.2			

3.2.2 Relation between member temperature and expansion

Fig. 3 shows the relation between beam expansion and temperature expressed in terms of deviation from the annual average values, where the beam expansion is determined by the difference of displacements at the tops of two adjacent columns. Fig. 3a shows the relation in one of the end spans and Fig. 3b in the center span.

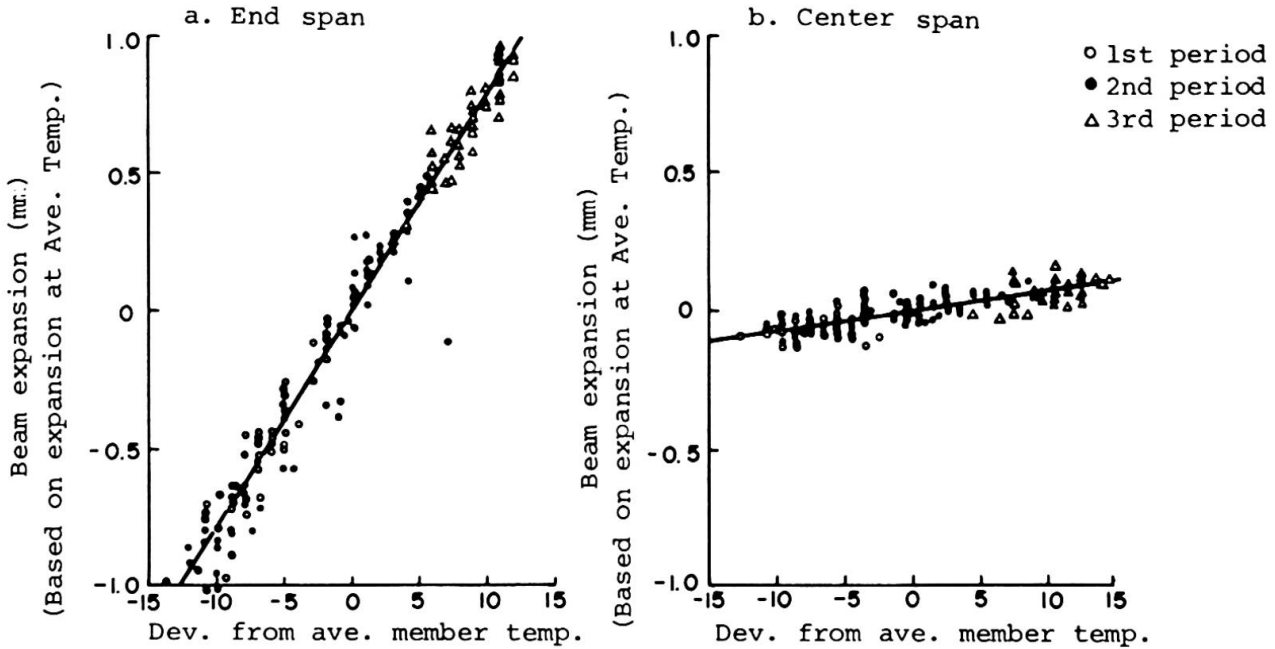

Fig. 3 Relation between beam expansion and member temperature

Fig. 3a and 3b clearly indicate the difference of expansion per unit temperature in the end span and center span, showing that the expansion in the center portion is very well restrained.

Fig. 4 illustrates the relation between the beam expansion at a temperature change of 10°C and the column position. The theoretical value based on the elastic theory is shown in the figure. The figure demonstrates accelerated restrain of the expansion towards the center of the structure. The measured values fall within the theoretical values. From the result it could be assumed that the columns in the end spans are supported elastically.

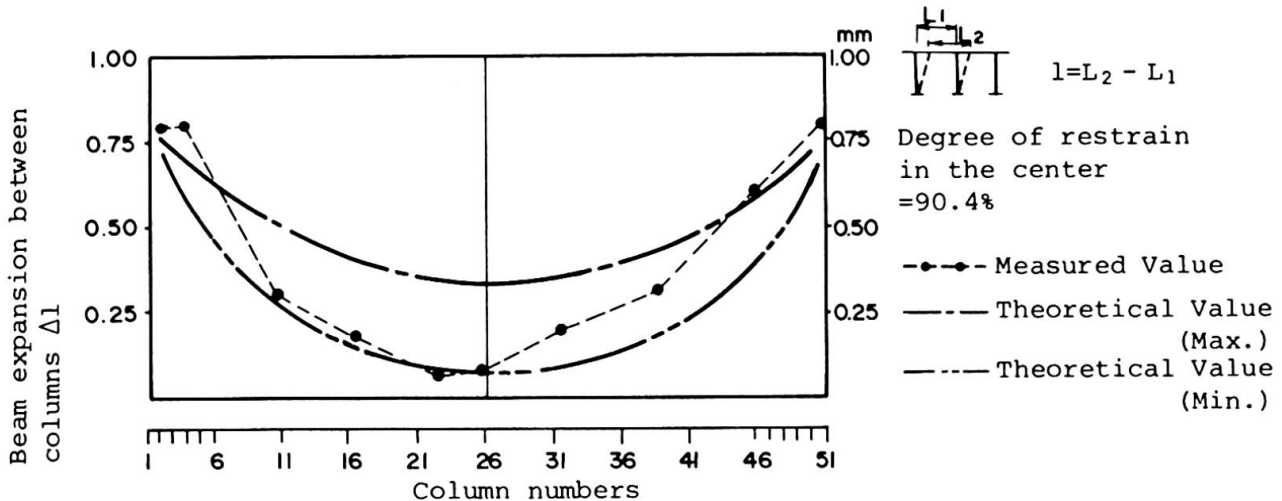

Fig. 4 Relation between beam displacement and column position (t=10°C)



3.2.3. Force and moment

The axial force and the bending moment are calculated using the measured value. Fig. 5 and 6 show the measured values and the theoretical values(2) of the axial force and the column bending moment, falling within the theoretical limits.

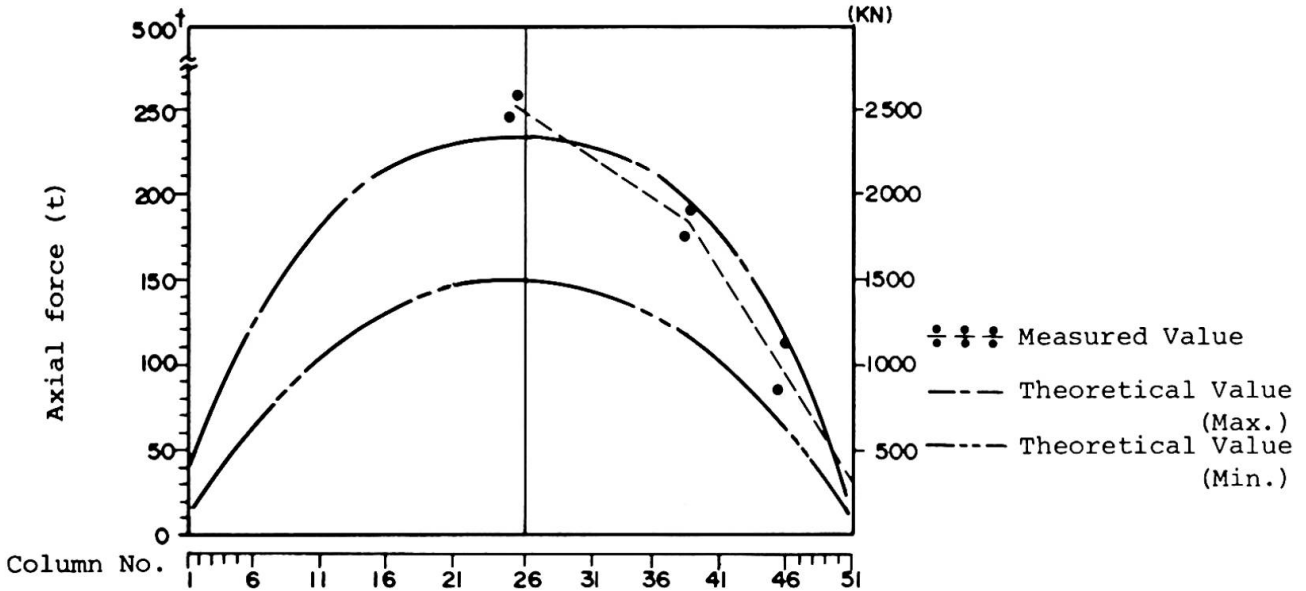

Fig. 5 Beam axial force (due to temp. difference 10°C)

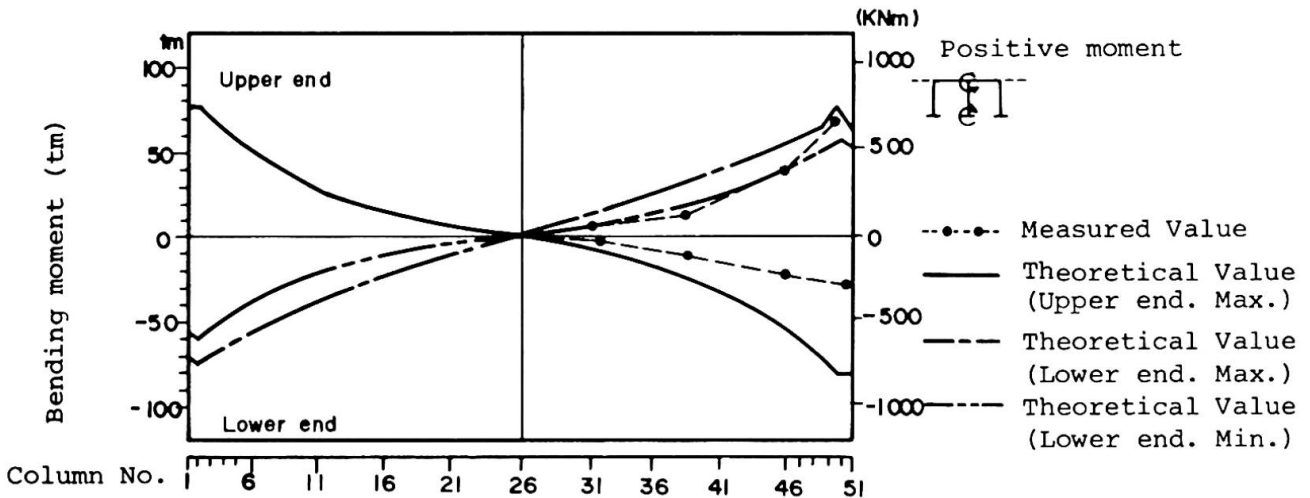

Fig. 6 Column bending moment (due to temp. difference 10°C)

3.2.4. Drying shrinkage

As explained in 2.3, concrete was partially placed nine months later. In the design, the shrinkage is assumed to finish 70% of the final value according to KOSAKA and MORITA'S theory(1) at the later concrete placement.

This assumption was verified by the stress measurement of steel bars conducted at the middle of the column height where the stress was not influenced by other factors.

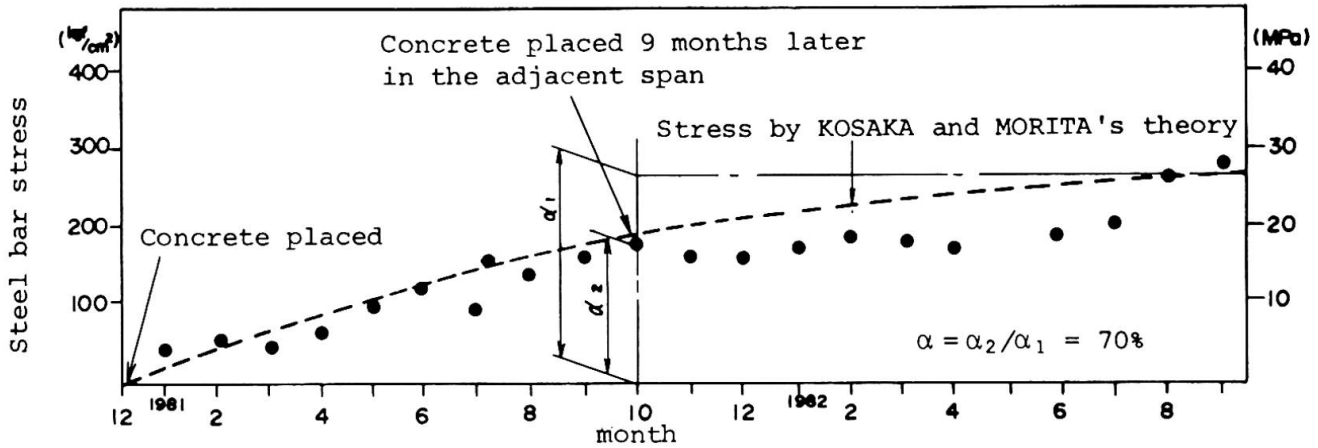

Fig. 7 Time variation of bar stress

3.2.5. Cracks

Fig. 8 shows crack development in the slabs and columns. These cracks developed mainly in winter because of the temperature shrinkage of the long and restrained structure. One year later, no further crack development was observed. More cracks developed in the center span which was restrained more strongly. The widths of the cracks were narrower than the 0.2mm cracks which were observed in the ordinary concrete viaduct and showed better durability of the structure.

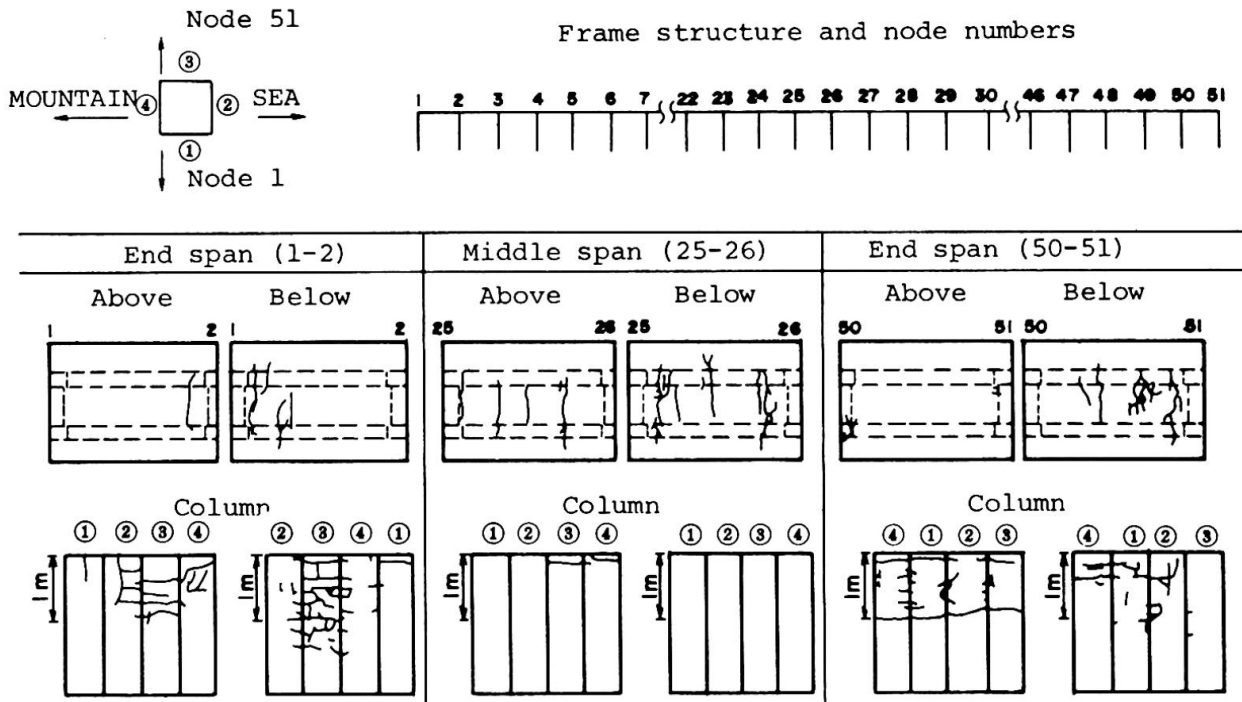

Fig. 8 Cracks in slabs and columns

4. SUMMARY OF THE MEASUREMENT

The results can be summarized as follows.

- (1) An application of the long welded rail concept

The temperature expansion of the 400m-long viaduct was restrained as much as 90.4% in the center span. This result shows that the concept of the

long welded rail can be applied effectively to the design of a long multi-span viaduct in frame.

(2) Concrete placement for the reduction of drying shrinkage

Concrete placement executed nine months later in every fourth or fifth span was successful for the reduction of the drying shrinkage. For the estimation of the drying shrinkage, KOSAKA and MORITA'S theory(1) is useful.

(3) Column support condition

The measurement shows that the columns are virtually supported by horizontal and rotational springs at the lower ends. The coefficients of the rotational and horizontal reactions estimated from the measurement agree with the results of a load test at the construction site.

(4) Material saving

The calculation based on the measurement shows that the reinforcement in some sections could be saved as much as 20%.

5. ACKNOWLEDGEMENT

The authors are grateful to Japan Railway Construction Public Corporation, the Superintendent of the project, for allowing them to publicize the data.

REFERENCES

- 1 Y. KOSAKA, and S. MORITA, Reinforced Concrete Structure. Maruzen, 1975, p.79 (in Japanese).
- 2 Study Committee of Structural Design Method in Special Environment, Report on the Study of Multi-span Viaduct. Kinki Branch of Japan Construction Consultants Association, 1982, p. 52 (in Japanese).



Three Short-Span Concrete Bridges in Greater Vancouver

Trois ponts en béton, de courtes travées dans le Grand Vancouver

Drei Beton-Brücken mit kurzen Spannweiten in Greater Vancouver

David I. HARVEY
Senior Struct. Eng.
Associated Eng. Services
Burnaby, BC, Canada



Born in 1947, David Harvey obtained his Bachelor's and Master's degrees in engineering at the University of Bristol, UK. Following thirteen years of experience with concrete bridges in the UK, he joined AESL in 1982. His special interests are the development of innovative design concepts and the aesthetics of bridges.

SUMMARY

Significant constraints upon construction activities can exert a profound influence upon the economics of various bridge design alternatives and their methods of construction. In many instances, unusual or innovative techniques are appropriate. Three examples of current projects where site constraints played a predominant role in the design and execution of short-span concrete bridges are presented. The particular requirements of each site dictated a novel design approach, unusual construction operation, or the adaptation of standard techniques for special purposes.

RESUME

Des contraintes importantes sur des activités de construction peuvent influencer énormément le coût des variantes d'un projet et leur méthode de construction. Dans bien des cas des techniques nouvelles ou exceptionnelles sont appropriées. Trois exemples de réalisations illustrent le rôle prédominant de contraintes locales sur le projet et la réalisation de ponts courts en béton armé. Les conditions particulières de chaque chantier ont conduit à une nouvelle variante de projet, à une phase inhabituelle de construction, ou à une adaptation de techniques conventionnelles à des besoins particuliers. Les conditions nécessaires de chaque endroit a conduit à une approche unique dans le projet, les méthodes spéciales ou l'adaptation de méthodes traditionnelles pour l'utilisation spéciale.

ZUSAMMENFASSUNG

Beträchtliche Einschränkungen in der Bautätigkeit können in der Planung und der Bauausführung entscheidende Einflüsse auf die Kosten von Brückenkonstruktionen ausüben. In vielen Fällen müssen ungewöhnliche und neue Bauweisen in Betracht gezogen werden. Drei Beispiele gegenwärtiger Projekte von Betonbrücken mit kurzen Spannweiten, bei denen Einschränkungen an der Baustelle eine bedeutende Rolle im Entwurf und der Bauausführung spielten, sind hier dargestellt. Die besonderen Anforderungen der verschiedenen Baustellen forderten eine neue und fortschrittliche Entwurfsplanung, ungewöhnliche Bauweisen, oder eine Anpassung der konventionellen Bautechnik für spezielle Fälle.

1. INTRODUCTION

Three examples of short-span bridges, recently completed, or currently under construction in the Greater Vancouver area of British Columbia, Canada, have demonstrated the influence that site constraints have exerted upon the methods adopted for their construction. In each case the particular site constraints limited either the bridge design or the construction techniques to a narrow range of options, although the price tendered for each structure suggests that this did not result in any financial penalty; all three tender prices were at or below normal construction rates for bridges of this size.

Despite the markedly differing nature of the sites, each example demonstrates the close relationship between design and construction in bridgeworks. The unique nature of each bridging requirement demanded novel solutions, yet in no case has this resulted in undue difficulties. It is believed that the bridges described herein illustrate how designs can be developed using standard construction techniques, albeit in an unusual way, without any sacrifice in the economy, durability, and elegance prevalent in successful bridges.

2. LANGLEY BYPASS BRIDGE

2.1 Background

Scheduled for construction in mid-1984, the new bypass bridge will carry the Langley bypass over the Nicomekl River, in Langley, B.C. The bridge, shown in Figure 1, is 35 m long by 24 m wide, and carries the four-lane highway, a left-turn lane, median and sidewalks. The bridge is intended as a replacement for the load-restricted 208th Street bridge.

Unlike the nearby 208th Street Bridge, which is submerged frequently by floodwater, the bypass is located on embankment across the Nicomekl's flood plain. To minimize the restriction on the passage of floodwater at the new bridge site, the deck soffit is located above the estimated 1 in 200-year flood. Only 850 mm above this elevation was available for construction depth, as the new bypass profile has to intersect with the Fraser Highway, close by the north end of the bridge. A two-span structure, supported by abutments and a central pier, was possible but construction would have had a major impact on the river. Additionally, the weak nature of the subsurface deposits caused problems with aseismic design of the substructure; the high lateral loads resulted in an uneconomical number of piles, thus the scheme proved to be more costly than the design selected.

Elimination of the abutments and the introduction of a pier on each side of the river resulted in a central span of 22 m and two 6.5-m long cantilever side-spans. Shorter than a central support, these piers share the seismic loads and experience minimal earth-pressure. The deck extremities abut the road embankments and carry the articulated approach-slabs, which effect the transition from earthfill to structural support. The deck comprises twin post-tensioned concrete slabs which are voided over the central span, linked by a transverse-spanning deck slab and provided with edge cantilevers.

The piers each comprise seven 600-mm diameter columns on a common pilecap supported by 54 timber friction-piles, all battered at 3:1. This arrangement permitted ductile-frame aseismic design of the bridge; with a check to ensure adequacy of the piles at maximum ultimate column-strength. The finalized pile arrangement was particularly efficient, with a maximum pile load of 285 kN. Battered piles were necessary because of the very poor subsurface conditions, which were incapable of adequately supporting vertical piles; the upper eight metres of subgrade being subject to liquefaction during earthquakes.

2.2 Construction

Before construction began, the Nicomekl River paralleled the south shoulder of the Fraser Highway. During 1983 the bypass embankment was built, and the river channel relocated some 20 m further south. The river diversion was required to accommodate the new highway intersection and to keep the bypass bridge clear of the associated turning radii. The approach embankments were built in advance of bridge construction to consolidate the soft underlying alluvial-deposits. It is estimated that precompression of the subgrade will minimize differential settlement between the bridge and the embankments, and preserve the riding quality of the finished pavement.

In 1984 the first operation will be to carry out the advance pile-test, followed by installation of the permanent piles, along with construction of pilecaps and columns. The cast-in-place, post-tensioned concrete deck cannot be built until the June-through-September period available for construction activities in the river. Because of the weak subgrade, the use of pile-supported falsework was specified. The post-tensioned decks will be constructed sequentially, permitting reuse of the falsework. The deck-slab linking the post-tensioned superstructures will be built from suspended formwork. Addition of the approach-slabs, parapet railing, waterproof membrane and asphalt will complete the bridge. Unusually for a bridge of this size, the concept does not require the installation of either bearings or deck expansion-joints.

2.3 Discussion

Site constraints led to the construction of an unusual structure. The use of cantilevered end-spans is believed to be an innovative concept, eliminating the problems of high seismic-induced loading on bridge abutments. The avoidance of costly, piled abutments yielded significant savings. Despite the necessity of using temporary piles for falsework support, the construction of a cast-in-place concrete structure in very poor ground-conditions proved to be a practical, economical solution. The result will be an elegant bridge which nicely complements its attractive environment.

The use of conventional construction techniques applied to an unconventional structure assisted in minimizing the construction cost. The tender price, very low for a piled bridge, was \$540,500, or approximately \$643 per square metre. Completion is scheduled for September 1984.

3. KINGSWAY BRIDGE

3.1 Background

Until early 1984, Kingsway Avenue crossed the Coquitlam River via an aging, substandard steel-truss bridge with steeply-ramped approaches. Carrying a major arterial road connecting Port Coquitlam, B.C., with the remainder of the Greater Vancouver area, the single-lane bridge was inadequate for current traffic. A replacement concrete-bridge is scheduled for construction during the summer of 1984 (Fig. 2). 10.8-m wide by 61-m long, it carries two traffic lanes and a sidewalk over the river, and has approach ramps improved to urban-arterial standard.

The site is extremely confined. Immediately north of the bridge site is the Canadian Pacific Railway right-of-way and the CPR river crossing, also a 61-m span steel-truss bridge. About 15 m separates the two structures, this land being used by utility companies for overhead cables. To the south, a block of elderly commercial properties were located immediately adjacent to the existing sidewalk. The road alignment dictated that the new bridge must be at the same

the same location. Part of the CPR right-of-way was available for construction working space, and by acquiring the commercial properties, it was possible to arrange a temporary diversion of Kingsway to the south of the bridge site. A preliminary study indicated that the most economical method of providing temporary bridging of the river was to relocate the steel-truss onto temporary abutments during a road closure, a method offered to and the one selected by the contractor.

Inspection revealed that the existing concrete abutments on timber piles were in good condition, and with new cap-beams and wingwalls were capable of supporting the end reactions of the new bridge. To avoid excessive length of approach ramps, the new bridge has a slender profile; a double row of columns in the middle divides the structure into two main spans. For economy, and to simplify falsework, these consist of standard precast, pretensioned concrete girders, continuous with cast-in place concrete beams over the central section. A 200-mm thick concrete deck-slab connects the four girders transversely.

Two alternative foundation systems were offered to tenderers. The first consisted of sixteen 350-mm diameter steel pipe-piles, raked at 1:3, together with two pile caps and grade beams below the river bed. The second comprised eight 900-mm diameter steel pipe-piles, each vertically below a column and without pile caps or grade beams. All tenders selected the latter system. Both foundation systems utilize the eight 600-mm diameter concrete columns as a ductile frame in resisting seismic loads. Whereas the battered piles were designed as end-bearing axially-loaded members, the vertical piles resisted seismic loads by lateral bearing on the subsurface sand and gravel deposits.

3.2 Construction

The first operation which the contractor has to undertake is to construct the temporary traffic-diversion. This will entail moving the steel-truss bridge some twelve metres downstream, lowering it onto temporary crib-abutments and building road approaches. This will be effected using guide rails and sliding shoes at each end of the bridge, which will be moved laterally and lowered using jacks. This is expected to be accomplished during a weekend road-closure.

The next phase will consist of abutment modifications, and driving of the steel pipe-piles. The manoeuvring space required for the large piling-rig will determine the location of the temporary traffic-diversion. In order to splice the precast girders with the cast-in-place concrete superstructure-beams, temporary support-frames will be required for the interior ends of the girders. Once the beams are cast and the concrete has gained sufficient strength, all falsework can be removed and the remainder of construction work can take place outside the high-water wetted perimeter of the Coquitlam river. Deck construction can proceed using support from the superstructure beams and girders. Installation of expansion joints, parapet railing, waterproof membrane and asphalt will complete the bridge. The final operation will consist of removal of the temporary diversion and disposal of the steel-truss bridge.

3.3 Discussion

Constricted working space characterizes the Kingsway bridge site. The necessity of placing the new bridge at the same location as the old resulted in reuse of the existing abutments, suitably modified for their new role. The problem of maintaining traffic flow during construction was dealt with by sliding the steel truss laterally, an expedient and inexpensive solution, rarely undertaken. Despite the confined nature of the site, efficient structural-design combined with appropriate construction-techniques resulted in an economical bridge. Of a total project tender-price of \$797,000, the bridge replacement was priced at \$530,000 or \$805 per square metre. The bridge is due to be completed in September 1984.

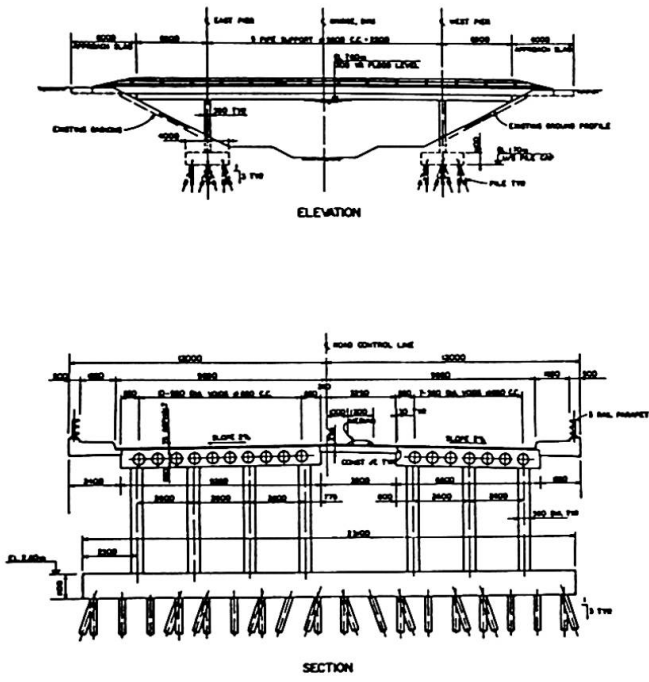

FIGURE 1/LANGLEY BYPASS BRIDGE

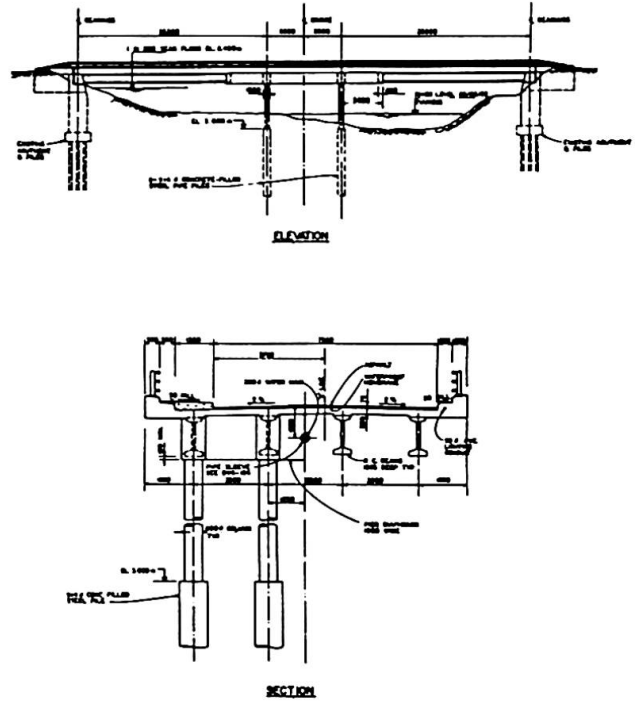
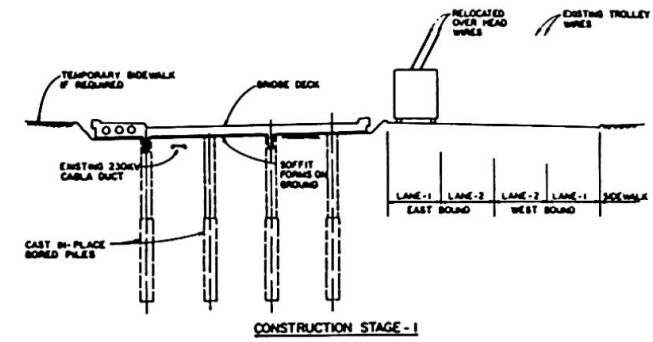
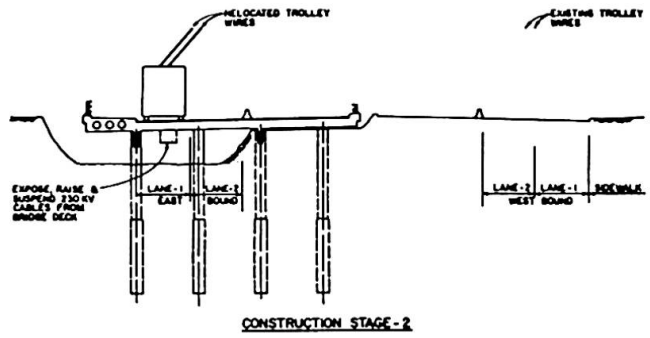

FIGURE 2/KINGSWAY BRIDGE



CONSTRUCTION STAGE-1



CONSTRUCTION STAGE-2

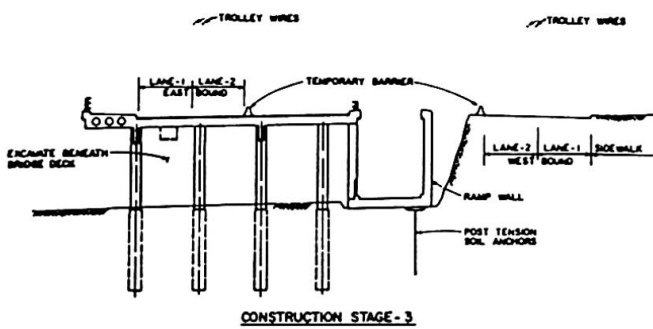

CONSTRUCTION STAGE-3

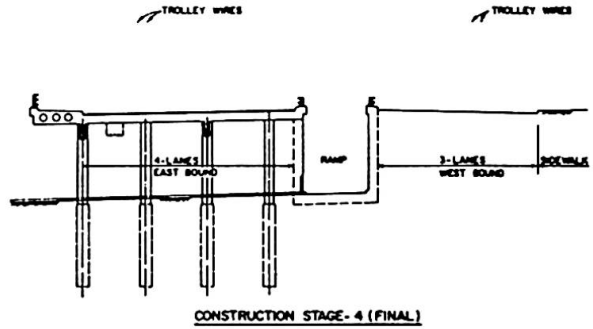

CONSTRUCTION STAGE-4 (FINAL)

FIGURE 3/OAKRIDGE CENTRE 41ST AVENUE BRIDGE-CONSTRUCTION STAGES



4. 41st AVENUE BRIDGE

4.1 Background

As part of the Oakridge shopping-mall redevelopment, a grade-separated exit from the car park was required beneath 41st Avenue, a major traffic route in Vancouver, B.C. The city stipulated that four lanes of traffic, including electric-bus service, be maintained throughout construction. The exit route was to pass beneath a new bridge, 17-m wide by 30-m long, carrying four lanes of eastbound traffic and a sidewalk, to emerge in retained cutting in the median. A ramp was to be provided to enable shopping-centre traffic to merge with westbound traffic on 41st Avenue. Because of construction work in the shopping centre, traffic flow had to be maintained within the boulevard limits. A complication was the presence of three sensitive, 230-kV underground electric-power cables. Relocation of these was prohibitively expensive and thus the bridge had to be built around them.

Because of the close proximity of traffic, deep excavation for bridge foundations would have proved costly. Accordingly, a system was developed which involved only shallow excavation at the bridge abutments; intermediate foundations were formed using bored piles, socketed into the underlying glacial-till. The bridge selected, a three-span continuous concrete-slab, utilized discrete-column intermediate supports, formed within the pile shafts, which were located to avoid the 230-kV and 22-kV underground cables. The bridge deck was to be built in shallow excavation, and could be used to carry eastbound traffic when complete. The 230-kV cables were to be enclosed and suspended beneath the bridge deck, whereas the 22kV-cables were to be diverted through ducts cast into the concrete superstructure.

4.2 Construction

Commencing in mid-1983, the first stage of construction was to temporarily provide four traffic-lanes to the north of the bridge using the three westbound-lanes along with the median (Fig.3). Electric-bus operations were maintained by deflecting the overhead wires. With the bridge site clear of traffic, piling work started. Eight 750-mm diameter bores were sunk ten metres into the till. A five-metre long, 600-mm diameter column-form was suspended in each bore, aligned and plumbed. With the reinforcing cages in position, the piles were concreted, and the annuli filled with sand.

The bank-seat abutments and deck downstand-walls were built around the electric cables in shallow excavation, then backfilled. Excavation for the deck slab involved working within 1.5 metres of traffic. Deck formwork was bedded on the bottom of the excavation. After fixing inserts for suspended services, reinforcement and ductwork were placed, and the deck was concreted. Waterproofing, deck asphalt, and parapet railing were installed, and the two eastbound traffic-lanes diverted over the bridge. At this point, the overhead wires for electric buses were repositioned in their final location.

The second construction stage involved excavation beneath the bridge deck. This work commenced from the south, working towards the median. As the deck formwork was undermined it was removed. Carefully exposing the 230-kV cables, the utility company suspended them from the bridge deck. Excavation for the exit ramp followed, along with removal of the column forms.

The third stage involved construction of retaining walls for the exit ramp. With only 2.5 metres between the north wall and westbound traffic, the excavation face was supported with rock-bolts and shotcrete. Generally the walls are U-shaped with the ramp traffic running directly on top of the footing. However, to the north of the bridge deck, the ramp wall becomes L-shaped and overturning must be considered. The solution was the installation of a row of ten 90-tonne

ground anchors, drilled vertically through openings in the footing, some fifteen metres into the till. Inclined anchors could not be used as no part of the permanent works was permitted beyond the north edge of the median. Construction work was completed by the laying of asphalt, the installation of parapet railing, and the placing of rubble slope-paving beneath the bridge.

4.3 Discussion

The structural system adopted was influenced mainly by the need to avoid traffic disruption along this busy route. Additional factors were the presence of sensitive underground services together with the need to provide an attractive, economical grade-separated exit from the shopping centre. To this end, the 3.6-metre wide ramp was widened to 6.0 metres beneath the bridge, and the bridge supports skewed differentially, at 25° and 40°, to accommodate the curve beneath the bridge without excessive over-spanning. The resulting exit route is provided with a generous turning radius, good visibility and the maximum of natural lighting. Visual amenity is improved by attention to detail: the retaining walls feature a pleasant, vertical-ribbed finish; the rubble slope-paving provides an attractive, rough texture; and the slender parapet railing affords the maximum of natural lighting. Of a total price of \$812,000 for the underpass, approximately \$500,000 or \$980 per square metre related to the bridge, which was completed early in 1984.

5.0 CONCLUSIONS

In today's economic climate, it is imperative to obtain value from investment in in public-works projects. The examples described illustrate how economy was achieved in bridge construction by careful evaluation of site constraints at conceptual-design stage. Of vital importance is to perceive the construction methods implicit in the design. Ingenuity in the application of construction techniques can yield substantial savings in the cost of bridgeworks at constrained sites.

ACKNOWLEDGEMENTS

The author wishes to acknowledge the contribution made to the projects described by the following parties:

Langley Bypass Bridge:	Owner:	City of Langley
	Contractor:	Miller Construction
Kingsway Bridge:	Owner:	City of Port Coquitlam
	Contractor:	MDM Construction
41st Avenue Bridge:	Owner:	Woodward's Stores
	Architect:	Armour Blewett & Partners
	Contractor:	PCL Construction

The contributions made by many other agencies and individuals in the execution of the works and preparation of this paper are gratefully acknowledged. Opinions expressed are entirely those of the author.

Leere Seite
Blank page
Page vide



**Conclusions to Seminar XI
Developments in the Construction of Reinforced and Prestressed Concrete Structures**

Renaud FAVRE

Professor
Swiss Fed. Inst. of Technology
Lausanne, Switzerland

Six papers were presented orally at this session by Messrs. L. Fan, China; V. Acanski, Yugoslavia; M. Goto (instead of E. Nakashima), Japan; J. Hejnic, Czechoslovakia; A. Sarja, Finland; R. Tanaka, Japan.

This session gave some interesting examples of newly executed structures, but unfortunately it did not allow any conclusions to be drawn concerning future trends.

How dilatations of a bridge can be reduced by thick columns with fixed ends was shown by an example of a railway bridge in Japan.

The other contributions show the great diversity in the construction techniques of concrete structures. Thus the development of several big cantilever and cable-stayed bridges in China, the erection techniques with prefabricated box girders, monolithically assembled to a two-level bridge were presented, also the use of flowing concrete for an arch bridge and the development of prefabrication in Finland.

It is clear that this theme merits further consideration in a future congress.

Leere Seite
Blank page
Page vide