

# Theme IVc: Foundation structures for long span bridges

Objektyp: **Group**

Zeitschrift: **IABSE congress report = Rapport du congrès AIPC = IVBH  
Kongressbericht**

Band (Jahr): **10 (1976)**

PDF erstellt am: **20.09.2024**

## **Nutzungsbedingungen**

Die ETH-Bibliothek ist Anbieterin der digitalisierten Zeitschriften. Sie besitzt keine Urheberrechte an den Inhalten der Zeitschriften. Die Rechte liegen in der Regel bei den Herausgebern.

Die auf der Plattform e-periodica veröffentlichten Dokumente stehen für nicht-kommerzielle Zwecke in Lehre und Forschung sowie für die private Nutzung frei zur Verfügung. Einzelne Dateien oder Ausdrucke aus diesem Angebot können zusammen mit diesen Nutzungsbedingungen und den korrekten Herkunftsbezeichnungen weitergegeben werden.

Das Veröffentlichen von Bildern in Print- und Online-Publikationen ist nur mit vorheriger Genehmigung der Rechteinhaber erlaubt. Die systematische Speicherung von Teilen des elektronischen Angebots auf anderen Servern bedarf ebenfalls des schriftlichen Einverständnisses der Rechteinhaber.

## **Haftungsausschluss**

Alle Angaben erfolgen ohne Gewähr für Vollständigkeit oder Richtigkeit. Es wird keine Haftung übernommen für Schäden durch die Verwendung von Informationen aus diesem Online-Angebot oder durch das Fehlen von Informationen. Dies gilt auch für Inhalte Dritter, die über dieses Angebot zugänglich sind.

**IVc**

**Structures des fondations pour les ponts de  
grande portée**

**Foundationen für weitgespannte Brücken**

**Foundation Structures for long span Bridges**

Leere Seite  
Blank page  
Page vide

## Les fondations profondes des pylônes du pont de Brotonne

Tiefgründung der Pylonen der Brotonnebrücke

The Deep Foundations of the Towers of the Brotonne Bridge

J.L. BRAULT  
 Professeur ENPC  
 Ingénieur D.D.E., Seine Maritime  
 Rouen, France

J. MATHIVAT  
 Professeur ENTP, Directeur des Etudes  
 Entreprises Campenon Bernard  
 Paris, France

Les fondations profondes des ponts de grande portée sont constituées généralement, soit de caissons, havés à l'air libre ou foncés à l'air comprimé, soit de pieux forés de diamètre égal ou supérieur à 2 m.

Si les appuis des ouvrages sont implantés en site terrestre, ou s'ils sont situés en site nautique, mais peuvent être reliés provisoirement à la rive par un remblai d'accès ou une digue, un autre type de fondation peut être envisagé. Il s'agit de colonnes cylindriques, de grandes dimensions, exécutées à l'abri d'un cuvelage autostable réalisé au moyen d'une paroi moulée.

Cette solution présente plusieurs avantages :

- la fondation est massive et offre une excellente résistance vis-à-vis des chocs accidentels : corps flottants et convois fluviaux;
- sa structure est simple de conception et économique d'exécution; les bétons de fondation sont mis en oeuvre dans des conditions de fiabilité supérieures à celles des pieux;
- si le substratum est étanche, ou peut le devenir par un traitement approprié (tel des injections), elle permet une reconnaissance visuelle et une investigation géotechnique du terrain d'assise, pouvant conduire éventuellement à un ajustement du niveau de fondation.

L'objet de la présente communication est de décrire une solution de ce type qui a été retenue pour les fondations des pylônes du pont de Brotonne et d'analyser les enseignements qui peuvent être tirés de cette expérience.

### 1- Description des fondations du pont de Brotonne

Le pont de Brotonne, qui assurera le franchissement de la Seine entre Rouen et Tancarville, comprend dans sa partie centrale un pont à haubans en béton précontraint de 320 m. de portée qui constituera pour l'instant le record du monde des ouvrages de cette catégorie (fig. 1).

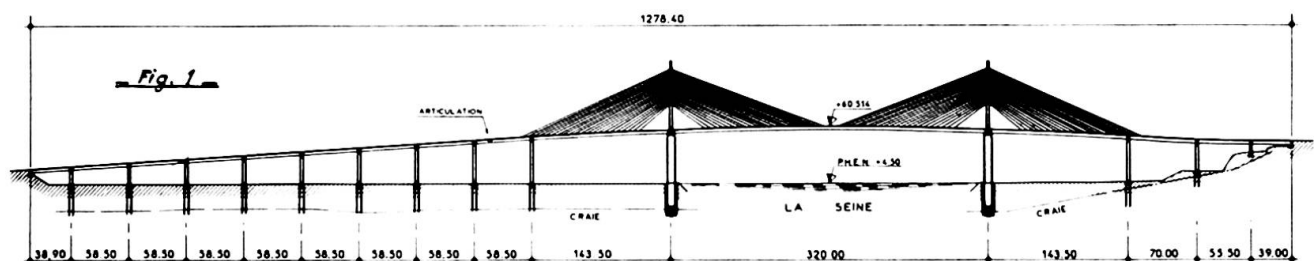

Son tablier est encastré élastiquement sur les pylônes par l'intermédiaire d'une couronne d'appui en néoprène fretté et sa suspension se compose de haubans multiples répartis disposés en éventail dans le plan médian de la structure.

Les pylônes sont fondés sur des colonnes cylindriques, partiellement évidées, de 35 m de profondeur. Ces colonnes ont été exécutées en coffrage glissant à l'intérieur d'une enceinte circulaire en paroi moulée, de 12,5 m de diamètre extérieur et de 0,80 m d'épaisseur, descendue jusqu'au substratum. L'enceinte, servant de batardeau, a été excavée, puis épuisée, les terrassements étant poursuivis à sec dans la roche saine en dessous de la paroi moulée sur environ 4 m (fig. 2).

Le projet de cet ouvrage, en particulier la conception des fondations des pylônes, a fait l'objet d'une variante, étudiée et proposée par l'Entreprise Campenon Bernard et retenue après appel d'offres par la Direction Départementale de l'Équipement de la Seine Maritime.

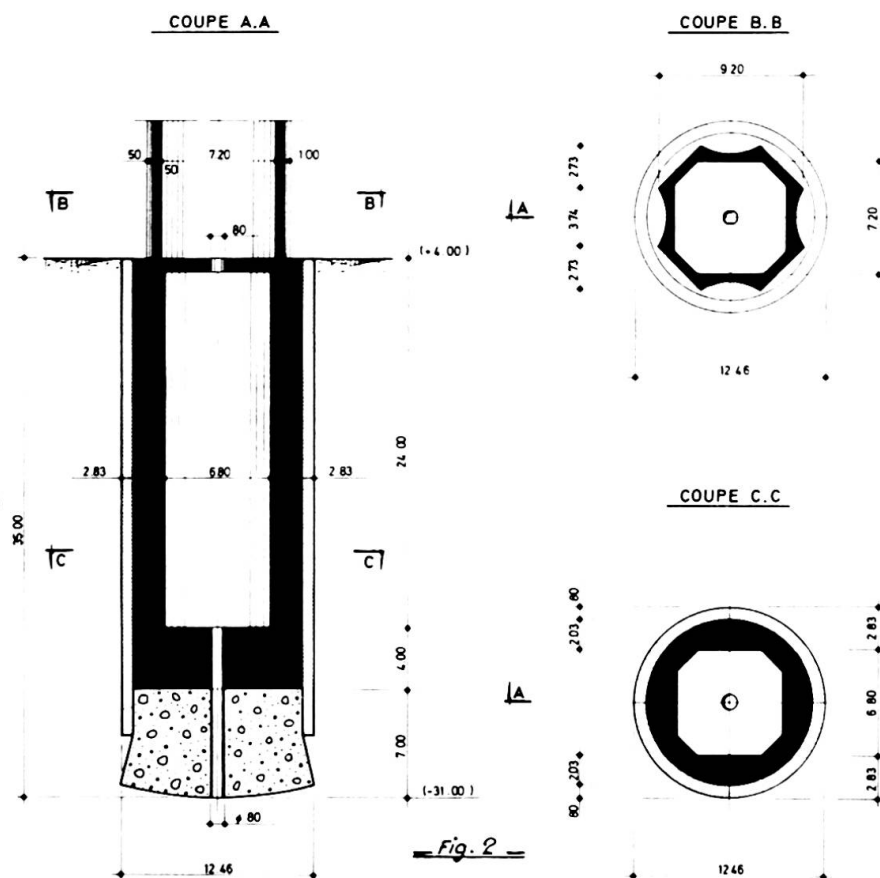

## 2- Reconnaissance géotechnique - Nature et caractéristiques des terrains de fondation

Les reconnaissances géotechniques, tant préalables qu'in situ, ont revêtu un caractère très poussé.

Lors de l'établissement du dossier d'appel d'offres, il a été effectué à l'emplacement de chacun des pylônes, implantés en bord de Seine :

- 4 sondages verticaux dont :

- 2 forages carottés, en 116 mm de diamètre, avec essais de laboratoire sur les échantillons intacts prélevés;
- 2 forages, en 64 mm de diamètre avec essais pressiométriques;

- 1 forage incliné à 30° sur la verticale et orienté vers le lit de la Seine, en 66 mm de diamètre.

Les quatre premiers forages ont atteint une profondeur de 50 m, le dernier étant arrêté 10 m plus haut.

Avant l'exécution des travaux, on a procédé à trois sondages complémentaires, disposés suivant un triangle équilatéral et complétés par des essais d'eau (essais Lugeon) destinés à évaluer la perméabilité du substratum.

Enfin, à partir du fond de fouille, trois essais pressiométriques de contrôle, réalisés sur 4 m de profondeur, ont confirmé les résultats de la campagne de reconnaissance initiale.

Au droit des fondations, les terrains rencontrés étaient les suivants :

de + 4 à - 13 : remblais, alluvions et limons;  
de - 13 à - 23 : alluvions sablo-graveleuses;  
à partir de - 23 : craie, d'abord altérée, puis de plus en plus consistante.

La cote de fondation théorique a été fixée dans la craie saine à - 31, c'est-à-dire à une profondeur de 35 m.

Les essais de laboratoire ont montré que la résistance à la compression simple de la craie saine était comprise entre 20 et 80 bars et sa résistance à la traction entre 5 et 10 bars, ce qui correspond à des caractéristiques mécaniques élevées :

angle de frottement interne  $\varphi \geq 20^\circ$   
cohésion  $C \geq 5$  bars

La valeur minimale de la pression limite nette déduite des essais pressiométriques était égale à 45 bars.

L'altération de la craie se manifestait en profondeur par une fissuration de la roche, dont la forte perméabilité a été mise en évidence par les essais d'eau. Cette perméabilité a pu être réduite suffisamment pour permettre l'exécution à sec de la fondation, grâce à des injections au coulis de ciment comportant un rideau d'encagement extérieur prolongeant le cuvelage en paroi moulée et un fond étanche.

### 3- Stabilité et portance de la fondation

#### 3,1- Stabilité de la fondation

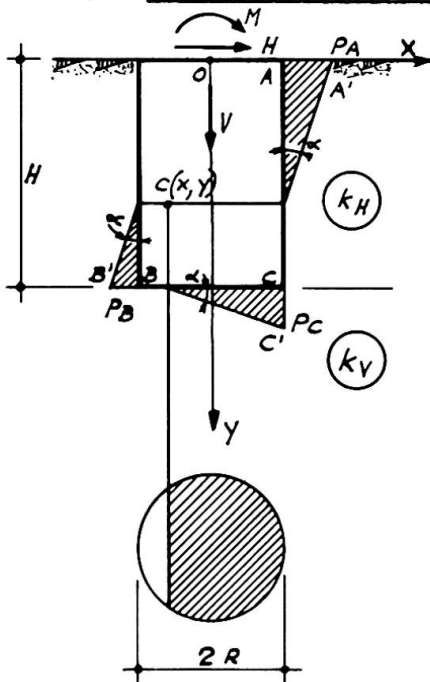

— Fig: 3 —

Compte tenu de ses dimensions (diamètre 12,5 m - hauteur 35 m), la colonne de fondation peut être considérée comme un massif cylindrique indéformable encastré dans le terrain. Ce massif est défini par son rayon R et sa hauteur H d'encastrement (fig. 3).

Sous l'effet des efforts appliqués, comprenant un effort vertical V, somme de la réaction exercée par la superstructure et du poids propre du massif, un effort horizontal H et un moment de renversement M agissant en tête, le massif va tourner d'un angle  $\alpha$  autour d'un centre instantané de rotation C.

On peut admettre que l'amplitude de cette déformation est suffisamment faible pour que le sol travaille dans la phase des déformations pseudo-élastiques. Les pressions exercées sur le sol seront alors supposées normales aux surfaces de contact (ce qui revient à négliger les frottements fondation-terrain) et proportionnelles aux déformations. D'où :  $p = kW$

k : module de réaction du sol  
p : pression exercée sur le sol  
W : déformation du sol

On distinguera deux modules de réaction : le module de réaction verticale  $k_V$  du terrain situé sous la base du massif et le module de réaction horizontale  $k_H$  du terrain entourant le massif, qui peut prendre plusieurs valeurs selon la nature des horizons traversés.

En supposant connues les coordonnées X et Y du centre instantané de rotation, on peut calculer les déplacements des points A, B et C du massif et les pressions PA, PB, PC qui s'y développent.

La résolution du problème se ramène alors à la détermination des trois inconnues  $\alpha$ , X et Y, pour laquelle on dispose des trois équations d'équilibre du massif.

Dans le cas du pont de Brotonne, le calcul a été effectué sur ordinateur, en considérant que le sol était constitué de trois couches de caractéristiques différentes et en négligeant les terres situées entre le niveau du terrain naturel + 4 et le plafond de la Seine - 5 (mort terrain). Le niveau de la nappe phréatique a été supposé à + 4.

On a représenté sur la figure 4 les résultats obtenus pour le cas de charge créant les contraintes extrêmes maximales sous la fondation (charges permanentes effets thermo-hygro-métriques et vent transversal). La compression maximale sur la craie atteint alors 24 bars, pour une rotation du massif de  $1,4 \times 10^{-3}$  radian. La compression moyenne maximale est égale à 16 bars sous surcharges d'exploitation.

Sur la partie droite de la figure a été tracé le diagramme des moments de flexion le long de la colonne. On constate que le moment de flexion à la base de la fondation est égal à une fraction relativement faible du moment des forces appliquées, environ le quart dans le cas considéré; cette valeur pouvant même devenir négligeable, si la hauteur de la colonne augmente ou si la raideur du terrain croît.

La rigidité de ce type de fondations est donc telle qu'elle limite les déplacements de l'ouvrage, vis-à-vis des efforts transversaux climatiques (vent) ou exceptionnels (chocs de bateaux dans le cas de fondations en rivière) tout en s'accommodant dans le sens longitudinal d'un encastrement élastique du tablier sur les piles.

Le calcul précédent supposant que le sol travaille dans le domaine des déformations pseudo-élastiques, il convient de vérifier, d'une part, que les pressions latérales sont inférieures aux limites pseudo-élastiques et, d'autre part, que les contraintes sur la base demeurent inférieures au tiers des contraintes de rupture.

### 3,2- Portance de la fondation

La contrainte de rupture  $q$  de la craie à la base de la colonne peut se déduire des caractéristiques pressionométriques :

$$q = q_0 + K (p_1 - p_0) = 70 \text{ bars}$$

avec :

$$p_1 - p_0 = 45 \text{ bars}$$

$$q_0 = 3 \text{ bars}$$

$$K = 1,5$$

La contrainte admissible est donc égale à 24 bars.

La détermination de la force portante de la fondation à partir des essais en laboratoire ( $\varphi = 20^\circ$ ,  $C = 5 \text{ bars}$ ) conduit à des résultats plus favorables :

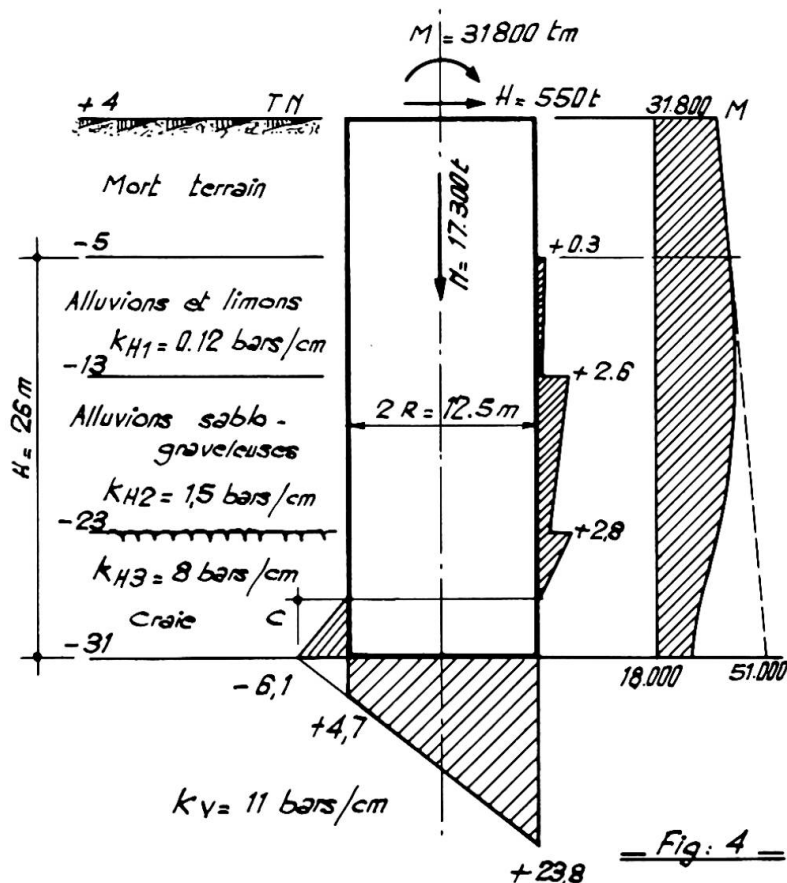

$$q = \gamma h \beta_q N_q + C \beta_c N_c = 99 \text{ bars avec :}$$

$$N_c = 14,8 \quad \beta_c = 1$$

$$N_q = 6,4 \quad \beta_q = 1,3$$

$$\gamma = 1 \quad h = 35 \text{ m}$$

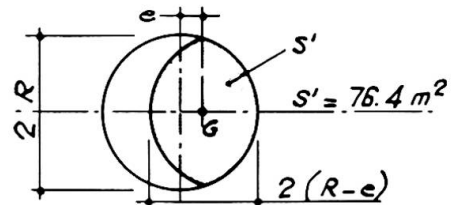

La contrainte admissible est égale à 33 bars pour un taux de travail du sol de :

$$\frac{17.300}{76,4 \times 10} = 22,6 \text{ bars}$$

Bien que la méthode pressiométrique soit plus sûre que les essais en laboratoire - ceux-ci ne portant que sur des échantillons intacts prélevés par conséquent dans les zones les plus saines de la craie, alors que le pressiomètre mesure plutôt les horizons les plus déformables de la roche - nous pensons que les fondations sur colonne profonde, encastrée dans le terrain, peuvent profiter pleinement du pouvoir porteur élevé du substratum. En effet, le moment de flexion transmis à la base de la fondation est réduit dans de fortes proportions par les réactions latérales du terrain, alors que l'effort normal est diminué également par les frottements fondation-terrain, qui ont été négligés dans les calculs précédents. Des contraintes moyennes plus élevées pourraient probablement être admissibles, si on pouvait réduire les dimensions de la fondation sans augmenter trop les déformations qui en résulteraient au niveau du tablier.

4- Problèmes d'exécution - Incidents

4,1- Exécution du cuvelage

Le cuvelage, de forme circulaire, travaille en anneau. En limitant, pour des raisons de stabilité élastique, la contrainte de compression du béton à 40 bars, une paroi moulée de 0,50 m. d'épaisseur suffirait. Pour se prémunir contre les imprécisions du forage, pouvant entraîner une ovalisation de la paroi, et le risque d'efforts de flexion parasites provenant d'une répartition inégale des pressions du terrain, il ne semble pas souhaitable de descendre en dessous de 0,60 m. Au pont de Brotonne, on a préféré exécuter une paroi non armée de 0,80 m. d'épaisseur plutôt qu'une paroi armée de 0,60 m. d'épaisseur.

Certains panneaux des parois moulées ont cependant subi des déviations qui conduisaient à un funiculaire de compression poussant au vide. Ces déviations dues, soit à un incident de bétonnage lors de la réalisation des joints entre panneaux, soit à la rencontre d'un point dur sous la benne de forage, ont nécessité des travaux confortatifs.

Ces travaux ont revêtu deux aspects :

Pour le pylône Rive Gauche, où deux panneaux seulement avaient dévié sur les 7 derniers mètres de la paroi - c'est-à-dire au niveau de la craie - un renforcement partiel a été effectué au droit des panneaux concernés. La continuité du cuvelage a été rétablie par bétonnage d'un élément intérieur lié à la paroi moulée par des armatures passives scellées dans cette dernière. La stabilité de forme du cuvelage était

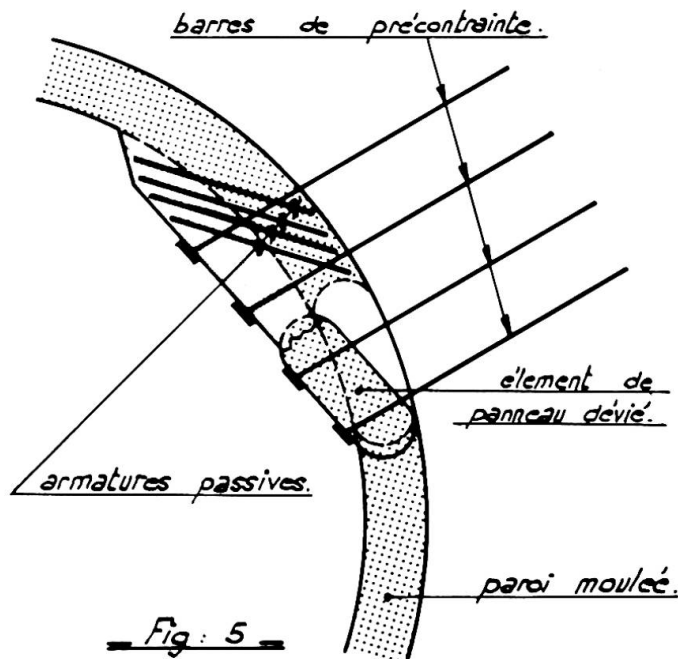

Fig: 5



assurée par des barres de précontrainte ancrées dans la craie et reprenant la poussée au vide (fig. 5).

Pour le pylône Rive Droite, par contre, il s'est révélé nécessaire de procéder à un renforcement général au moyen de cerces concentriques à la paroi. Les premières déviations se sont en effet produites au niveau des couches superficielles dans lesquelles il était aléatoire de s'ancrer. Un blindage intérieur continu a donc été réalisé jusqu'à l'intérieur de la craie franche par l'intermédiaire de cerces de 2 m. de hauteur, bétonnées au fur et à mesure de l'avancement du terrassement.

Le cuvelage a été exécuté par la Société Solétanche.

#### 4,2- Terrassements et superstructures

Le terrassement des colonnes s'est déroulé dans des conditions satisfaisantes au moyen d'un chargeur descendu au fond de la fouille, l'extraction de la craie ayant toutefois nécessité l'emploi d'un dérocteur.

Pendant l'exécution des terrassements, les fouilles ont pu être maintenues à sec par pompage, les débits d'eau en fin de travaux variant d'une colonne à l'autre de 50 m<sup>3</sup>/h à 105 m<sup>3</sup>/h. Afin d'éviter le risque de désagrégation de la craie à la base de la paroi moulée par suite des venues d'eau, le bouchon de béton inférieur de chaque colonne a été exécuté sous l'eau au tube plongeur, après contrôle du fond de fouille.

La superstructure des colonnes a ensuite été bétonnée à sec, à l'intérieur de coffrages glissants.

#### 5- Conclusions

La solution décrite permet de fonder économiquement des charges importantes (de l'ordre de 20.000 t. dans le cas du Pont de Brotonne) à de grandes profondeurs. De caractère massif, elle est plus résistante aux efforts horizontaux qu'une fondation sur pieux, et d'exécution plus sûre qu'une fondation sur caissons havés, dont la descente au niveau souhaité, est souvent difficile. Elle constitue donc une solution intéressante pour les fondations des ponts de grande portée.

#### RESUME

Les pylônes du pont de Brotonne, ouvrage haubanné de 320 m de portée centrale, sont fondés sur des colonnes cylindriques de 35 m de profondeur exécutées à l'abri d'un cuvelage autostable en paroi moulée servant de batardeau. La description de ce type de fondation, l'étude de sa stabilité et de sa portance, ainsi que l'analyse des conditions d'exécution sont traitées par les auteurs.

#### ZUSAMMENFASSUNG

Die Pylonen der Brotonnebrücke, einer Schrägseilbrücke mit einer Mittenstützweite von 320 m, sind auf 35 m hohen zylindrischen Säulen im Innern einer selbsttragenden aus Schlitzwänden erstellten, als Fangdamm dienenden Rüstung fundiert. Der Artikel dieses Gründungssystems behandelt vor allem seine Tragfähigkeit sowie die Ausführungsbedingungen.

#### SUMMARY

The towers of the Brotonne Bridge, a cable-stayed bridge with a 320 m center span, are founded on 35 m cylindrical columns; these are constructed within a self-supporting slurry trench wall acting as cofferdam. In this article the authors have mainly dealt with this type of foundation, its bearing capacity and the construction conditions.

## Multi-columns Foundation for the Tower Piers of a Suspension Bridge

La fondation en colonnes multiples pour les pylônes d'un pont suspendu

Gründung der Pylonen einer Hängebrücke mittels einer Vielzahl von Stützen

MASAMITSU OHASHI  
Dr., Manager

SATOSHI KASHIMA  
Dr., Design Engineer  
Honshu-Shikoku Bridge Authority  
Tokyo, Japan

OSAMU YOSHIDA  
Design Engineer

### 1. Introduction

Japan is an island country composed of four major islands and a few thousand of small islands. Bridges linking the islands have already been constructed over some straits. In area of the straits where the water is deep and the tidal current is fast, it is difficult to construct conventional solid foundations for the longer span bridges. Thus multi-columns foundation systems have recently been applied in these areas for the bridge foundations. A multi-columns foundation is a type of piled foundation, wherein columns are extended above water level and connected to a slab. Table 1 shows some examples of bridge constructed of the multi-columns foundation type.

The survey and research for the bridges linking two of the major islands (Honshu and Shikoku) was initiated almost 20 years ago and as a results of being near its conclusion, the construction of one of these bridges has recently been undertaken. The Honshu-Shikoku Bridge system over the straits of Seto Inland Sea will contain about 20 long span bridges, including suspension, truss, and arch bridges.

According to the plan, a multi-columns foundation will be used for one of the suspension bridges (Ohnaruto Bridge). The construction site of the Ohnaruto Bridge foundation is to be located in a fast current. In the planning and preliminary designing stages, research was conducted to check the applicability of multi-columns foundations for the suspension bridge towers, including investigation of the static and dynamic behavior of the foundation.(1,2) In addition to our research, some applied experience was obtained by the construction of the multi-columns foundation for the longer span bridge, Ohshima Bridge, which is a 3 span (100-200-100 m) continuous truss bridge constructed by the Japan Highway Public Corporation.(7)

### 2. Outline of Ohnaruto Bridge

Ohnaruto Bridge is a combined road and railroad bridge as shown in Fig.1. Fig. 2 shows the general view of the multi-columns foundation for Ohnaruto Bridge.

The main characteristics of the design condition at this construction site are as follows:

Table 1 Bridges Constructed on the Multi-Columns Foundation

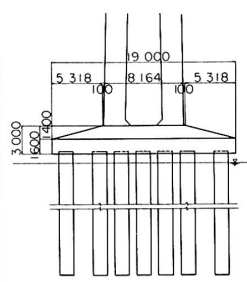
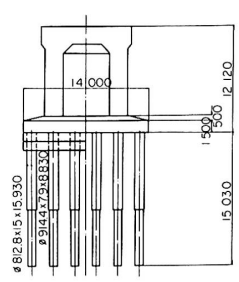
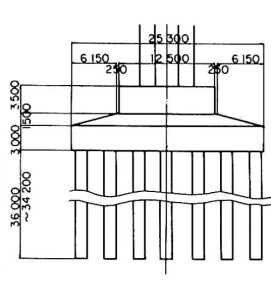
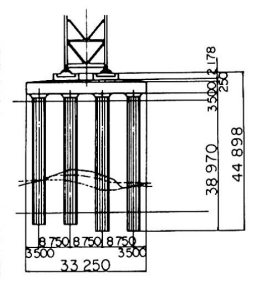
Name of Bridge	Biwako Bridge	Aoyagi Bridge	Katakami Bridge	Ohshima Bridge
Owner	Siga Prefecture	Gifu Prefecture	Okayama Prefecture	Japan Highway Public Corporation
Year of Completion	1964	1971	1974	1976(Expected)
Total Length of Bridge (m)	1350.0	185.75	520.0	725.0
Span Length of Bridge (m)	95-140-95, Others	20.6, 54.5-54.5-54.5	94-160-120-100	200-325-200
Type of Bridge	Continuous Steel Girder	Composite Girder, 3 Cont. Steel Girder	4 Continuous Steel Box Girder	3 Continuous Truss Girder
General View of Foundation				
(Ground Condition)	(Sandy Silt)	(Sandy Mudstone)	(Weathered Rhyolite)	(Granite)
Natural Period of A Foundation (sec)	1.0	0.42	0.83	0.68

\* All these details are taken from the plans of each bridge.

- (a) Depth of water: 3 m
- (b) Speed of tidal current: 5 m/s
- (c) Wind speed: 72 m/s
- (d) Ground condition: Sandstone

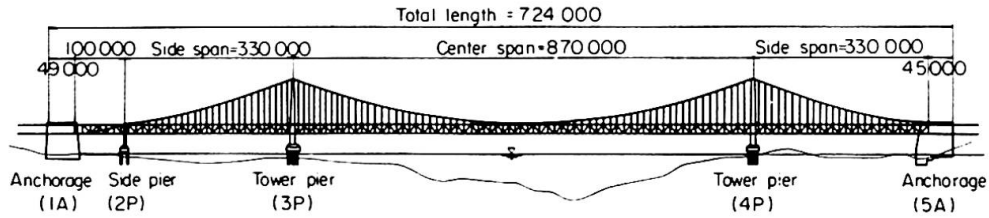

Fig. 1 General view of Ohnaruto Bridge Unit mm

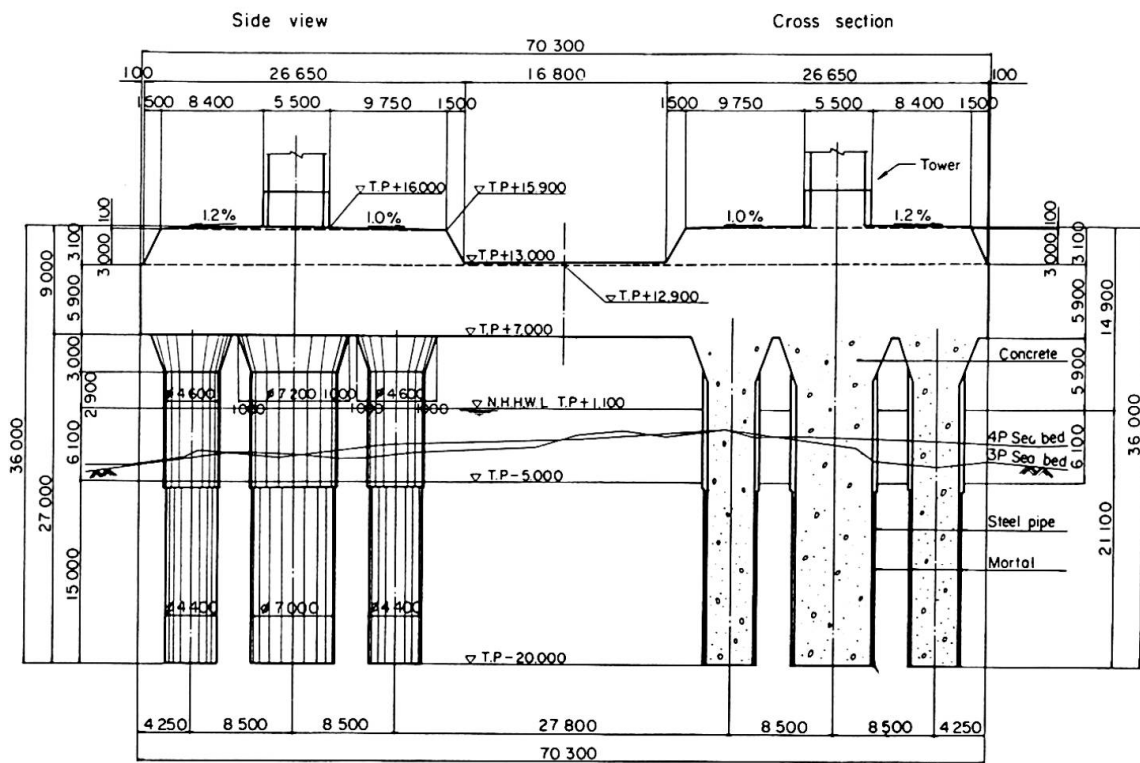

Fig. 2 General view of multi-columns foundation

### 3. Structural character of multi-columns foundation

A multi-columns foundation has more complicated interaction with the ground, as compared to a conventional solid foundation. It is quite complex to estimate the spring constant and bearing capacity of each column, and then combine the data to determine their interaction as a unitary group of columns. It is also difficult to consider the deep slab effect in the structural analysis and to specify the mass effect of the ground and dumping constant in the calculation of stability during an earthquake. Taking into account all these factors, it seems that a multi-columns foundation can best be analyzed by conceptualizing it as a space frame, as shown in Fig. 3. When a multi-columns foundation is conceptualized and analyzed as a space frame, it is very important to properly define the effective width of the beam and the rigidity of the connection between the beams and columns and to consider the shear deformation of the individual members.

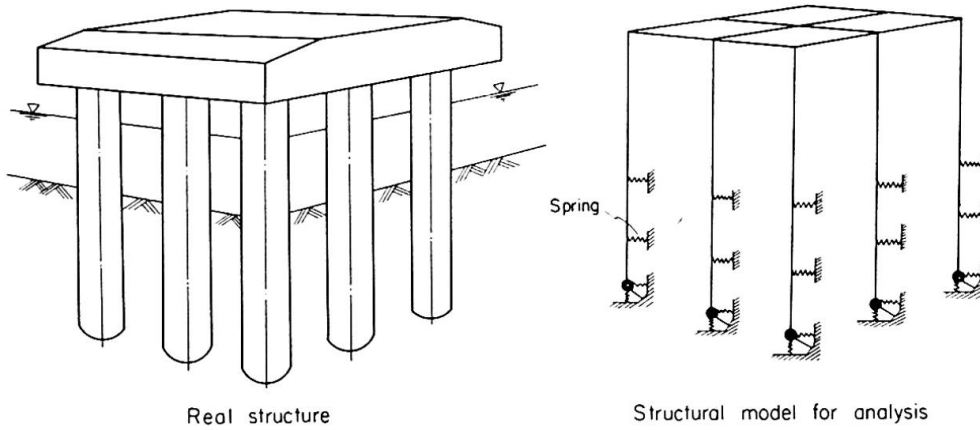

Fig. 3 Simplification of multi-columns foundation for analysis

In order to check the above mentioned method of analysis, some experimental models were built and tests were carried out upon them. Fig. 4 shows the large scale dynamic test model wherein a multi-columns foundation was set on the acrylic amide grouting gel connected to the shaking table.(1,2) In this test, the behavior of multi-columns foundation model was compared with that of a solid foundation model, by measuring the effect of ground deformation and coupled vibration of the tower and foundation. Additionally, dynamic tests of small scale models on sand and large scale models on the real ground were performed.(1, 2,4)

Statical tests of models constructed wholly of reinforced concrete were also performed to determine the load distribution on each column (see Fig. 5).(2)

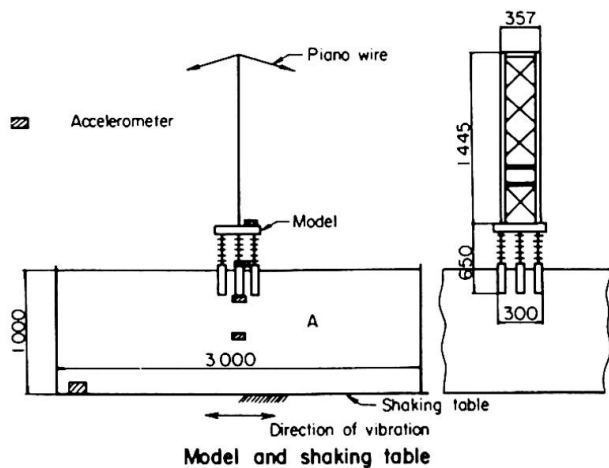
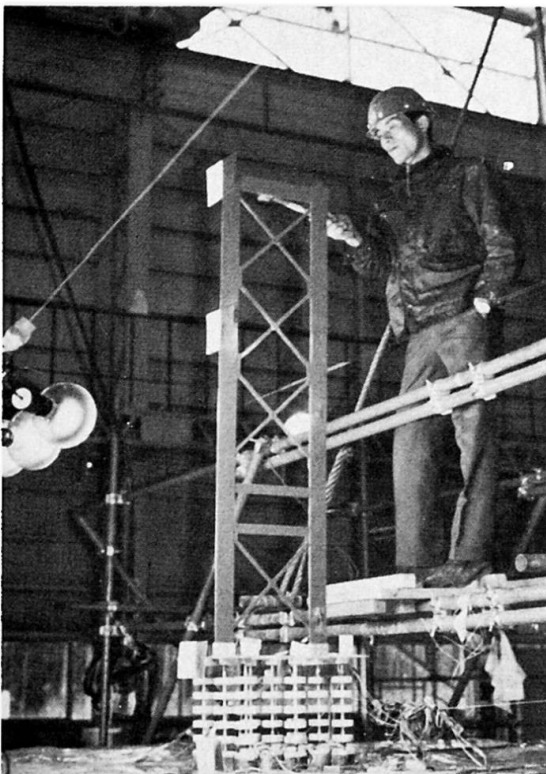

Fig. 4 Dynamic loading test for the tower pier model

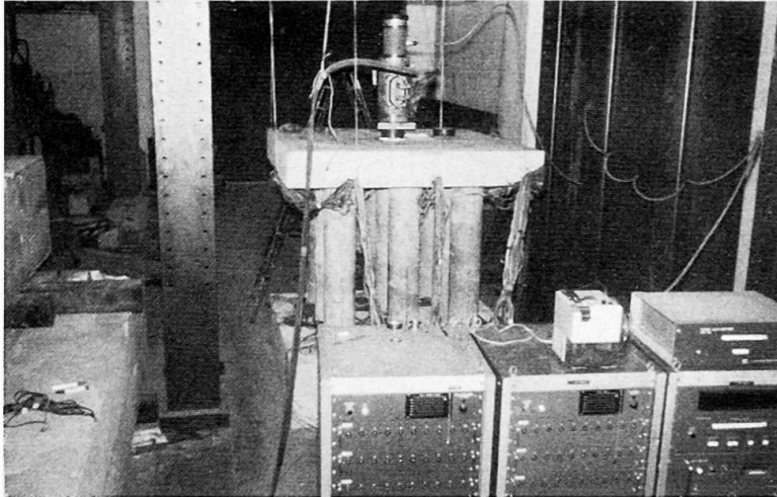

Fig. 5 Static loading test for the multi-columns foundation model

The followings were derived from the experiments:

(a) Although the deformation of the multi-columns foundation is larger than that of the conventional solid foundation, that effect at the tower top is negligible as shown in Fig. 6.

(b) The natural frequency of a multi-columns foundation is higher than that of a solid foundation which is designed to meet the same design conditions, because the weight of the multi-columns foundation is lighter than that of the solid foundation.

(c) Dynamic analysis of tower and multi-columns foundation can be done individually because of the large difference in their natural frequencies.

(d) The first mode of vibration occurs far more often than the others, because the top slab of the foundation is heavy.

(e) A multi-columns foundation can be analyzed as a space frame by the top slab to be a grid beam.

(f) It is assumed that the horizontal spring constant of the ground to the multi-columns foundation is equal to that of one column multiplied by the number of columns.

Therefore the design of the multi-columns foundation is considered to be reasonable as determined by these various experiments. The vibration tests on the foundations of the Katakami Bridge and Ohshima Bridge showed that it is a practical and feasible structure. (3, 8)

#### 4. Conclusion

It is practical and feasible to use the multi-columns foundation for the suspension bridge tower. The design procedure has been determined by both

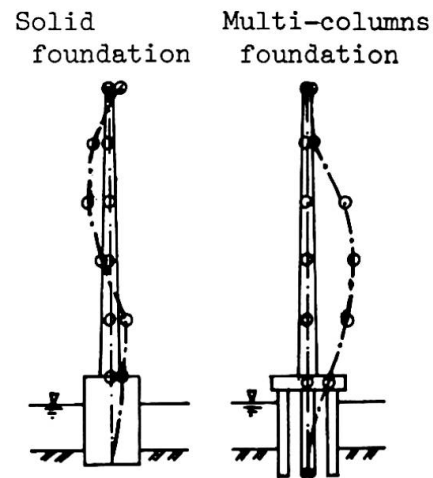

Fig. 6 Typical deformation of tower pier foundations

theoretical and experimental study and expanded upon by actual and increasing construction experience with that gained by various other construction entities.

## 5. Acknowledgements

The authors would like to acknowledge Mr. K. Komada, chief of the Design Section of Honshu-Shikoku Bridge Authority, for his help in writing this article.

## 6. References

- (1) Honshu-Shikoku Bridge Authority, Annual Research Report (1971) of the Honshu-Shikoku Bridge Projects, Tokyo, March 1972.
- (2) Honshu-Shikoku Bridge Authority, Annual Research Report (1972) of the Honshu-Shikoku Bridge Projects, Tokyo, March 1973.
- (3) Akihisa, S., "Design and Construction of Katakami Bridge," Bridge Engineering, Vol. 77, November 1975.
- (4) Takada, T., "Dynamic Tests of Multi-Columns Foundation," Tsuchi to Kiso, Vol. 20, No. 7, July 1972.
- (5) Kawashima, T., and Nishida, S., "Construction of Multi-Columns Foundation for Aoyagi Bridge," Bridge and Foundation Engineering, Vol. 4, No. 12, December 1970, pp. 35-40.
- (6) Tada, H., "Structural Character of Multi-Columns Foundation," Bridge and Foundation Engineering, Vol. 6, No. 9, September 1972, pp. 7-14.
- (7) Numata, K., and Okadome, H., "Construction of Ohshima Bridge Substructure (Multi-Columns Foundation Type)," Bridge and Foundation Engineering, Vol. 9, No. 2, February 1975, pp. 8-16.
- (8) Japan Highway Public Corporation, Report of Vibration Test for Ohshima Bridge (Substructure), Tokyo, March 1975.

## SUMMARY

The multi-columns foundation has been recently developed as a foundation to be utilized in construction across deep and fast straits. Applicability of such a foundation to the suspension bridge tower pier has been studied by theoretical analysis and model tests. It is concluded that the multi-columns foundation system for the suspension bridge tower pier is practical and feasible to use.

## RESUME

La fondation de pylônes avec colonnes multiples a été développée récemment comme fondation de ponts de ponts à travers des détroits profonds et à courants rapides. Une analyse théorique et expérimentale avec modèles devait étudier son utilisation possible comme fondation des piles principales de ponts suspendus. Les conclusions montrent que la fondation en colonnes multiples est une solution pratique et réalisable dans ce cas.

## ZUSAMMENFASSUNG

Die Gründung mittels einer Vielzahl von Stützen wurde in letzter Zeit für tiefe Meerengen mit erheblicher Strömung entwickelt. Die Anwendbarkeit einer solchen Gründung wurde durch Theorie und Modellversuche überprüft. Es zeigte sich, dass eine Gründung von Pylonen von Hängebrücken mittels einer Vielzahl von Stützen ausführbar ist und Vorteile bietet.

Deep Column Foundations of Large Bridge Piers

Fondations tubulaires profondes de ponts de grande portée

Tiefgegründete Stützenfundamente für Pfeiler von Grossbrücken

K.S. SILIN

Doctor of Technical Sciences, Professor

CNIIS of the Ministry of Transport Construction

Moscow, USSR

N.M. GLOTOV

Candidate of Technical Sciences

V.N. KUTZENKO

Candidate of Technical Sciences

Glavmostostroy of the Ministry of Transport Construction

Moscow, USSR

G.P. SOLOVYEV

Candidate of Technical Sciences

Reinforced concrete columns of thin wall hollow piles filled with concrete and bore piles (columns) with enlarged bases are widely used in the USSR as bridge foundations. Out of a great number of bridges recently constructed in the USSR the practice of erecting two exceptional bridges is of big interest. One of the bridges was erected on column foundations 3 m in dia socketed into bedrock, the other - on batter columns 1,4 m in dia with enlarged bases 3,5 m in dia embedded into compact clay.

The first railway bridge is made of seven steel spans each 158 m long mounted on piers in water. The river bed at the bridge crossing consists of alluvial gravel and sand deposits over inclined rock layers with ultimate compressive strength 300 to 1400 kgf/cm<sup>2</sup>. The alluvial deposits over the rock surface is 2 to 30 m thick. The river bed is about 22 m deep. The water level at high water rise<sup>s</sup> up to 8-10 m.

Foundations are designed as vertical columns made of 3 m reinforced concrete tubes filled with concrete. Because of inclined strata of rocky soils the foundation columns of two piers rest on gravel grounds (Fig. 1) and other five piers rest on bedrock (Fig. 2). Each column is loaded by 2500-30000tf, this load depends on the number of columns in a foundation.

Reinforced concrete pipes for columns were assembled section by section each 6 m long. Section flanges are fastened to each other with bolts. Pipe walls are 12 cm thick.



Sections are reinforced with a row of bar each bars being 25 mm in dia. Bars are welded to section flanges. Compressive strength of concrete is  $400 \text{ kgf/cm}^2$ . Flanges are welded at plants.

To install foundations means :

- to fabricate pipes ;
- to socket them into ground ;
- to spoil ground soil from the pipe ;
- to drill a hole in bedrock ;
- to fill holes with concrete mixture ;
- to cast foundation slab.

Pipe sections were fabricated in vibrating forms at a bridge site casting yard. Finished sections are delivered to assembly line and then they are transported to the installation site by pontoons.

To provide for designed in plan position of piles they were driven into soil (where each foundation is to be installed) through a template its preset designed in plan position being fixed.

The piles were embedded into soil with the help of a vibrating unit whose disturbing force was equal to 280-340 tf. Vibrating unit was fastened to the top of a pile with a clamping cap.

At the first stage the piles were driven by vibrating unit at a rate of 1.5 - 2 m/min, if in the pile hole there was a soil core 2 - 3 m high. As long as the core grew up the rate of penetration was cut down to 1.0 - 0.5 m/min. The rate of penetration through the bottom stratum of dense gravel soils was less than 0.1 m/min even at the absence of a core.

To increase the rate of penetration through such of soils they were spoiled below the pile edge for 0,8-1,2 m. Under these conditions pile sections were filled with water to a level higher than that of the river surface for 4-5 m, thus resulting in extra hydrostatic pressure which served as a barrier against possible collapse of cohesionless soils in the uncased hole. That extra pressure was kept up all the time the pile was driven to a design elevation.

So as to install foundations for five river piers the piles were driven down through alluvial deposits to the very bedrock surface. The rock then was drilled through the pile hole for the depth of 3-3.5 m. Diameter of the drill hole was 2.6 m. It was furnished with reinforcing bars and filled with concrete mixture with the purpose of to anchor columns into rocks so that they could sustain designed loads. The holes in the bedrock for the pile base were drilled by the RTB-2600 drilling machine developed at the All-Union Research Institute for Boring Equipment of the Ministry of Oil Industry of the USSR. The machine consists of four turbo-drills which are in mass production for oil industry. They are unified into a fixed plain structure. These turbo-drills operate at a time, the fourth one without a bit is reserve. External turbo-drills are fit with cone bit 490 mm in dia, internal one - 750 mm. The turbo-drills are driven with water which is pumped through hoses under pressure of 30-50 kgf/cm<sup>2</sup>.

In the course of drilling small particles of broken rock were pumped out with water. Coarse particles were periodically sucked with air-lift. Altogether 50 holes for foundations were drilled, average rate of drilling being 0.4 m/hr.

Every hole drilled to a design elevation was cleaned of muck. The reinforcing cage was then installed into the pile and hole and the concrete was poured down through a tremie. A special pipe with a hopper at its bottom end was pushed down the hole to clean it completely.

At a pressure of 7 kgf/cm<sup>2</sup> the water was pumped down through the pipe, sucked with the muck into the hopper and settled down there.

The concrete mixture was poured through a tremie 0.3 m in dia at a depth of 28 m.

The quality of concrete laid down into holes was checked due to test results of samples prepared from bored cores. According to compression test data the concrete strength was about 210 to 410 kgf/cm<sup>2</sup>. Designed compression grade is 200.

It took 3-4 days to install a column 3 m in dia and fix it into bedrock.

The columns driven to design elevation and filled with

concrete were coupled by a foundation slab which served as a base for a cast-in-place concrete pier.

Foundations made of batter columns with enlarged base were implemented in a railway bridge over a broad river in a northern zone of the country.

Under the bridge area lies a stratum of fine-grain sands 10-25 m thick over Paleogene clays of stiff plastic consistency with a safe pressure of  $6 \text{ kgf/cm}^2$ . The river depth at low water is 5-9 m, at high water 10-14 m. The bridge erected the river bed at piers will be washed out to a depth of to 12 m.

Each of 13 river piers bears a span structure 132 m long. Foundations of river piers are made of batter bore columns 1.4 m in dia (rate of batter from 15:1 to 5:1) with enlarged base 3.5 m in dia embedded into Paleogene clays at a depth of 40 m from low water level (Fig. 3).

Every column is armed with a reinforcing cage 1.16 m in dia, 25 m long. Every cage is made of bars 28 mm in dia and spirals 15 cm in pitch.

Upper part of columns at a depth of 12 m. below the foundation slab is encased with a steel pipe (its wall is 10 mm thick) to protect concrete columns from sand abrasion at high water.

Compressive strength of concrete used in columns and foundation slabs is 400.

Designed load per each column is 800 tf. Static tests of columns proved that the bearing capacity of columns in soils is twice more than the designed load on a column.

Complex of operations in erecting each foundation comprised as follows :

- preparation of construction site for boring equipment ;
- drilling of holes ;
- installation of reinforcing cages ;
- pouring of concrete into holes ;
- excavation of pits and concreting the slab.

Boreholes were drilled with a mobile drilling machine consisted of a pile driver (lifting capacity 20 t) with a jib 35 m long containing a drilling mechanism with a motor and a hollow rod 40 m long. At the bottom of the rod is fastened an auger bucket of  $1 \text{ m}^3$  of capacity. At the top of the bucket there are blades of expander with a hydraulic drive to close and open them.

Holes were drilled with a cyclic procedure. First they were drilled at a depth of 0.6-0.7 m, then the soil was excavated. In the process of drilling the holes were filled with bentonite slurry to protect the hole from possible sand slides. Then the hole was filled with a reinforcing cage and concrete mixture.

The top of the borehole was encased with a ring 1.7 m in dia to prevent its walls from failure.

While drilling deep there was a fear that the batter holes would be deflected. Therefore after drilling is over their alignment was checked with a special device which is widely used in oil drilling.

As observations showed the hole axis at its bottom was declined from the straight line usually for 40 cm per 40 m of the hole length, which was considered as quite normal.

These deflections might have been much more if there have not been two centralizers fixed along the rod of the drilling machine.

After measuring deflections in every hole they (holes) were arranged with a reinforcing cage and casted with concrete mixture through a 0.3 m dia tremie.

It took 1-2 days to mount a pile. A foundation pit done the upper part of all concrete columns were cut for 0.7-0.8 m to remove weak concrete with grains of broken muck.

The foundation slab then was laid down in accordance with a well known technology of erecting a bridge foundation slab made of cast-in-place piles.

#### SUMMARY

The article deals with the conception and execution of two large bridges. In one of them the foundations were made of columns 3 m in diameter stocketed into bedrock. In the other case they were made of bore piles 1.4 m in diameter with an enlarged base 3.5 m in diameter embedded into clays.

#### RESUME

La conception et l'exécution de deux grands ponts sont décrites. Les fondations de l'un de ces ponts reposent sur les faisceaux de pieux tubulaires de 3 m de diamètre et les fondations de l'autre consistent en pieux forés d'un diamètre de 1.4 m à base élargie de 5 m de diamètre, enfoncés dans l'argile.

#### ZUSAMMENFASSUNG

Konzept und Herstellung von Fundamenten für zwei Grossbrückenbauten werden beschrieben. Bei einer der Brücken besteht die Gründung aus im Fels eingespannten Pfählen von 3 m Durchmesser. Die zweite Brücke ruht auf in lehmigen Böden eingebrachten Bohrpfählen von 1.4 m Durchmesser mit Fussverbreiterung auf 3.5 m.

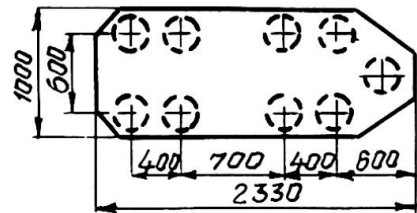
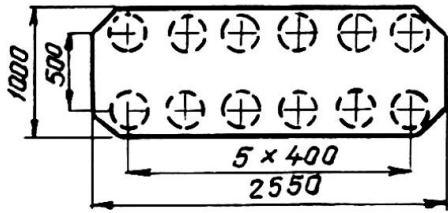
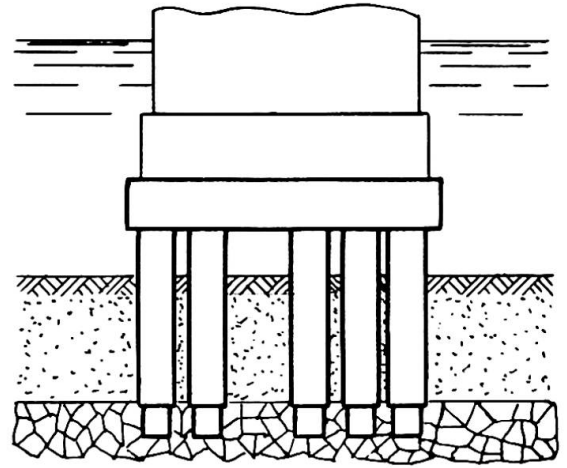
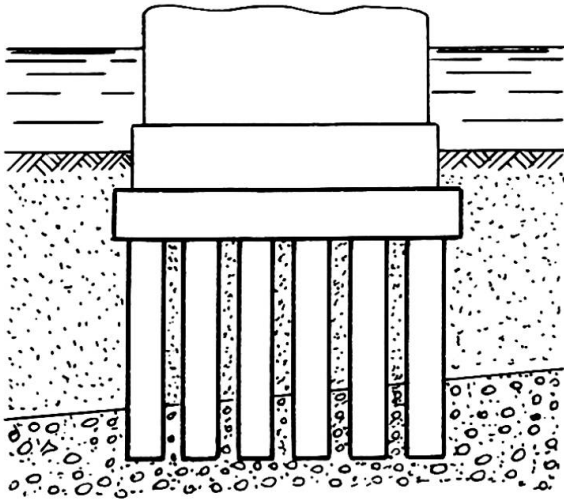

Fig. 1

Fig. 2

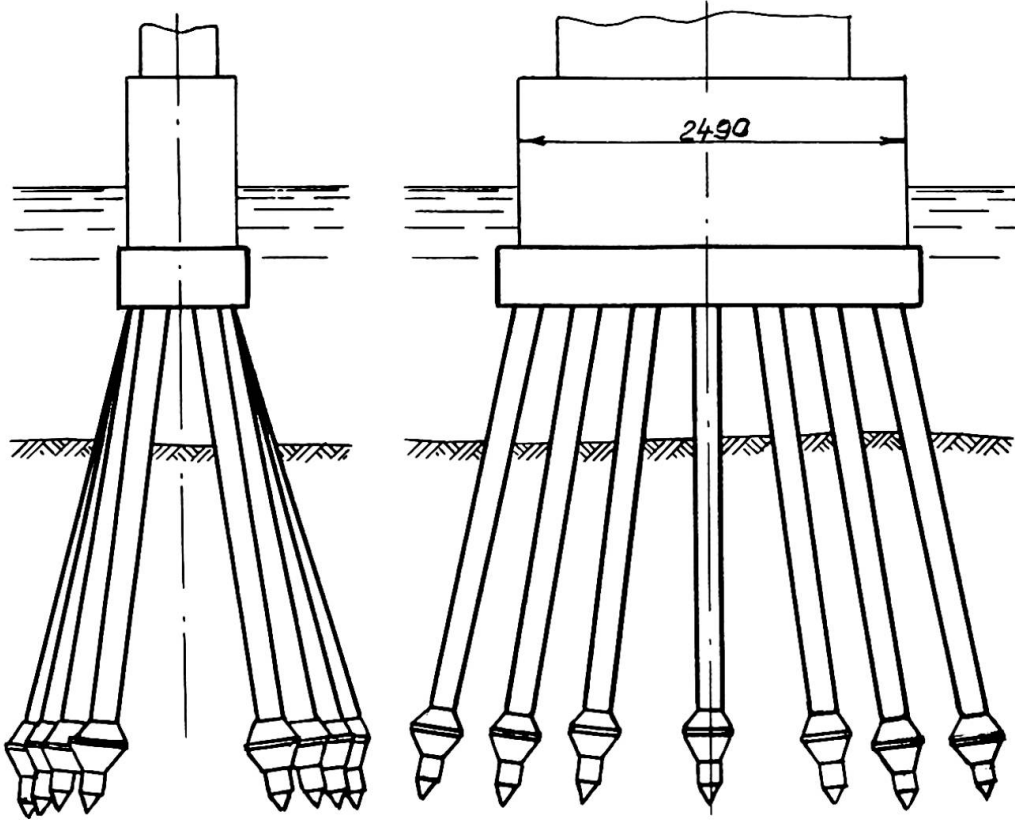
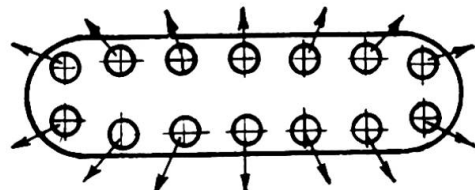

Fig. 3



## Sheet Pile Foundation and Design Method

Fondations en palplanches et dimensionnement

Spundwandgründungen und deren Bemessung

TADAYOSHI OKUBO KEIICHI KOMADA KANAME YAHAGI MICHIO OKAHARA  
Public Works Research Institute, Ministry of Construction  
Tokyo, Japan

### 1. INTRODUCTION

For the construction works in water cofferdam cells are generally needed so that they can be performed in the dry. In the design of cofferdam cells consideration must be given to the dimension of the area to be drained and to the head of water, earth pressure, waves, tides and so on, acting on the cells. For the purpose that the construction works in water can be done safely and economically, the sheet pile foundation method, described in this paper, has recently been developed and adopted widely in Japan. The characteristics of this method may be said as follows.

(1) The walled sheet pile foundation is built both as the main foundation structure and the temporary cofferdam cell. The cost and the period of construction by this method are less than by the ordinary methods.

(2) The flexural rigidity of this foundation can be expected to be similar to that of the caisson foundation, considering the shear resistance at joints & the rigid connection at footing in this foundation.

As the sheet pile foundation is considered to have lots of benefits in the construction works in water, in this way, it may greatly be noticed as a new type foundation.

Table 1 Construction works

### 2. CONSTRUCTION WORKS & STRUCTURAL CHARACTERISTICS OF THE SHEET PILE FOUNDATION

The sheet pile foundation was firstly adopted for a blast furnace foundation in 1965 and for the bridge foundation in 1969. The construction works by this method have become popular since that time and the total number of the works are about 150 for 40 bridges, for example, as of 1975. Table-1 shows the construction works of sheet pile foundation having large-

name of bridge	date of start	basic dimensions		
		cross sectional dimensions of foundation	dimensions of steel pipe pile	number of foundation
Ishikari kako	1969. 6	8,877 x 20,483	812.8 x 16 x 42,000	2
Nanko renraku	1971.11	∅ 15,210	1,219 x 13 x 33,000	3
"	1971.11	13,350 x 35,290	1,219 x 13 x 33,000	4
Shibatani heiya	1972.12	15,727 x 20,376	914.4 x 14 x 34,500	6
Minami huta renraku	1973. 2	22,225 x 15,008	1,200 x 14 x 28,000	2
Suehiro	1973. 3	∅ 24,508	914.4 x 14 x 39,600	2
Ishikari	1973. 5	∅ 15,488	800 x 14 x 20,000	2
Shin Ebetsu	1973. 6	∅ 15,506	800 x 16 x 27,000	3
Rokko island renraku	1973. 9	10,568 x 25,193	1,219.2 x 16 x 31,000	5
Shin Suigo	1973.11	26,445 x 16,186	1,219.2 x 19 x 57,500	4
Shin Kagasuno	1974. 3	∅ 18,684	914.4 x 14 x 44,000	4
Senboku renraku	1974. 5	26,058 x 14,322	1,219.2 x 16 x 42,550	2

dimensions. These sheet pile foundations become to be used in such large foundation structures as caisson foundations or large pile foundations. The sheet pile foundation is composed of steel pipe piles shown in Fig. 1, which are connected

each other through joints and driven into bearing strata in a circular, oval or rectangular closed form as shown in Fig. 2. Since this foundation uses steel piles,

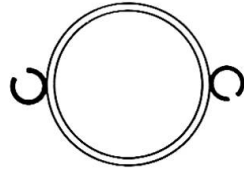

Fig. 1 Steel pipe pile

it has such advantages that the construction works can be rationalized and completed within a comparatively short period of time, and that the penetration length can be chosen arbitrarily. In case of the caisson foundation, its cross sectional contour greatly influences the speed of the construction works. The constructing work of the sheet pile foundation, however, is little different from the conventional piling work, which is scarcely influenced on the work in spite of the size of the sectional contour.

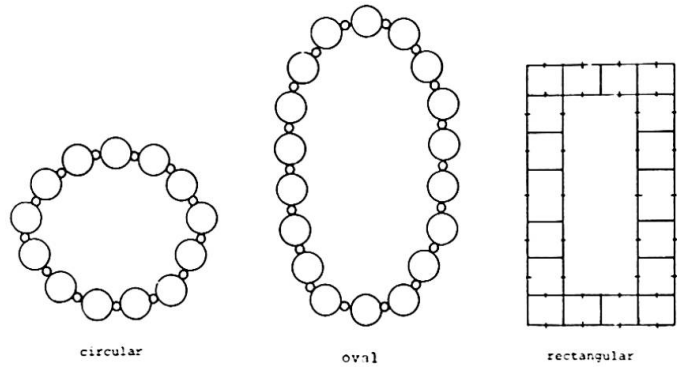

Fig. 2 Sectional forms

The sheet pile foundation has been developed as a sort of under-water construction method. It is divided into three types according to means of use, which are shown in Fig. 3. A is called the "Rising type foundation" of which the footing is above water surface. This type does not need a temporary cofferdam structure and its structure is similar to the multipile foundation. B is called the "Conventional type foundation" of which a closing wall is built independently on the foundation body. The temporary structure is the same to one of the conventional piling work in water. Its footing form is the same to one of A. C is called the "Cofferdam cells type foundation" of which the wall is used both as the main foundation body and the temporary structure concurrently. This is a unique type and has many remarkable merits. As a matter of fact, this C type foundation has adopted in most of sheet pile foundations already constructed. The design for the wall must be done by taking into consideration the hydraustatic and earth pressure for closure of the water in addition to design forces for the main structure. Fig. 4 shows several construction steps of this type.

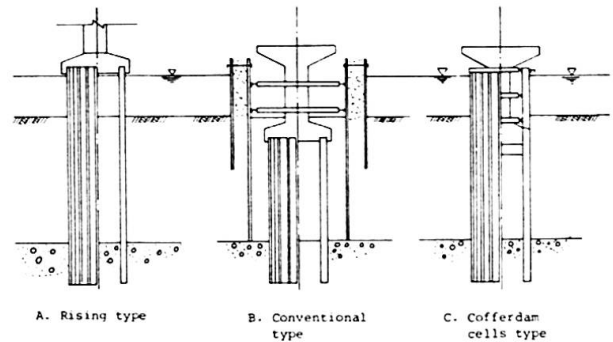

Fig. 3 Types of sheet pile foundation

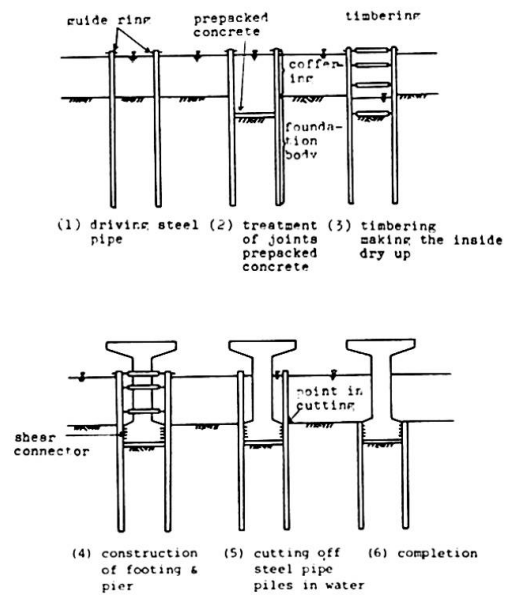

Fig. 4 Several steps in working "Cofferdam cells type"

The joints are generally treated by means of being filled with mortar in order to increase the flexural rigidity of the wall or to make water tight in case of the "Cofferdam cells type foundation". There are two kinds of the footing types. One is applied in the A type or the B type in Fig. 3. Its structure is the same to one of the conventional pile foundation. The other is used in the "Cofferdam cells type foundation" and is constructed inside the cylindrical wall. The connection between the wall and the footing is executed with shear plates and reinforced bars welded on sheet piles shown in Fig. 5.

3. EXISTING DESIGN METHOD

The "Guidance for Design and Construction of Sheet Pile Foundation" was proposed by Research Committee for Sheet Pile Foundation in January 1972. Its principal points are as follows. It is assumed that the sheet pile foundation is on an elastic media shown in Fig. 6. Its lateral resistance shall be calculated by the following formula.

$$\left. \begin{aligned} EIy^{(4)} + ky &= 0 \\ EI &= E \{ (I_i) + \mu (A_i y_i^2) \} \end{aligned} \right\} \quad (1)$$

where,  $I_i$  : Moment of inertia of i-th pile  
 $A_i$  : Sectional area of i-th sheet pile  
 $y_i$  : Distance from center axis of foundation to one of i-th sheet pile

When the flexural rigidity EI is calculated, the effect is considered such that each sheet pile is composed of each joint and the footing. The EI value is evaluated by the composite efficiency  $\mu$ . The coefficient  $\mu$  ranges 0.0 to 1.0. In case of joints grouted with mortar, the  $\mu$  is usually taken to be 0.5.

4. NUMERICAL ANALYSIS BY FINITE STRIP METHOD

For the purpose of analyzing theoretically the structural properties of the sheet pile foundation, a computer program by F.S.M. (Finite Strip Method) has been completed in which three-dimensional deformation of beam, shear deformation at joints and sectional deformation are considered. Following Assumptions are given for analysis.

- (1) The circumference connecting centroids of each sheet pile is circular as shown in Fig. 7.
- (2) The relationship between displacement of joint and shear force acting on it is proportional. This joint is also hinged on the section.
- (3) Each sheet pile has no sectional deformation.
- (4) The material of the ground is elastic.
- (5) Ground conditions, shape of foundation and external forces are symmetrical to axis as shown in Fig. 7.

In case a supposed shell in Fig. 7 is considered, the central plane of this supposed shell coincides with the circumference of the cylindrical wall. It is assumed that the central axis of each sheet pile is connected with the central plane of this supposed shell and these have the same displacement. Considering the deformed section of the cylindrical wall at the central plane of the supposed shell, the section of the supposed shell is a continuous line, but one of the wall is hook-shaped as shown in Fig. 8.

The unit vectors on the central plane of the supposed shell are shown in Fig. 7. The displacement vector  $U_0$  in Fig. 9 on the central plane of the supposed shell is given by the unit vectors  $(\vec{e}_s, \vec{e}_n, \vec{e}_z)$

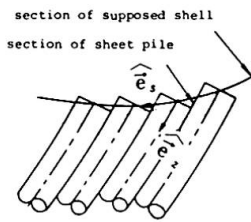

Fig. 8 Deformation of supposed shell and sheet pile

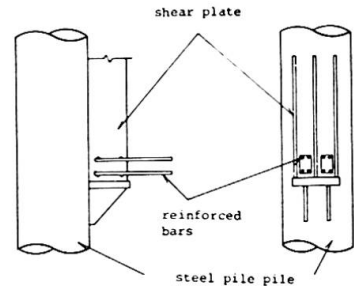

Fig. 5 Connection feature

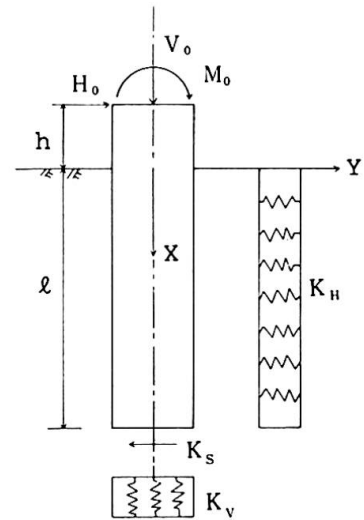

Fig. 6 Structural model

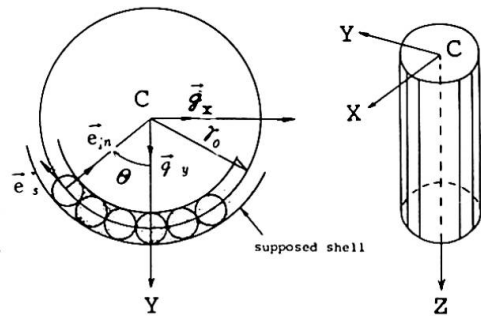

Fig. 7 Coordinate system

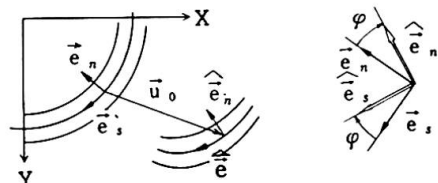

Fig. 9 Angular displacement of supposed shell



$$\bar{U}_0 = \xi_0 \bar{e}_x + \eta_0 \bar{e}_y + \zeta_0 \bar{e}_z \quad (2)$$

The angular displacement  $\varphi$  of the supposed shell in Fig. 9 is expressed by a finite series.

$$\varphi = \sum_{k=1}^K \left\{ \alpha_k(Z) \cdot \text{sink} \theta \right\} \quad (3)$$

where,

$$\theta = 0, \pi; \quad \varphi = 0$$

The shear strain  $(\gamma_{xz})_0$  on the central plane of the supposed shell can be assumed as for a finite series by the beam theory.

$$(\gamma_{xz})_0 = \sum_{j=1}^J \left\{ \beta_j(Z) \cdot \text{sin} j \theta \right\} \quad (4)$$

The coefficients of eq. (2) are obtained by eq. (3) and eq. (4).

$$\xi_0 = -Vc(Z) \cdot \text{sin} \theta - \gamma_0 \sum_{k=2}^K \left\{ \alpha_k(Z) \cdot \frac{1}{k^2 - 1} \cdot \text{sink} \theta \right\} \quad (5a)$$

$$\eta_0 = -Wc(Z) \cdot \text{cos} \theta - \gamma_0 \sum_{k=2}^K \left\{ \alpha_k(Z) \cdot \frac{k}{k^2 - 1} \cdot \text{cos} k \theta \right\} \quad (5b)$$

$$\zeta_0 = -Wc(Z) \cdot \gamma_0 \text{cos} \theta \cdot Vc(Z) - \gamma_0 \sum_{j=1}^J \left\{ \frac{1}{j} \cdot \text{cos} j \theta \cdot \beta_j(Z) \right\} - \gamma_0^2 \sum_{k=2}^K \left\{ \frac{1}{k(k^2 - 1)} \cdot \text{cos} k \theta \cdot \alpha_k(Z) \right\} \quad (5c)$$

Getting displacements on the central plane of the supposed shell, displacement of each sheet pile and sliding displacements of joints are known. The displacement vector of a sheet pile,  $\bar{U}$  is given as follows.

$$\bar{U} = U \cdot \bar{e}_x + V \cdot \bar{e}_y + W \cdot \bar{e}_z \quad (6)$$

$$U = \xi_0 - y \cdot \varphi, \quad V = \eta_0 + x \cdot \varphi, \quad W = W_0 - x \cdot \xi'_0(Z) - y \cdot \eta'_0(Z) \quad (7)$$

The sliding displacement of the  $i$ -th joint,  $(\Delta W)_i$  is given as follows.

$$(\Delta W)_i = -\gamma_0 \sum_{j=1}^J \left\{ (A_j)_i \cdot B_j \right\} - \gamma_0^2 \sum_{k=2}^K \left\{ (B_k)_i \cdot \alpha_k(Z) \right\} \quad (8)$$

where,

$$A_j = \frac{1}{j} \left\{ \left[ \text{cos}(j \cdot \Delta \theta) - 1 \right] \cdot \text{cos} j \theta - \text{sin}(j \cdot \Delta \theta) \cdot \text{sin} j \theta \right\} \quad (9a)$$

$$B_k = \frac{1}{k(k^2 - 1)} \left\{ \left[ \text{cos}(k \cdot \Delta \theta) - 1 + \frac{b}{2\gamma_0} \cdot k \text{sin}(k \cdot \Delta \theta) \right] \cdot \text{cos} k \theta - \left[ \text{sin}(k \cdot \Delta \theta) - \frac{b}{2\gamma_0} \cdot k \left[ \text{cos}(k \cdot \Delta \theta) + 1 \right] \cdot \text{sink} \theta \right] \cdot \text{sin} k \theta \right\}, \quad \Delta \theta = \theta_{i+1} - \theta_i \quad (9b)$$

Using the strains of a sheet pile obtained by eq. (6) and eq. (7), and the sliding displacement of a joint in eq. (8), the equilibrium equations and the boundary conditions are obtained by the principle of virtual works. These can be solved numerically. Once the part between the plane,  $Z = 0$  and the plane,  $Z = \ell$  in Fig. 7 is settled into a finite element, the displacement parameters  $Wc$ ,  $Vc$ ,  $\alpha_k$ ,  $\beta_j$  are expressed by suitable series which satisfy compatibility conditions.

$$\begin{aligned} Vc &= g_1 Vc^{(0)} + g_2 Vc^{(\theta)} + \ell \cdot g_3 \cdot Vc^{(0)'}(Z) + \ell \cdot g_4 \cdot Vc^{(\theta)'}(Z) \\ \alpha_k &= g_1 \alpha_k^{(0)} + g_2 \alpha_k^{(\theta)} + \ell \cdot g_3 \alpha_k^{(0)'}(Z) + \ell \cdot g_4 \cdot \alpha_k^{(\theta)'}(Z) \\ Wc &= \tilde{g}_1 Wc^{(0)} + \tilde{g}_2 Wc^{(\theta)}, \quad \beta_j = \tilde{g}_1 \cdot \beta_j^{(0)} + \tilde{g}_2 \cdot \beta_j^{(\theta)} \end{aligned} \quad (10)$$

where,

$$\begin{aligned} \tilde{g}_1 &= 1 - \mu, \quad \tilde{g}_2 = \mu, \quad g_1 = 1 - 3\mu^2 + 2\mu^3 \\ g_2 &= 3\mu^2 - 2\mu^3, \quad g_3 = \mu - 2\mu^2 + \mu^3, \quad g_4 = \mu^3 - \mu^2, \quad \mu = \frac{z}{\ell} \end{aligned} \quad (11)$$

By using the computer program based on the above-mentioned theory, local stresses of each sheet pile against a lateral force are principally investigated. Fig. 10 shows the model for calculation. Fig. 11 shows some of the results of the comparison between experimental stress distributions and theoretical ones. In Fig. 11, three theoretical values are shown. The theoretical value (1) is calculated under the conditions of the sliding rigidity of joints (120,000 t/m<sup>2</sup>) and the ground model complied with Fig. 10, and the theoretical value (2) under ones of (60,000 t/m<sup>2</sup>) and the ground model of the same to (1). The theoretical value (3) is calculated under ones of (120,000 t/m<sup>2</sup>) and the lateral ground

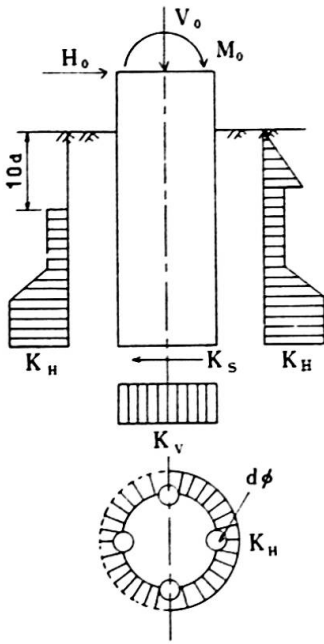

Fig. 10 Ground model

coefficient  $K_H$  which is constant regardless of the depth. In case the sliding rigidity of joints has lower value, there appear tendencies that the restraining stress near the footing becomes greater and that the maximum stress in the middle of ground decreases. Both of the theoretical values (1) and (2) are close to the experimental values as for the feature of stress distribution. There is, however, some difference between them as for the positions of local stresses. The theoretical value (3) catches the experimental values as a whole.

The notable local stresses both of the experimental and theoretical can be looked. The larger, the sheet pile foundation becomes, the more appears noticeable differences between each stress distribution by this F.S.M. and that by the existing method.

5. APPLICATION TO DESIGN

Principal points of the Guidance in Section 3 are described. In Section 4, the F.S.M. theory is shown which takes into consideration the relative displacement of each pile and the sectional deformation.

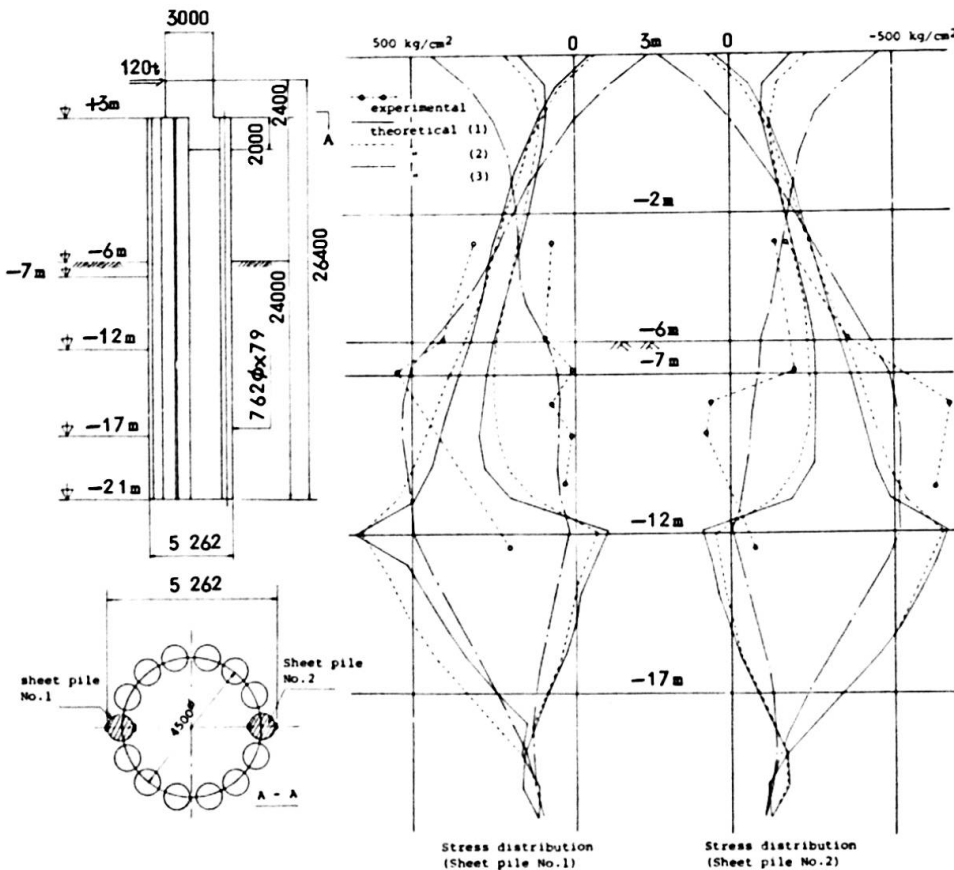

Fig. 11 Stress distribution

When this theory is applied to real models, local stresses of sheet piles can be calculated reasonably. As it is concluded from the results that the mechanical properties of the structure can insufficiently be explained by the existing design method, more rational design methods should be substituted for the conventional ones.

Some of the studies for solving these subjects are briefly shown as follows. First of all, the simplest method is one added the eq. (1) to the term of shear deformation. Its basic formula

is given as follows.

$$Ely^{(4)} - \frac{EI}{GA} \cdot ky'^2 + ky = 0 \tag{12}$$

Considering the relative displacement in each joint, the basic formula is given as follows.

$$\frac{EI^*}{GA} \cdot EI_p y^{(6)} - E(I^* + I_p) y^{(4)} + \frac{EI^*}{GA} ky'' - ky = 0 \quad (13)$$

where,

$$EI = E [A_i y_i^2], \quad EI_p = [I_i]$$

GA : Shearing rigidity      k : Spring constant of ground

It is impossible to obtain the general solution of eq. (12) and eq. (13). But eq. (12) or eq. (13) can be calculated by using a method like F.E.M.

Besides the mentioned methods above, a design of the sheet pile foundation can be made by using the design methods both of the pile foundation and the caisson foundation. The mechanical properties of the sheet pile foundation may be evaluated by the interpolation between their foundations. In case of this method, if the effect of shear transmission in joints is great, it is similar to the caisson foundation, and if in opposition, similar to the pile foundation,

Three methods above-mentioned and the conventional methods have equally both some merits and some demerits according to the size and the shape of the sheet pile foundation. Its design method should be investigated by means of the F.S.M. program shown in Section 4 and so on.

## 6. CONCLUSION

The sheet pile foundation has developed mainly as a method of construction works in water. It has so a wide range of dimensions that the existing method is not good enough to cover such an applicable range of designs. In this paper, its lateral resistance against earthquake forces is discussed. The program of F.S.M. shown in Section 4 is completed and hereafter its structural properties is analyzed. There is also another important subject which is the reliability of the rigid connection between the wall and the footing including the residual stress. Anyway, the sheet pile foundation has been used for about ten years, therefore, design standards should be established in the near future.

## SUMMARY

The sheet pile foundation is a new type foundation. Structurally, this foundation differs conspicuously from the conventional types of deep pile foundation or caisson foundation. The process of development of the sheet pile foundation refers to the actual results obtained in its construction work, and its structural features. The design method in use is introduced and problems involved are analyzed. With a view to establish a rational design method, the structural features of the sheet pile foundation have been put to analysis in a computer program using the Finite Strip method. The theoretical background and part of the results of calculations are presented.

## RESUME

La fondation en palplanches est un nouveau type de fondation. Elle présente des différences évidentes par rapport aux types existants de fondation profonde, telles que pieu ou caisson. Les exemples de travaux et les caractéristiques de la fondation en palplanches sont donnés. La méthode courante de calcul et certains problèmes sont évoqués. Une méthode de calcul pratique à l'ordinateur, tenant compte des caractéristiques structurales, est développée à l'aide de la méthode des bandes finies. La base théorique et une partie des résultats des calculs sont présentées.

## ZUSAMMENFASSUNG

Die Spundwandgründung ist eine neuartige Gründungsform. Sie unterscheidet sich in konstruktiver Hinsicht wesentlich von den herkömmlichen Pfahl- und Senkkastengründungen. Die Entwicklung der Spundwandgründung, ihre Ausführung und ihre konstruktiven Eigenschaften werden aufgeführt. Dazu werden die zur Zeit eingesetzten Berechnungsverfahren dargelegt und die damit verbundenen Probleme erörtert. Die Berechnung dieser grosse Vorteile bietenden Konstruktionsart erfolgt elektronisch nach der Finite Strip Methode. Der theoretische Hintergrund und die wichtigsten Berechnungsergebnisse werden dargestellt.

**Model Test for Design of Long Span Bridge Foundation**

Essai sur modèle des fondations de ponts de grande portée

Modellversuch für die Bemessung von Fundamenten weitgespannter Brücken

**S. SUZUKI**

Chief

Hamana By-Path Construction Office, Japan Highway Public Corp.  
Tokyo, Japan**M. ISHIMARU**

Project Engineer

**F. NEMOTO**

Manager

Hamana Ohashi Construction Office, Kajima Corp.  
Tokyo, Japan**Y. NOJIRI**

Assistant Head

Kajima Institute of Construction  
Tokyo, Japan**1. Introduction**

As the span of bridge is increasing with the progress of technology, its foundation trends to become larger. Especially in the case of long spanned bridges which is constructed on alluvium ground, large multi-cell box caissons are often adopted as their foundation. But the design method for such a large caisson has not been established so far and it used to be designed with excessive safety.

This paper describes the results of study projected to deal with this kind of problem which occurred on the way of designing the caisson foundation of HAMANA-OHHASHI Bridge.

**2. Caisson of HAMANA-OHHASHI Bridge**

HAMANA-OHHASHI Br. is a prestressed concrete girder bridge with four lanes on two separate girders. It has five spans and its full length is 631.8 m. Its center span is formed by 120m + 120m cantilevers and as a concrete girder bridge it will be the longest span in the world.

The foundation of the main pier which supports this superstructure is based on alluvium ground. On this foundation 27,000 ton of vertical load always acts and during the earthquake considered in design, moreover 181,000 ton-m of longitudinal moment load caused by horizontal force along to bridge axis, or 188,000 ton-m of transverse moment load caused by transverse force, acts. Therefore, a big reinforced concrete caisson with cells as is shown in Fig. 1 was planned for the foundation of the bridge.

However, neither the necessary and sufficient amount of reinforcing steel bar in the top slab or bulkheads could be estimated nor the sufficiency in thickness of the bulkheads could be confirmed. This is because the behavior of slab, the bearing stress in bulkheads, the stress concentration near the corner, the

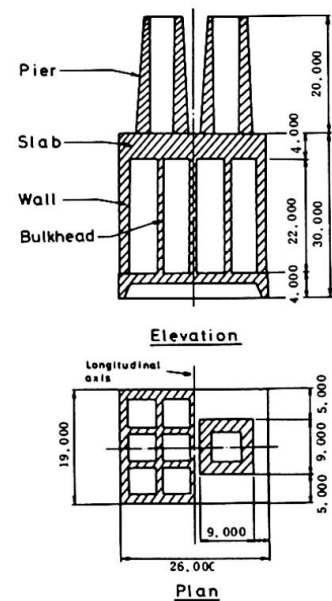

**Fig. 1 Caisson of HAMANA-OHHASHI Bridge**

state how the load which is carried through the piers on the slab spreads in the caisson, were not clear.

To solve these problems and to design the caisson rationally, two kinds of model tests were performed. Their results were applied into an actual design.

In this study, furthermore, analytical methods which will be easily applied in designing such a kind of structures were examined.

### 3. Model Tests

Strictly speaking, tests must be performed on the models which behave nonlinearly, considering that caisson is made of reinforced concrete. But actually this is so difficult that stress was obtained through elastic tests and caisson was designed according to allowable stress method.

Experimental tests are composed of loading test on an acrylic model and three-dimensional photo-elasticity test. Scale factors of these models are 1/50, 3/400 respectively.

#### 1) Loading Test on an Acrylic Model

The material of model is acrylic resin, not only because it can be processed without difficulty but also it has low Young's modulus ( $E=29,000 \text{ kg/cm}^2$ ) which leads to larger strain with small loads. This model was made by assembling acrylic plates which were installed with strain-gages. Most of them were affixed to 1/4 part of the model, considering the symmetry of the caisson.

Loads were vertical load, longitudinal moment load and transverse moment load. They were controlled by hydraulic jacks or loading rods, and made to act step by step to confirm that the stress or strain is within the elastic region. Photo. 1 shows the view of experiment.

The strains detected by strain-gages were immediately digitalized into a paper tape and stresses were calculated by the computer off-line.

#### 2) Three-dimensional Photo-elasticity Test

By the acrylic model test the strains or stresses at discrete points on the surface can be obtained, but those at other parts or inside the caisson are unknown yet. This photo-elasticity test was made to treat these problems. In other words this test was performed in order to know the stress flow, the stress distribution inside the slab, stress concentration near the corner and to fill up the stress between those obtained by the acrylic model test.

The model was vertically loaded at 130 °C in the hearth and gradually cooled. Stress was obtained by examining the thin slices which were cut out of the model.

### 4. Experimental Results and Considerations

The stresses under the loading condition considered in design were calculated from the experimental results by applying the law of superposition and the law of similarity. Concerning these model tests, the law of similarity is written as the followings,

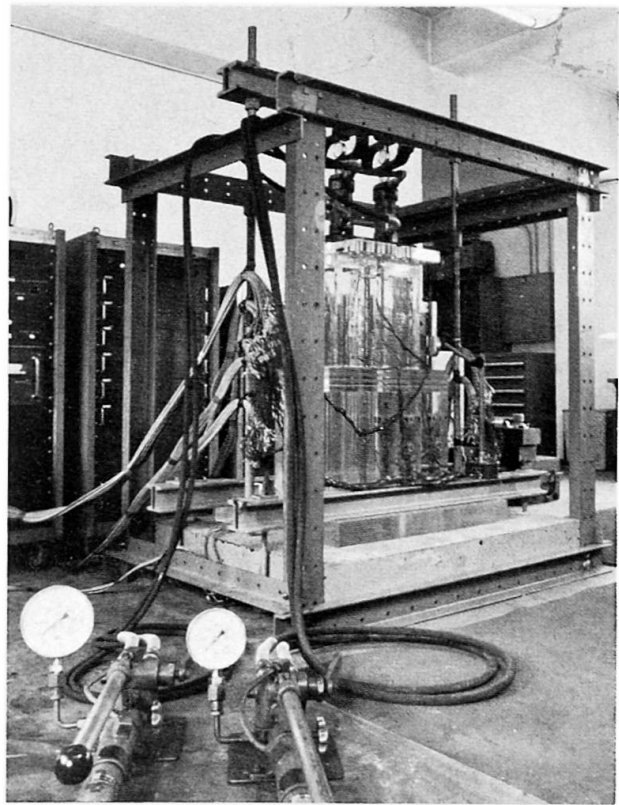

Photo. 1 View of Acrylic Model Test

for vertical load  $\frac{\sigma_m L_m^2}{P_m} = \frac{\sigma_p L_p^2}{P_p}, \nu_m = \nu_p$

for moment load  $\frac{\sigma_m L_m^3}{M_m} = \frac{\sigma_p L_p^3}{M_p}, \nu_m = \nu_p$

where  $\sigma, L, P, M, \nu$  indicate stress, representative length, vertical load, moment load and Poisson's ratio respectively, subscripts m, p also indicate model and prototype respectively.

About Poisson's ratio  $\nu$ , the law of similarity generally can't be satisfied in this kind of model tests. Because the Poisson's ratio of concrete  $\nu_p=0.17$ , though that of acryl is  $\nu_m=0.39$ . But in this study the influence of Poisson's ratio could be made clear by the numerical analysis as is mentioned later.

Fig. 2-(a) shows the distribution of horizontal stress at the bottom of slab and that of vertical stress at bulkheads and walls during longitudinal earthquake. Fig. 2-(b) shows those during transverse earthquake.

From these figures it is considered that some portion of the load, which comes through two piers, is carried to walls by the bending of slab, but the remains are directly transferred to bulkheads beneath the piers and carried toward walls by the shear force of bulkheads. This horizontal movement of stress occurs above the level of 2/3 of the height of caisson. Under this level the stress distribution is similar to that of a cantilever beam where the caisson is regarded as a cantilever rigidly embedded. This means that bulkheads must be designed strongly enough to resist shear force as well as bearing stress and the top slab must resist the bending moment,

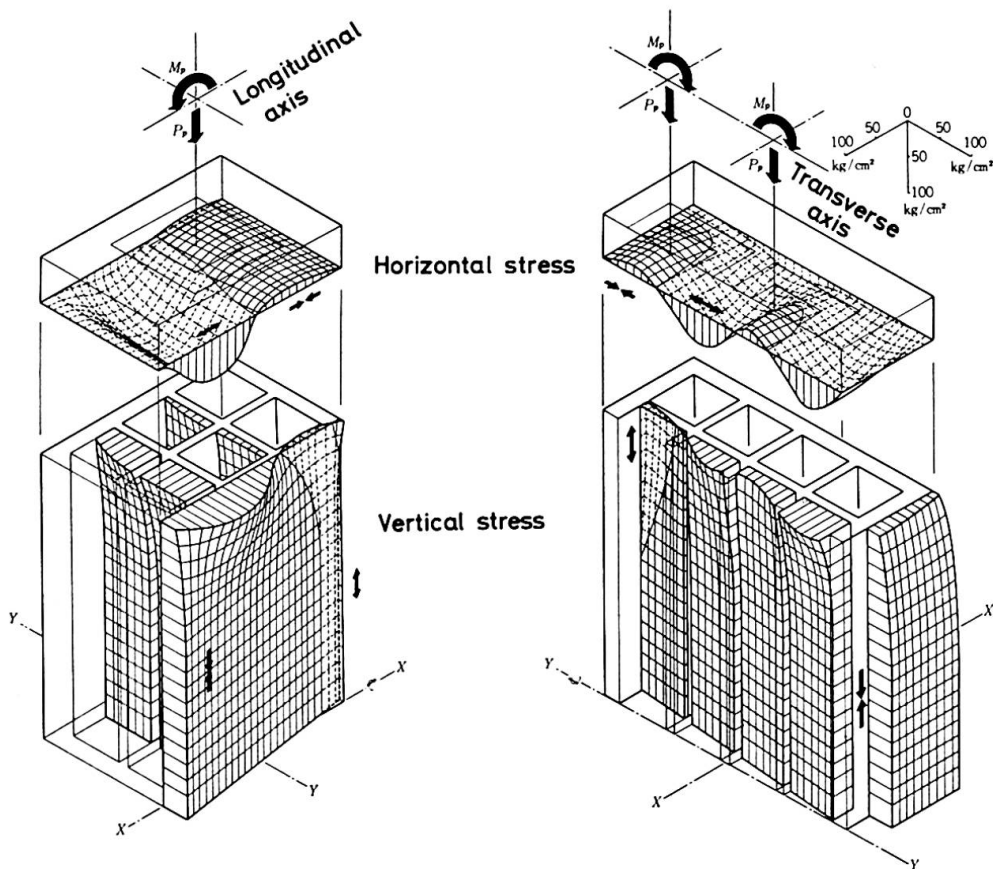

(a) Longitudinal Earthquake (b) Transverse Earthquake

Fig. 2 Stress Distribution During Earthquake

By the results of the three-dimensional photo-elasticity test, the stress distribution inside the slab was obtained as shown in Fig. 3. This figure indicates that the stress distribution inside the top slab is similar to what is acquired according to Bernoulli's hypothesis on the whole, though it has a little tendency as a deep beam. Therefore, it can be mentioned that the slab strongly has the property of a thin plate as far as the horizontal stress concerned.

Furthermore, Fig. 2 shows that the bulkheads located as a grid are not so stiff that the slab bends as one body. So it is more rational to design the slab as a plate on elastic supports i.e. bulkheads, rather than to design separately its each section, four sides of which are rigidly supported by the bulkheads or the walls of caisson.

The caisson of HAMANA-OHHASHI Br. was mainly designed to resist these stress distribution. And the corner between the pier and the slab was reinforced to resist the stress concentration that was made clear by the photo-elasticity test.

### 5. Numerical Analysis

The caisson of HAMANA-OHHASHI Br. was designed as mentioned above, in this study, numerical analyses were also conducted in order to find out a convenient analytical method that can be easily applied to the design of such a kind of structures.

If three-dimensional finite element method (i.e. F.E.M.) were able to be easily applied to solve these problems, it would be helpful for establishing reasonable design method. But, in general, three-dimensional F.E.M. analysis requires a great amount of computation, therefore, it cannot be considered convenient.

In this study, more convenient F.E.M. was applied to solve these problems, considering the behavior of each member of the caisson. It is the F.E.M. programmed to analyze shell structures which are fabricated with thin plates. In this analytical method, the wall of pier was divided into two plates located at the inner and outer surfaces of the wall in order to take the thickness of the wall of pier into the consideration.

The direct object of this analysis is the acrylic model used in the loading test, and Poisson's ratio  $\nu=0.39$ . The numerically analyzed stress distribution at the bottom of slab is shown by solid lines in Fig. 4, compared with experimental results which are shown by  $\text{---}o$  discretely, where the load is vertical.

It is easily pointed out from this figure that analytical result shows good agreement with the experimental one. This shows not only the propriety of this analytical method, but also the high precision of the experiments. Also in the case of moment load, the results of analytical study and experimental one are sufficiently coincide, though they are not shown in this paper. Hereafter this analytical method, which is often used to solve the problem of shell structure, can be successfully applied to this kind of structures.

Through numerical analysis the influence of the difference of Poisson's ratio was investigated, which cannot be examined by model tests. The dotted lines in Fig. 4 show the computed stress distribution when Poisson's ratio

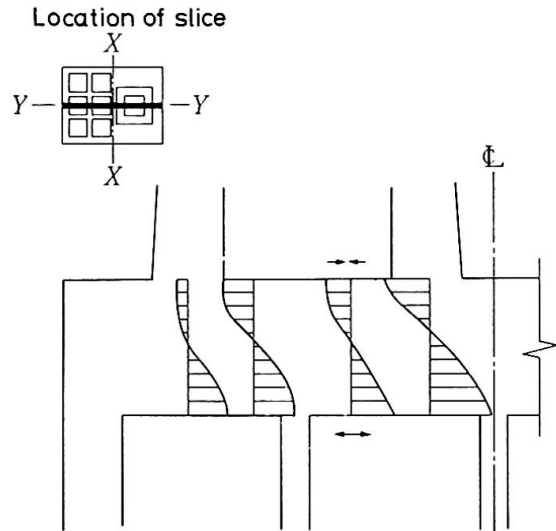

Fig. 3 Stress Distribution inside the Slab under Vertical Load

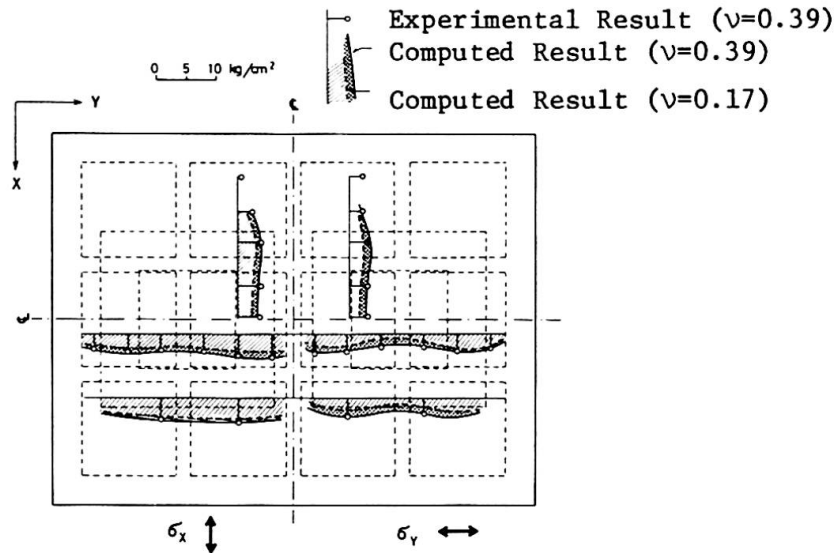

Fig. 4 Stress Distribution at the Bottom of Slab under Vertical Load of 1,000 ton

is equal to that of concrete ( $\nu=0.17$ ). This figure shows that the bending stress of the slab decreases 20% on the average while Poisson's ratio decreases from 0.39 to 0.17. The reason is thought that when Poisson's ratio decreases, the resisting force against shearing deformation in the bulkheads increases because of the increase in the shearing modulus  $G=E/2(1+\nu)$ , consequently the portion of load which the slab must carry to the walls decreases. Concerning the vertical bearing stress at the upper part of the bulkheads, it must increase when Poisson's ratio decreases. The difference, however, is little and able to be ignored. Because the bearing stress for  $\nu=0.39$  is so large in itself that its increase at  $\nu=0.17$  is relatively small. Therefore it may be concluded that in this type of caisson the bending stress in the top slab is considerably influenced, while the stress in bulkheads is influenced very little by the difference of Poisson's ratio.

Through the numerical analysis, it was also found that horizontal compression occurs in the lower part of pier and horizontal tension but not so strong occurs in the upper part of bulkheads in the case of vertical load. This shows that the piers and bulkheads act as stiffening ribs in regard to the bending of slab.

## 6. Conclusion

As mentioned above, this study was planned to solve the problems which occurred in designing the multi-cell box caisson of the HAMANA-OHHASHI Br. and two kinds of model tests and numerical analysis were performed to know the behavior of this caisson. The results of this study are summarized as the followings.

- 1) Though the top slab of caisson is very thick, it behaves as a thin plate and the stress distribution inside the slab yields to Bernoulli's hypothesis.
- 2) The load, which comes through the piers, is carried toward walls by the bending of top slab on the one side and also carried by the shear of the bulkheads on the other side.
- 3) Finite element method for shell structures was found to be conveniently applicable to this kind of structures. However, the thickness of the wall of pier must be considered in the analytical model as mentioned previously.



- 4) The decrease of Poisson's ratio results in the decrease in the bending stress of the slab. But the increase in the bearing stress of the bulkheads is little. These changes also mean that the shearing deformation in the bulkheads, upon which the Poisson's ratio has influence, contributes the distribution of load.

These results were applied to the design of HAMANA-OHHASHI Bridge. But, in order to design this type of caisson more rationally, the problem of optimum design and the problem of non-linear behavior should be investigated in future.

Finally the authors appreciate the contribution of Mr. C.Mimura, Mr. T. Fujita and Dr. Y.Morimitsu of Kajima Institute of Construction Technology.

#### BIBLIOGRAPHY

- 1) Langhaar, H.L. ; Dimensional Analysis and Theory of Models, John Willey & Sons, Inc.
- 2) Frocht, M.M. ; Photoelasticity, Vol. 1, Vol. 2, John Willey & Sons, Inc.
- 3) Zienkiewicz, O.C. ; The Finite Element Method in Engineering Science, McGraw-Hill

#### SUMMARY

In order to design multi-cell box caisson of HAMANA-OHHASHI Bridge, which is made of reinforced concrete, two kinds of model tests were performed. One is a loading test on an acrylic model and the other is a three-dimensional photo-elasticity test. Through these investigations the behaviour of the caisson was made clear. Furthermore, a finite element method which is conveniently applicable to this kind of structures, was proposed.

#### RESUME

Pour dimensionner les caissons multicellulaires en béton armé des fondations du pont, HAMANA-OHHASHI, nous avons fait deux essais: un modèle en acryl, et un essai de photo-élasticité. Ces recherches ont permis de déterminer le comportement du caisson. Nous avons enfin proposé une méthode des éléments finis applicables à ce genre de structures.

#### ZUSAMMENFASSUNG

Für die Bemessung der vielzelligen Senkkästen der HAMANA-OHHASHI Brücke wurden zwei Modellversuche durchgeführt. Der erste war ein Belastungsversuch an einem Acryl-Modell und der andere ein dreidimensionaler spannungsoptischer Versuch. Durch diese Untersuchungen wurde das Tragverhalten der Senkkästen geklärt. Vorgeschlagen wird weiter eine Methode auf der Basis Finiter Elemente, welche auf derartige Tragwerke leicht anwendbar ist.