

# On structural behaviour of hybrid I-beams

Autor(en): **Cywiski, Zbigniew**

Objektyp: **Article**

Zeitschrift: **IABSE congress report = Rapport du congrès AIPC = IVBH  
Kongressbericht**

Band (Jahr): **10 (1976)**

PDF erstellt am: **26.09.2024**

Persistenter Link: <https://doi.org/10.5169/seals-10551>

## **Nutzungsbedingungen**

Die ETH-Bibliothek ist Anbieterin der digitalisierten Zeitschriften. Sie besitzt keine Urheberrechte an den Inhalten der Zeitschriften. Die Rechte liegen in der Regel bei den Herausgebern.

Die auf der Plattform e-periodica veröffentlichten Dokumente stehen für nicht-kommerzielle Zwecke in Lehre und Forschung sowie für die private Nutzung frei zur Verfügung. Einzelne Dateien oder Ausdrucke aus diesem Angebot können zusammen mit diesen Nutzungsbedingungen und den korrekten Herkunftsbezeichnungen weitergegeben werden.

Das Veröffentlichen von Bildern in Print- und Online-Publikationen ist nur mit vorheriger Genehmigung der Rechteinhaber erlaubt. Die systematische Speicherung von Teilen des elektronischen Angebots auf anderen Servern bedarf ebenfalls des schriftlichen Einverständnisses der Rechteinhaber.

## **Haftungsausschluss**

Alle Angaben erfolgen ohne Gewähr für Vollständigkeit oder Richtigkeit. Es wird keine Haftung übernommen für Schäden durch die Verwendung von Informationen aus diesem Online-Angebot oder durch das Fehlen von Informationen. Dies gilt auch für Inhalte Dritter, die über dieses Angebot zugänglich sind.

### On Structural Behaviour of Hybrid I-Beams

Sur le comportement à la ruine des poutres en I hybrides

Zum Tragverhalten hybrider I-Balken

ZBIGNIEW CYWIŃSKI  
Assistant Professor  
Technical University of Gdańsk  
Gdańsk, Poland

This contribution refers to Theme Va of the Introductory and Preliminary Reports. It represents certain proposal for the plastic analysis of hybrid I-beams assuming combined action of bending and shear.

Author's treatment of mentioned problem bases upon that suggested by Strel'bitskaya for homogeneous beams /1/. Simultaneously Schilling's optimum design criteria are taken into account /2/. Collapse loads determined are compared with those resulting from the ASCE-AASHO regulations /3/.

Plastic bending-shear interaction analysis of homogeneous I-beams bases generally on the yield condition

$$\sigma^2 + 3\tau^2 = \sigma_0^2, \quad (1)$$

where  $\sigma$ ,  $\tau$  are the elastic bending and shear stresses, respectively, and  $\sigma_0$  is the yield stress. According to /1/ the elastic stress patterns are as shown in Fig. 1; both of them are more ( $\sigma$ ) or less ( $\tau$ ) inaccurate but fulfil the yield condition (1) at each point of the I-section and develop sufficiently exact (conservative) collapse load values. Similar analysis of hybrid I-beams can be based on stress patterns as given in Fig. 2.

With the specifications of Fig. 2 the fully plastic moment and shear,  $M_0$  and  $Q_0$  respectively, can be expressed as follows:

$$M_0 = \sigma_0 \frac{Afh}{2} + \alpha \sigma_0 \frac{th^2}{4} = \sigma_0 \frac{th^2}{4} (1+\alpha), \quad (2)$$

$$Q_0 = \alpha \sigma_0 th = \sigma_0 \frac{th}{\sqrt{3}} \alpha, \quad (3)$$

whereby the following numerical values of  $\alpha$  and  $\sigma_0$  are being considered:

- $\alpha = 1.00$ , for  $\sigma_0 = 36,000$  psi (homogeneous beam),
- $\alpha = 0.72$ , for  $\sigma_0 = 50,000$  psi
- $\alpha = 0.36$ , for  $\sigma_0 = 100,000$  psi (hybrid beams).

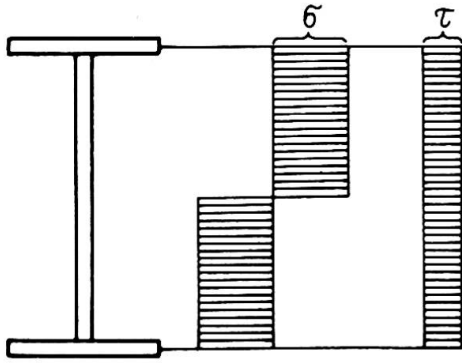

Fig. 1. Elastic stress patterns for homogeneous I-beam; assumed in [1]

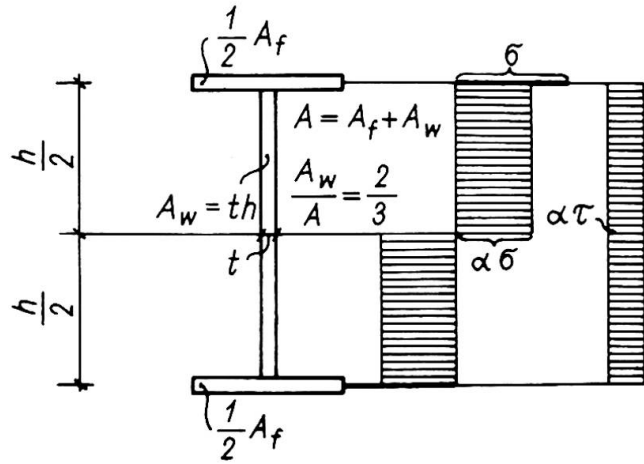

Fig. 2. Elastic stress patterns for hybrid I-beam; Author's assumption

Investigations performed concern in particular the beam fixed at both ends carrying single load  $P$  at span-mid or uniform load  $q$  all over the span (Fig. 3).

According to Author

$$P = \frac{8 \frac{M_o}{l}}{\sqrt{\frac{16 M_o^2}{l^2 Q_o^2} + 1}} = \frac{8 \frac{M_{ou}}{l}}{\sqrt{12 \left(\frac{h}{l}\right)^2 + \left(\frac{2\alpha}{1+\alpha}\right)^2}}$$

$$q = \frac{16 \frac{M_o}{l^2}}{\frac{16 M_o^2}{l^2 Q_o^2} + 1} = \frac{16 \frac{M_{qu}}{l^2}}{6 \left(\frac{h}{l}\right)^2 \frac{1+\alpha}{\alpha} + \frac{2\alpha}{1+\alpha}}$$

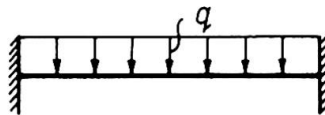
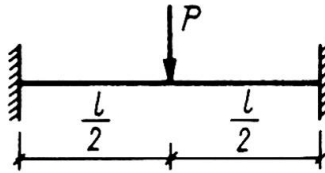

According to ASCE-AASHO

$$P = \frac{16 \frac{M_o}{l}}{\sqrt{\frac{64 M_o^2}{l^2 Q_o^2} \frac{\alpha}{1+\alpha} + 1 + 1}} = \frac{8 \frac{1+\alpha}{\alpha} \frac{M_{ou}}{l}}{\sqrt{12 \left(\frac{h}{l}\right)^2 \frac{1+\alpha}{\alpha} + 1 + 1}}$$

$$q = \frac{32 \frac{M_o}{l^2}}{\sqrt{\frac{128 M_o^2}{l^2 Q_o^2} \frac{\alpha}{1+\alpha} + 1 + 1}} = \frac{16 \frac{1+\alpha}{\alpha} \frac{M_{qu}}{l^2}}{\sqrt{24 \left(\frac{h}{l}\right)^2 \frac{1+\alpha}{\alpha} + 1 + 1}}$$

Fig. 3. General expressions of collapse loads

Extending the interaction formula of /1/

$$\frac{M^2}{M_o^2} + \frac{Q^2}{Q_o^2} = 1 \tag{4}$$

over to hybrid I-beams and taking into account the corresponding equation

$$\frac{M}{M_o} + \frac{Q^2}{Q_o^2} \frac{\alpha}{1+\alpha} = 1$$

resulting from ASCE-AASHO regulations /3/ a set of general collapse load expressions can be obtained which is given in Fig. 3;

therein

$$M_o = \frac{1+\alpha}{2\alpha} M_{ou} \tag{5}$$

where  $M_{ou} \equiv M_o (\alpha=1)$  holds for homogeneous (uniform) beam.

On the basis of the expressions derived the corresponding interaction curves, in terms of  $Pl/M_{ou}$  and  $ql^2/M_{ou}$  respectively, as functions of the span-depth ratio  $l/h$  can be found; this is illustrated in Fig. 4 and Fig. 5.

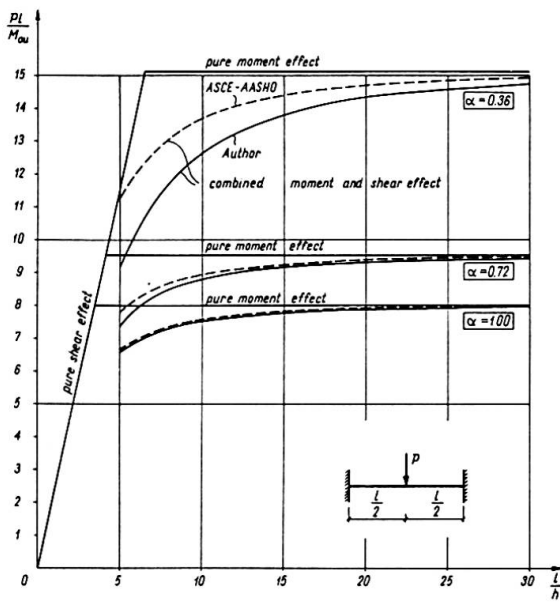

Fig 4 Collapse loads - concentrated

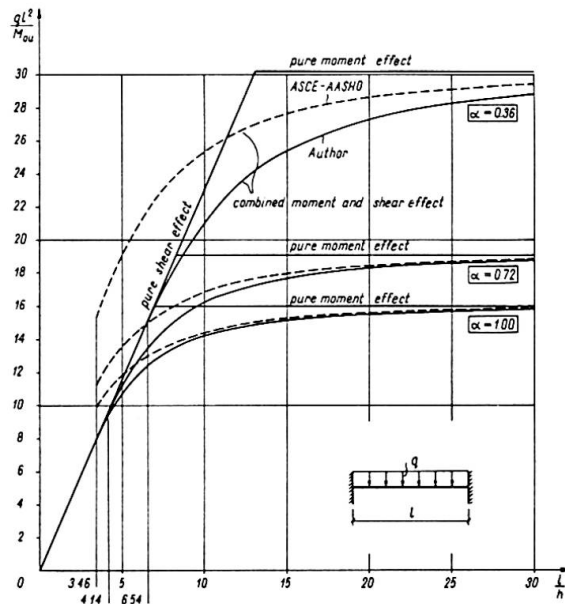

Fig 5 Collapse loads - uniform

In conclusion Author's proposal can be characterized as follows:

1. It yields collapse loads close (conservative) to those of the ASCE-AASHO regulations whereby the relative difference increases with a decrease of the  $l/h$ -ratio and the  $\alpha$ -value.
2. It visualizes clearly the dominating effect of pure shear for small  $l/h$ -ratios.
3. It can be found handy analysing non-uniform plastic torsion problems (bimoment - flexural-torsional moment interaction, St.-Venant torsional moment effect) of hybrid sections, as shown for the homogeneous ones in /1/ and /4/.

#### References

- /1/ Strel'bitskaya, A.I.: A study of strength of thin-walled beams beyond the elastic limit (in Russian). Izdatel'stvo AN USSR, Kiev 1958.
- /2/ Schilling, Ch.G.: Optimum properties for I-shaped beams. Journal of the structural Division, ASCE, Vol. 100, No. ST 12, Dec. 1974, pp. 2385-2401.
- /3/ Design of hybrid steel beams. Report of the Subcommittee 1 on Hybrid Beams and Girders of the Joint ASCE-AASHO Committee on Flexural Members. Journal of the Structural Division, ASCE, Vol. 94, No. ST 6, June 1968, pp. 1397-1426.
- /4/ Strel'bitskaya, A.I.: Limit state of frames out of thin-walled members in bending with torsion (in Russian). Izdatel'stvo AN USSR, Kiev 1964.

#### SUMMARY

Simplified procedure is used to determine the ultimate load of hybrid I-beams in combined bending with shear. It has been found sufficiently exact and is recommended for analysis of similar problems within the theory of non-uniform torsion.

#### RESUME

Pour la détermination de la charge ultime de poutres hybrides en I soumises à la flexion et au cisaillement, on applique une méthode simplifiée. Celle-ci a donné des résultats suffisamment précis et est recommandée pour la résolution des problèmes similaires dans la théorie de torsion non uniforme.

#### ZUSAMMENFASSUNG

Ein vereinfachtes Verfahren wurde benutzt, um die Traglast hybrider I-Balken bei zusammengesetzter Biegung mit Schub zu bestimmen. Dieses wurde ausreichend genau gefunden und wird zur Behandlung benachbarter Probleme innerhalb der Theorie der Wölbkrafttorsion empfohlen.