

Semi-rigid joints in composite frames

Autor(en): **Johnson, R.P. / Hope-Gill, M.**

Objektyp: **Article**

Zeitschrift: **IABSE congress report = Rapport du congrès AIPC = IVBH
Kongressbericht**

Band (Jahr): **9 (1972)**

PDF erstellt am: **24.09.2024**

Persistenter Link: <https://doi.org/10.5169/seals-9551>

Nutzungsbedingungen

Die ETH-Bibliothek ist Anbieterin der digitalisierten Zeitschriften. Sie besitzt keine Urheberrechte an den Inhalten der Zeitschriften. Die Rechte liegen in der Regel bei den Herausgebern.

Die auf der Plattform e-periodica veröffentlichten Dokumente stehen für nicht-kommerzielle Zwecke in Lehre und Forschung sowie für die private Nutzung frei zur Verfügung. Einzelne Dateien oder Ausdrucke aus diesem Angebot können zusammen mit diesen Nutzungsbedingungen und den korrekten Herkunftsbezeichnungen weitergegeben werden.

Das Veröffentlichen von Bildern in Print- und Online-Publikationen ist nur mit vorheriger Genehmigung der Rechteinhaber erlaubt. Die systematische Speicherung von Teilen des elektronischen Angebots auf anderen Servern bedarf ebenfalls des schriftlichen Einverständnisses der Rechteinhaber.

Haftungsausschluss

Alle Angaben erfolgen ohne Gewähr für Vollständigkeit oder Richtigkeit. Es wird keine Haftung übernommen für Schäden durch die Verwendung von Informationen aus diesem Online-Angebot oder durch das Fehlen von Informationen. Dies gilt auch für Inhalte Dritter, die über dieses Angebot zugänglich sind.

Semi-Rigid Joints in Composite Frames

Jointes semi-rigides dans les constructions en portique composées

Halbstarre Verbindungen in Verbund-Rahmen

R.P. JOHNSON

University of Warwick, Coventry, England

M. HOPE-GILL

University of Cambridge, England

Introduction

When composite beams are used in buildings, they often form part of a framed structure, the behaviour of which is influenced by the detailing of the beam-column joints. In no-sway frames, beam-column interaction can safely be neglected in the design of beams, if these are assumed to be simply-supported; but the corresponding assumption that loads are transferred to the columns at small eccentricities may be unsafe for column design, if floor slabs are continuous or if beam-column joints have appreciable rigidity. The column moments are likely to be under-estimated, particularly when the beams have unequal spans or loadings. Experience has shown that premature failure of columns designed by the existing 'simple' method does not occur in non-composite frames; but its implications for the design of columns in composite frames and at lower load factors remain unexplored.

Extensive research on composite beams continuous over simple supports^(1,2) has shown that simple plastic theory gives reliable values for moments of resistance in both positive and negative bending and for the collapse load of a continuous beam, provided that premature buckling is avoided and that secondary failures are prevented by correct detailing.

The behaviour of individual lengths of composite columns has also received much attention, and a design method is available⁽³⁾. But little work on beam-column interaction in rigid jointed frames has been reported, apart from a study of the transfer of wind moments in sway frames from composite beams to steel columns⁽⁴⁾.

Possible design methods for composite frames are now discussed. It is shown that neither 'simple' nor 'rigid' beam-column joints are ideal. An account is given of tests on a new type of semi-rigid joint, first proposed by Barnard⁽⁵⁾, which combines some of the best features of the other types of joint.

Design of composite frames

We consider a no-sway multi-storey frame with uncased beams, composite for positive moments, and steel or composite columns. It is assumed that design is

governed by the limit states of Collapse and Unserviceability. Ultimate-strength analysis is appropriate at the Collapse limit state. Local damage or vibration may have to be considered at the Unserviceability limit state, but the usual design criterion is excessive deflection. Yield of steel at service loads need not be avoided for its own sake; it has long been accepted in joints and in light crack-control reinforcement in slabs.

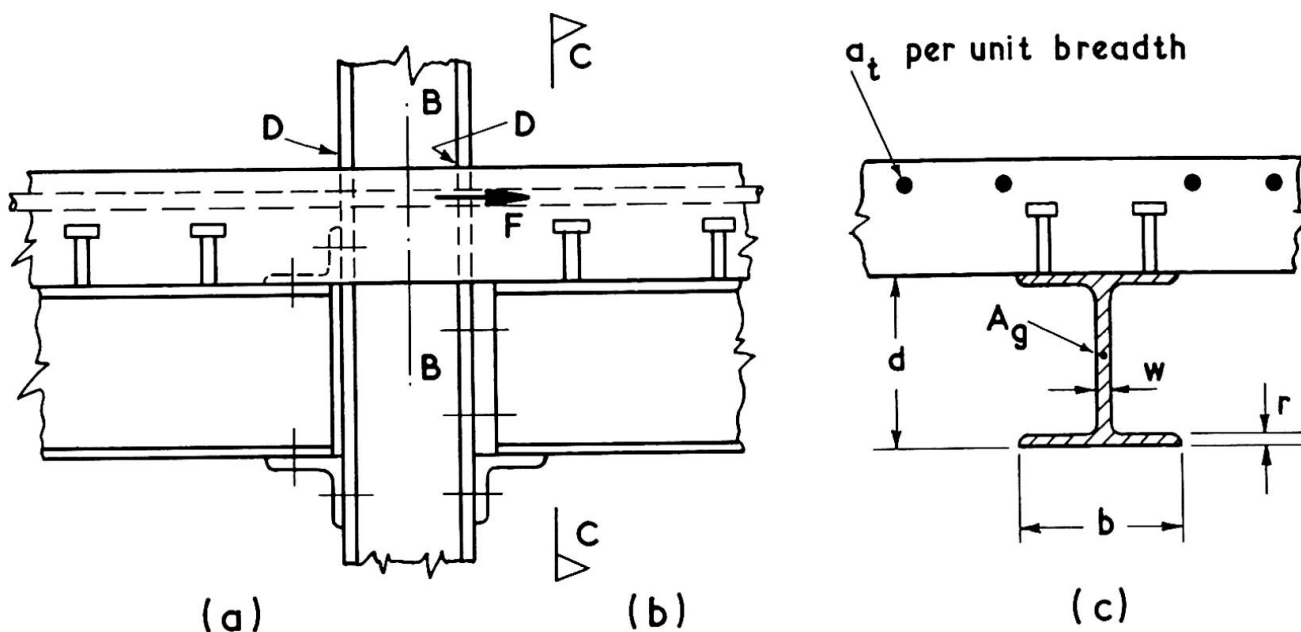

Fig. 1 Typical bolted joints between composite beam and steel stanchion

'Simple' design. This implies discontinuity of slope between two beams supported on an internal column, and that the moment transferred to the column is small, even when the beams are at flexural failure. If conventional black-bolted joints of the type shown in Figs. 1(a) and (b) are used, then bolt slip and deformation of the thin angles in (a) or end plate in (b) will ensure that end moments are small, provided that the concrete slab is jointed or unreinforced across line B-B. 'Simple' design of columns by the established methods is then acceptable.

However, if a two-way floor system is used, reinforcement crossing B-B is essential, as this is the plane of maximum longitudinal shear in a beam framing into the minor axis of the column. Even in a one-way system, crack-control reinforcement (dashed line in Fig. 1) is often preferable to a joint in the slab.

The beams, being designed as simply-supported, have shear connectors throughout their length. The crack-control reinforcement over a certain breadth of slab therefore acts compositely with the joist. If F (Fig. 1) is the resultant tensile force in the slab at the collapse limit state, the effective breadth B_e may be defined by

$$F = a_t B_e f_r \quad (1)$$

where a_t is the area of reinforcement per unit width of slab, and f_r is its yield stress. The force F depends on the balance between several conflicting factors. It is increased by strain-hardening in the highly-strained reinforcement adjacent to the column, and by tensile stress in any uncracked concrete. It is reduced by loss of interaction due to slip at the shear connectors, and also by shear lag in the plane of the slab. The bending moment that can be transferred to the column is also difficult to predict. When both beams are at flexural failure, cracking of the slab will ensure that little, if any, of the force F is transferred to the column by compression on the faces D (Fig. 1). But the 'worst case' for the column is likely to be when one of the beams is unloaded. The force F will be balanced by an equal compressive force in the bottom flange of the loaded beam, giving a bending moment Fkd (Fig. 2), a large proportion of which may be resisted by the column, particularly if the beams are of unequal depth.

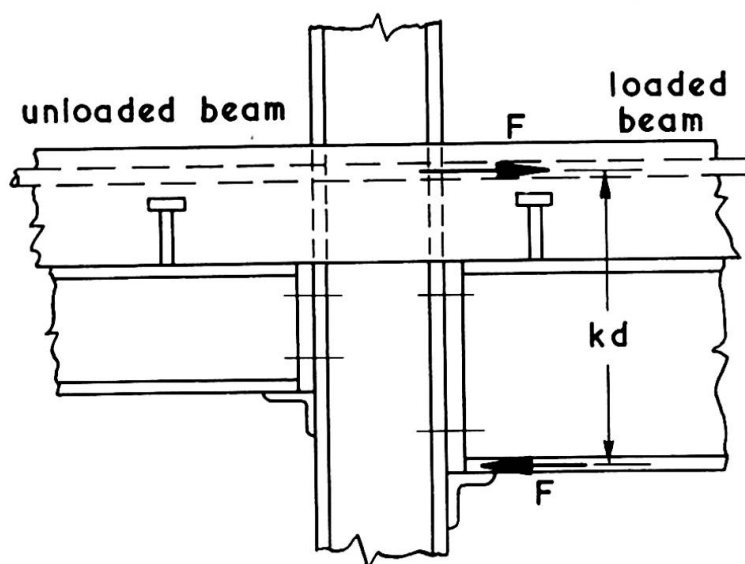

Fig. 2 Beams of unequal depth

If B_e in Eq. (1) is taken as equal to the effective breadth at midspan of the beam in question, it is found that in composite beams having relatively thick slabs, the moment Fkd could be as great as the plastic moment of resistance of the steel joist. It is obviously uneconomic to proportion all columns to resist moments of this magnitude, and yet to take no account of them in designing the beams. A possible solution is to limit the stiffness of the beam-column joints that may be used and the amount of crack-control reinforcement that may be placed in the slab, when 'simple' design is used for the beams, and to take account of these limits when specifying the eccentricities at which the load is assumed to be applied to the columns.

'Rigid' design. Another alternative is to make beam-column joints rigid, by welding or friction-grip bolting, to design the beams as continuous, using simple plastic theory, and to determine the moments in columns by analysis of a limited

frame, as recommended in a recent report (6) on the design of steel frames. This method only works well at the collapse limit state for beams having joists of compact cross-section, and may not give the most economical structure, as rigid joints are expensive, both in materials and in labour.

There is also a problem at the unserviceability limit state. The positive moment of resistance of a symmetrical I-section composite with a concrete slab is much greater than that of the joist alone. Thus the distribution of strength in a fixed-ended beam under uniform load (taken as a simple example) differs greatly from the distribution of moments at working load given by elastic analysis, even if allowance is made for the reduction of flexural rigidity due to cracking of the slab (Fig. 3). When this is not done (as is likely in practice), the disparity is worse. Thus if the present British limit of $0.9f_y$ for working-load stress in steel in composite beams is applied to continuous beams of uniform section, it will almost always govern design, and make it impossible to take full advantage of the large positive moment of resistance available at midspan. The problem is partly apparent, due to neglect in the elastic analysis of the redistribution of moment due to cracking of concrete, and partly real, for more accurate analysis of a particular composite frame showed (7) that yield would indeed occur at working load in regions of negative moment. This increases deflexions by an amount that is difficult to calculate, and should be avoided in practice for this reason.

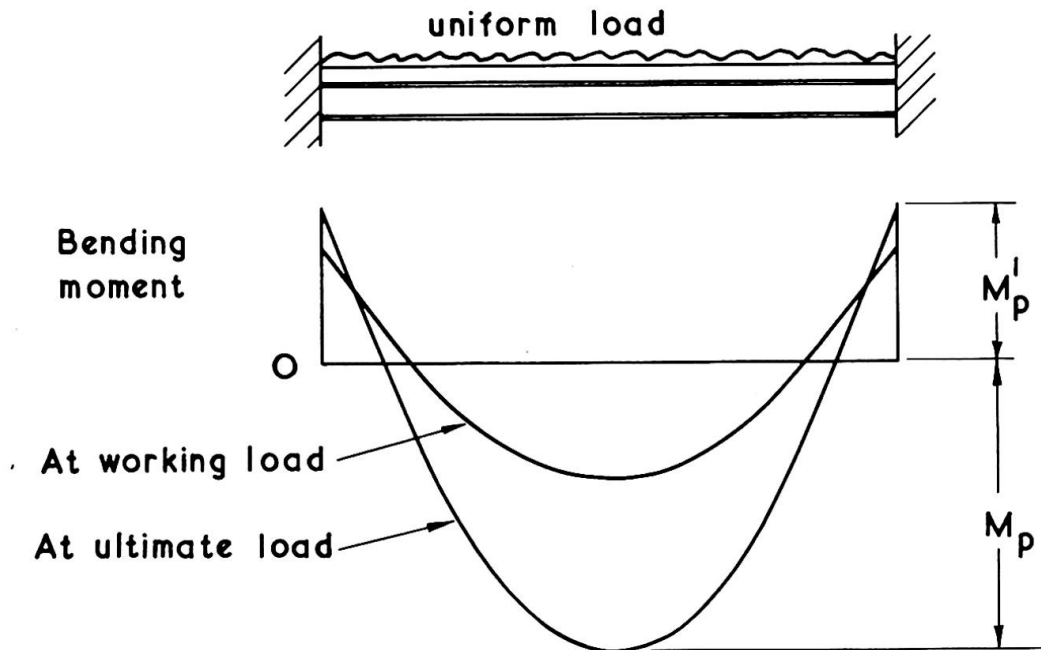

Fig. 3 Bending-moment distributions in a fixed-ended beam

The problem arises from the disparity between M_p and M_p^i (Fig. 3) and can be mitigated, if not solved, by placing more top longitudinal reinforcement in the slab, and so increasing M_p^i . But there is a limit to this process. At flexural failure, the joist must resist at cross-section C-C (Fig. 1b) a net compressive force F in addition to the vertical shear, and undergo without loss of strength

through buckling sufficient rotation to develop the midspan hinge moment. But the limiting web depth-thickness ratio of joists having adequate rotation capacity for this purpose falls as F increases (8), so that this design method is attractive only for the more compact rolled sections.

Semi-rigid joints

It has been shown that 'simple' design may be uneconomical because no use can be made in the beams of the end moments that may be developed by composite action of slab reinforcement in the negative moment region. If rigid joints are used, negative moment regions have inadequate rotation capacity unless joist cross-sections are compact, and reach yield at a load which is too low a proportion of the plastic collapse load for the beam as a whole. In brief, 'simple' joints are too unpredictable; 'rigid' joints are often too stiff in relation to their strength, and are expensive.

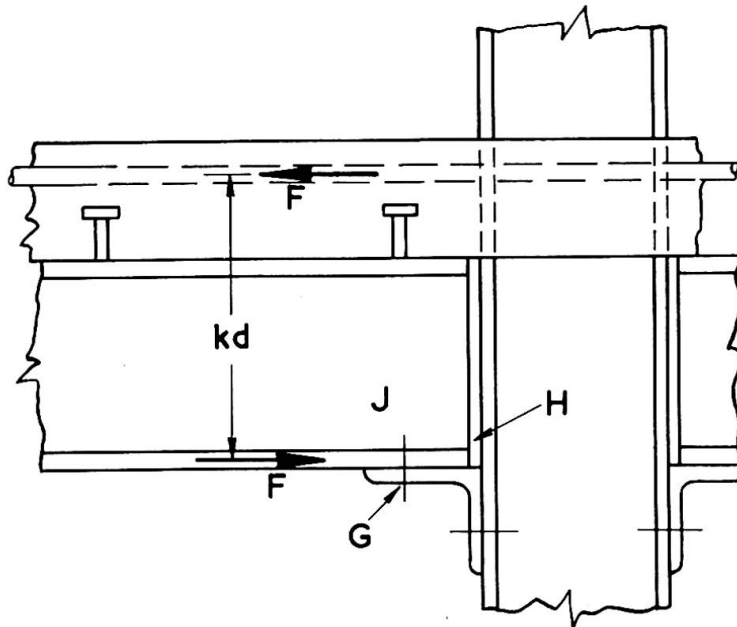

Fig. 4 A semi-rigid joint

Thus there is a need for a semi-rigid joint with a large rotation capacity and a predictable flexural strength, that does not require site welding or accurate fitting. These requirements are met by the joint shown in Fig. 4. It differs from that of Fig. 1(a) in three ways:

(i) The reinforcement A_t is heavier than the minimum required for crack control, and is placed close to the column, so that the force F may be taken as $A_t f_r$.

(ii) Friction-grip bolts are used in the joint at G, which has an ultimate strength in longitudinal compression not less than $A_t f_r$.

(iii) The beam is designed as continuous, using simple plastic theory, with M_p' taken as $A_t f_r k d$. Shear connectors are provided to transfer the force F from the

slab to the joist, using a method (9) derived from research on negative moment regions.

Research on such joints at Cambridge University began in 1969. The success of the first test led to a more comprehensive study, and four more specimens have been tested. In order to expose any limitations of the joint, web cleats and top brackets were omitted, even though they may be provided in practice, and quite large forces F were used. A non-dimensional measure of F is the Force Ratio, Φ , given by

$$\Phi = A_t f_r / A_g f_y \quad (2)$$

where A_g and f_y refer to the whole cross-section of the rolled steel section. So far, force ratios from 0.16 to 0.44 have been used.

The suitability of a joint for plastic design is best indicated by its moment-rotation ($M-\theta$) curve. The available rotation at maximum moment must be sufficient for a midspan hinge to develop when the specimen forms part of a continuous beam. Cost may be reduced if the design does not require a tight fit between joist and column at H (Fig. 4). Any slip of the bolts at C closes the gap at H and increases the rotation capacity of the joint; so the ultimate-strength behaviour may be improved if there is a gap.

The joint at G must be designed not to slip at working load. This may be done by using black bolts at G and packing at H, or friction-grip bolts at G. In the present work, friction-grip bolts were used, and a gap was left at H so that the load at bolt slip could be determined. At the larger forces F , the joint detail becomes clumsy if the bolts are loaded in single shear, so the double-angle detail shown in Fig. 5 was evolved. This and the use of a web stiffener in the column eliminates local bending of the column flange at this point. The relatively long angles required in a joint of this type help to stabilize the bottom flange of the joist. Moment gradient is so high in this region that the help is significant.

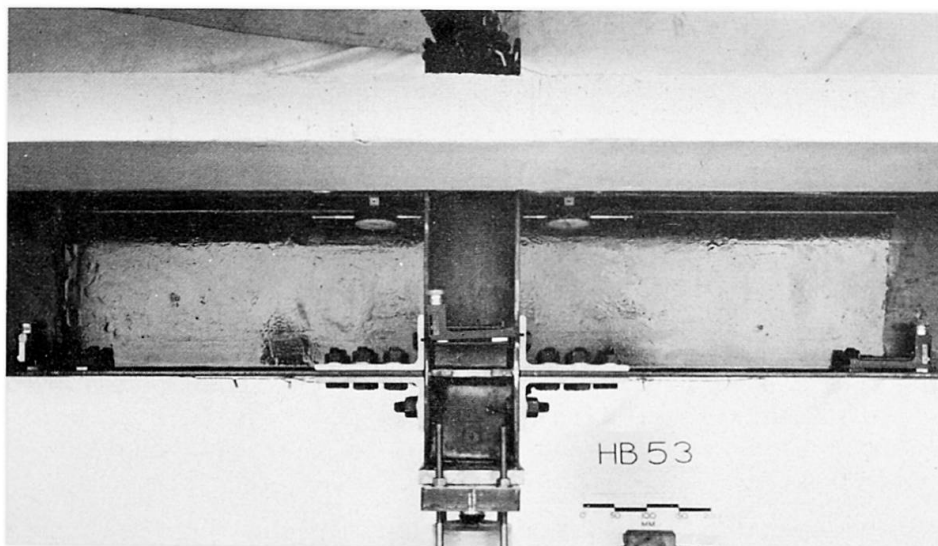

Fig. 5 The joint in specimen HB 53

The bolts through the column flange are designed for the whole of the vertical shear in the usual way. Friction-grip bolts were used in the test specimens, but black bolts should be equally suitable.

The results of the tests

The test specimens were numbered HB 50 to 54. Each consisted of a stub column connected by semi-rigid joints to short lengths of composite beam, which simulated the negative moment region of a continuous beam. Equal point loads were applied to the free ends of these beams (Fig. 5) and were increased in steps until failure occurred. Each test extended over two or three days. The bending moment at the face of the column, M , was calculated for each load stage. The results are given as curves of M/M'_p against the rotation, θ , in Figs. 6 and 7.

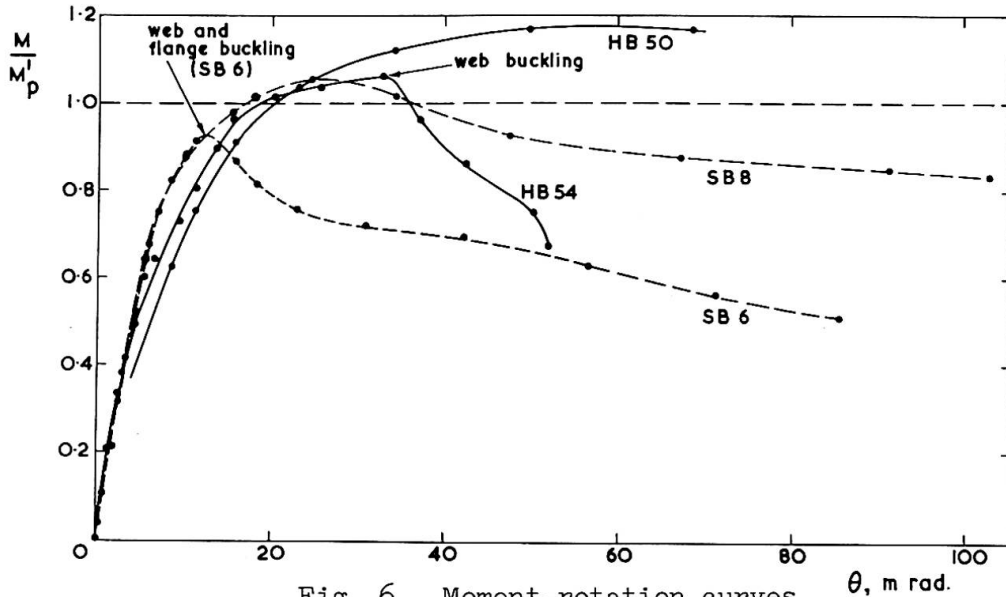

Fig. 6 Moment-rotation curves

The five specimens fall into three groups, according to the size of the steel joist. The Figures also give curves for the three rigid-jointed beams, tested by Climenhaga (8), that are most similar to the specimens of these groups. All three were continuous over their central support, and were heavily stiffened there to provide a rigid column-like support region. A composite concrete slab was provided in HB 41, as in the present tests, but in SB 6 and SB 8 the slab and its reinforcement were simulated by welding a plate to the top flange of the joist. Climenhaga's beams buckled on one side of the column, but not on the other. Buckling also occurred in HB 54, and slab failure in HB 53. The rotations given for these five specimens are therefore those of the free end on the side that failed, relative to the centre-line of the column. Results for beams HB 50 to 52 are averages of the rotations of the two beam lengths.

Table 1 gives the following data for these eight specimens: the joist dimensions b and d and the web and flange slendernesses (with notation as in Fig. 1(c)), and values of A_g , f_y , Φ and M'_p , as defined earlier.

The load at which slip first occurred in the bolted joints, W_s , is given by the ratio W_s/W_p , where W_p is the load at which the bending moment at the face of the columns is M'_p .

The flexibility of the joint at working load is indicated by θ/θ_e , where θ is the observed mean rotation when the bending moment at the column face is $0.5 M'_p$, and θ_e is the mean rotation calculated by full-interaction elastic theory for the composite cross-section, assumed continuous over the whole length of the test specimen, and neglecting the stiffness of concrete in tension.

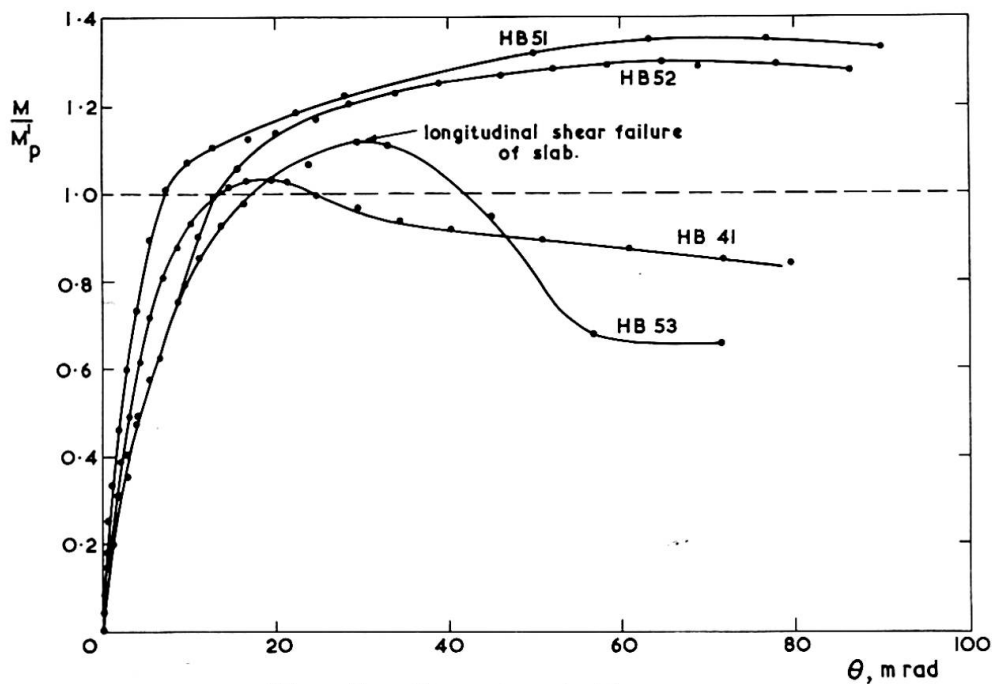

Fig. 7 Moment-rotation curves

Discussion

It has been found (8) that the parameters that most influence the rotation capacity of negative moment regions having rigid beam-column joints are the yield strength and web and flange slendernesses of the steel joist and the Force Ratio of the composite cross-section. The flange slendernesses (b/r) of seven of the sections considered here lay between 16.4 and 17.1; that of the eighth (HB 41) was 15.2. The rotation capacity of the three rigid-jointed beams was influenced by flange buckling, and none of the eight sections would normally be considered as suitable for use in plastic design. But in the beams with semi-rigid joints, little flange buckling occurred, due to the restraint provided by the angles used for the bolted joints.

The other three parameters all appear in the rule given in the current A.I.S.C. Specification for the limiting web slenderness of sections that can be used in plastic design. Climenhaga has concluded (8) that the rule should be applicable to rigid-jointed composite beams in the form:

$$\left. \begin{aligned} (d - 2r)/w &\leq 2.44(1 - 1.4\Phi)/\sqrt{\epsilon_0} & \text{for } 0 \leq \Phi \leq 0.28, \\ (d - 2r)/w &\leq 1.48/\sqrt{\epsilon_0} & \text{for } \Phi > 0.28 \end{aligned} \right\} \quad (3)$$

where ϵ_0 is the elastic strain of the steel at its yield stress. The ratio of the measured web slenderness of each beam to the limiting slenderness as given by Eq. (3) is given in Table 1 under the heading 'Web ratio'. Five of the eight beams were 'slender' as here defined; the others are described as 'compact'.

The Authors' study of rotation requirements in continuous composite beams is not yet complete; but it is known that a necessary condition for the applicability of simple plastic design is that the maximum negative moment reached in a test must exceed M'_p and that an important parameter is the 'available rotation', θ_a , defined as the maximum rotation at which $M/M'_p \geq 1.0$.

The results of the three groups of tests are now discussed in turn. The joists in specimens HB 50 and SB 8 were of the same 'compact' cross-section, and the force ratios were similar. Buckling of the rigid-jointed beam, SB 8, limited θ to 37 mrad (radians $\times 10^{-3}$). The test on HB 50 was terminated by failure of the shear connectors at 68 mrad. The mean load per connector at M'_p was 75 per cent of the push-out strength. If '64 per cent' design had been used, as now recommended (9), the available rotation would have been even greater.

Some reduction in available rotation with increasing force ratio is indicated by the curves for specimens HB 51, 52, and 53 (Fig. 7). The tests on HB 51 and 52 were terminated at large rotations by failures of the shear connection in HB 51 and limitations of the test rig in HB 52. The transverse reinforcement in the slab of HB 53 was designed by a proposed ultimate-strength method (10) to be just sufficient at a bending moment of M'_p . Longitudinal shear failure occurred at 1.11 M'_p , and is the reason for the steep falling branch of the curve for this beam.

It does not follow from these failures in cantilever specimens that the shear connectors and transverse reinforcement in continuous composite beams will be inadequate if designed for shear flows calculated from simple plastic theory. The compatibility requirements in such beams are sometimes such that negative moments of resistance ten or twenty per cent above M'_p are reached (due to strain-hardening) at the design ultimate load. But the coexisting positive moments are less than M_p , and the total shear flow between locations of hogging and sagging hinges is similar to that given by the simple theory; whereas in a cantilever it is roughly proportional to the negative moment of resistance.

The web ratio of the rigid-jointed beam HB 41 was similar to those of HB 52 and 53, but it had a lower ultimate strength and a much lower available rotation. Plastic design could not be used for this beam, if Eq. (3) is followed. It is likely that it could be used for the three beams with semi-rigid joints, if the secondary failures were prevented.

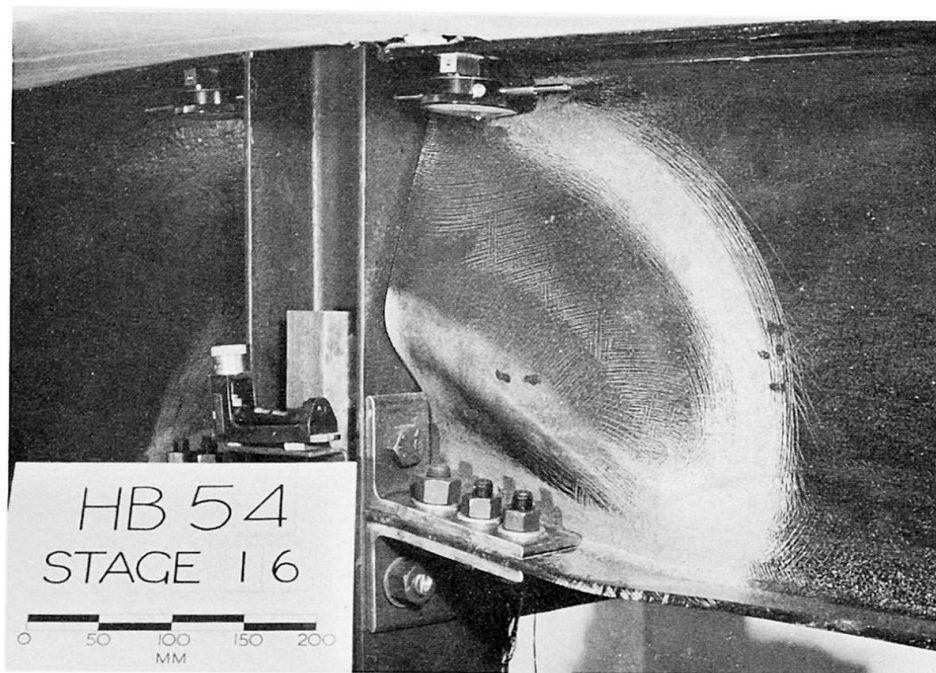

Fig. 8 Web buckling in specimen HB 54

The last comparison is between beams HB 54 and SB 6, both of which had very slender webs. Severe web and flange buckling occurred in the rigid-jointed beam, which failed at a maximum moment of $0.92M_p'$. In beam HB 54, buckling in vertical compression occurred at the free edge of the web at $1.06 M_p'$, as shown in Fig. 8, and led to a local failure of the slab above. This mode of failure could easily be prevented by the use of a bolted web cleat, which would in any event be required to stabilize so slender a beam prior to the casting of the slab. These results show that even in a very slender beam, the semi-rigid joint gives a greater relative strength and available rotation than does a rigid joint. It is not suggested that either beam, without stiffening, is suitable for plastic design.

The preceding comparisons of strength have been made on a non-dimensional basis. For a given force ratio and joist cross-section, the calculated M_p' is of course reduced when a rigid joint is replaced by a semi-rigid joint. A relevant parameter is the ratio of M_p' to M_{pj}' , the plastic moment of the joist section alone. Values for the eight beams are given in Table 1. The plated joists of the SB series are not directly comparable with the HB series of beams, but the figures for HB 50 and 52 show that a semi-rigid joint can develop the strength of the joist section alone with a force ratio of about 0.35. The plastic moment at midspan is likely to exceed that of the joist alone by between 50 and 150 per cent. Thus if 'simple' supports at both ends of a beam are replaced by semi-rigid joints with $M_p'/M_{pj}' = 1$, the carrying capacity (for distributed load) is increased by between 67 and 40 per cent, which should easily pay for the additional connectors and the extra cost of the joints.

Beam	d mm	b mm	A_g cm ²	f_y N/mm ²	Φ	M_p' kN-m	$\frac{M_p'}{M_{pj}'}$	$\frac{d-2r}{w}$	Web ratio	$\frac{\theta}{\theta_e}$ at $\frac{M_p'}{2}$	$\frac{W_s}{W_p}$
HB 50	206	132	32.1	310	0.34	86	1.07	32.4	0.86	-	-
SB 8	201	135	32.5	320	0.42	108	1.31	32.6	0.87	-	-
HB 51	305	166	50.7	277	0.16	78	0.42	46.4	0.90	1.15	1.01
HB 52	305	166	50.7	277	0.35	171	0.93	46.0	1.14	1.26	0.76
HB 53	304	165	50.6	293	0.44	229	1.31	43.4	1.11	1.04	0.70
HB 41	260	102	27.9	330	0.27	126	1.46	40.5	1.08	-	-
HB 54	395	145	50.5	315	0.41	286	1.27	56.4	1.50	1.22	0.65
SB 6	398	141	47.5	320	0.38	317	1.38	61.5	1.64	-	-

Table 1

Behaviour at working load. When design is governed by deflexion, it is most advantageous to provide continuity at supports. The midspan deflexion of a uniform elastic fixed-ended beam is only 20 per cent of that of a similar simply-supported beam, for the same span and distributed load. If, in a composite beam, the flexural rigidity of the negative moment regions is half that

of the midspan region, the ratio is still only 29 per cent. The ratios θ/θ^e in Table 1 show that when a semi-rigid joint is used, the end rotation of the negative moment region may exceed that given by elastic theory by about 20 per cent. The increase in the deflexion due to this is offset in a continuous beam by a slight reduction in the length of the negative moment regions, and the ratio (29 per cent) increases only to 30 per cent. Even if the design load for the beam is 50 per cent greater than that of the simply-supported beam, its deflexion is still much less.

In these simple calculations, other factors influencing deflexion, such as shrinkage and creep of concrete, have been neglected. But even here, the continuous beam has an advantage. Shortening of the slab relative to the steel joist causes additional deflexion in a simply-supported beam, but not in an interior span of a continuous beam.

Finally, the longitudinal slip of the bolted joints is considered. The ratios W_s/W_p (Table 1) show that slip was first detected at $1.04M_p'$ in HB 51 and at about $0.7M_p'$ in HB 52 to 54. The negative moment at working load depends on the redistribution of moment due to cracking of the slab and on the safety factors used. It may be necessary to design for first slip at a higher proportion of M_p' than 0.7.

The loads at first slip given above are lower than was intended. The joints were designed using a slip factor of 0.45, and the nuts were tightened by the part-turn method. Slip first occurred at loads corresponding to apparent coefficients of friction (based on a nominal bolt tension of the proof load) ranging from 0.32 to 0.36. It has been shown (11) that the true coefficient of friction (slip load/bolt tension at slip) is dependent on the condition of the faying surfaces and the bolt tension at slip. The steel angles used in the joints tested had a slightly pitted surface. This would cause higher local stresses (as also does the use of the part-turn method of tightening) resulting in premature local yielding and increased relaxation of the bolt. It is believed that both these effects reduce the slip factor. Further study of this behaviour is in progress.

Conclusions

1. Semi-rigid joints of the type shown in Fig. 4 can be made with strengths exceeding the plastic moment of resistance of the steel joist. They provide a well-defined stiffness and moment of resistance at a support, of which advantage can be taken in the design of the beams; and yet should be much cheaper than a fully-rigid joint.
2. Tests on five specimens, covering the whole range of web slendernesses available in Universal beams, showed that negative moment regions with semi-rigid joints have greater resistance to buckling and much greater rotation capacity than rigid-jointed members of similar cross-section. Thus the limiting slendernesses of rolled sections that can be used in plastic design are increased when semi-rigid joints are used.
3. Appreciable strain hardening can occur in negative moment regions before the design collapse load of a continuous beam is reached, but it should not be necessary to design shear connectors and transverse reinforcement in a negative moment region to resist a longitudinal shear exceeding that at M_p' .

Acknowledgements

The authors acknowledge with thanks the assistance of two undergraduates, A.H. Davis and A.M. Neal, who conducted the first test as a third-year project; and are most grateful to the British Constructional Steelwork Association for its support of the research at the Universities of Cambridge and Warwick, of which this work forms a part.

References

1. Garcia, I., and Daniels, J.H., 'Tests of composite beams under negative moment'. Fritz Eng. Lab. Report No. 359.1, Lehigh University, Feb. 1971.
2. Johnson, R.P., 'Research on steel-concrete composite beams'. Proc. Amer. Soc. Civ. Engrs., Vol. 96, No. ST3, March 1970, pp. 445-459.
3. Basu, A.K. and Sommerville, W., 'Derivation of formulae for the design of rectangular composite columns', Proc. Instn. Civ. Engrs., Supp. Vol., 1969, pp. 233-280.
4. Daniels, J.H. et al., 'Behaviour of composite-beam to column joints'. Proc. Amer. Soc. Civ. Engrs., Vol. 96, No. ST3, March 1970, pp. 671-685.
5. Barnard, P.R., 'Innovations in composite floor systems'. Paper presented to Canadian Structural Engineering Conference, 1970. Canadian Steel Industries Construction Council, 1970, pp. 13.
6. Joint Committee on fully rigid multi-storey welded steel frames. Second Report. Institution of Structural Engineers, 1971. pp. 12.
7. Johnson, R.P., et al., 'A plastic composite design'. Proc. Instn. Civ. Engrs. Vol. 32, Oct. 1965, pp. 198-209.
8. Climenhaga, J.J., Local buckling in composite beams. Ph.D. thesis, University of Cambridge, 1970.
9. Johnson, R.P. et al., 'Stud shear-connectors in hogging moment regions of composite beams'. Struct. Engr., Vol. 47, Sept. 1969, pp. 345-350.
10. Johnson, R.P., 'Longitudinal shear strength of composite beams'. Proc. Amer. Conc. Inst., Vol. 67, June 1970, pp. 464-6.
11. Cullimore, M.S.G. et al., 'The use of friction-grip bolts in structural steelwork'. Report on CIRIA Project 4/5/50, University of Bristol, Nov. 1969.

Summary

It is shown that neither 'simple' nor 'rigid' beam-column joints are ideal for use in steel-concrete composite framed structures for buildings. A new type of semi-rigid joint is described, and is shown by tests to have a well-defined flexural strength and a much greater rotation capacity than a rigid joint. It should also be cheaper. Its use should enable frames having joists of slender cross-section to be designed by simple plastic theory.