

Prediction of thermal residual stresses in hot-rolled plates and shapes of structural steel

Autor(en): **Alpsten, Göran A.**

Objektyp: **Article**

Zeitschrift: **IABSE congress report = Rapport du congrès AIPC = IVBH
Kongressbericht**

Band (Jahr): **9 (1972)**

PDF erstellt am: **19.09.2024**

Persistenter Link: <https://doi.org/10.5169/seals-9638>

Nutzungsbedingungen

Die ETH-Bibliothek ist Anbieterin der digitalisierten Zeitschriften. Sie besitzt keine Urheberrechte an den Inhalten der Zeitschriften. Die Rechte liegen in der Regel bei den Herausgebern.

Die auf der Plattform e-periodica veröffentlichten Dokumente stehen für nicht-kommerzielle Zwecke in Lehre und Forschung sowie für die private Nutzung frei zur Verfügung. Einzelne Dateien oder Ausdrucke aus diesem Angebot können zusammen mit diesen Nutzungsbedingungen und den korrekten Herkunftsbezeichnungen weitergegeben werden.

Das Veröffentlichen von Bildern in Print- und Online-Publikationen ist nur mit vorheriger Genehmigung der Rechteinhaber erlaubt. Die systematische Speicherung von Teilen des elektronischen Angebots auf anderen Servern bedarf ebenfalls des schriftlichen Einverständnisses der Rechteinhaber.

Haftungsausschluss

Alle Angaben erfolgen ohne Gewähr für Vollständigkeit oder Richtigkeit. Es wird keine Haftung übernommen für Schäden durch die Verwendung von Informationen aus diesem Online-Angebot oder durch das Fehlen von Informationen. Dies gilt auch für Inhalte Dritter, die über dieses Angebot zugänglich sind.

DISCUSSION PRÉPARÉE • VORBEREITETE DISKUSSION • PREPARED DISCUSSION

Prediction of Thermal Residual Stresses in Hot-Rolled Plates and Shapes of Structural Steel

Evaluation des tensions résiduelles thermiques dans les tôles et les profils d'acier

Berechnung der thermischen Eigenspannungen in warmgewalzten Stahlplatten und Stahlprofilen

GÖRAN A. ALPSTEN

Dr. Techn., Docent
Sweden

INTRODUCTION

Residual stresses can play an important role in determining the strength of structural steel members, in particular with respect to the stability of compressed members, see review papers on this subject [1, 2]. Much effort has been devoted to experimental studies of residual stresses in structural steel members. However, since such experiments are tedious and very expensive, it has been possible to test only very few out of a vast number of existing shapes with different geometry, manufactured under various conditions, of several steel grades with different thermo-physical and mechanical properties etc. For the same reason, it is natural that most experimental work in this area has been deterministic rather than statistical in nature [3].

This paper presents a theoretical computerized method for determining thermal residual stresses ("cooling stresses") in structural steel plates and shapes produced by hot-rolling. Plates are included here because they are components of welded shapes. Investigations have shown that the initial residual stresses existing in the plates prior to welding may be more important than the welding stresses [4, 5]. The paper summarizes some particular aspects of the results of a more general study previously discussed in a research report in Swedish [6]. Reference is made to that report for fuller details of the theoretical method, and to [7] for an extensive discussion of the technical results with respect to residual stresses in structural steel members.

The method presented may be useful for illustrating the mechanism of formation of residual stresses, for identifying the important variables, and for studying the influence of these variables on the resulting residual stresses. An experimental study of this kind would not be feasible since it is practically impossible to separate the different variables. Another important application of the theoretical method is predictions of residual stresses, for instance, for revised manufacturing conditions or for a new steel grade -- apart from the experimental measurement being of the order of 100 times more expensive than a theoretical determination, the manufacturing of the test specimen may be excessively expensive at that investigative stage. Finally, the computer method is well suited for simulations of the statistical scatter of thermal residual stresses as influenced by scatter in the relevant variables.

The study is based upon an evaluation of the non-stationary thermal history and the

thermal stress-strain state during the manufacturing process. A finite-difference solution was developed and the numerical computations were performed on a digital computer. Plastic and viscous deformations were considered, including the effect of variable properties with temperature.

The method of analysis is applicable also to studies of several other thermal stress problems, such as determining the temperature-time field and thermal stresses for a structural steel member exposed to fire [8], or calculating the temperature, cooling rates, and thermal strains and stresses in a quenching process, in a post-heat treatment, or in any other thermal process involved in the manufacture and fabrication of steel plates and shapes.

METHOD OF TEMPERATURE ANALYSIS

An analytical analysis of the non-stationary heat flow in cooling - with complicated boundary conditions and variable thermo-physical coefficients of the steel - is practically impossible. For this reason, a finite-difference solution of the Fourier heat conduction equation was applied. The solution is based upon the implicit alternating direction (IAD) method. The cross section is divided into a mesh with variable spacing, see Fig. 1. The governing finite-difference equation for interior mesh points may be written on the form

$$\frac{T_{ijk+1} - T_{ijk}}{\Delta t} = \frac{1}{\rho_{ijk+1/2} c_{pijk+1/2}} \left[\frac{\lambda_{i+1/2, j, k+1/2} \frac{T_{i+1, j, k+1} - T_{i, j, k+1}}{\Delta x_i} - \lambda_{i-1/2, j, k+1/2} \frac{T_{i, j, k+1} - T_{i-1, j, k+1}}{\Delta x_{i-1}}}{\frac{\Delta x_i + \Delta x_{i-1}}{2}} + \frac{\lambda_{i, j+1/2, k+1/2} \frac{T_{i, j+1, k} - T_{i, j, k}}{\Delta y_j} - \lambda_{i, j-1/2, k+1/2} \frac{T_{i, j, k} - T_{i, j-1, k}}{\Delta y_{j-1}}}{\frac{\Delta y_j + \Delta y_{j-1}}{2}} \right]$$

where T is temperature, t is time, ρ is density, c_p is specific heat, λ is thermal conductivity, and x and y are coordinates. The subscripts i and j refer to location in the cross section and k is the order of the time interval. For every second time step, the direction of integration is altered so that subscripts k and $(k+1)$ of the temperatures T are exchanged in the right member of the equation. Similarly, a finite-difference equation may be formulated for the surface mesh points, based upon the equation

$$-\lambda \frac{\partial T}{\partial n} = h (T - T_{amb})$$

where n is a coordinate normal to the surface and h is the surface coefficient of heat transfer. The detailed derivation of the finite-difference equations employed is given in [6].

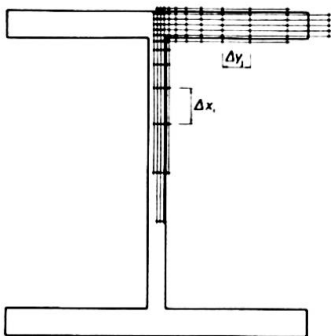

Fig. 1 Subdivision of an H-shape for finite-difference solution

The variable thermo-physical coefficients of structural steels as summarized from measurements in the literature were applied in the solution. A further complication results from the development of latent heat in the phase transformation of the steel around 727 °C. This effect was treated formally as a fictitious addition to the latent heat [6].

Results of calculations performed on a digital computer are shown in Fig. 2 as cooling

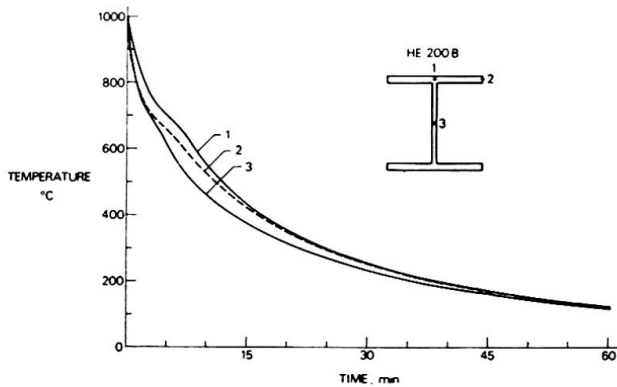

Fig. 2 Predicted cooling curves for an H-shape HE 200 B

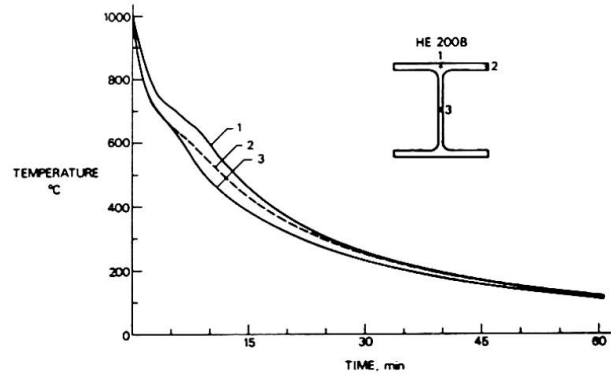

Fig. 3 Measured cooling curves for an H-shape HE 200 B

curves for three points on the cross section of an H-shape HE 200 B. This diagram may be compared with experimental cooling curves as given in Fig. 3. There is a good agreement between theory and experiment as evidenced by this comparison. Several such experimental temperature measurements were carried out and compared with calculations. For reasons which will be explained further below, a diagram of temperature differences over the cross section as a function of temperature will give a relevant representation of the cooling behavior. Figure 4 is such a diagram based upon the theoretical prediction of Fig. 2 and three repeated measurements on an HE 200 B shape. Considering the experimental scatter, and the fact that the prediction was based upon nominal average material coefficients, the agreement between prediction and measurements is most satisfactory.

METHOD OF THERMAL STRESS ANALYSIS

The thermal stress field at any instant during the cooling process may be calculated from the temperature field, considering the compatibility and equilibrium conditions. The longitudinal strain in a particular fiber (i, j) of the cross section can be written

$$\epsilon_{ijk+1} = \Delta\epsilon_{ijk+1/2}^C - (-\epsilon_{ijk}^E + \Delta\epsilon_{ijk+1/2}^T)$$

where ϵ^C is the strain increment due to compatibility conditions, ϵ^E is the elastic strain, and ϵ^T is the free thermal strain. The expression within parenthesis is the strain of a free fiber.

The formal addition of strains is represented graphically in Fig. 5, where $\Delta\epsilon$ equals $(\Delta\epsilon^C - \Delta\epsilon^T)$. Generally, the strain ϵ is composed of three parts

$$\epsilon_{ijk+1} = \epsilon_{ijk+1}^E + \epsilon_{ijk+1}^P + \epsilon_{ijk+1}^V$$

that is, an elastic, a plastic, and a viscous strain component. The elastic strain is the cause of stresses equal to

$$\sigma_{ijk+1} = E_{ijk+1} \epsilon_{ijk+1}$$

where E is the modulus of elasticity. The plastic and viscous components are accumulated as remaining deformations in the fiber considered.

The method discussed here is formally somewhat different from similar computational procedures used previously for theoretical investigations of welding residual stresses [9]. The difference is exemplified in Fig. 6 (method B for adding strains is the method discussed above). Although the method of adding stresses will lead to physically impossible results for large increments of strains [6], the differences between

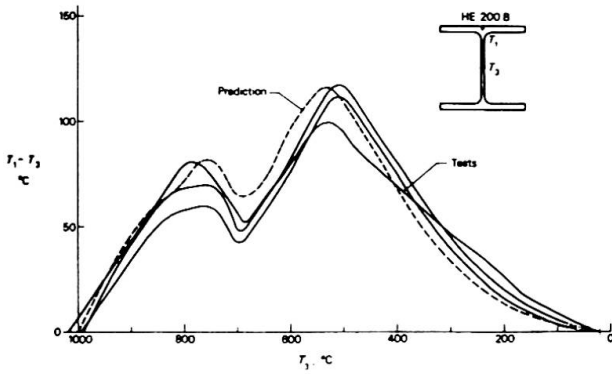

Fig. 4 Comparison between predicted and experimental cooling behavior

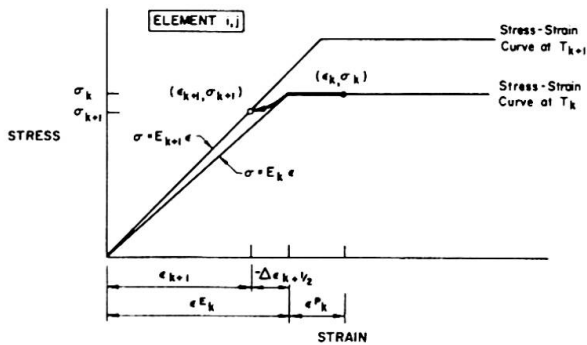

Fig. 5 Model for calculating thermal stresses at varying temperatures

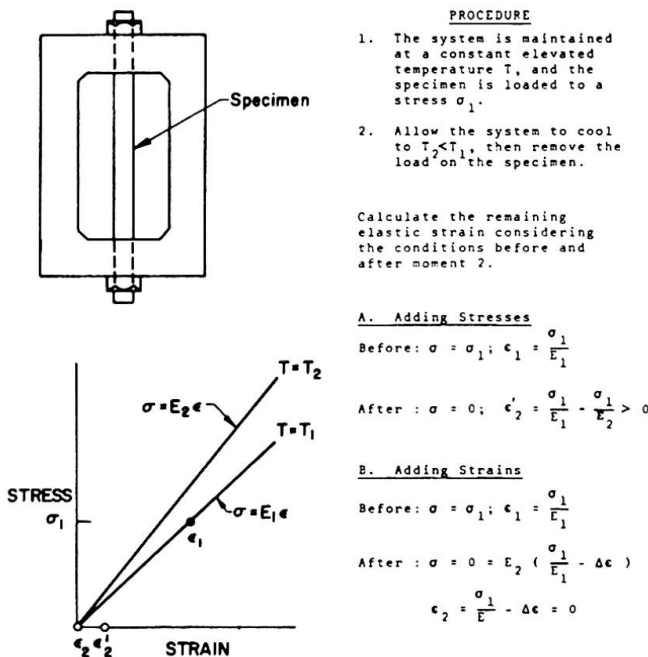

Fig. 6 Simplified model for comparison between calculation procedures

results obtained with the two methods are reasonably small for smaller strain increments.

In Fig. 5 the stress-strain curves were drawn as for elastic perfectly-plastic behavior. While this is a reasonable assumption for structural carbon steels at room temperature, real stress-strain curves at elevated temperatures are somewhat different as exemplified in Fig. 7. The dashed lines are elastic perfectly-plastic approximations fitted through the stress corresponding to 0.2 percent offset. Such approximations were applied in the present investigation. However, if sufficient mechanical data is available for a particular steel, the computational method discussed above is equally suited for a Ramberg-Osgood or some other parametric type representation of the stress-strain curve.

Figures 8 and 9 summarize limits of literature data for yield strength σ_F ($\sigma_0, 2$ at elevated temperatures) and modulus of elasticity E of structural carbon steels. Also shown are the curves used for calculations. Results of both short-time tensile tests and creep tests are included in Fig. 8. In the present investigation, the viscous deformations were included in the plastic deformations. When curves for σ_F and E are adjusted appropriately, this leads to a reasonable approximation. Figure 10 shows the implications of this assumption. Comparative calculations for cooling processes of normal-size members, including a more detailed estimation of the viscous strains, indicated that the error of the above approximate method is negligible compared to the errors resulting from an inaccurate knowledge of the short time stress-strain curve at high temperatures. This conclusion may not be correct for a heating process, where high temperatures normally are maintained at longer duration of time, for instance, when applying the method for predictions of temperatures and thermal stresses in a member exposed to fire. For such cases a detailed

PROCEDURE

1. The system is maintained at a constant elevated temperature T_1 , and the specimen is loaded to a stress σ_1 .
2. Allow the system to cool to $T_2 < T_1$, then remove the load on the specimen.

Calculate the remaining elastic strain considering the conditions before and after moment 2.

A. Adding Stresses

Before: $\sigma = \sigma_1; \epsilon_1 = \frac{\sigma_1}{E_1}$
 After: $\sigma = 0; \epsilon'_2 = \frac{\sigma_1}{E_1} - \frac{\sigma_1}{E_2} > 0$

B. Adding Strains

Before: $\sigma = \sigma_1; \epsilon_1 = \frac{\sigma_1}{E_1}$
 After: $\sigma = 0 = E_2 \left(\frac{\sigma_1}{E_1} - \Delta\epsilon \right)$
 $\epsilon_2 = \frac{\sigma_1}{E_1} - \Delta\epsilon = 0$

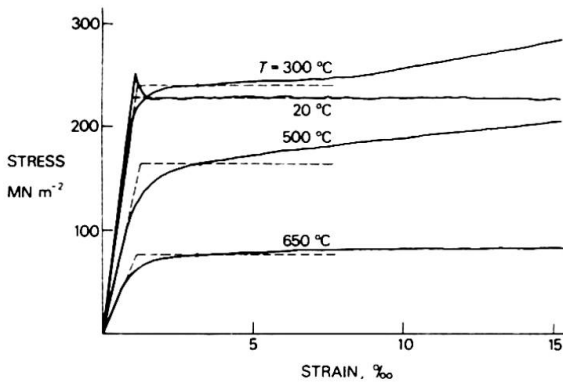

Fig. 7 Examples of stress-strain curves at different temperatures for a structural carbon steel

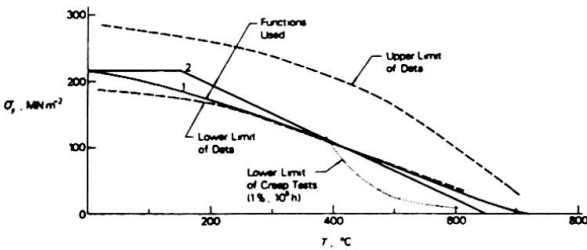

Fig. 8 Yield strength σ_F of structural carbon steels versus temperature

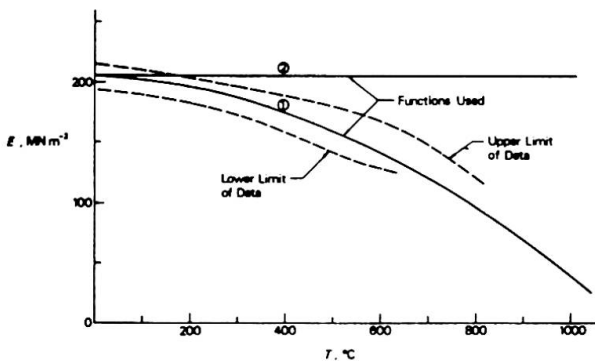

Fig. 9 Modulus of elasticity E of structural carbon steel versus temperature

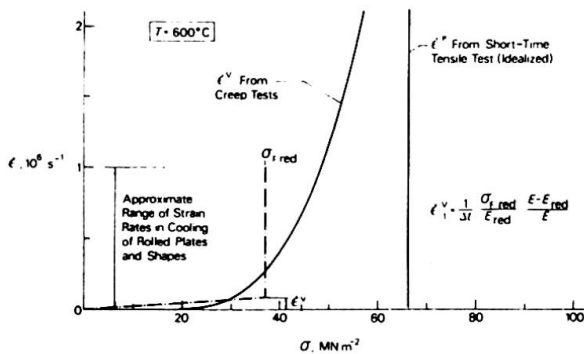

Fig. 10 Approximate method for calculating viscous strains (schematic)

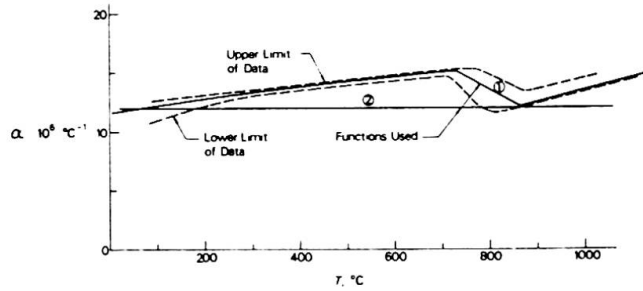

Fig. 11 Coefficient of linear expansion α of structural carbon steels versus temperature

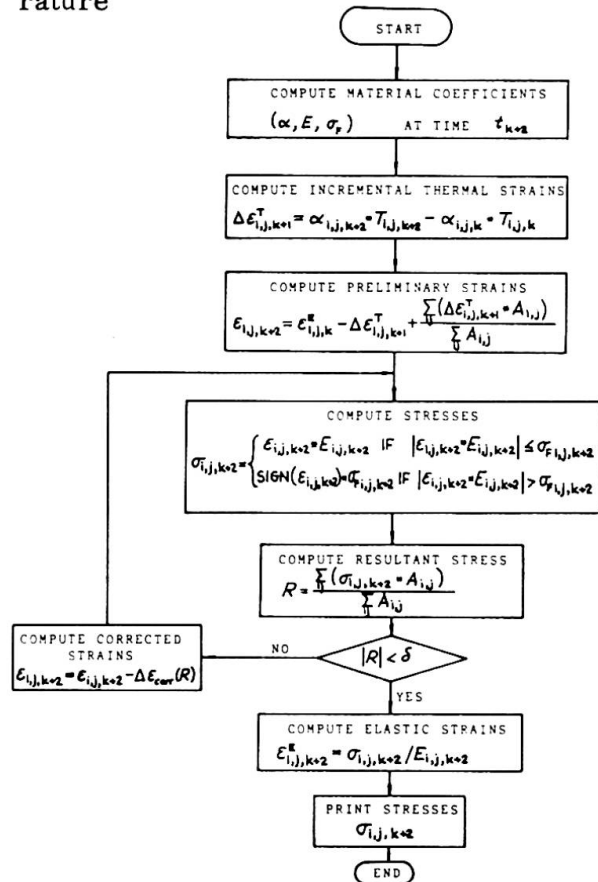

Fig. 12 Short flow diagram of subroutine for thermal stress analysis

account of the viscous deformations may become necessary. The computer procedure as discussed here (see also Fig. 12 above) has been revised to include a separate account of viscous strains. In the residual stress calculations, however, it was assumed that E_{red} in Fig. 10 is equal to E , which leads to negligible errors for normal-size shapes. For very heavy members, this assumption overestimates slightly the elastic strains and the resulting residual stresses.

A further mechanical property entering the stress-strain calculation is the coefficient of linear expansion α . Figure 11 shows the limits of literature data and the assumed functions. The relationship is influenced by the gradual phase transformation $\gamma \rightarrow \alpha$ which is accompanied by a volume expansion.

The various other conditions and assumptions involved in the calculation were discussed in detail in the original report [6]. The computer subroutine used for calculating thermal stresses is given in Fig. 12 (in this flow chart, viscous deformations are considered in σ_F but not in E).

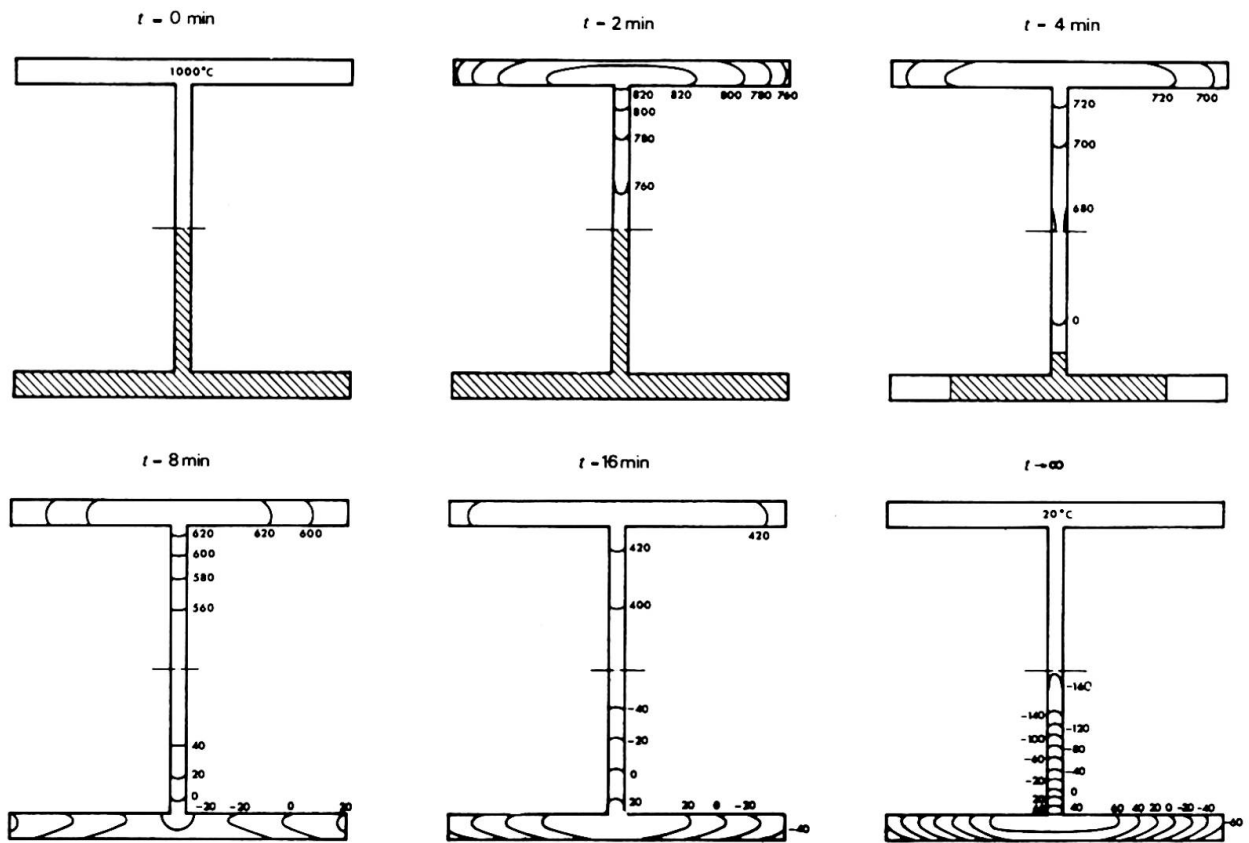

Fig. 13 Predicted cooling behavior and transient thermal stresses in an HE 200 B shape

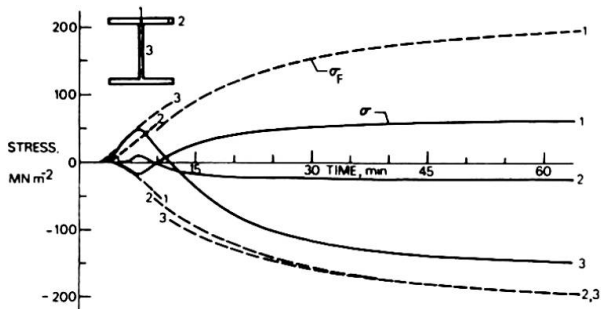

Fig. 14 Predicted thermal stress and associated yield strength as a function of cooling time, HE 200 B

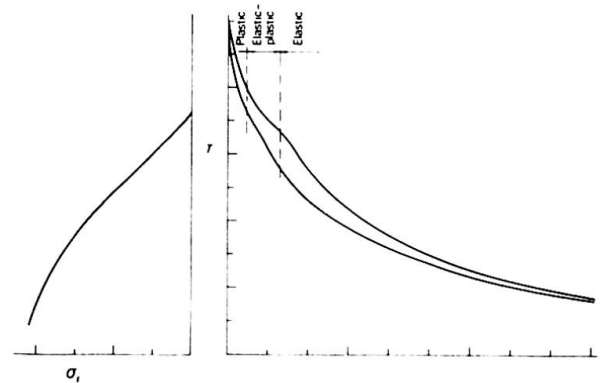

Fig. 15 Different regions of mechanical behavior during the cooling of an H-shape, HE 200 B

RESULTS

Figure 13 shows the computed temperature and thermal stress fields at different stages during cooling of an H-shape HE 200 B. A constant temperature of 1 000 °C was assumed for the initial state. The thermal stresses obtained when the member approaches the ambient temperature are the resulting residual stresses. As a rule-of-thumb, the regions cooling first will develop compressive residual stresses, balanced by tensile stresses in the remainder of the cross section.

The relative stress level at various stages of the cooling process may be studied in Fig. 14. It is interesting to note that the stresses are completely plastic and completely elastic, except for a short intermediate time interval. The three regions are indicated in Fig. 15. The intermediate elastic-plastic region is closely related to the temperature range where the yield strength approaches zero. The important implication is that temperature differences existing in this intermediate temperature range are the major cause of residual stresses to form after cooling to ambient temperature.

The influence of various assumptions on the residual stresses may be studied in Fig.16. In summary, the initial temperature state is not an important variable; constant thermo-physical coefficients will lead to large deviations in the results, but reasonably small variations in the various coefficients will cause only small differences in the computed results; cooling conditions are most important in the formation of residual stresses.

In Fig. 17 is a comparison between predicted and measured residual stresses in two shapes, a light I-shape IPE 200 and a heavy H-shape W 14x426, weighing 22.4 and 632 kg per linear meter, respectively. The diagrams give an idea of the agreement between predictions and tests for two shapes towards the ends of the span of different existing rolled shapes. A comparison between Figs. 17 a and 17 b also gives an indication of the effect of geometry on the magnitude of residual stresses.

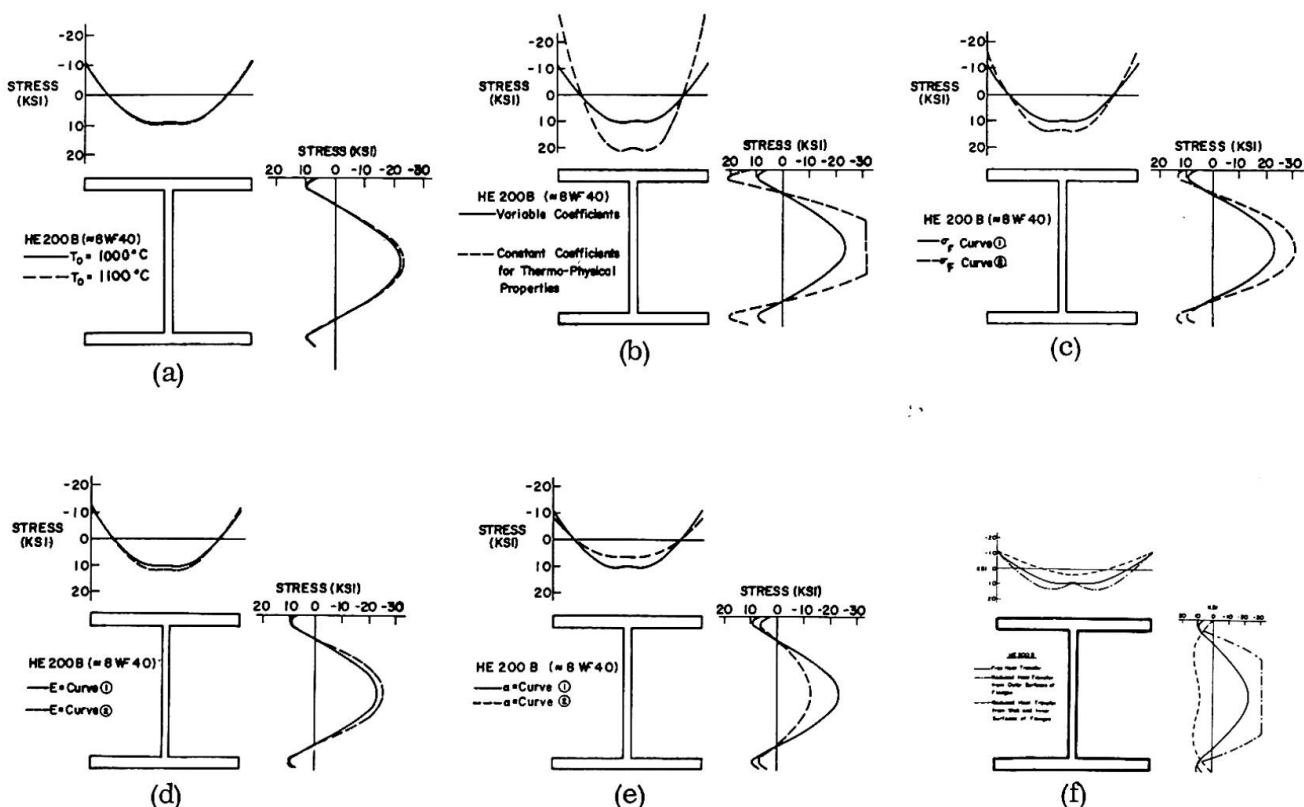

Fig. 16 Influence of different assumptions on the predicted residual stresses, HE 200 B (Scales graded in ksi. 1 ksi=6.9 MN/m²)

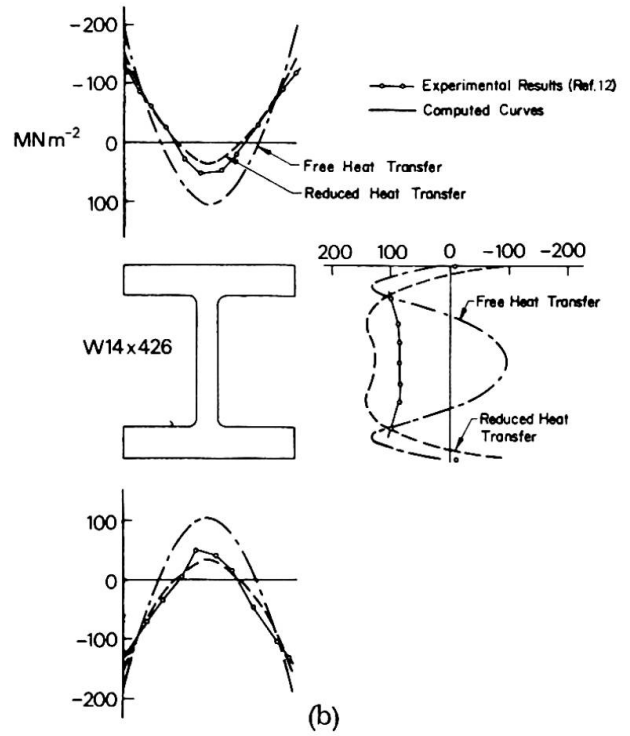
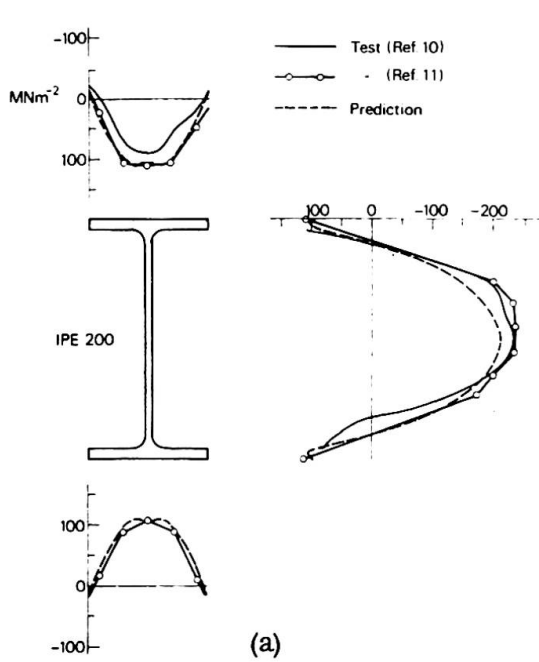

Fig. 17 Predicted and measured residual stresses in (a) a light I-beam IPE 200 and (b) a heavy H-shape W 14x426

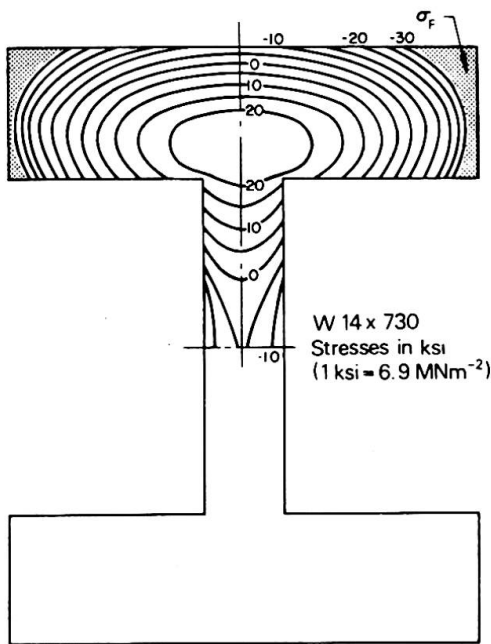

Fig. 18 Predicted two-dimensional variation of residual stresses in a "jumbo" shape W 14x730

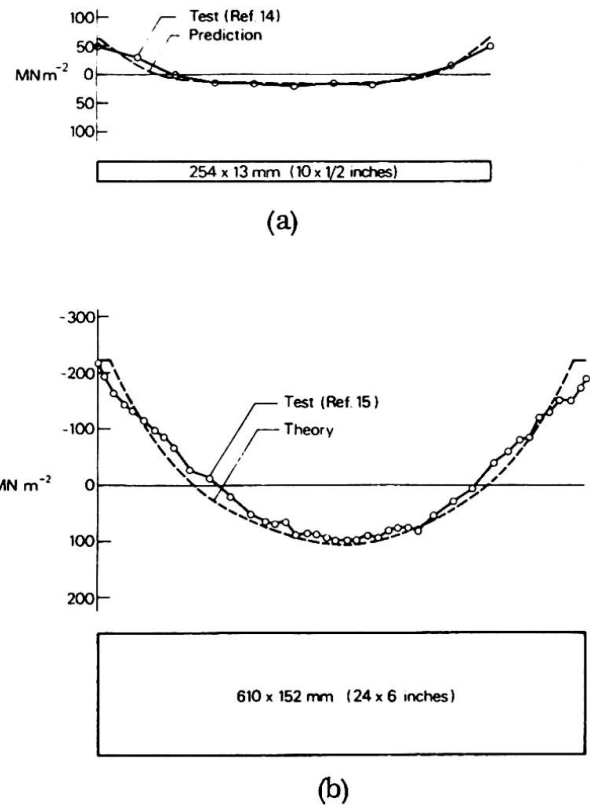

Fig. 19 Predicted and measured residual stresses in two universal-mill plates with as-rolled edges

Figure 18 shows the predicted two-dimensional variation of residual stresses in a still heavier H-shape W 14x730, that is the heaviest "jumbo" shape being rolled in the U.S. today. The calculated temperature differences in this extremely heavy shape (1 087 kg/m) are sufficient to cause residual stresses approaching the yield at the flange tips. Another important feature is the great through-thickness variation of residual stresses. Experimental measurements of residual stress have been carried out also for this "jumbo" shape [13]. The measured residual stresses were, however, much lower than predicted in Fig. 18, probably because the test member had been cold-straightened after cooling in the mill.

The effect of geometry on cooling residual stresses, as predicted by the theory [6,7], and as exemplified in Fig. 17, has been verified also by experiments on universal-mill plates with as-rolled edges [15]. Two examples are shown in Fig. 19. The compressive residual stress in the heavy plate is about three times greater than in the smaller plate. Thus, member size and geometry is one of the major variables affecting thermal residual stresses in hot-rolled plates and shapes.

Residual stresses affect the strength of centrally loaded columns. The variation of residual stresses as caused by different shape size may reduce the maximum strength by as much as 30 percent [2,7]. Thus, it appears necessary that the detrimental effect of high residual stresses be considered in the design of steel columns. Alternatively, measures should be taken to limit such stresses below acceptable values. A controlled roller-straightening procedure could be used for this purpose [16]. Experimental studies of roller-straightened columns have shown that the column strength may be increased by 10 to 15 percent from the roller-straightening process, even for a shape HE 200 A with relatively small thermal residual stresses [17].

REFERENCES

1. L. S. BEEDLE and L. TALL: Basic Column Strength. Journal of the Structural Division, ASCE, Vol. 86, No. ST7, July 1960, pp. 139 - 173.
2. L. TALL and G. A. ALPSTEN: Prediction of Behavior of Steel Columns Under Load. IABSE Symposium on Concepts of Safety of Structures and Methods of Design, London, September 1969, pp. 179 - 190.
3. L. TALL and G. A. ALPSTEN: On the Scatter in Yield Strength and Residual Stresses in Steel Members. IABSE Symposium on Concepts of Safety of Structures and Methods of Design, London, September 1969, pp. 151-163.
4. G. A. ALPSTEN and L. TALL: Residual Stresses in Heavy Welded Shapes. Welding Journal, Vol. 49, No. 3, March 1970, pp. 93-s - 115-s.
5. G. A. ALPSTEN: Theoretical Study of Residual Stresses in Medium-Size to Heavy Welded Shapes. Paper to be presented at the 9th IABSE Congress, Amsterdam, Holland, May 1972.
6. G. A. ALPSTEN: Egenspänningar i varmvalsade stålprofiler (Residual Stresses in Hot-Rolled Steel Profiles). Institution of Structural Engineering and Bridge Building, Royal Institute of Technology, Stockholm, June 1967.
7. G. A. ALPSTEN: Thermal Residual Stresses in Hot-Rolled Steel Members. Fritz Engineering Laboratory Report No. 337. 3, Lehigh University, December 1968 (to be published in the Welding Journal).

8. G. A. ALPSTEN: Om numerisk simulering av bärförmågan hos oisolerade stålpelare utsatta för brandpåverkan (On Numerical Simulation of the Strength of Non-Protected Steel Columns Exposed to Fire). Scandinavian Research Conference on Steel Construction 1970. Final Report No. R 39:1971, National Swedish Institute for Building Research, Stockholm.
9. L. TALL: Residual Stresses in Welded Plates -- A Theoretical Study. Welding Journal, Vol. 43, No. 1, January 1964, pp. 10-s - 23-s.
10. E. MAS and C. MASSONNET: Belgium's Part in the Experimental Research on the Buckling of Axially Loaded Mild-Steel Members Conducted by the European Convention of Constructional Steelworks. Acier-Stahl-Steel, No. 9, September 1966, pp. 385 - 392.
11. M. COMO and F. M. MAZZOLANI: Ricerca teorico-sperimentale sullo svergolamento nel piano e fuori del piano dei profilati in presenza di tensioni residue (Theoretical and Experimental Research on the Buckling of H-shapes Considering Residual Stresses). Costruzioni Metalliche, Vol. 21, No. 3, May-June 1969, pp. 212 - 243
12. Y. FUJITA: The Magnitude and Distribution of Residual Stresses. Fritz Engineering Laboratory Report No. 220 A. 20, Lehigh University, May 1955.
13. J. BROZZETTI, G. A. ALPSTEN, and L. TALL: Residual Stresses in a Heavy Rolled Shape 14WF730. Fritz Engineering Laboratory Report No. 337.10, Lehigh University, February 1970.
14. N. R. NAGARAJA RAO and L. TALL: Residual Stresses in Welded Plates. Welding Journal, Vol. 40, No. 10, October 1961, pp. 468-s - 480-s.
15. R. BJØRHOVDE, J. BROZZETTI, G. A. ALPSTEN, and L. TALL: Residual Stresses in Thick Welded Plates. Fritz Engineering Laboratory Report No. 337.13, Lehigh University, June 1971.
16. G. A. ALPSTEN: Egenspanningar och materialhållfasthet i kallriktade bredflänsprofiler (Residual Stresses and Mechanical Properties of Cold-Straightened H-Shapes). Jernkontorets Annaler, Vol. 154, No. 6, 1970, pp. 255 - 283.
17. O. ERSVIK and G. A. ALPSTEN: Experimentell undersökning av knäckhållfastheten hos bredflänsprofiler HE 200 A riktade på olika sätt (Experimental Investigation of the Column Strength of Wide-Flange Shapes HE 200 A Roller-Straightened in Different Manners). Swedish Institute of Steel Construction, Stockholm, Report 19:3, December 1970.

SUMMARY

A computerized method for predicting thermal residual stresses in hot-rolled steel plates and shapes is presented. The procedure is based upon a finite-difference solution using an implicit alternating direction method for calculating the non-stationary heat flow. From the temperature field the transient thermal stress-strain conditions are evaluated, considering elastic, plastic, and (approximately) viscous strain components, and taking into account the variable mechanical coefficients of structural carbon steel. Predicted temperature-time curves and residual stress distributions agree well with experimental results. The method is applicable also to several other types of thermal problems.

RESUME

On présente ici une méthode, utilisant l'ordinateur, pour prédire les tensions thermiques résiduelles dans les plaques et les coques en acier laminé à chaud. Ce procédé est basé sur une solution aux différences finies utilisant pour calculer le flux thermique non-stationnaire une méthode implicite aux directions alternantes. On évalue les conditions transitoires d'allongement et de tensions thermiques à partir du champ des températures, considérant les composantes d'allongement élastiques, plastiques et (approximativement) visqueuses et tenant compte des coefficients mécaniques variables de l'acier de construction au carbone. Les courbes température-temps et les distributions des tensions résiduelles obtenues, concordent bien avec les résultats expérimentaux. La méthode est aussi applicable à d'autres types de problèmes thermiques.

ZUSAMMENFASSUNG

Es wird eine mittels Computer durchgeführte Methode zur Vorausbestimmung von Eigenspannungen in warmgewalzten Stahlblechen und Stahlprofilen vorgelegt. Der Vorgang stützt sich auf eine endliche Differenzlösung unter Verwendung einer impliziten Methode zur Berechnung des nichtstationären Wärmeflusses. Aus dem Temperaturfeld werden die transienten thermischen Eigenspannungsbedingungen ausgewertet unter Berücksichtigung der elastischen plastischen und (annähernd) viskosen Spannungskomponenten und unter Berücksichtigung der variablen mechanischen Koeffizienten von Kohlenstoffstahl. Die vorausgesagten Temperatur/Zeit-Kurven und die Verteilung der Eigenspannungen stimmen mit den experimentellen Ergebnissen gut überein. Die Methode ist auch auf verschiedene andere Typen thermischer Probleme anwendbar.

Leere Seite
Blank page
Page vide