

Concrete element joints for immediate load transference

Autor(en): **Gerholm, T.**

Objektyp: **Article**

Zeitschrift: **IABSE congress report = Rapport du congrès AIPC = IVBH
Kongressbericht**

Band (Jahr): **7 (1964)**

PDF erstellt am: **22.09.2024**

Persistenter Link: <https://doi.org/10.5169/seals-7892>

Nutzungsbedingungen

Die ETH-Bibliothek ist Anbieterin der digitalisierten Zeitschriften. Sie besitzt keine Urheberrechte an den Inhalten der Zeitschriften. Die Rechte liegen in der Regel bei den Herausgebern.

Die auf der Plattform e-periodica veröffentlichten Dokumente stehen für nicht-kommerzielle Zwecke in Lehre und Forschung sowie für die private Nutzung frei zur Verfügung. Einzelne Dateien oder Ausdrucke aus diesem Angebot können zusammen mit diesen Nutzungsbedingungen und den korrekten Herkunftsbezeichnungen weitergegeben werden.

Das Veröffentlichen von Bildern in Print- und Online-Publikationen ist nur mit vorheriger Genehmigung der Rechteinhaber erlaubt. Die systematische Speicherung von Teilen des elektronischen Angebots auf anderen Servern bedarf ebenfalls des schriftlichen Einverständnisses der Rechteinhaber.

Haftungsausschluss

Alle Angaben erfolgen ohne Gewähr für Vollständigkeit oder Richtigkeit. Es wird keine Haftung übernommen für Schäden durch die Verwendung von Informationen aus diesem Online-Angebot oder durch das Fehlen von Informationen. Dies gilt auch für Inhalte Dritter, die über dieses Angebot zugänglich sind.

IV b 3

Concrete Element Joints for Immediate Load Transference

Joints d'éléments en béton pour transmission immédiate des efforts

Betonelementverbindungen für direkte Lastübertragung

T. GERHOLM

Malmö

In building frameworks and arches, steel construction has as a rule one advantage over concrete; the fact that the joints are able to transfer loads as soon as the jointing is made. This means that there is no delay in the building work. A concrete joint made in situ cannot transfer any load at once and the same is true when building with prefabricated concrete elements, using ordinary jointing methods.

In our experiments we are trying to find ways of making concrete element joints which do not have this disadvantage. The tests have shown that this can only be done by adopting the methods used in building with steel. We therefore have steel parts protruding from the ends of the concrete elements. Similar methods have been used by A. AMIRIKIAN in the U.S.A.

The jointing is made in two stages: first, the connection of the steel and then the concreting of the joint, which can be done later. The strength of the joint, being equal to the structural parts around it, can be made

- a) to the full extent at once by the jointed steel, in which case the surrounding concrete is only for protecting, or
- b) to some extent by the jointed steel parts, and only completed after the joint is concreted with or without shear reinforcement.

Both these methods have been tried.

A. When jointing concrete elements with the use of protruding beams, these are designed for taking the entire load and jointed to full strength. Fig. 1 shows a joint made by using I-beams which are first bolted together in order to keep the different parts in place and later on welded.

The same joints have been made without welding, using friction bolts (Fig. 2), and also with other kinds of steel girders. Cracks from a test are shown in Fig. 3: these are typical. The vertical cracks at the ends show the ends of the jointing steel girders.

This method of jointing has some disadvantages. The costs are rather high because much jointing steel is used. To have friction bolts also requires great precision, because the holes have to fit when the elements are placed in position; if the holes are made after the beams are in place, this causes extra work,

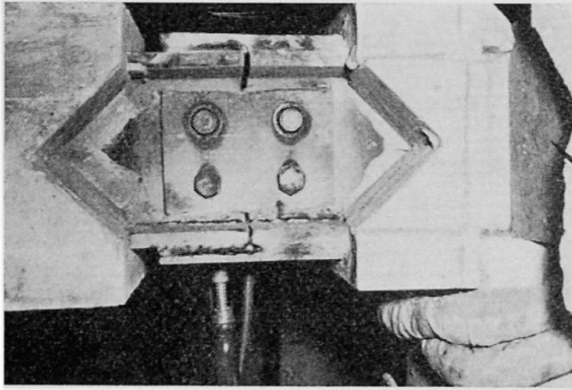

Fig. 1. A joint made by using two extended I-beams locked and welded together.

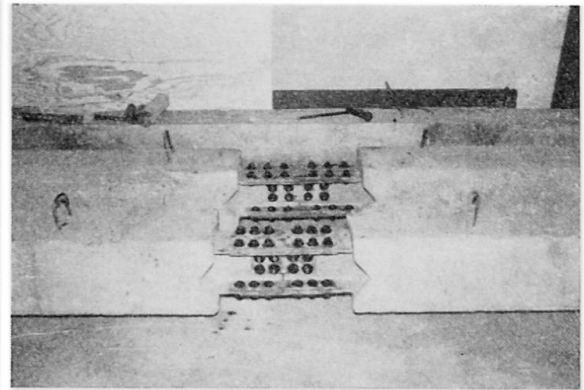

Fig. 2. Same joint as before using friction bolts for the connection of the beams.

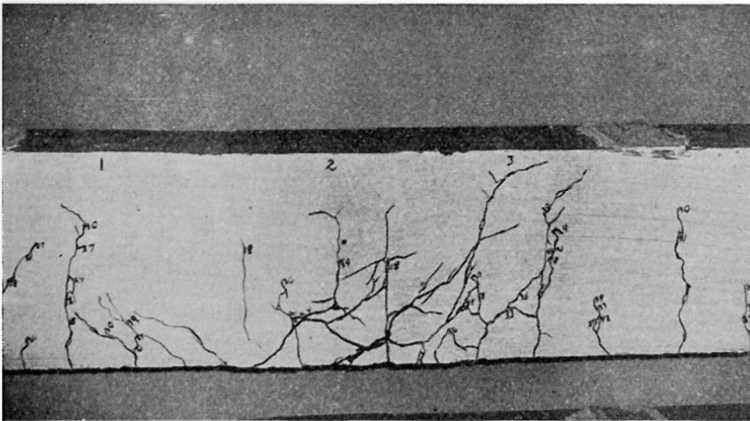

Fig. 3. From a test of beams shown in Fig. 1. Typical cracks at the ends of the I-beams.

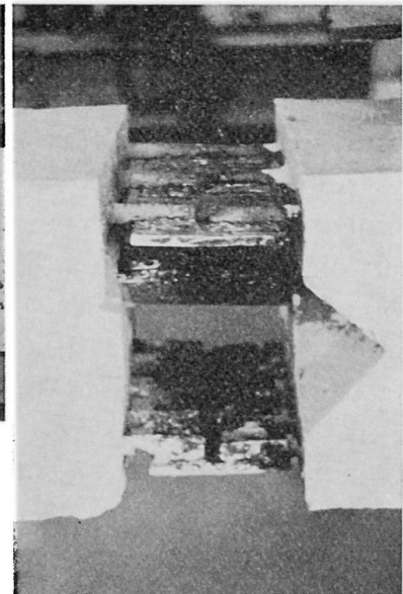

Fig. 4. Jointing of reinforcing bars, using steel plates lying under the bars.

time and cost. If a mistake is made and the elements are too long, it is hard to correct it on the building site. Another point is that the total load practically never has to be taken at once because the dead load is generally much lower than the design load. Consequently, we continued with B.

B. If the steel joint is only to take part of the design load, this part must be at least equal to the dead load in order to give a safety factor. In this case we have used the reinforcing bars for jointing. The bars protrude far enough for the welding to be done. The joint steel normally consists of plates or reinforcing bars. In the beginning we used steel plates, one in the top reinforcement and one at the bottom, lying in some cases under the reinforcing bars (see Fig. 4), in other over them (see Fig. 5). Another and better way is to use bent steel plates, jointing each bar with the opposite one (Fig. 6). When jointing the reinforcing steel, it is necessary to have some way of fixing the concrete

elements in the right position when welding. This is easily done by using protruding bent steel plates and L-irons, so fixed in the concrete that the right position is obtained when placing the element to be jointed (e. g. a beam) on the elements already in position (e. g. two columns). See Fig. 5.

We have tested these joints before and after concreting. The factor of safety figure on the design load was about 1.5 before and about 3 after; in the latter case the same as for the beam without any joint. Fig. 7 shows such a beam after the test. Fig. 8 is from a combined test of jointed beams, using two different ways of welding and without any joint. The failures came at about

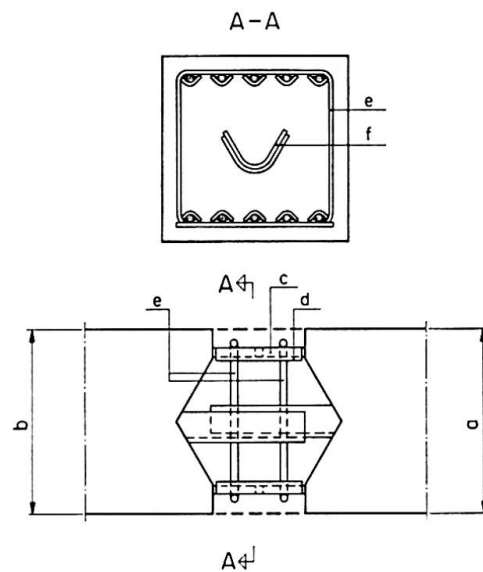

Fig. 5. Joints made by using bent steel plates. The plate and the bars have the same centre joint and the jointing steel is not to be deformed, as shown in Fig. 6. Note the use of the supporting steel elements for keeping the concrete elements in place before welding. The shear reinforcement is an extra safety factor.

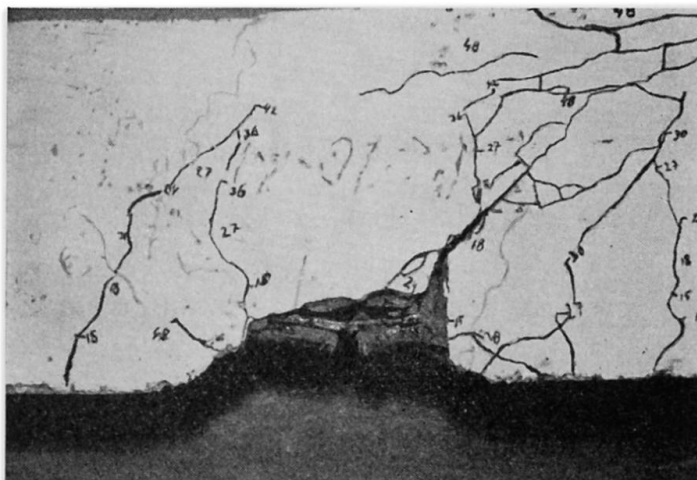

Fig. 6. Same joint as 4, with the plate lying over the bars. The photo taken after the failure of the beam. The concrete is thrown out due to the bending of the jointing steel.

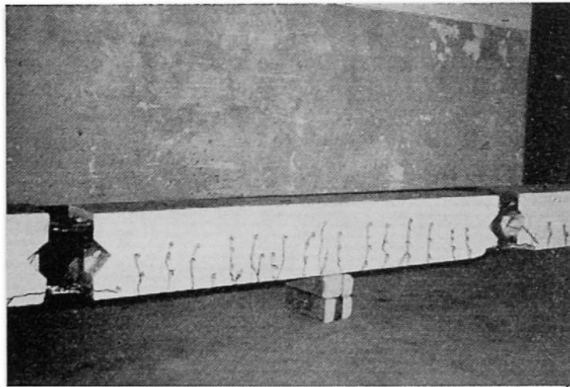

Fig. 7. A beam made as shown in Fig. 4 after the test. The safety factor figured on the design load was 1.5, on the building load about 3.

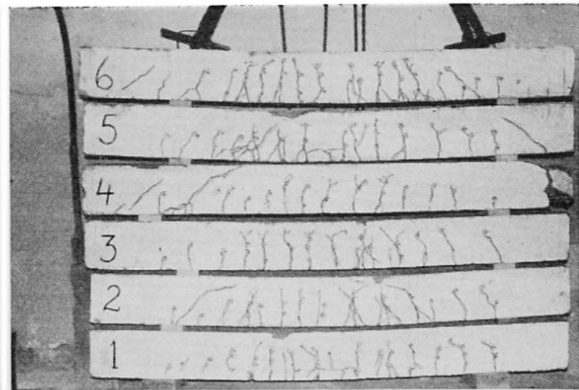

Fig. 8. The beams are designed for the same load. 1 and 2 are made as in Fig. 4. 3 and 4 are not jointed. 5 and 6 are as shown in Fig. 4 welded together. The results were about the same for all beams.

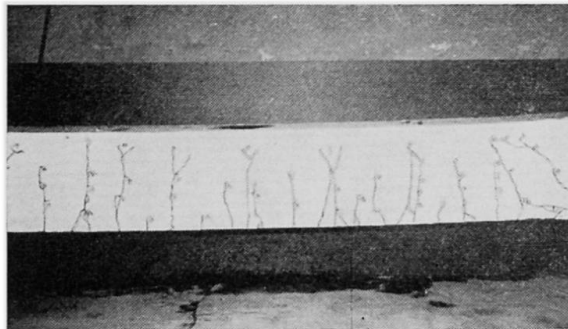

Fig. 9. Same beam as in Fig. 8, but with the bent plate joint. Compare with beam 3.

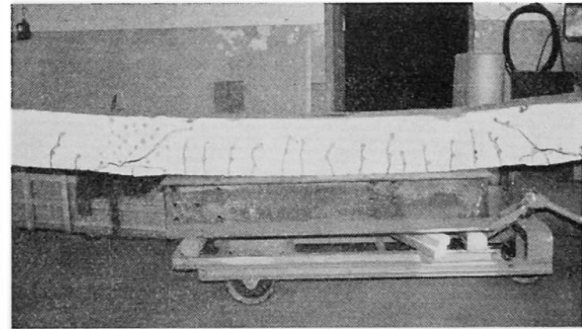

Fig. 10. A beam jointed as in Fig. 4 and loaded after failure in order to study the cracks.

the same loads, with no tendency to show which beam was better. In these tests we used combined jointing with one steel plate on top and one at the bottom, both lying under the reinforcing steel. Fig. 9 shows a beam of the same type with the bent plate jointing. The cracks are different, but similar to 3 on Fig. 8.

Fig. 10 is a beam loaded after failure to see how the joints behave. The jointing places are easy to locate. Note the horizontal cracks. What happens can be examined in Fig. 5 and explains the reason for the use of the bent plate jointing, where the centre of stress in the bar and the jointing steel is the same. The bent plate can be changed to two reinforcing bars opposite each other. We considered it easier, however, to weld when using the bent plate.

The beams were normally designed, so that the failure could also come as a crushing of the concrete. Fig. 11 shows such a beam.

If we compare the two ways of jointing, we find that we save about 80% of the jointing steel when using reinforcing bar joints instead of jointed steel beams. The loading capacity of the joints is the same. There is another diffe-

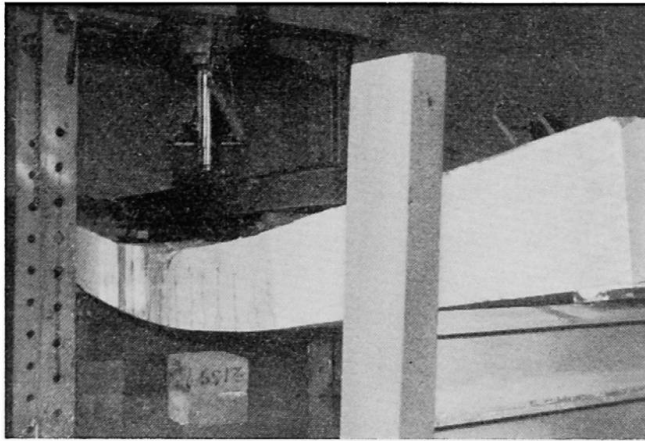

Fig. 11. A beam with a bent plate joint and failure due to crushing of the concrete.

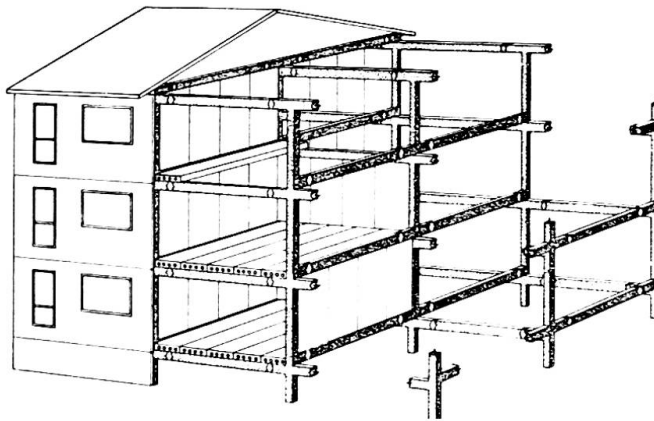

Fig. 12. A frame house built of concrete elements, showing the joints. The frame is built up of comparatively small elements.

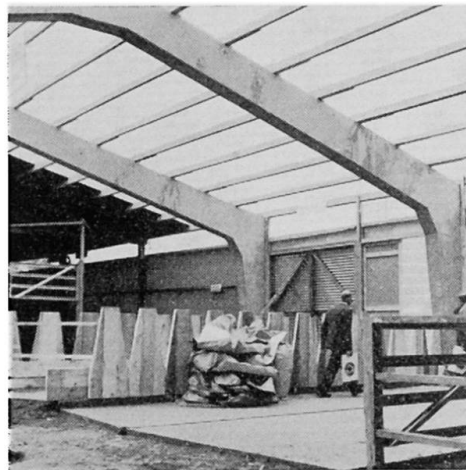

Fig. 13. Two-hinged arches made of three parts. The joints are made as shown in Fig. 5.

rence; the tolerances in length of the elements are not so strict when connecting bars. If there is a gap between the opposite reinforcing bars, this does not matter; if the elements are slightly too long, it is easy to shorten a bar.

Summary

The reason for the tests was to find ways of jointing concrete building elements which would enable the joints to transfer loads immediately. We have used protruding steel parts welded or bolted together. The tests have been carried out in full scale with regular building loads.

Résumé

Les essais ont eu pour but de trouver un mode d'assemblage des éléments en béton qui permette aux attaches de transmettre immédiatement les charges. On a utilisé des pièces métalliques faisant saillie, soudées ou boulonnées ensemble. Les essais ont été effectués en vraie grandeur, avec les charges réglementaires.

Zusammenfassung

Der Zweck der Versuche war, ein Verfahren zur Verbindung von Betonfertigteilen auszuarbeiten, damit die Fugen unmittelbar Lasten übertragen können. In unserer Versuchsreihe bedienten wir uns vorstehender Stahlteile, die entweder zusammengeschweißt oder -geschraubt wurden. Es handelte sich hierbei um Großversuche mit regulärer Betriebsbelastung.