

Zeitschrift: IABSE congress report = Rapport du congrès AIPC = IVBH
Kongressbericht

Band: 9 (1972)

Rubrik: Theme II: Interaction problems in structures

Nutzungsbedingungen

Die ETH-Bibliothek ist die Anbieterin der digitalisierten Zeitschriften auf E-Periodica. Sie besitzt keine Urheberrechte an den Zeitschriften und ist nicht verantwortlich für deren Inhalte. Die Rechte liegen in der Regel bei den Herausgebern beziehungsweise den externen Rechteinhabern. Das Veröffentlichen von Bildern in Print- und Online-Publikationen sowie auf Social Media-Kanälen oder Webseiten ist nur mit vorheriger Genehmigung der Rechteinhaber erlaubt. [Mehr erfahren](#)

Conditions d'utilisation

L'ETH Library est le fournisseur des revues numérisées. Elle ne détient aucun droit d'auteur sur les revues et n'est pas responsable de leur contenu. En règle générale, les droits sont détenus par les éditeurs ou les détenteurs de droits externes. La reproduction d'images dans des publications imprimées ou en ligne ainsi que sur des canaux de médias sociaux ou des sites web n'est autorisée qu'avec l'accord préalable des détenteurs des droits. [En savoir plus](#)

Terms of use

The ETH Library is the provider of the digitised journals. It does not own any copyrights to the journals and is not responsible for their content. The rights usually lie with the publishers or the external rights holders. Publishing images in print and online publications, as well as on social media channels or websites, is only permitted with the prior consent of the rights holders. [Find out more](#)

Download PDF: 05.04.2026

ETH-Bibliothek Zürich, E-Periodica, <https://www.e-periodica.ch>

II

**Interactions dans les structures
Wechselwirkung in Tragwerken
Interaction Problems in Structures**

II a

**Interaction de matériaux différents
Wechselwirkung zwischen verschiedenen Materialien
Interaction of different Materials**

Leere Seite
Blank page
Page vide

DISCUSSION PRÉPARÉE • VORBEREITETE DISKUSSION • PREPARED DISCUSSION

Materialoptimierung für einfach symmetrische Biegeträger

Optimization of the Material for simply symmetrical Bending Girders

Optimalisation du matériau pour poutres à flexion simplement symétriques

GÜNTER RUX
Dipl.-Ing.GERHARD LANG
Ing.ASCAN LUTTERROTH
Dipl.-Ing.KLAUS NEUMANN
Dr.-Ing.

VEB Metalleichtbaukombinat Leipzig, DDR

Bei der Optimierung von Biegeträgern durch Veränderung der Stahlmarke gibt es zwei Wege:

1. Wahl eines Stahles höherer Festigkeit für den gesamten Querschnitt
2. Wahl eines Stahles höherer Festigkeit für Teile des Querschnittes.

Bei dem zweiten Weg ist es möglich,

- 2 a) den Querschnitt symmetrisch auszubilden, d.h., Obergurt und Untergurt aus einem höherfesten Stahl als das Stegblech auszubilden. Diese Möglichkeit wurde von Daddi - Mailand, beschrieben.

Interessante Ergebnisse liefert auch der Weg

- 2 b) unsymmetrische Ausbildung des Querschnittes durch Verwendung des höherfesten Stahles nur für den Untergurt.

Durch die Verwendung eines Stahles geringerer Festigkeit im Obergurt ergeben sich Vorteile im Stabilitätsverhalten sowohl hinsichtlich des örtlichen Ausbeulens des Druckgurtes, als auch des Kippverhaltens des gesamten Trägers. Dadurch lassen sich wirtschaftliche Lösungen erreichen, wenn eine Überschreitung der zulässigen Spannung im unteren Stegblechbereich in Kauf genommen wird, wie es im Bild 1 dargestellt ist.



BILD 1

Zur Klärung des Tragverhaltens, insbesondere auch der Schubübertragung in dem bei diesem Träger schon im Gebrauchszustand teilweise plastifiziertem Stegblech sind Versuche an zwei geometrisch gleichen Trägern mit Obergurten aus St 38, Untergurten aus St 52 und Stegblechen bei einem Trä-

ger aus St 38, bei einem anderen aus St 52 durchgeführt worden. Die 6 m langen Versuchsträger waren gelenkig gelagert und durch zwei symmetrisch zur Mitte angeordnete hydraulische 20 Mp Prüfzylinder in 1,20 m Abstand belastet. Durch seitliche Führung an den Lasteintragungsstellen wurde das Kippen der Träger verhindert, so daß sie bis zur vollen Plastizierung belastet werden konnten.

Die Belastung erfolgte in mehreren Stufen mit vollständiger Zwischenentlastung. Mittels eines Theodoliten und aufgesetzter Maßstäbe an den

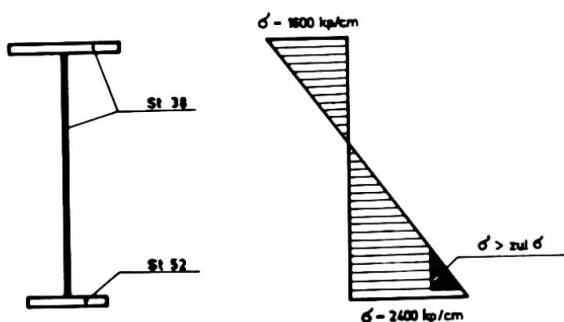
Auflagern, an den Lasteintragungsstellen und in Trägermitte sind die Durchbiegungen auf etwa 0,2 mm genau gemessen worden.



BILD 2



	Träger 1	Träger 2
M_{PLAST} [Mp]	27,7	29,2
M_{TRAG} [Mp]	32,3	34,1
Durchbiegung [mm]		
P 10,0 [Mp]	36,7	37,4
P 12,2 [Mp]	67,6	39,3

BILD 3

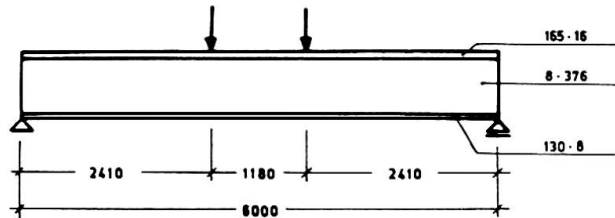
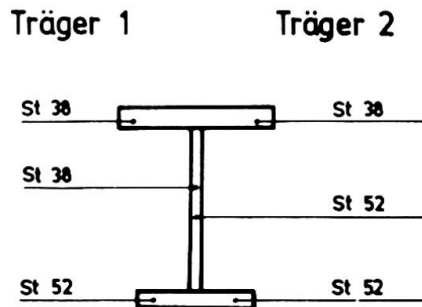
Dehnungsmessungen mit einem mechanischen Setzdehnungsmesser mit 100 mm Basis erfolgten in einem Querschnitt in Trägermitte an je 3 Stellen beider Gurte und je 5 Stellen jeder Stegseite.

Beim Vergleich der Versuchsergebnisse kann man sich bekanntlich nicht auf die Normwerte der Festigkeiten verlassen, deshalb ist nach den Versuchen die Streckgrenze und Bruchfestigkeit an Proben aus den Gurten und Stegen beider Träger bestimmt worden. Die Proben sind aus Bereichen entnommen worden, die nicht plastisch verformt waren. Die Streckgrenze des St 38 lag über dem Normwert, die des Stegbleches St 52 knapp darunter.

Das elastische Verhalten der Träger, festgestellt aus der Durchbiegungsänderung bei der Entlastung, stimmte gut mit der Theorie überein. Bei Belastung war schon bei niedrigeren Laststufen die wirkliche Durchbiegung größer als

die rechnerische, was auf örtliche Plastizierung infolge von Eigenspannungen zurückzuführen ist. Die Dehnungsmessungen bestätigten die Hypothese vom Ebenbleiben der Querschnitte auch bei plastischer Verformung.

Die ertragenen Biegemomente lagen mit 32,3 bzw. 34,7 Mp um 17 bzw. 19 % über den theoretischen vollplastischen Momenten, die mit den gemessenen Werten der Streckgrenze berechnet wurden. Die Überschreitung der vollplastischen Momente kann durch Wiederverfestigung erreicht worden sein, die bei der aufgetretenen Dehnung von etwa 10 % in den Gurten erfolgt sein kann. Außerdem ist es möglich, daß die Fließgrenze etwas höher lag als die 0,2 % - Dehnungsgrenze, die bei der Materialuntersuchung bestimmt worden ist. Die vollplastischen Momente bei Normwerten der Fließgrenze sind 25,6 bzw. 29,2 Mp m bei den vorgegebenen Querschnittsabmessungen.

Bei den Versuchen hat sich gezeigt, daß die Plastizierung der Stege im Zugbereich keinen nachteiligen Einfluß hat und daß die Träger, deren einzelne Teile aus Baustahl mit unterschiedlicher Fließgrenze bestehen, mindestens die Tragfähigkeit erreicht haben, die nach der Plastizitätstheorie berechnet werden kann. Wenn auch die Tragfähigkeit bei Ausführung des Steges aus St 52 etwas größer ist, ist doch insgesamt die Wirtschaftlichkeit besser, wenn der Steg aus St 38 besteht und eine Plastizierung im Zugbereich zugelassen wird.

Diese Ausführung ist seit 1965 in den DDR-Stahlbauvorschriften TGL 13 500 zugelassen. Dabei wird gefordert, daß die rechnerischen Spannungen im Steg unter Gebrauchslast nicht die Fließgrenze überschreiten. Das wird bei Stegen aus St 38 und Gurten aus St 52 stets eingehalten, wenn die zulässige Spannung der höherfesten Gurte nicht überschritten wird. Außerdem dürfen im überbeanspruchten Stegblechteil keine Querlasten angreifen. Zur Übertragung der Querkraft darf dieser Stegteil nicht herangezogen werden. Das zulässige Biegemoment ist nach diesem Berechnungsverfahren etwa ebenso groß wie bei der Bemessung nach dem Traglastverfahren mit den um 10 % erhöhten Sicherheitszahlen, die dort vorgeschrieben sind.

Mit Hilfe eines Rechenprogramms wurde eine optimierte Reihe von Schweiß-



BILD 4

trägern ermittelt, bei denen die Stege und Obergurte aus St 38 und die Untergurte aus St 52 hergestellt werden. Proportional zu den Streckgrenzen verhalten sich dabei die Spannungen im Obergurt zu den Spannungen im Untergurt wie 2 : 3. Bild 4 zeigt den kleinsten und den größten Vertreter dieser Auswahlreihe und die dazugehörigen maßgebenden Querschnittswerte. Bei diesen Trägern ergeben sich Stahleinsparungen von durchschnittlich 12 % und in einem weiten Anwendungsbereich günstigere Effekte, als beim ausschließlichen Einsatz der höherfesten Stahlmarke.

ZUSAMMENFASSUNG

Wirtschaftliche Biegeträger können hergestellt werden, bei denen der Zuggurt gegenüber dem Druckgurt und dem Stegblech aus einer höherfesten Stahlmarke ausgebildet wird. Bei Ausnutzung der zulässigen Spannung des Zuggurtes wird dabei der Randbereich der Stegbleche bis zur Plastizierung beansprucht. Der plastizierte Stegblechteil darf nicht zur Schubübertragung herangezogen werden und muss bei der Eintragung von Querlasten gemieden werden. Unter Einhaltung dieser Bedingungen wurde mit Hilfe eines Rechenprogrammes eine optimierte Trägerreihe aufgestellt.

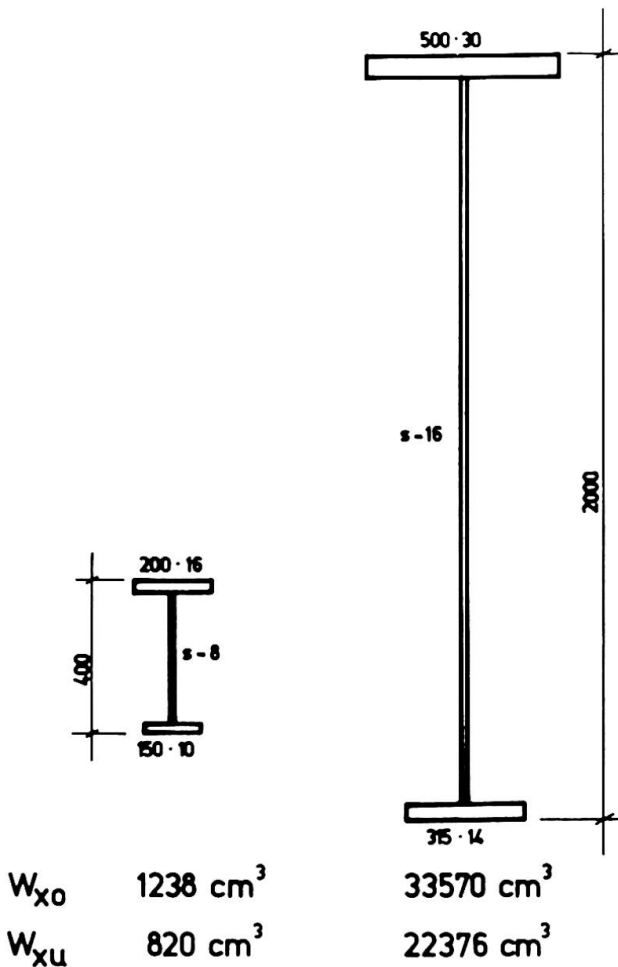
SUMMARY

It is possible to manufacture economical beams submitted to bending in choosing for the tensioned booms a high resistant steel, whereas for the booms in compression and the web plate a standard steel quality is employed. In utilizing the admissible tensions for the tensioned boom the external fibres of the web attain the plastic range. The plastized range of the web does not permit the transmission of the shearing efforts and this state has to be avoided in zones where the loads are transmitted. In taking into account these conditions a serie of economical beams has been developed with the help of a computer.

RESUME

On peut construire des poutres économiques soumises à la flexion en choisissant pour les membrures tendues un acier à haute résistance, alors que pour les membrures comprimées et l'âme on choisit un acier normal. En utilisant les tensions admissibles pour la membrure tendue, les fibres extrêmes de l'âme atteignent le domaine plastique. Le domaine plastifié de l'âme ne permet pas la transmission des efforts de cisaillement et cet état doit être évité dans les régions où sont transmises les charges. En tenant compte de ces conditions on a développé, à l'aide d'un ordinateur, une série de poutres économiques.

DISCUSSION LIBRE • FREIE DISKUSSION • FREE DISCUSSION

Discussion of the Paper "Composite Steel-Deck-Reinforced Concrete Systems Failing in Shear-Bond" by R.M. Schuster

Discussion de la contribution "Composite Steel-Deck-Reinforced Concrete Systems Failing in Shear-Bond" par R.M. Schuster

Diskussion des Beitrages "Composite Steel-Deck-Reinforced Concrete Systems Failing in Shear-Bond" von R.M. Schuster

R.P. JOHNSON
England

Static and fatigue tests on steel-deck-reinforced concrete slabs similar to those reported by R.M. Schuster were carried out at Cambridge University, England, in 1970-71. It was found that ultimate strength of the composite slabs was strongly influenced by two variables not discussed in the present paper.

The first is the detail at the edge of the slab. If the outermost corrugation of the decking can separate from the slab due to transverse bending of the deck, then the longitudinal shear strength is less than when the free edge of the decking is embedded in the slab in some way. For example, the edge detail shown in Fig. 1 of the paper would perform better than that shown in Fig. 3. The effect is of course more significant in narrow laboratory specimens than it is in practice.

The second variable is the roughness of the dimples or corrugations provided in the inclined sides of the sheets. Measurements on sheets provided by one of the same suppliers that R.M. Schuster used showed that the dimple depths ranged from 0.6 mm to 1.1 mm. The mean depths for individual sheets were more uniform (0.79 to 0.97 mm), but it is likely that the variation is sufficient to influence the shear strength of composite plates in which these sheets are used.

IIa

Discussion of the paper "Continuous Composite Beams for Bridges" by J.W. Fisher

Discussion de la contribution "Continuous Composite Beams for Bridges" par J.W. Fisher

Diskussion des Beitrages "Continuous Composite Beams for Bridges" von J.W. Fisher

R.P. JOHNSON
England

The information provided by J.W. Fisher and his co-authors on the stiffness of the negative moment region of a continuous beam is most welcome. The existing British design method for continuous composite bridge beams (CP 117 : Part 2) distinguishes clearly between assumptions to be made about stiffness, for the purpose of calculating longitudinal moments, and assumptions to be made about the stress distribution at a cross-section.

It is not clear in the present paper whether the conclusion that C_1 can be taken as 0.6 refers only to equivalent stiffness, from which bending moments can be deduced, or to the calculation of reinforcement-bar stress also. It would seem logical to calculate this stress neglecting concrete in tension altogether, in order to satisfy the equilibrium condition at a cross-section where there is a crack.

The authors show that stiffness decreases as load increases, as one would expect. Has it been established whether stiffness in service depends on the current load level or on the maximum load level previously reached? If the latter, which seems the more likely, then one would presumably base fatigue calculations on the moment distribution found using stiffnesses corresponding to maximum working load. If that load were never reached, the moments and hence the loads on connectors in the negative moment region would be higher than calculated, which could reduce fatigue life. Another problem is shrinkage. Is anything known about its influence on stiffness of negative moment regions? It is possible that predictions of loads on connectors and stresses in reinforcement in service may still be quite inaccurate.

Two Unconventional Bridges in Praha, Czechoslovakia

Deux ponts non conventionnels à Prague, Tchécoslovaquie

Zwei unkonventionelle Brücken in Prag, Tschechoslowakei

JIRÍ PECHAR
 Assoc. Professor
 Technical University of Praha
 CSSR

Two unconventional bridges there have been developed on the Technical University of Praha and now are under construction in Praha /Czechoslovakia/.

The first one is the railroad bridge shown on fig.1.

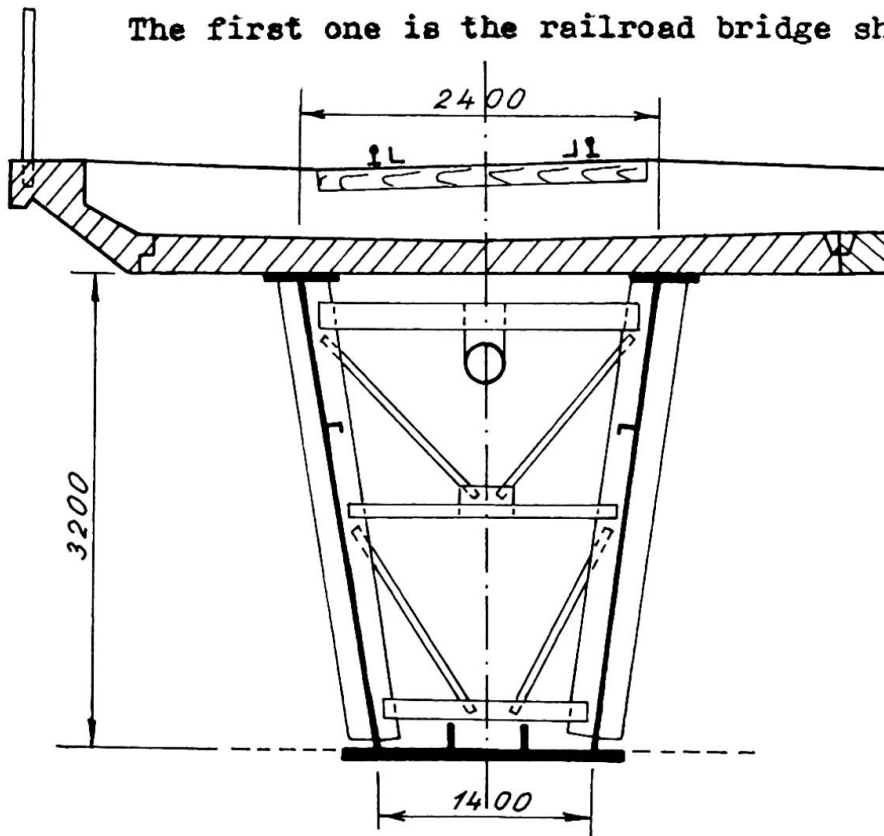

Fig.1.

The superstructure is designed in form of the steel box girder with trapezoidal cross section, connected with precast concrete deck.

The composite action of the deck and steel box girder is achieved by high strength bolts M 24. The composite structure of this type is for the first time used for heavy

railroad loading.

This bridge was developed as a standard structure. Total number of 12 such bridges will be erected in the railroad network of Praha, until now 5 of them are in operation.

The span is 46.5 m, the depth of the steel box is 3200 mm. Used steel is St 52, strength of the concrete is 500 kp/cm^2 . Each box girder is designed for one track loading. This standard section may be used for single and multi-track railroad bridges.

The second interesting bridge is the new steel bridge structure over the railroad station Praha - centre./Fig.2/.

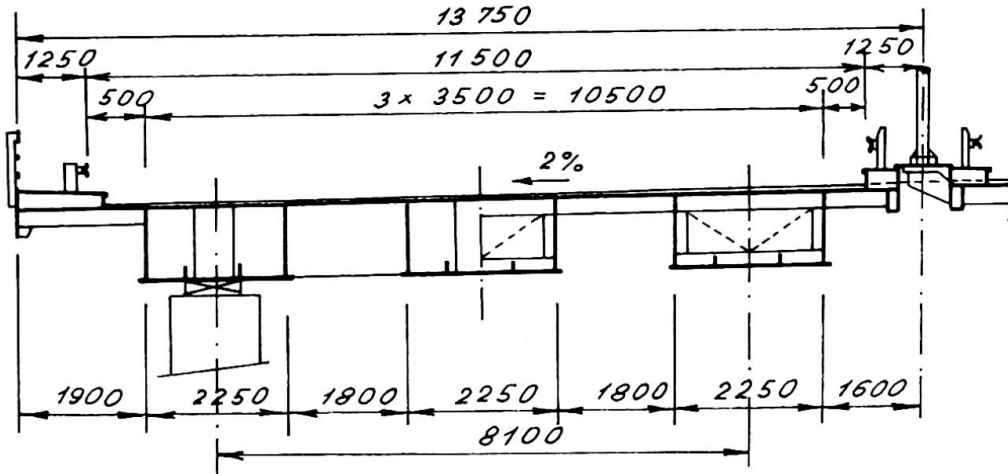

With its total length of approx. 700 m it spans also several main streets intersections in the downtown Praha.

The total bridge is composed from 18 in-

dividual bridge structures with total 48 spans and total length of 1 600 m. The spans vary from 35 to 45 m.

The carriageway is supported by steel orthotropic plate

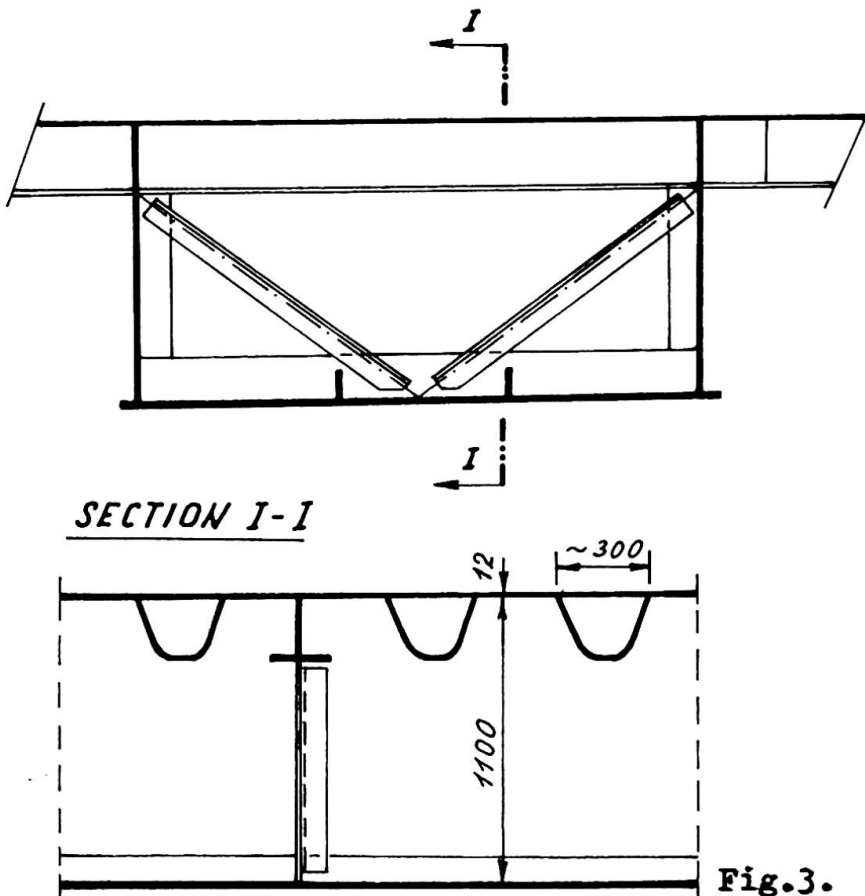

with transverse box stiffeners in trapezoidal shape /fig.3./. Spacing of transverse stiffeners is approximately 600 mm. They rest on webs of main box girders.

Transverse rigidity of the orthotropic deck is sufficient for reliable transverse load distribution. Rigid cross frames are designed at supports only. Additional diaphragms inside of boxes in the quarter and in the middle of each s

span resist the distortion of the box cross section.

The whole bridge is curved in horizontal plane.

Fig.3.

IIa

REMARQUES • BEMERKUNGEN • COMMENTS

A Survey of Using Steel in Combination with Other Materials

Relevé sur l'utilisation d'acier en combinaison avec d'autres matériaux

Übersicht über die Verwendung von Stahl in Kombination mit anderen Materialien

C.F. McDEVITT I.M. VIEST

Bethlehem Steel Corporation

Bethlehem, Pa., USA

In the introductory report (164), we expressed the hope that the prepared and free discussions contributed toward Theme IIa at the Ninth Congress IABSE would combine with the introductory report to form an authoritative world-wide survey of the theme subtopics as of 1972. Indeed, after the introductory report was published in 1970, we received a number of private communications referring to important earlier studies and applications not included in the report. Many of these omissions have either been discussed, or referred to, by the authors of the prepared discussions presented at the Ninth Congress. Other contributions, including more recent material published elsewhere, will be discussed in this final report.

The response to the request for prepared discussions on the INTERACTION OF DIFFERENT MATERIALS and the numerous new articles which have been published on this subject since 1970 make it evident that the art of combining steel with other materials is being actively explored and extensively utilized throughout the world. However, it is clear that combining steel with concrete to form composite beams, columns and floor systems has been receiving the greatest attention. Composite steel-concrete construction represents one of the older and more significant exploitations of the interaction of different materials. Other forms of construction that utilize interaction and are treated in this final report include sandwich construction, hybrid steel construction, prestressed steel structures and cable-stayed steel bridges.

COMPOSITE STEEL-CONCRETE CONSTRUCTION

The papers presented at the Ninth Congress by Messrs. Daniels (165), Hope-Gill (166), Maeda (167), Roderick (168), and Naka (169) made it clear that problems of continuity in composite structures are of major concern in current research. The remaining contributions dealing with the topic of composite

construction (170) (171) (172) (173) (174) were addressed to problems encountered in simple elements.

Composite Steel-Concrete Beams

Continuity - The use of composite beams in bridges and multi-story buildings brought forth a number of questions that became the subject of systematic research only during the last decade. The early static tests of continuous beams (54) (55) (56) (57) were followed by investigations of beam-to-column connections (166) (168) and by detailed investigations of the negative moment region of continuous beams (168) (175) (176) (177). Tests have shown that properly reinforced continuous composite beams can develop negative moments equal to the ultimate bending strength of their positive moment region. Furthermore, plastic hinges with adequate moment-rotation capacity can be developed under combined negative moment and shear. These studies furnished the basic tools for investigations of composite beams as part of building frames.

Continuity in frames requires reliable connections. This subject earlier had not received as much attention as it deserves. Dobruszkes, Janss and Massonnet (178) reported on tests of connections between composite beams and concrete columns, and between fully encased steel beams and columns. Roderick (168) briefly discussed tests on exterior and interior connections of composite beams to fully encased columns carried out by Ansourian at the University of Sydney. Naka, Wakabayashi and Murata (169) listed several references to tests of beam-to-column connections encased in reinforced concrete. All found that concrete encasement substantially increases the strength of a connection. An interesting type of a semi-rigid connection of a composite beam to a steel column was developed by Johnson and Hope-Gill (166). It offers many of the advantages of a rigid connection, but lower in-place cost. The connection can develop appreciable strain hardening before the maximum load of the continuous beam is attained.

Concurrent fatigue tests of continuous beams were aimed at bridge applications. Maeda and Kajikawa (167) investigated the fatigue strength of a tension flange with stud shear connectors. The tests, including both direct tension specimens and beams subjected to negative bending, indicated a substantial reduction of the tension flange fatigue strength in the presence of shear connectors. This reduction tended to be smaller in bending tests than in direct tension tests. These results were in good agreement with earlier tests (39) (179) (180). Roderick (168) tested a continuous composite beam in fatigue and concluded that the fatigue life of stud connectors compared favorably with the values given by the British Standard Code of Practice CP117: Part 2 (36). Fatigue strength of shear connectors in continuous composite beams had been investigated in an earlier study at Imperial College (35) and in extensive investigations at Lehigh University (37) (165).

To avoid the deleterious effect of connectors on the fatigue strength of tension flanges, it is a common United States practice

to omit shear connectors from a portion of, or throughout, the negative moment region of a continuous beam. The Lehigh investigations have shown that in such cases additional shear connectors must be provided near the points of contraflexure. The results of those studies have been incorporated in the AASHTO Specifications (118) (181). Further studies of the negative moment region carried out at Lehigh University (165) have shown that the longitudinal reinforcement in the slab over the negative moment region should be at least 1% of the cross-sectional area of the slab; that most of this reinforcement should be placed near the top surface of the slab; and that it is reasonable to assume that the effective width of the concrete slab is the same throughout the beam length. Similar conclusions have been reported by Tachibana (182).

Lightweight Concrete - The results of systematic tests of composite beams with lightweight concrete slabs at Lehigh University and at the University of Missouri, referred to in the introductory paper (164), were published in 1971 (25) (26) and incorporated in the AISC Specification (183). In addition to determining the strength of shear connectors, these studies have shown that the strength of a composite beam with a slab of lightweight concrete is the same as for a beam with a slab of ordinary concrete of the same compressive strength. On the other hand, deflections are larger in beams with lightweight concrete. Accordingly, the design requirements based on beam strength should depend only on the strength of concrete while the deflection requirements should be also a function of concrete density.

Static and fatigue tests of stud connectors embedded in lightweight concrete were made in Great Britain by Menzies (184), who recommended design values for concrete with densities from 87 to 143 lb/cu. ft. Further research on lightweight concrete composite beams was reported by Roderick (168), Janss (170) and Ypeij (185). These studies generally substantiated the results of the above-mentioned American investigations.

Creep and Shrinkage - Long-term static tests of composite beams with lightweight aggregates were conducted at the University of Missouri (26) and at the University of Liege (170). Both studies demonstrated substantial deflection increases from creep and shrinkage. The Missouri investigators recommended that, in design, time-dependent deflection be taken as equal to instantaneous deflection.

Other studies of creep effects have been made recently in Germany by Hasse (186) and by Mainz and Wolff (187). In Great Britain, Menzies (188) analyzed data from the Moat Street Flyover taken during construction and for about two years thereafter. He found that after construction, effects of temperature changes obscured the small effects caused by shrinkage and creep. In the United States, Roll (189) analyzed the stresses and deflections due to differential shrinkage and creep in both shored and unshored beams in a New York State office building. He obtained excellent correlation between measured and theoretical deflections.

Precast Slabs - Composite beams with precast slabs connected to the steel members with high-strength bolts can be advantageous, particularly when on-site construction must be kept to a minimum or when traffic must be maintained during construction. In addition to Sattler (43), this type of construction was pioneered by Faltus (190) who used it for elevated railway bridges built in Czechoslovakia in the early sixties.

Marshall, Nelson and Banerjee (191) have continued Sattler's work on the use of high-strength bolts by making a series of push-out and beam tests at the University of Glasgow. They concluded that the load at first slip can be estimated using a friction coefficient of 0.45 for precast slabs on steel. A higher coefficient can be used for cast-in-place slabs. Beck and Heunisch (192) also made push-out and beam tests and concluded that design should be based either on an allowable coefficient of friction or on forces redistributed by slip. Research at Purdue University (45) (193) demonstrated that it is feasible to replace deteriorated highway bridge decks with precast, prestressed concrete slabs.

Beck and Heunisch (192) used bolted precast slabs in the construction of a 7-story building at Johann Wolfgang Goethe University in Frankfurt-on-Main. Other structures utilizing this type of composite construction included a few demountable overpasses and parking garages. Holloway (194) (195) described the Rosslare Harbor Viaduct and the Tivoli Bridge in Ireland as examples of structures reconstructed economically with precast composite units.

Miscellaneous - Among numerous additional studies, the load factor design for highway bridges developed on both sides of the Atlantic (196) (181) (197) (198) includes provisions for design of composite beams. Reddy and Hendry (199) made a thorough review of the results of British studies of simply-supported composite beams and derived equations for the ultimate bending strength of such beams. Repeated load tests of simple composite beams by Roderick (168) demonstrated that properly designed composite beams will not fail catastrophically, but rather by gradual deterioration. R. P. Johnson proposed design methods for consideration of longitudinal shear (200), transverse slab reinforcement (201) and deep haunches (202) in composite beams; the last proposal was based on experiments conducted at the University of Manchester (203). New studies of torsional properties of composite beams were reported by Heins and Kuo (204) (205). Janss joined the researchers interested in the use of checker plate (170) and L'Hermite joined those interested in the use of epoxy resins (173) for shear connection. Naraharirao (206) and Cran (207) reported on further studies of composite open-web steel joists.

Concrete Encased Steel Beams

Interest in concrete encased steel beams appears to be limited. Only one reference (169) to such beams was made in the contributions to the Ninth Congress, and only four other new references were found (194) (195) (208) (209).

According to Naka, Wakabayashi and Murata (169), steel frames encased in reinforced concrete are used extensively in Japan because of their excellent seismic resistance. Encased steel beams are an integral part of such frames. Their design is governed by the specifications of the Architectural Institute of Japan (210) and is based on extensive studies listed in the bibliography of Reference 169. The allowable bending moment for an encased steel beam is specified as the sum of the allowable bending moments of the steel beam and the reinforced concrete beam. Holloway reported on the use of precast concrete-encased steel beams in a footbridge at Balbriggan (195) and as parapet units for the Tivoli Bridge (194). The remaining two references were concerned with tests of concrete encased steel sections. Matty and Narasimhan (208) tested 24 simply-supported and 5 continuous beams to determine their moment-curvature relationships. Babb (209) reported on full-scale and model tests on two new, patented types of concrete encased steel sections.

Steel-Concrete Columns

The discussion of concrete encased steel columns in the introductory report (164) was concluded with the following statement: "It would seem...that the data and the tools necessary for the development of improved design methods for concrete encased steel columns are available and that improvements of code provisions are in order." The 1971 edition of the ACI Building Code (211) is available and a new British Standard CP117: Part 3 (212) is in draft form. Both include new design methods for steel-concrete columns.

Based on experimental and theoretical research by Furlong (107) (108) and by Knowles and Park (213) (214), the 1971 edition of the ACI Building Code redefined all types of composite columns as composite compression members reinforced longitudinally by either structural steel shapes, pipe or tubing with or without longitudinal reinforcing bars. Composite compression members now can be designed as beam-columns; prior to the 1971 Code rules were available only for the design of concentrically loaded columns. Subject to limitations on maximum stiffness and maximum radius of gyration of the composite cross-section, and to a few detailing rules, the strength of composite compression members is computed using the ordinary procedures for reinforced concrete members.

Following the decision in 1963 to use concrete-filled tubular columns in the multilevel interchange between the M4 and M5 Motorways at Almondsbury (215), exploratory tests were conducted at the Building Research Station and Imperial College. As has been reported in the introductory report, further investigations followed at Imperial College. These included analytical work that was checked against tests of concrete-filled circular tubes conducted at Imperial College (216), in Japan (217) and at Liege (218). A second series of tests at Liege (219) permitted a check of the analytical work for eccentrically loaded square and rectangular concrete-filled tubes. A computer program based on uniaxial strength of concrete was found to predict accurately the strength of the latter columns and the strength of slender circular columns with length-to-diameter ratios over 15 (220). More

recent studies at Imperial College have been concerned with triaxial stress effects that augment the strength of short circular concrete-filled tubes (221). Another such attempt was reported by Janss (170).

The practical utilization of the research at Imperial College took three paths. The uniaxial computer program was used both to generate ultimate load tables for concrete-filled tubes (222) and to develop an empirical method for calculating the ultimate strength of concrete-filled square and rectangular columns (223). Finally, a draft was prepared of a design specification for composite columns in buildings and bridges (212).

In Japan, steel columns encased in reinforced concrete are used in frames (169). The allowable axial load and bending moment are computed either (1) as the allowable axial load on the concrete section and the sum of the allowable moments on the steel and concrete sections or (2) as the allowable moment on the steel section and the sum of the allowable axial loads on the steel and concrete sections.

Roderick (168) reported the results of tests of concrete encased steel columns bent about both principal axes. In nearly all tests the theoretical column instability was reached shortly after the steel had begun to yield. The theoretical collapse loads were lower than the actual collapse loads for eccentricities of up to 0.8 in. about any centroidal axis. Good agreement with the theoretical solution was found also in tests of concrete-filled square steel tubes eccentrically loaded about their diagonal axis.

The development of two additional computer programs for concrete-filled tubular beam-columns was reported recently from Canada (224) and the United States (225). Another paper discussed prestressing of tubular columns through the use of expansive cement (226).

Two earlier studies of concentrically loaded concrete-filled tubes (227) (228) were discussed in the introductory report, but the corresponding references were omitted from the bibliography.

Steel-Concrete Slabs

The developmental work leading to the use of composite steel-concrete plates as blast resistant hatch covers, mentioned in the introductory report, is described in Reference 229. Composite steel-concrete plates are also well suited for mine shaft and tunnel liners (230) (231). While ordinarily the concrete and steel connection is mechanical, L'Hermite (173) proposed to bond the two with epoxy resin applied to blast-cleaned steel plates just before placing the concrete. In these applications, the steel plate serves both as a tension or shear carrying member and a concrete form.

A brief, interesting history of the development and current status of cellular steel floors was presented by Dallaire (232). The interaction of composite sheet steel flooring with concrete

has been under investigation at the University of Iowa (134) (233). The behavior of these systems was described by Schuster (172) for simple one-way slabs and by Porter and Ekberg (171) for simply supported two-way slabs.

Composite Steel-Concrete Structures

Since the individual elements, i.e. beams, columns, slabs and walls of a structure may be composite or noncomposite and, furthermore, of several different types, the choice of possible structural systems is substantial.

In bridge construction, the most common structural system is a steel beam and girder framing acting compositely with a concrete slab.

In building construction, the older fully encased steel framing and the newer unencased steel framing acting compositely with the floors are probably the two best known systems. As we have seen earlier, a modification of the fully encased framing is used extensively in Japan (169) because of its excellent seismic resistance. Unencased steel framing acting compositely with the floors is used extensively in the United States. Roderick's studies of connections (168) suggest the use of fully encased columns in combination with ordinary unencased composite beams. A similar system was developed recently by F. R. Khan for medium-rise tall buildings (234). In this system, the gravity loads are supported by steel columns, both exterior and interior, while the wind loads are resisted by exterior concrete walls reinforced with the exterior steel columns and acting as a vertical box cantilever. The exterior columns are encased in concrete walls. In the three buildings discussed in Reference 234, the floors were of ordinary steel-concrete composite construction. The buildings, located in Houston, Chicago and New Orleans, are 24, 36 and 50 stories high.

SANDWICH CONSTRUCTION

None of the contributions to Theme IIa dealt with sandwich panels and only one (235) among the numerous other contributions to the Ninth Congress dealt with sandwich construction. It would seem then that there is little interest in the use of sandwich plates as structural construction elements. However, some recent references suggest that the interest is not entirely absent, either in Europe (235) or in the United States (236).

Several recent articles by Jungbluth (235) (237) (238) described the properties, manufacture and applications of steel-polyurethane sandwich panels that consist of two steel sheet face plates and a comparatively thick core of foamed polyurethane. The principal use of the panels is for walls but they have been used or proposed for use as a self-supporting roof and for cable-supported roofs. Reichard (236) discussed paper honeycomb-core panels used by the building industry for walls of

single-story residences. The panels are faced with steel, aluminum, fiber-reinforced plastics or other materials. The article concluded with the statement that the construction industry in the U.S. is now using several different sandwich panel systems and is contemplating the use of others.

HYBRID STEEL CONSTRUCTION

Two contributions to the discussion were concerned with hybrid sections. In one, Bo and Daddi (174) pointed out that unsymmetrical hybrid sections with bottom flanges made of 100 ksi yield steel would improve Preflex beams. The other paper presented an analysis and four tests of hybrid columns (239) with 100 or 50 ksi steel flanges and 50 or 36 ksi steel webs.

The results of the hybrid girder fatigue tests at the University of Texas, referred to in the introductory report, have been published (240) (241) (242). The reports contain information on fatigue tests of 71 plate girders having stiffened webs 3 or 4 feet deep of 36 ksi steel and flanges of 100 or 50 ksi steels.

The use of hybrid girders in the United States has grown rapidly since the 1969 adoption of specifications for their design (84) (118). Today, hybrid girders with 50 ksi flanges and 36 ksi webs are used extensively for highway bridges. The discussion provided no information on the use, if any, of hybrid girders in other countries. On the other hand, hybrid construction, i.e. the use of different steels in various parts of the same structure, has been common for decades. Structures of this type can be found throughout the world. The recent development of new steels has increased the importance of hybrid construction and widened its use.

PRESTRESSED STEEL STRUCTURES

For this discussion, it seems useful to distinguish between prestressing of individual components (e.g. a girder) and prestressing of the whole structure (e.g. a cable-supported roof).

Two contributions were directed to the first subject. Bo and Daddi (174) proposed to build Preflex beams using hybrid girders with bottom flanges of 100 ksi steel. In the second contribution, Tochacek, Rosenkranz and Ferjencik (243) outlined an extensive research and development of prestressed steel that has been in progress since 1960 in Czechoslovakia. One recent news item (244) dealing with prestressed elements is pertinent here. It reports the first -- and thus far the only -- use of Preflex beams in the United States; this type of construction was selected primarily to reduce construction depth.

The scarcity of Western literature on this subject suggests that prestressed steel components have been used there only infrequently, probably because they do not offer an economic advantage. On the other hand, the literature cited in the introductory report and the contribution by Tochacek, Rosenkranz and Ferjencik suggest that prestressed steel components are used in Eastern Europe.

One contribution to Theme IIa dealt with prestressing of steel structures (245). Describing examples of prestressed steel structures built in Czechoslovakia, it included, among others, cable-supported roofs, strengthening of existing bridges by prestressing, cable-supported pipe crossings and guyed towers. Further information on this general subject may be found in Reference 246. It should be mentioned that Theme IIIa of the Ninth Congress was devoted specifically to the subject of cable-supported roofs and the contributions to that subject covered more than 100 pages of the Preliminary Report (247). Five other contributions to various themes in the same Report dealt with cable-stayed bridges. Recent papers covering these and other types of prestressed steel structures are too numerous to be included in this final report.

Prestressing of steel structures is a widely used art that includes many varied forms. It is noteworthy, however, that East European countries treat it as a separate, distinct discipline.

CABLE-STAYED STEEL BRIDGES

The subject of cable-stayed bridges was introduced in Theme IIa by reference to six earlier papers and in Theme IIIa by Professor Leonhardt's introductory paper (248). Outlining recent trends and further developments, Leonhardt pointed out several advantages of cable-stayed bridges as compared to suspension bridges. He concluded that cable-stayed bridges are particularly suitable for spans in excess of 1,000 meters and may even be used for spans of 1,500 meters in the future. Leonhardt suggested also that there is a trend toward a large number of cables in one plane; that the use of aerodynamically stable deck cross-sections is particularly desirable for long spans; that parallel wire cables increase stiffness and reduce weight; and that a newly developed process of socketing with plastics instead of zinc will increase the fatigue strength of cables and lead to higher working stresses. In his discussion (249), Thul expressed general agreement with Leonhardt's views. However, Thul expects suspension bridges to remain dominant in very long spans. Thul's discussion of cable properties, socketing and delayed cracking of wires was a particularly useful contribution. Other contributions to the Ninth Congress included discussions of: a cable-stayed bridge with a three-level deck (250); the construction of the bridge over the railroad station in Ludwigshafen (251); the investigation of the aerodynamic behavior of the Toyosato Ohhashi bridge in

Japan (252); and another method of socketing and protecting parallel wire cables (253). Additional information on cable properties can be found in Reference 254.

It is interesting that, with one exception, all contributions pertaining to cable-stayed bridges were authored by German engineers. On the other hand, a review of the recently published reports indicates that cable-stayed bridges are receiving considerable attention throughout the world. General surveys have been published in India (255), the United States (256) and elsewhere (257). Numerous articles have described new bridges in Great Britain (258), Canada (259), Australia (260), Czechoslovakia (261), the Soviet Union (262), the United States (263), France (133), Germany (264), Austria (265), Argentina (266) and elsewhere; and plans for new bridges (267) (268) (269) (270). Contributions to the theory of design are also multinational (271) (272) (273) (274) (275) (276) (277) (278) (279) (280) (281). It also should be pointed out that some of the articles on cable-stayed bridges deal with problem areas (249) and a catastrophic failure (282) (283) (284) (285). Report 282 made it clear, however, that this failure was unrelated to the cable-stayed feature of the bridge.

This brief review of the recent contributions to the field of cable-stayed steel bridges has highlighted one of the most significant structural developments of recent years: the spread of this construction throughout the world. Counting bridges that have been completed and those now under construction, there are presently more cable-stayed steel bridges outside than inside the German Federal Republic. This development alone is bound to lead to further innovations that will make the cable-stayed steel bridge an even more effective tool of the bridge builder.

CONCLUDING REMARKS

This survey would appear incomplete unless it included at least a thought or two on what the past suggests for the future.

In building construction we can expect more complete integration of the components into systems. In low-rise structures, walls and floors will be integrated into room modules before they are brought to the site. In high-rise structures, the development of submodules can be predicted from recent experience. Frames will probably be integrated with curtain walls to serve both as a structure and a temperature and sound barrier. This subsystem may also include electrical and mechanical services. Floors, ceilings, wiring and ducts are candidates for another subsystem.

In bridge construction we can expect to see extensive use of single-span preassembled bridges for short spans. In medium spans, one or two girders with an appropriate portion of the slab are likely to be subassembled before lifting the unit into

place. Transverse and longitudinal continuity can be provided through prestressing or some other means. In the long span range, we have already seen full-width modules lifted in place, joined longitudinally and supported by cable stays or suspended from cables.

The development of improved materials and better design tools will lead not only to more economy, but also to more useful structures. As in the past, the structures of the future will play an important part in improving the quality of life.

BIBLIOGRAPHY

For brevity, the following abbreviations have been used in this bibliography:

ACI	American Concrete Institute
AISC	American Institute of Steel Construction
AISI	American Iron and Steel Institute
AASHO	American Association of State Highway Officials
ASCE	American Society of Civil Engineers
IABSE	International Association for Bridge and Structural Engineering

Papers referenced by numbers lower than 164 are listed in the bibliography of the introductory report (164). Only those references from the introductory report that needed correction have been included in the following list.

20. "Specification for the Design, Fabrication and Erection of Structural Steel for Buildings," AISC, 1963.
25. Ollgaard, Slutter and Fisher, "Shear Strength of Stud Connectors in Lightweight and Normal Weight Concrete," AISC Engineering Journal, April 1971.
26. McGarraugh and Baldwin, "Lightweight Concrete-on-Steel Composite Beams," AISC Engineering Journal, July 1971.
63. McManus and Culver, "Nonuniform Torsion of Composite Beams," ASCE Journal of the Structural Division, June 1969.
131. Johnson, R. P., "Research on Composite Steel-Concrete Beams, 1960-1968," ASCE Journal of the Structural Division, March 1970.
142. Aleksandrov, Bryukker, et. al., "Raschet Trekhsloynnykh Panely," Gosudarstvennoye Naucho-Tekhnicheskoye Izdatel' stvo, Oborongiz, Moskva, 1960.
146. Smolenski and Krokosky, "Optimal Multifactor Design Procedure for Sandwich Panels," ASCE Journal of the Structural Division, April 1970.
154. Cran, J. A., "Developments in Sandwich Panels," Symposium on Panelized Building Systems, Sir George Williams University, Montreal, 1970.
155. McCavour, T. C., "Frameless Industrialized Steel Building Systems," Symposium on Panelized Building Systems, Sir George Williams University, Montreal, 1970.
164. McDevitt and Viest, "Interaction of Different Materials," Introductory Report, Ninth Congress IABSE, Amsterdam, 1972.
165. Fisher, Daniels and Slutter, "Continuous Composite Beams for Bridges," Preliminary Report, Ninth Congress IABSE, Amsterdam, 1972.

166. Johnson and Hope-Gill, "Semi-Rigid Joints in Composite Frames," Preliminary Report, Ninth Congress IABSE, Amsterdam, 1972.
167. Maeda and Kajikawa, "Fatigue Strength of Steel Plates with a Stud Shear Connector for Application to Continuous Composite Beams," Preliminary Report, Ninth Congress IABSE, Amsterdam, 1972.
168. Roderick, J. W., "Further Studies of Composite Steel and Concrete Structures," Preliminary Report, Ninth Congress IABSE, Amsterdam, 1972.
169. Naka, Wakabayashi and Murata, "Steel-Reinforced Concrete Construction," Preliminary Report, Ninth Congress IABSE, Amsterdam, 1972.
170. Janss, J., "Developpement des recherches concernant les constructions mixtes executees par le C. R. I. F. a l'Universite de Liege," Preliminary Report, Ninth Congress IABSE, Amsterdam, 1972.
171. Ekberg and Porter, "Summary of Full-Scale Laboratory Tests of Concrete Slabs Reinforced with Cold-Formed Steel Decking," Preliminary Report, Ninth Congress IABSE, Amsterdam, 1972.
172. Schuster, R. M., "Composite Steel-Deck-Reinforced Concrete Systems Failing in Shear-Bond," Preliminary Report, Ninth Congress IABSE, Amsterdam, 1972.
173. L'Hermite, R., "Utilisation des colles dans le beton arme. Le beton plaque," Preliminary Report, Ninth Congress IABSE, Amsterdam, 1972.
174. Bo and Daddi, "Prestressed Composite Hybrid Beams," Preliminary Report, Ninth Congress IABSE, Amsterdam, 1972.
175. Ghosh and Mallick, "Contribution of Longitudinal Reinforcement to the Ultimate Strength of Composite Sections under Hogging Moment," Indian Concrete Journal, August 1970.
176. Johnson and Willmington, "Vertical Shear Strength of Compact Composite Beams," Proceedings, Institution of Civil Engineers, January 1972.
177. Climenhaga and Johnson, "Moment-Rotation Curves for Locally Buckling Beams," ASCE Journal of the Structural Division, June 1972.
178. Dobruszkes, Janss and Massonnet, "Experimental Researches on Steel Concrete Frame Connections, 1st Part: Frame Connections Comprising Concrete Columns and a Composite Beam. 2nd Part: Frame Connections Completely Encased in Concrete," IABSE, Publication 29-II, 1969.
179. Wakabayashi, Sawano and Naruoka, "Tensile Fatigue Tests of Plates with a Stud Shear Connector," The Bridge and Foundation Engineering, No. 4, 1971.
180. Roshardt, W., "Einfluss des Aufschweissens von Bolzen auf das Grundmaterial," Schweizerische Bauzeitung, No. 51, 1966.
181. "Interim Specifications 1971," AASHO, 1971.
182. Tachibana, Y., "Experiment on Non-Prestressed Continuous Composite Beams," IABSE, Publication 30-I, 1970.
183. "Supplement No. 2 to the Specification for the Design, Fabrication and Erection of Structural Steel for Buildings," AISC, December 1971.
184. Menzies, J. B., "CP 117 and Shear Connectors in Steel-Concrete Beams Made with Normal Density or Lightweight Concrete," The Structural Engineer, March 1971.
185. Ypeij, E., "New Developments in Dutch Steel Bridge Building," Preliminary Report, Ninth Congress IABSE, Amsterdam, 1972.
186. Hasse, G., "Auswirkung des Kriechens bei Statisch Unbestimmten Verbundstabwerken mit Abgestuften Querschnitten," Verein Deutscher Ingenieure, Berichte, November 1969.
187. Mainz and Wolff, "Zur Berechnung von Spannungsumlagerungen in Statisch Unbestimmten Stahlverbundtragwerken," Der Stahlbau, February 1972.
188. Menzies, J. B., "Structural Behavior of the Moat Street Flyover, Coventry," Civil Engineering and Public Works Review, September 1968.
189. Roll, F., "Effects of Differential Shrinkage and Creep on a Composite Steel-Concrete Structure," ACI Special Publication SP 27-8, 1971.

190. Faltus, F., "Nouveaux Projects pour la Construction des Ponts en Tchecoslovaquie," *Acier-Stahl-Steel*, No. 5, 1964.
191. Marshall, Nelson and Banerjee, "An Experimental Study of the Use of High-Strength Friction-Grip Bolts as Shear Connectors in Composite Beams," *The Structural Engineer*, April 1971.
192. Beck and Heunisch, "Zum Reibungsverbund Zwischen Stahl und Betonfertigteilen bei Dubellosen Verbundkonstruktionen," *Der Stahlbau*, February 1972.
193. Gutzwiller, Lee and Scholer, "Precast, Prestressed Concrete for Bridge Decks," *Highway Research Board*, Special Report 116, 1971.
194. Holloway, R. T., "Prefabricated Composite Units of Structural Steel and Concrete," *Proceedings, Institution of Civil Engineers*, June 1970.
195. Holloway, R. T., "Precast Composite Sections in Structures," *ACI Journal*, February 1972.
196. Vincent, G. S., "Tentative Criteria for Load Factor Design of Steel Highway Bridges," *AISI Steel Research for Construction Bulletin* No. 15, March 1969.
197. Hansell and Viest, "Load Factor Design for Steel Highway Bridges," *AISC Engineering Journal*, October 1971.
198. Flint and Edwards, "Limit State Design of Highway Bridges," *The Structural Engineer*, March 1970.
199. Reddy and Hendry, "Ultimate Strength of a Composite Beam Allowing for Strain Hardening," *Indian Concrete Journal*, September 1970.
200. Johnson, R. P., "Longitudinal Shear Strength of Composite Beams," *ACI Journal*, June 1970.
201. Johnson, R. P., "Transverse Reinforcement in Composite Beams for Buildings," a precis of a paper (Reference X(30) filed in the Institute's Library. *The Structural Engineer*, May 1971.
202. Johnson, R. P., "Design of Composite Beams with Deep Haunches," *Proceedings, Institution of Civil Engineers*, January 1972.
203. Taylor, Plum and Papasozomenos, "Investigation on the Use of Deep Haunches in Composite Construction," *Proceedings, Institution of Civil Engineers*, September 1970.
204. Heins and Kuo, "Composite Beams in Torsion," *ASCE Journal of the Structural Division*, May 1972.
205. Heins and Kuo, "Torsional Properties of Composite Girders," *AISC Engineering Journal*, April 1972.
206. Naraharirao, S., "Composite Open-Web Steel Joists," *Journal of Inst. Eng. (India), Civil Engineering Division*, July 1970.
207. Cran, J. A., "Design and Testing Composite Open Web Steel Joists," *Proceedings of First Specialty Conference on Cold-Formed Steel Structures*, University of Missouri - Rolla, 1971.
208. Matty and Narasimhan, "Plastic Rotations in Composite Beams," *Journal of the Inst. Eng. (India), Civil Engineering Division*, May 1970.
209. Babb, A. S., "Stress Analysis of Steel Composite Structures," *The Structural Engineer*, August 1970.
210. "AIJ Standard for Structural Calculation of Steel-Reinforced Concrete Structures," *Architectural Institute of Japan*, 1963.
211. "Building Code Requirements for Reinforced Concrete, ACI 318-71," *ACI*, 1971.
212. CP117: Part 3, "Composite Construction in Structural Steel and Concrete - Columns in Buildings and Bridges," *British Standards Institute* (in preparation).
213. Knowles and Park, "Strength of Concrete Filled Steel Tubular Columns," *ASCE Journal of the Structural Division*, December 1969.

214. Knowles and Park, "Axial Load Design for Concrete Filled Steel Tubes," ASCE Journal of the Structural Division, October 1970.
215. Kerensky and Dallard, "The Four-Level Interchange between M4 and M5 Motorways at Almondsbury," Proceedings, Institution of Civil Engineers, July 1968.
216. Neogi, P. K., "Concrete Filled Tubular Columns," PhD Thesis, University of London, 1967.
217. Kato and Kanatarin, "Experimental Studies on Concrete-Filled Tubular Columns," Steel Structures Laboratory Report, Tokyo University, October 1966.
218. Janss, J., "Composite Steel-Concrete Construction Part 3. Tests on Concrete Filled Tubular Columns," Center of Scientific Research and Industrial Fabrication (CRIF), Brussels.
219. Guiaux and Dehouse, "Tests on 22 Eccentrically-Loaded Square and Rectangular Concrete-Filled Tubular Columns," Laboratoires d'Essais des Constructions du Genie Civil et d'Hydraulique Fluviale, University of Liege, Test Report No. R766, September 1968.
220. Sen, H. K., "Concrete-Filled Tubular Steel Columns," Tubular Structures, British Steel Corporation, Tubes Division, November 1970.
221. Sen, H. K., "Triaxial Effects in Concrete-Filled Tubular Steel Columns," PhD Thesis, University of London, July 1969.
222. "Concrete-Filled Hollow Section Steel Columns Design Manual," Structural Marketing Department, British Steel Corporation, Tubes Division, London.
223. Basu and Somerville, "Derivation of Formulae for the Design of Rectangular Composite Columns," Proceedings (Supplement V), Institution of Civil Engineers, 1969.
224. Gardner, N. J., "Design of Pipe Columns," Engineering Journal, Engineering Institute of Canada, March 1970.
225. Chen and Chen, "Analysis of Concrete-Filled Steel Tubular Beam - Columns," FEL Report No. 370.10, Lehigh University, 1970.
226. Bertero and Moustafa, "Steel-Encased Expansive Cement Concrete Column," ASCE Journal of the Structural Division, November 1970.
227. Kloppel and Goder, "Traglastversuche mit ausbetonierteon Stahlrohren und Aufstellung einer Bemessungsformel," Der Stahlbau, January and February 1957.
228. Salani and Sims, "Behavior of Mortar Filled Steel Tubes in Compression," ACI Journal, October 1964.
229. Albritton, G. E., "Deep Slabs Subjected to Static and Blast Loading," ASCE Journal of the Structural Division, November 1969.
230. Link, H., "Watertight Shafting Lining of Combined Concrete and Steel-Plate Construction for a Canadian Potash Mine Shaft," The Canadian Mining and Metallurgical Bulletin, July 1971.
231. "British Tunnel Features Steel-lined Precast Liner," Civil Engineering, February 1972.
232. Dallaire, E. E., "Cellular Steel Floors Mature," Civil Engineering, July 1971.
233. Porter and Ekberg, "Investigation of Cold-Formed Steel Deck-Reinforced Concrete Floor Slabs," Proceedings of First Specialty Conference on Cold-Formed Steel Structures, University of Missouri-Rolla, August 1971.
234. "Building Design Reduces Steel with Concrete-Tube Wind Bracing," Engineering News Record, June 3, 1971.
235. Jungbluth, O., "Weitgespannte Sandwichkuppel im Werkstoffverbundsystem Stahlfeinblech-Polyurethanschaum," Ninth Congress IABSE, Preliminary Report, Amsterdam, 1972.

236. Reichard, T. W., "Paper Honeycomb Sandwich Panels as Lightweight Structural Components," National Bureau of Standards, Building Science Series 43, Washington, D. C., 1972.
237. Jungbluth, O., "Sandwich Plachentragwerke im Stahlbau," Eighth Congress IABSE, Final Report, New York, 1968.
238. Jungbluth, O., "Steel/Plastic Sandwich Structures - A New Building Technique," *Plastica*, No. 12, 1970.
239. Tebedge, Nadig and Tall, "Strength of Hybrid Steel Columns," Preliminary Report, Ninth Congress IABSE, Amsterdam, 1972.
240. Toprac, A. A., "Fatigue Strength of Hybrid Plate Girders," *Welding Journal - Welding Research Supplement*, May 1969.
241. Toprac and Fielding, "Fatigue Tests of A441 - A36 Hybrid Plate Girders," *The Structural Engineer*, December 1970.
242. Toprac and Natarajan, "Fatigue Strength of Hybrid Plate Girders," *ASCE Journal of the Structural Division*, April 1971.
243. Tochacek, Rosenkranz and Ferjencik, "Czechoslovak Research in the Area of Prestressed Metallic Structures," Preliminary Report, Ninth Congress IABSE, Amsterdam, 1972.
244. "Bridge Has Prestressed Girders in Concrete," *Engineering News Record*, December 3, 1970.
245. Ferjencik and Tochacek, "Tschechoslowakische Realisationen auf dem Gebiete vorgespannte Metallkonstruktionen," Preliminary Report, Ninth Congress IABSE, Amsterdam, 1972.
246. Brodka and Klobukowski, "Vorgespannte Stahlkonstruktionen," *Wilhelm Ernst & Sohn*, Berlin, Munich and Dusseldorf, 1969.
247. Preliminary Report, Ninth Congress IABSE, Amsterdam, 1972.
248. Leonhardt, F., "Seilkonstruktionen und seilverspannte Konstruktionen," Introductory Report, Ninth Congress IABSE, May 1972.
249. Thul, H., "Schragseilbrucken," Preliminary Report, Ninth Congress, May 1972.
250. Steinhardt, O., "Schragkabelbrücke mit drei Fahrbahnen übereinander," Preliminary Report, Ninth Congress IABSE, May 1972.
251. Boue and Gepp, "Brückenmontage nach der Schubladenmethode," Preliminary Report, Ninth Congress IABSE, Amsterdam, 1972.
252. Konishi, Komatsu and Inque, "Aerodynamic Behavior of The Cable Stayed Bridge Toyosato Ohhashi," Preliminary Report, Ninth Congress IABSE, May 1972.
253. Finsterwalder and Finsterwalder, "Neue Entwicklung von Paralleldrahtseilen für Schragseil- und Spannbandbrücken," Preliminary Report, Ninth Congress IABSE, May 1972.
254. Scalzi and McGrath, "Mechanical Properties of Structural Cables," *ASCE Journal of the Structural Division*, December 1971.
255. Tamhankar, M. G., "Design of Cable-Stayed Girder-Bridges," *Journal Indian Roads Congress*, May 1970.
256. Podolny and Fleming, "Historical Development of Cable-Stayed Bridges," *ASCE Journal of the Structural Division*, September 1972.
257. Feige and Klaus, "Long-Span Steel Highway Bridges Today and Tomorrow," *Acier-Stahl-Steel*, May 1971.
258. Kerensky, Henderson and Brown, "The Erskine Bridge," *The Structural Engineer*, April 1972.
259. Demers and Simonsen, "Montreal Boasts Cable-Stayed Bridge," *Civil Engineering*, August 1971.
260. "Inclined Tower Bridges," *Consulting Engineer (London)*, June 1969.
261. "Barges Place Box Girder Units for Long Cable-Stayed Reach," *Engineering News Record*, September 2, 1971.

262. Kazimirov and Kireenko, "New Trends in the Development of Welded Span Structures for Motorway Bridges," *Welding Production*, No. 5, 1971.
263. "First U. S. Stayed Girder Span is a Slim, Economical Crossing," *Engineering News-Record*, June 29, 1972.
264. Daniel, Von H., "Die Rheinbrücke Duisburg-Hevenkamp Planung, Bauwettbewerb und seine Ergebnisse," *Der Stahlbau*, July 1971 and January 1972.
265. Schlauss, K., "Der Fussgängersteg Raxstrasse In Wieh," *Stahlbau Rundschau*, February 1970.
266. "Bridge Builder Leaves \$21 Million on the Table," *Engineering News-Record*, March 18, 1971.
267. "The Largest Complex of Bridge Works in Europe," *Acier-Stahl-Steel*, October 1970.
268. "Private French Firms to Build Record Cable-Stayed Bridge," *Engineering News-Record*, December 3, 1970.
269. Seim, Larsen and Dang, "Analysis of Southern Crossing Cable-Stayed Girder," ASCE National Structural Engineering Meeting, April 1971.
270. "Pair of Record Spans May Carry New Orleans Bypass," *Engineering News-Record*, May 6, 1971.
271. Smith, B. S., "The Single-Plane Cable-Stayed Girder Bridge: A Method of Analysis Suitable for Computer Use," *Proceedings, Institution of Civil Engineers*, May 1967.
272. Smith, B. S., "A Linear Method of Analysis for Double-Plane-Cable-Stayed Girder Bridges," *Proceedings, Institution of Civil Engineers*, January 1968.
273. Maeda and Hayashi, "Analysis of General Forms of Cable-Stayed Girder Bridge," *Transactions, Japan Society of Civil Engineers*, December 1968.
274. Maeda and Hayashi, "Study on Static Structural Characteristics for Cable-Stayed Girder Bridges with a Three-Span Continuous Beam as Their Principal System," *Proceedings, Japan Society of Civil Engineers*, March 1970.
275. Wardlaw and Ponder, "Example of the Use of Wind Tunnels for Investigating the Aerodynamic Stability of Bridges," *Canada, National Research Council, Quarterly Bulletin Report DME/NAE 3*, 1969.
276. Murakami and Okubo, "Wind Resistant Design of a Cable-Stayed Girder Bridge," *Final Report, Eighth Congress IABSE*, New York, 1968.
277. Troitsky and Lazar, "Model Analysis and Design of Cable-Stayed Bridges," *Proceedings, Institution of Civil Engineers*, March 1971.
278. Tang, M. C., "Analysis of Cable-Stayed Girder Bridges," *ASCE Journal of the Structural Division*, May 1971.
279. Podolny, Jr., W., "Static Analysis of Cable-Stayed Bridges," *PhD Thesis, University of Pittsburgh*, 1971.
280. Baron and Lien, "Analytical Studies of Cable-Stayed Girder Bridges," *Proceedings, National Symposium on Computerized Structural Analysis and Design, George Washington University, Washington, D. C.*, 1972.
281. Lazar, B. E., "Stiffness Analysis of Cable-Stayed Bridges," *ASCE Journal of the Structural Division*, July 1972.
282. Rixson, C. H., "Report of Royal Commission into the Failure of West Gate Bridge," *Government Printer, Melbourne, Australia*, 7073/71.
283. "Australian Bridge Collapse Pinned on Designers," *Engineering News-Record*, August 12, 1972.
284. Kozak and Seim, "Structural Design Brings West Gate Bridge Failure," *Civil Engineering*, June 1972.
285. "West Gate Bridge Erection will Resume with Changes," *Engineering News Record*, March 2, 1972.

SUMMARY

This final report, combined with the introductory report on interaction of steel with other materials, constitutes a survey of the state-of-the-art in composite steel concrete construction, sandwich construction, hybrid steel construction, prestressed steel structures and cable-stayed bridges as of the middle of 1972.

RESUME

Ce rapport final forme, ensemble avec le rapport introductif sur l'interaction de l'acier avec d'autres matériaux, un aperçu sur l'état actuel de la construction en acier-béton, de la construction sandwich, la construction hybride, les structures en acier précontraint ainsi que des ponts à haubans, vers le milieu de l'année 1972.

ZUSAMMENFASSUNG

Dieser Schlussbericht bildet zusammen mit dem Einführungsbericht über die Wechselwirkung von Stahl mit anderen Materialien eine Uebersicht über den Stand des Stahlbetonbaues, der Sandwichkonstruktion, des hybriden und vorgespannten Stahlbaues sowie der Schrägkabel-Brücken um die Mitte des Jahres 1972.

Leere Seite
Blank page
Page vide

II b

Interaction entre différents éléments

Wechselwirkung zwischen verschiedenen Konstruktionsgliedern

Interaction of different Structural Elements and Assemblies

Leere Seite
Blank page
Page vide

DISCUSSION LIBRE • FREIE DISKUSSION • FREE DISCUSSION

The Design of Steel Buildings taking Account of the Sheeting

Projets des constructions en acier, compte tenu du revêtement

Entwurf von Stahlbaukonstruktionen unter Berücksichtigung
der Verkleidung

ÅKE HOLMBERG
D.Sc., Civ. and Struct. Eng.
Sweden

In their contribution, published in the preliminary report Mr Bryan and Mr Mohsin describe a test made on a model house with stiff gables, frames between them and corrugated steel sheets as a roof cooperating with the gables and the frame. They give calculated load distribution and observed load distribution so that the way of interaction between frames and sheeting is described.

As a complement to what is given in the report I shall mention here some simple facts.

The bare frames are deformed individually. Load acting on one of them gives deformations in this one only. Thus the frames may be looked upon as an elastic foundation of the Winkler-type carrying the sheeting. The sheeting itself may be looked upon as a shear-weak beam and thus the whole problem is formulated as that of a shear-weak beam on an elastic foundation.

The very simple theory for such beams was given by me in the publications of this association in 1950. I checked the results of Mr Bryan and Mr Mohsin with this theory and found a very good agreement.

Leere Seite
Blank page
Page vide

IIb

Incidences des tassements d'appuis sur le dimensionnement des ponts de portée moyenne

Die Wirkung von Stützensenkungen auf die Bemessung von Brücken mittlerer Spannweite

The Effect of Settling of Supports on the Dimensioning of Bridges of Medium Span

H. MATHIEU

Ingénieur en Chef des Ponts et Chaussées
Chef de la Division des Ouvrages d'Art B

Service d'Etudes Techniques des Routes et Autoroutes
92 Bagneux, France

A. DENIS

Ingénieur des T.P.E.

L'intéressante communication de Messieurs SORETZ nous conduit à présenter quelques remarques en ce qui concerne les ponts ; il nous apparaît en effet que l'exposé de MM. SORETZ porte surtout sur les bâtiments, et que les phénomènes sont, pour les ponts, un peu différents de ce qu'ils sont pour les bâtiments.

Nous avons entrepris, depuis près de deux ans, une série d'études systématiques sur les différentes manières de prendre en compte des tassements d'appuis dans le dimensionnement des ponts de moyenne importance.

Tout d'abord, pour les ponts, les problèmes rencontrés sont moins complexes que ceux qui ont été présentés pour les bâtiments, la rigidité d'un pont est essentiellement la rigidité de flexion longitudinale de son ossature porteuse, les tassements sont représentés par leurs valeurs en quelques points seulement, et la principale inconnue du problème concerne le comportement du béton armé sous l'action de charges de longue durée et progressives dans le temps.

Nous sommes d'accord que les résultats obtenus par voie théorique sont pessimistes : en effet certains exemples nous ont prouvé que la rupture effective se situe bien au delà de la limite de rupture théorique déterminée sur la base d'hypothèses élastiques. Cela prouve que la prise en compte du comportement réel des structures hyperstatiques sous l'action de charges provoquant la formation de rotules plastiques peut offrir de grands avantages. Dans nos études, qui ont porté surtout sur le béton précontraint, nous avons donc tenu compte de l'adaptation des systèmes hyperstatiques dans les limites définies par le futur règlement de calcul français du béton précontraint. En outre nous nous sommes attachés essentiellement à rechercher la meilleure manière de procéder à des renforcements locaux ou généraux, dans des proportions raisonnables.

Pour les constructions en béton précontraint l'état-limite déterminant est généralement l'état-limite d'utilisation qui, dans l'optique des futurs règlements de calcul français, constitue essentiellement un repère vis-à-vis de la durabilité des ouvrages.

Tout d'abord, comment définir « l'action » des tassements d'appuis ? Nous en avons considéré, pour commencer, un premier terme, le tassement probable, calculé à partir d'un modèle qui fait intervenir notamment les variations de pression apportées par l'ouvrage sur les couches compressibles du terrain.

Le «tassement probable» nous apporte, bien entendu, un élément d'appréciation incomplet puisqu'il ne prend pas en compte l'hétérogénéité du sol de fondation et ne tient pas compte de l'évolution du tassement au cours temps.

Nous avons donc complété la définition précédente par la notion «tassement aléatoire» d'un appui, qui est la variation possible du tassement par rapport à sa valeur probable ; cette variation peut être évaluée, dans les cas les plus courants, par les fractions suivantes : $\pm \frac{1}{6}$ pour les piles et $\pm \frac{1}{3}$ pour les remblais d'accès.

L'étude systématique de plusieurs configurations d'ouvrages nous a alors permis de définir un mode de prise en compte des effets des tassements dans le dimensionnement ou la vérification des ouvrages.

De cette étude, il ressort trois attitudes possibles selon l'importance des tassements prévisibles. Parmi les ouvrages étudiés, nous avons retenu à votre intention celui d'un ouvrage à 4 travées continues, symétrique, en dalle pleine de béton précontraint, dont la configuration d'ensemble répond au schéma suivant :

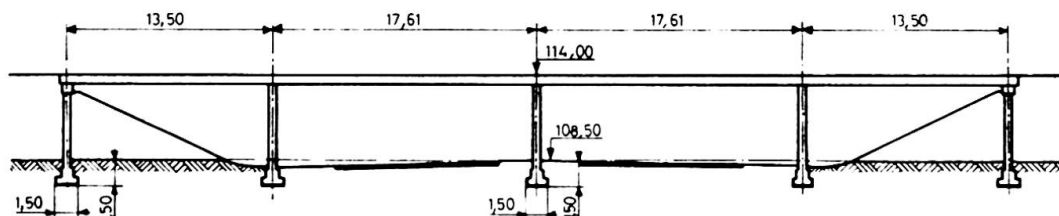

fig. 1 - Configuration de l'exemple étudié

Notre étude a considéré plusieurs épaisseurs de la dalle, permettant ainsi de définir l'épaisseur économiquement avantageuse selon l'importance des tassements. En l'absence de tassements l'ouvrage respecte les contraintes admissibles actuellement réglementaires ; en particulier la contrainte de compression du béton sur les fibres extrêmes est comprise entre 0 et 12,6 N/mm².

1) Une première attitude, suffisante en cas de faibles tassements, consiste à tenir compte des possibilités de la structure à s'adapter, voire à fonctionner selon une classe de précontrainte différente de celle prévue en l'absence de tassements. En ce cas, les tassements ne sont pas introduits dans le dimensionnement principal (épaisseur du tablier, précontrainte), et n'interviennent qu'en vérification finale pour justifier certains renforcements locaux en armatures passives. C'était l'attitude adoptée jusqu'à présent en FRANCE pour les ponts de dimension moyenne, et l'on pouvait ainsi facilement et sans trop de frais, accepter des tassements différentiels probables qui, rapportés à la portée des travées, sont voisins de $\frac{\Delta}{l} = \frac{1}{350}$ (soit environ 5 cm pour 15 mètres). Cette attitude s'affranchissait donc, dans certaines sections, des contraintes admissibles réglementaires, et le chiffre ci-dessus correspond à des contraintes supplémentaires de traction voisines de 2,5 N/mm².

La recherche actuelle d'une plus grande vérité des sollicitations effectives, l'abandon des méthodes de justification aux contraintes admissibles au profit des justifications aux états-limites, nous ont amené à faire un nouveau pas dans la prise en compte des tassements.

2) Une seconde attitude intervient alors tout naturellement ; elle consiste à introduire les tassements probables en tant qu'actions justifiant le dimensionnement principal de l'ouvrage. Pour l'ouvrage étudié, cela consiste essentiellement à accroître la précontrainte et à modifier le profil des câbles.

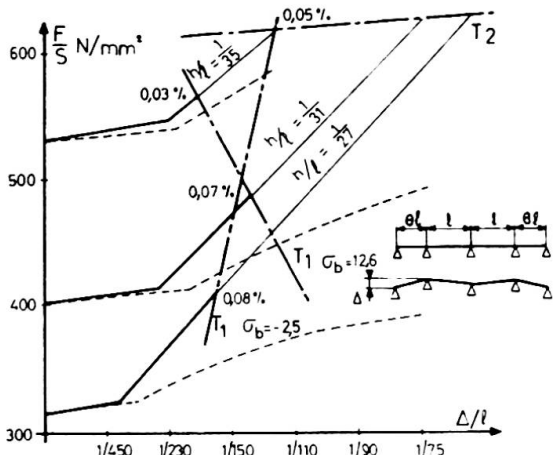

fig. 2 - Tassements probables introduits dans le dimensionnement principal. ($0 < \sigma_b < 12,6 \text{ N/mm}^2$)

Sur la figure 2, nous avons représenté la croissance de l'effort de précontrainte en fonction des seuls tassements probables introduits au dimensionnement ; en abscisse figure le tassement différentiel (différence entre celui des culées et celui des piles) rapporté à la longueur moyenne des travées ; en ordonnée nous portons la contrainte F/S due à la précontrainte au niveau du centre de gravité de la section.

Les tassements aléatoires, non pris en compte dans le dimensionnement, interviennent en vérification pour justifier certains renforcements locaux, et les chiffres qui figurent le long des courbes représentent :

1° - les contraintes extrêmes dans le béton après prise en compte des tassements aléatoires ;

2° - le pourcentage géométrique d'armatures passives (acier H.A de limite d'élasticité égale à 420 N/mm^2) à prévoir dans la section la plus sollicitée.

Dans cette vérification nous avons limité dans chaque section l'incidence des tassements aléatoires à celle des deux appuis les plus influents ; cette hypothèse, qui est en même temps une simplification, conduit à une diminution de 30 % de l'effet des tassements aléatoires ; elle est justifiée par la considération bien simple que la combinaison avec cumul de trois tassements improbables et alternés devient au total très improbable.

Les résultats obtenus nous ont montré tout d'abord que, dans cette gamme de portées sur-critiques, la croissance de l'effort de précontrainte est d'abord très faible (10 tonnes par cm de tassement) et l'incidence économique insignifiante, si l'on considère qu'une seule unité de précontrainte utilisée donne une force de 50 tonnes en phase finale. Il est donc très facile, pour les ponts-dalles en béton précontraint, de donner à la structure une résistance supplémentaire appréciable vis-à-vis des tassements.

La prise en compte des tassements est alors en fait limitée par une contrainte excessive du béton en compression lorsque l'on fait intervenir les tassements aléatoires en vérification finale. Dans notre exemple on peut accepter des tassements différentiels probables de 12 à 15 cm, au lieu de 5.

Enfin les courbes en pointillé qui apparaissent sur ce diagramme sont les résultats d'un calcul identique au précédent, dans lequel il a été tenu compte, pour un état de tassement donné, des redistributions de réactions d'appuis de charge permanente qu'il entraîne. L'incidence de ces redistributions est avant tout l'affaire de cas d'espèce ; elles interviennent de façon très favorable lorsque les tassements deviennent assez élevés, et surtout si on a affaire à une structure assez rigide. Elles dépendent également du rapport entre la part de tassement due aux appuis et remblais, et celle due au poids du tablier. Nous retrouvons ici une constatation faite par Messieurs SORETZ : si une grande part du tassement propre des piles s'est effectuée avant mise en place du tablier, les redistributions de réactions d'appuis réduiront de façon très appréciable les tassements différentiels en stade final.

3) Enfin les tassements que cette seconde attitude nous permet d'accepter peuvent s'avérer insuffisants lorsque les tassements aléatoires représentent une fraction estimée trop importante du tassement probable. Une troisième attitude consiste alors à introduire à la fois tassements probables et tassements aléatoires dans le dimensionnement principal, en limitant cette fois encore l'incidence de ces derniers aux deux appuis les plus influents.

Dans ce calcul, nous admettons l'adaptation hyperstatique de l'ouvrage dans les limites prévues par les futurs règlements de calcul français, c'est-à-dire en admettant une augmentation de la contrainte de traction égale à la moitié de la résistance caractéristique du béton en traction, tout en maintenant en l'absence de tassement le respect des contraintes admissibles.

Un diagramme analogue au précédent est alors fourni. Il laisse la possibilité de reprendre des tassements plus importants ; on pourrait, dans notre exemple, théoriquement admettre des tassements différentiels probables compris entre 15 et 20 cm. Le supplément de coût correspondant n'est pas négligeable. Nous n'avons cependant pas trouvé de cas où il atteigne celui de fondations spéciales.

fig. 3 - Tassements probables et aléatoires introduits dans le dimensionnement principal.

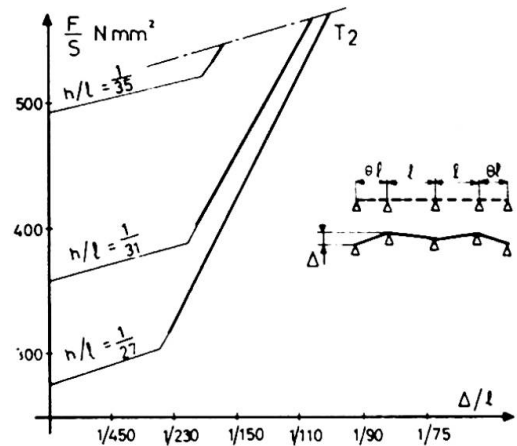

Notre conclusion principale est donc qu'il est intéressant d'accepter des tassements, en les introduisant totalement ou au moins partiellement dans le dimensionnement des ouvrages.

Enfin nous voudrions signaler que l'interaction sol-structure ne se limite pas au problème qui consiste à concilier leurs déformations respectives. Cette interaction peut être en effet exploitée avec profit par la conception de certaines structures spécialement dimensionnées pour permettre une redistribution favorable des efforts. C'est le cas en particulier pour le portique ISOSTAT inventé par le bureau SUD FRANCE et qui vous est présenté ici.

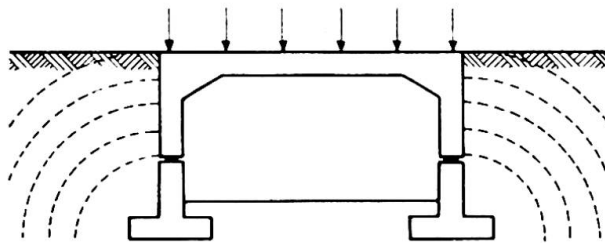

fig. 4 - Pont « Isostat »

Le pont Isostat est une structure en portique ouvert, mais se différencie des structures habituelles de ce type par la présence de joints horizontaux dans la partie inférieure des piliers. La partie supérieure de l'ouvrage, composée de la traverse et des piliers, repose par l'intermédiaire d'appuis glissants sur les parties inférieures. Ces dernières sont indépendantes du reste de l'ouvrage vis-à-vis des effets de flexion ; leur mobilité entraîne alors une redistribution des efforts dans le terrain, conduisant à la formation de demi-voûtes qui viennent s'appuyer sur la seule partie supérieure. Les parties inférieures ne sont plus sollicitées que par des charges verticales ou peu inclinées. On peut ainsi se contenter, sur mauvais

terrain, de semelles remarquablement petites.

Nous pensons, et des essais en vraie grandeur récemment effectués en France doivent logiquement nous le confirmer, que les avantages seront ceux :

- d'une relative uniformité des pressions sur le sol de fondation ;
- d'une structure isostatique présentant une grande insensibilité aux tassements.

IIb

Comments by the Author of the Introductory Report

Remarques de l'auteur du rapport introductif

Bemerkungen des Verfassers des Einführungsberichtes

LEO FINZI

Professor at the Polytechnic University

of Milan, F.A.S.C.E.

Italy

The ten Reports that have been presented concern four major items on the subject of the Interaction of different Structural Elements:

- a - Bracing systems for tall buildings
- b - Bracing effects of sheeting in factory buildings
- c - Interaction between main and secondary structural members in bridges
- d - Soil-structure interaction.

A lot of experimental research has been done on items -a- and -b- and this seems to underline the difficulty of a purely theoretical approach. Nevertheless a useful body of concrete experience for the designer has been accumulated.

Yura and Lu have shown that even in buildings using diagonal bracing the amount of total shear carried by frames can rise to 30% of the total. On the other hand under unsymmetrical vertical loads or in the final elastic-plastic phase the bracing may have to help in situations not allowed for by ordinary calculation methods.

The theoretical study by Talwar and Cohn attempts to reach a synthesis by defining those critical loads of the structural system which automatically bring about a limitation, in the maximum drift, the $P-\Delta$ effect and the "price for tallness" of the frames. To me it seems better suited to delineating rather than solving the problems, but no less interesting for that.

Wakabayashi, Kawamura, Band and Yamada have shown that the design philosophy of the bracing system in tall buildings must be quite different for, on the one hand, wind effects or the stability of the building as a whole, and on the other hand the seismic effects.

High tensile steel diagonals allow large deflections in the elastic range, leading to a better structural response and a reduced cyclic plasticity.

The report by Faltus, which stresses the importance of shear effects in interaction problems, is interesting because it shows how the same basic approach can be used for both a tall building and an arched bridge.

As a whole I feel that the Reports concerning item -a- demon-

strate that interaction between diagonal bracings and frames is a question of considerable importance presenting both favourable and unfavourable aspects that are not easy to evaluate. It might therefore seem that a clearer vision of structural behaviour would be obtained by avoiding rigid frames and relying only on diagonal bracings or on bracing walls. Besides, this makes it easier to take advantage of the flexural interaction between beams and sheeting.

The interaction between portal frames and sheeting is discussed in the Report of Bryan and Mohsin, a very exhaustive and interesting study. To have the sheeting act as a structural element is not new (see for instance the Behlen roofs) but the advantage of taking into account the sheeting as horizontal bracing appears to be very profitable, as a 25% reduction on the weight of structural steel can be achieved. An economical analysis of the cost for extra rivets would nevertheless be welcome. Vogel has worked on a problem in a more limited area of the same field: the interaction between purlins and corrugated sheets in factory roofs, and he described interesting experimental work on this subject.

Only two Reports refer to item -c-, by Sakai and Okumura and by Fukumoto and Kuto, though a lot has been written about it in the past. Moreover the above mentioned papers seem to me to verge on the limits of the field covered by Theme II b as practically they have more to do with the stiffening of a single bridge beam through appropriate secondary elements than to a real interaction between elements acting in parallel.

M. Soretz and S. Soretz, as a conclusion, gave us a survey of the problems that arise on the topic of soil-structure interaction.

In the free discussion which is about to start we will hear further contributions and ideas: D.R. Green on the influence of diaphragms in the behaviour of box girders with deformable cross section; A. Holmberg on the design of steel buildings taking account of the sheeting; J. Pechar on a unconventional bridge in Czechoslovakia; H. Mathieu on the interaction between soil and portal frames of underground passages.

Quite soon moreover a notable amount of information on structural interaction in bracing systems for tall buildings is certainly going to appear in the Monographs edited by the I.A.B.S.E.-A.S.C.E. Joint venture.