

Zeitschrift: IABSE congress report = Rapport du congrès AIPC = IVBH
Kongressbericht

Band: 9 (1972)

Rubrik: Theme VIa: Checking of actual structures

Nutzungsbedingungen

Die ETH-Bibliothek ist die Anbieterin der digitalisierten Zeitschriften auf E-Periodica. Sie besitzt keine Urheberrechte an den Zeitschriften und ist nicht verantwortlich für deren Inhalte. Die Rechte liegen in der Regel bei den Herausgebern beziehungsweise den externen Rechteinhabern. Das Veröffentlichen von Bildern in Print- und Online-Publikationen sowie auf Social Media-Kanälen oder Webseiten ist nur mit vorheriger Genehmigung der Rechteinhaber erlaubt. [Mehr erfahren](#)

Conditions d'utilisation

L'ETH Library est le fournisseur des revues numérisées. Elle ne détient aucun droit d'auteur sur les revues et n'est pas responsable de leur contenu. En règle générale, les droits sont détenus par les éditeurs ou les détenteurs de droits externes. La reproduction d'images dans des publications imprimées ou en ligne ainsi que sur des canaux de médias sociaux ou des sites web n'est autorisée qu'avec l'accord préalable des détenteurs des droits. [En savoir plus](#)

Terms of use

The ETH Library is the provider of the digitised journals. It does not own any copyrights to the journals and is not responsible for their content. The rights usually lie with the publishers or the external rights holders. Publishing images in print and online publications, as well as on social media channels or websites, is only permitted with the prior consent of the rights holders. [Find out more](#)

Download PDF: 04.04.2026

ETH-Bibliothek Zürich, E-Periodica, <https://www.e-periodica.ch>

VI

**Etudes expérimentales du comportement
des ouvrages sous les sollicitations**

**Experimentelle Studien über das Verhalten
der Bauwerke unter Belastung**

**Experimental Study of the Behaviour
of Structures under Loads**

VI a

Contrôle des ouvrages existants

Kontrolle bestehender Bauten

Checking of Actual Structures

Leere Seite
Blank page
Page vide

Vla

Kontrollmessungen an Brückenkonstruktionen

Control Measurements of Bridges

Mesures de contrôles de ponts

A. SZITTNER

TU Budapest, Lehrstuhl für Stahlkonstruktionen
Budapest, Ungarn

Die Mitarbeiter des Lehrstuhles für Stahlkonstruktionen der TU Budapest haben in den letzteren Zeiten an den in Ungarn gebauten verschiedenen Brückenkonstruktionen Kontrollmessungen durchgeführt, um die wirkliche und theoretische Kräftespiele gegenüberzustellen. Die Messungen wurden in fünf Gruppen klassiert:

1. Traditionelle Probelastung,
2. Lastenzug-Einflusslinie,
3. Dynamisches Verhalten der Brücken,
4. Feststellung des Brückenzustandes,
5. Kontrollmessungen während des Baues.

Die Mess- und Auswertungsmethode bzw. die Folgerungen werden auf Grund der Messungen an den untenstehenden Strassenbrückenkonstruktionen vorgestellt:

- a/ Hängebrücke mit Spannweite 44 + 290 + 44
- b/ Verbundkonstruktion mit Kastenträger (Spannweite: 30 m)
- c/ Durchlaufende Fachwerkbrücke mit Eisenbeton-Fahrplatte als Verbundkonstruktion mit Querträger (Spannweite: 3x70 m)
- d/ Durchlaufende Verbundkonstruktion mit Kastenträger (Spannweite: 3x25 + 40 + 2x25 m)
- e/ Durchlaufende Vollwand-Verbundkonstruktion mit Freikabel-Vorspannung (Spannweite: 57 + 67 + 57 m).

1. Traditionelle Probelastung

Der Inbetriebnahme der Brücken geht immer ein amtlicher Prozess, die Probelastung voran, wo den Vorschriften nach, nur die Durchbiegungen gemessen werden sollen. So wird das Kräftespiel und das Verhalten der Konstruktion im Ganzen kontrolliert. Im wissenschaftlichen und praktischen Sinne ist es aber auch wichtig, die wirklichen Spannungen und Beanspruchungen der Brückenelemente mit den theoretischen Werten, gewonnen an den mathematischen Modellen, zu vergleichen.

Durch die Messungen werden

die örtlichen Spannungen und Spannungsspitzen,
die Knotenpunkt-Nebenspannungen,
die Querverteilung und Torsionssteifigkeit, und
die Fahrbahn-Mitwirkung

kontrolliert.

Als Mess-System wurden bei den obenerwähnten Aufgaben Dehnungsmess-Streifen (DMS) mit Messverstärker und mit Registrierungseinrichtung, oder Dehnungsmesser mechanischen Systems angewendet.

Über die Messungen der örtlichen Spannungen kann nichts Neues gesagt werden. Um die Knotenpunkt-Nebenspannungen festzustellen, wurden die Spannungen (Dehnungen) neben den ausgewählten Knotenpunkten auf jedem Stab bei der Stabmitte und neben dem Knotenblech in den 4 Eckpunkten der Querschnitten gemessen. Auf Grund des Bernoulli-Navier-Satzes werden aus den Messergebnissen die Werte σ_N , σ_{Mx} , σ_{My} und σ_W gerechnet. Auf der Brückenkonstruktion nach Abb.4. in den Knotenpunkten 25 und 28 wurden die Nebenspannungen festgestellt. Bei den Gurtstäben sind die gemessenen Werte ein wenig höher als die gerechneten Werte nach Hartmann-Melan [1], aber bei den Diagonalen, wo die Stabkräfte bzw. die σ_N -Spannungen im absoluten Sinne kleiner sind, sind die Nebenspannungen prozentuell viel höher. Auf Abb.1. wurde die Tendenz vorgestellt, dass die Knotenpunkt-Nebenspannungen mit der Zunahme der Ausnutzung des Stabes sich vermindern. Die Nebenspannungen waren immer beachtlich [2].



Abb.1.

Auf dieser Brücke wurde auch die Querverteilung kontrolliert. Die Messergebnisse und die Werte - gerechnet nach Cornelius [3] - zeigten weder bei symmetrischer, noch bei asymmetrischer Belastung gute Übereinstimmung. Die Messergebnisse unterstützten viel mehr eine Rechenmethode wobei die Konstruktion als einfacher Träger auf zwei Stützen gerechnet wurde (Abb.2.).

An der selben Konstruktion wurde auch die Mitwirkung der Fahrbahnkonstruktion überprüft. Die Spannungen in dem Untergurt sind wegen der Mitwirkung der Fahrbahnplatte etwa 20-30 % kleiner, als die ohne Mitwirkung gerechneten Werte. Dementsprechend sind aber

die Obergurt-Kräfte durch die Verkürzung des Hebelarmes der Zugdruckkraft etwa 10-15 % höher, als die Werte einfach berechnet.

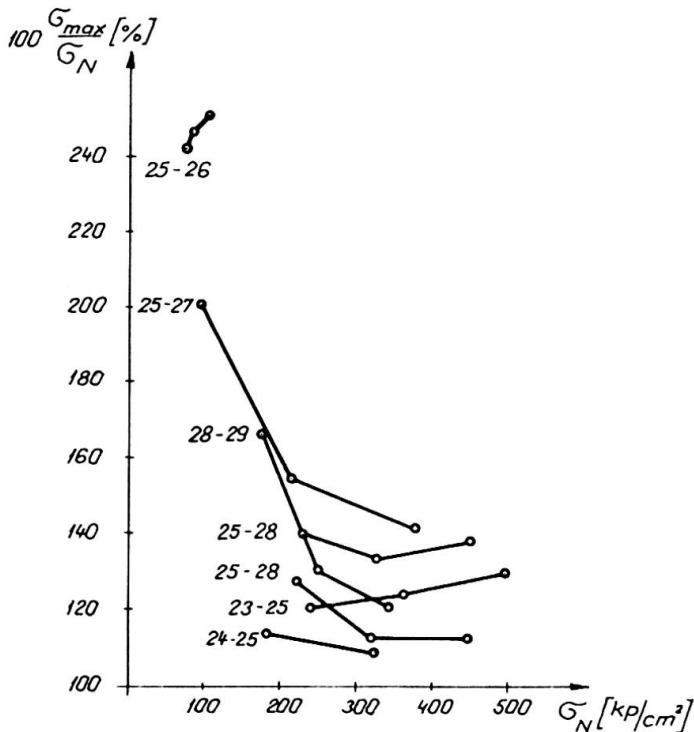
Diese Differenz vermindert sich bedeutend neben den Stützen, wo die Fahrbahnplatte untergebrochen ist.

2. Lastenzug-Einflusslinien

Im Laufe der traditionellen Probelastung werden die bei einer genau bestimmten Achsenanordnung gemessenen und berechneten

Deformationen und Spannungen verglichen. Man bekommt aber ein besseres Bild über das Verhalten der Konstruktion, oder Konstruktionselemente, wenn die Belastung mit der Hilfe eines in der Fahrbahnachse sich langsam bewegenden Schwerlastwagens wirkt, und die Spannungen und Deformationen mit einer Registrier-einrichtung aufgenommen werden. Die auf Grund der Einflusslinien gerechneten Werte werden den wirklichen Registrieraturnwerten gegenübergestellt.



Abb. 2.

Die auf den verschiedenen Punkten des Kastenträgergurtes gemessenen Spannungen zeigen gut die Spannungsverteilung der Brücke. Der Durchschnittswert der Messergebnisse stimmt sehr gut mit dem gerechneten Wert [4].

Abb. 3. zeigt die Gegenüberstellung der Lastenzug-Einflusslinie bei einer Verbund-Konstruktion mit Kastenträger ($l = 30$ m). Die auf den verschiedenen

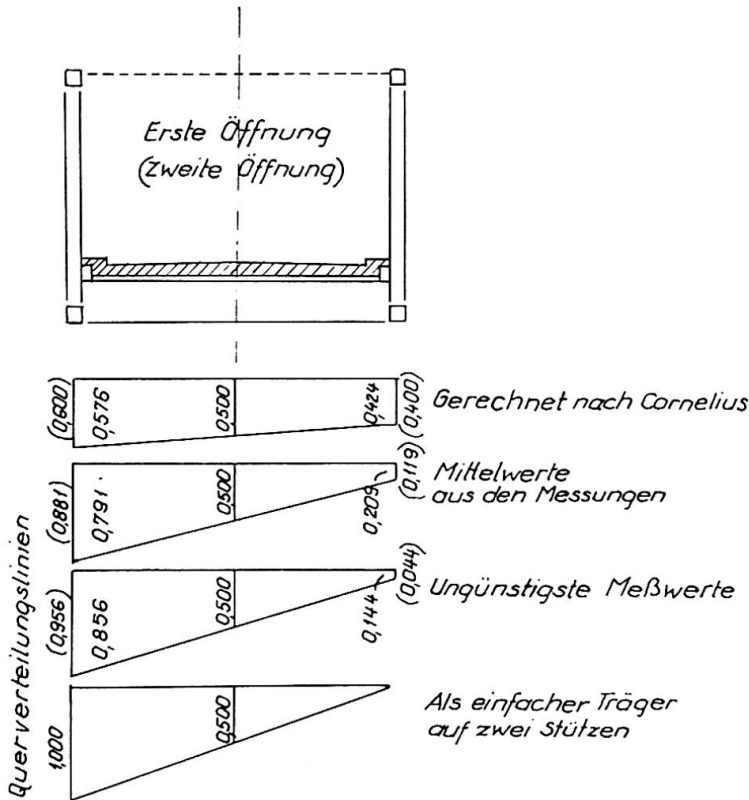

Abb. 3.



Abb. 4.

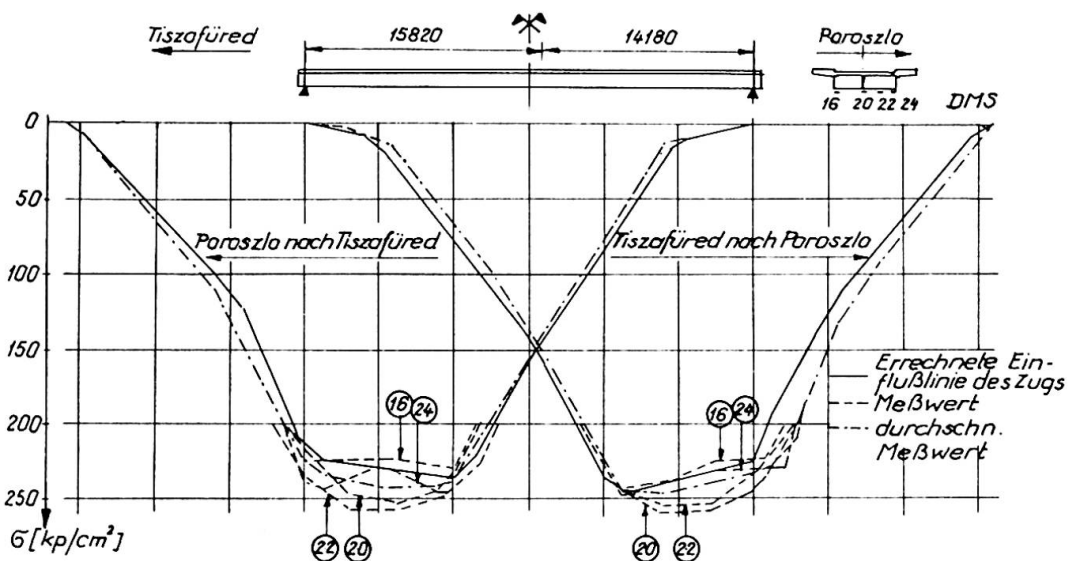

Abb. 5.

Auf Abb.4. sind die Lastenzug-Einflusslinien für die Stabspannungen eines durchlaufenden Fachwerkträgers zu sehen. Der Ursprung der Abweichung zwischen den gerechneten und gemessenen Spannungen ist auch jetzt die Mitwirkung der Fahrbahnplatte. Deswegen ist die Obergurtkraft etwa 20 % höher, die Untergurtkraft etwa 10 % niedriger, als die ohne Mitwirkung der Fahrbahnplatte gerechneten Werte. Bei dem Obergurt 23-25 gab es in der Seitenöffnung infolge der Fahrbahnplatten-Unterbrechung keine bedeutende Differenz, aber in der Mittelöffnung war die Differenz schon beachtlich.

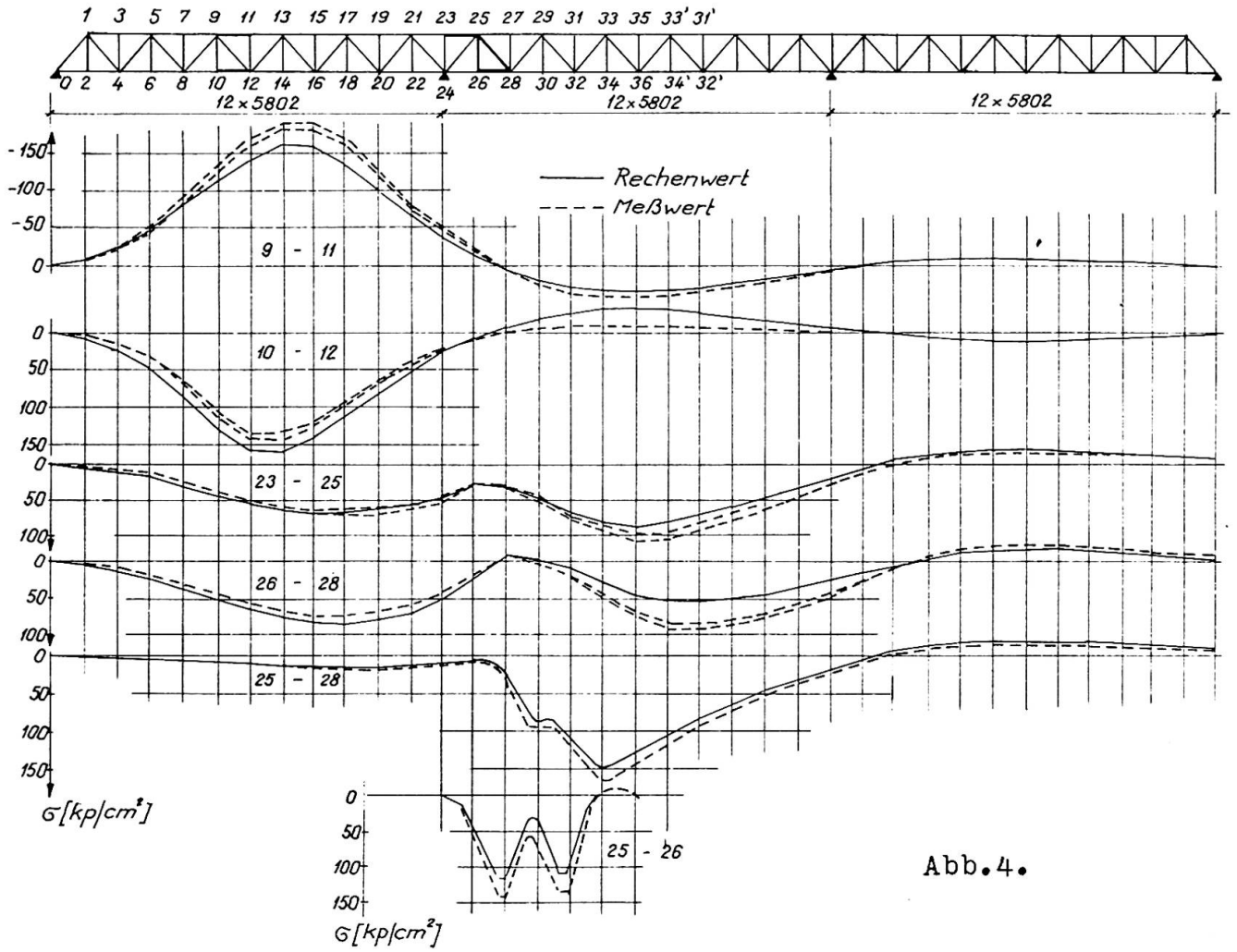
In dem Gurtstab 26-28, wo die Stabkräfte etwas kleiner sind, ist die Abweichung ein bisschen grösser. Die Differenz meldet sich besonders in dem Charakter der Einflusslinie. Bei den Diagonalen 25-28 und 25-26 ist die Abweichung nicht bedeutend.

Die Lastenzug-Einflusslinien geben ein sehr gutes Bild über die Querverteilung der kastenartig ausgebildeten Brückenquerschnitten. Als Beispiel werden die Messergebnisse einer mit äusseren Kabeln gespannten, schrägen, durchlaufenden Verbundkonstruktion erwähnt (Abb.5.). Wegen des schrägen Grundrisses und der asymmetrischen Fahrbahn-Anordnung sind die Spannungen in den drei Hauptträgern verschieden, andererseits wegen der besseren Betonqualität etwas kleiner, als die nach dem Entwurf gerechneten Werte.

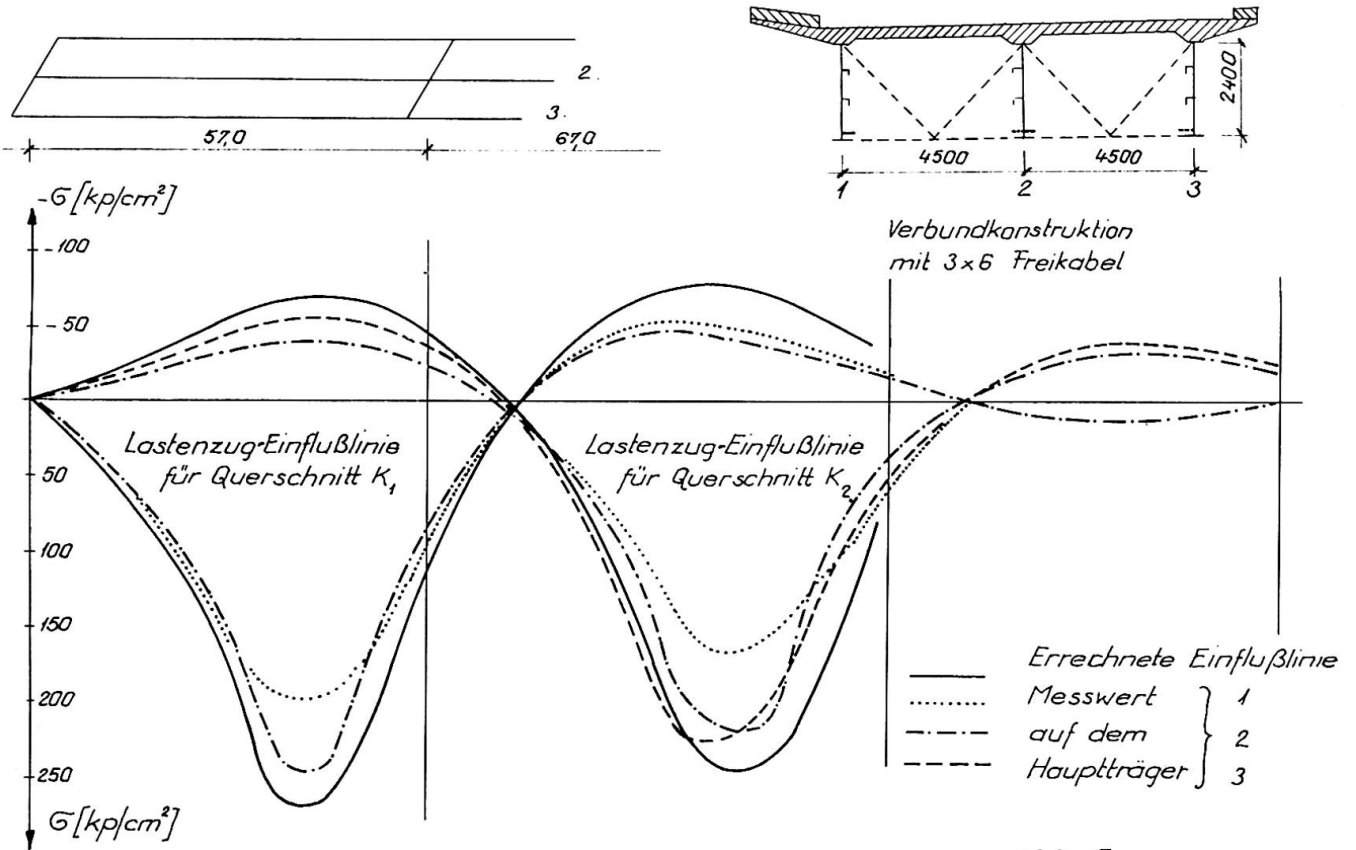
3. Dynamisches Verhalten der Brücken

Die meisten Bemessungsvorschriften berücksichtigen die aus der Bewegung stammende dynamische Zusatzlast mit einem sogenannten dynamischen Faktor, der von der Art der Brücken abhängt und mit der Spannweite sich vermindert. Bei einer konkreten Konstruktion ist die Zusatzlast proportional mit der Nutzlast. Diese Voraussetzung wurde durch die experimentellen Werte nicht unterstützt. Deshalb bestrebte man theoretisch oder experimentell einen Zusammenhang, der das dynamische Verhalten der Brücken treu spiegelt. Die Grunderscheinungen und die Grundgleichungen der Lösung sind theoretisch klar (Effekt von Timoshenko, Zimmermann, usw.), aber eine allgültige Superpositionsregel oder ein Zusammenhang der dynamischen Wirkung ist wegen der zeitlichen und räumlichen Zufälligkeit der Lasten unmöglich zu finden.

Aus diesem Grunde hat der UIC-ORE (Internationaler Eisenbahnverband, Forschungs- und Versuchsamt) für Eisenbahnbrücken eine umfangreiche Experiment-Serie angefangen und die Messergebnisse ausgewertet. In der zusammenfassenden Veröffentlichung [5] hat der ORE die eindeutige Folgerung festgestellt, dass es unmöglich ist, die wirkliche dynamische Wirkung in geschlossener Form sogar bei zwangsbahnartiger Eisenbahn-Belastung festzustellen. Die Anwendung des dynamischen Faktors als Bemessungsmethode spiegelt das wirkliche Kräftespiel nicht.



Abb.6.

Gleichzeitig mit den anderen Probelastungen wurde in dem Geist der Arbeit von UIC-ORE auch dynamische Probelastung durchgeführt, wo die Lastkraftwagen auf der Brücke in verschiedenen Gruppen und mit verschiedener Geschwindigkeit gefahren wurden.

Die Auswertung der Registraten wurde nach der Abb.6 gemacht. So wurden die charakteristischen Werte von σ_{stat} , σ_{din} , $\mu = \sigma_{din} / \sigma_{stat}$ und $\Delta\sigma = \sigma_{din} - \sigma_{stat}$ für jede Fahrt festgestellt. Mit verschiedenen Lastgruppen wurde erreicht, dass die Ausnützung der Träger verschieden sei. Als Ausnützung wurde ein prozentuelles Verhältnis zwischen dem Messwert σ_{stat} und dem Rechenwert $\sigma_{stat,max}$ genommen.

So wurden die Ergebnisse als Funktion der Ausnützung erstens auf Grund des dynamischen Faktors μ , zweitens auf Grund des dynamischen Mehrwertes $\Delta\sigma$ aufgezeichnet. Wenn die Hüllkurve dazu eingezeichnet wird, ist der Charakter des dynamischen Faktors, bzw. des dynamischen Mehrwertes sehr schön zu sehen.

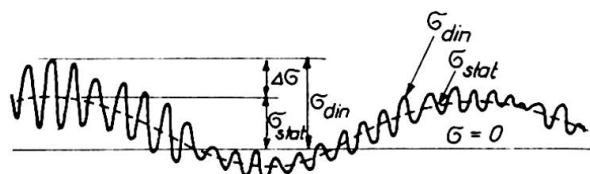

Abb.7.



Abb.8.

Als Beispiel wird auf den Abbildungen 7. und 8. die Auswertung der Messergebnisse der Brücke von Tiszafüred (Fachwerkträger und Vollwandträger siehe auf Abb.3,4); auf der Abb.9. die Auswertung der Messergebnisse der Elisabeth-Brücke, und auf Abb.10. die Auswertung der Messergebnisse einer durchlaufenden Verbundkonstruktion vorgestellt.

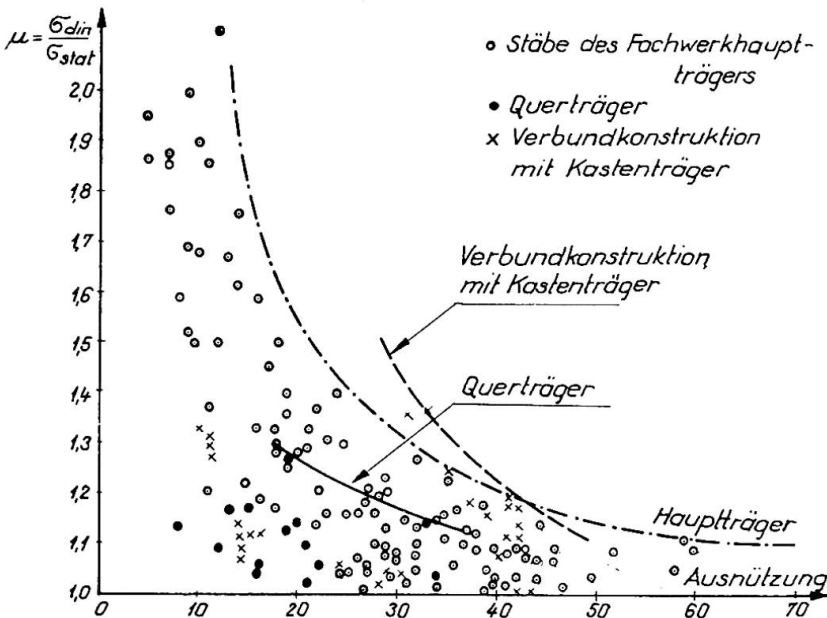

Abb.9.

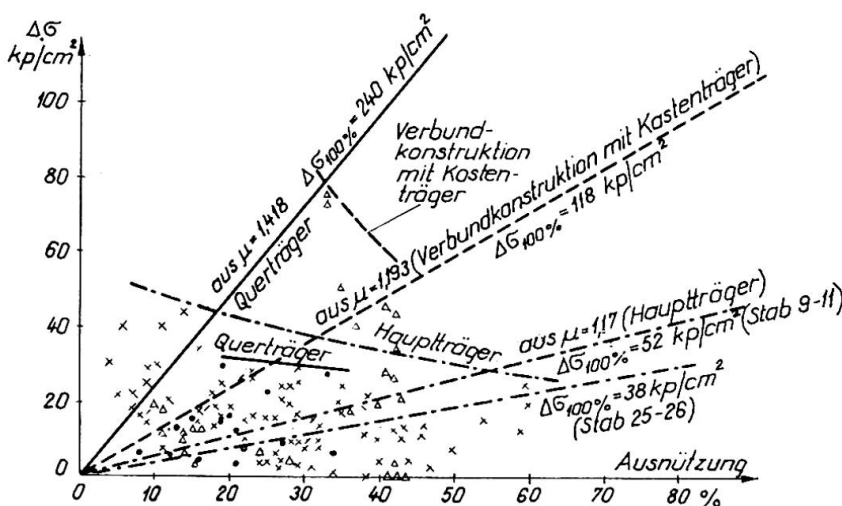

Abb.10.

Auf Grund der Messergebnisse wurden die nachstehenden Folgerungen festgestellt:

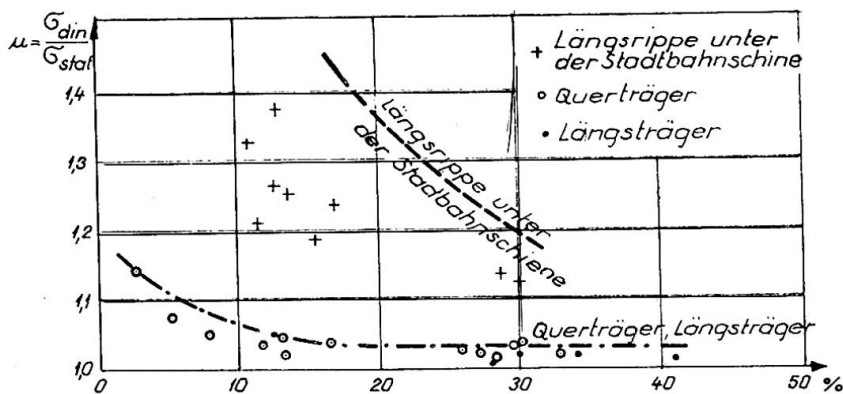
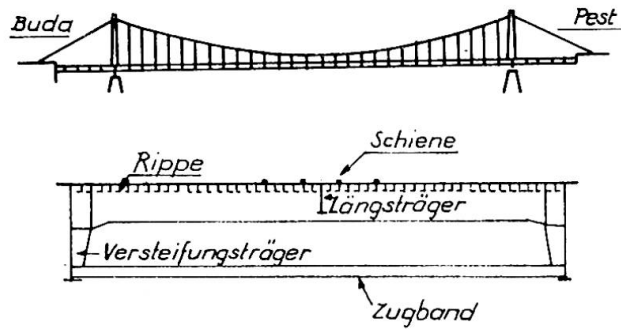

Abb.11.

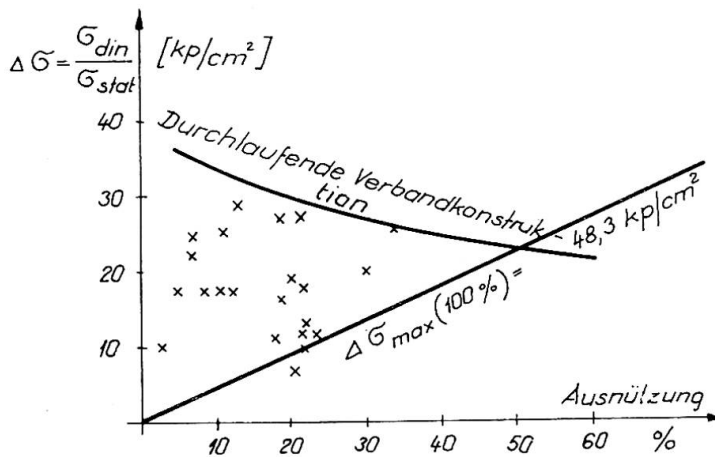
UIC-ORE vorgeschlagen wurde, statt des dynamischen Faktors den dynamischen Mehrwert anzuwenden (Abb.11.).

4. Feststellung des Brückenzustandes

Bei den neueren Brückenkonstruktionen, besonders bei den Stahlbeton- und Verbundkonstruktionen, wurden auf Grund des Vorschlages von I. Illésy die Eigenfrequenzen der Konstruktion auch gemessen. Es ist nämlich selbstverständlich, dass die nicht gut sichtbaren mechanischen Aenderungen (Risse, Stützenbewegungen usw.) auch die gut messbare Eigenfrequenz verändern können. Die Eigenfrequenzmessungen sind auf den neueren Brücken durchgeführt und ständig kontrolliert worden. Über die Erfahrungen kann noch nicht berichtet werden.

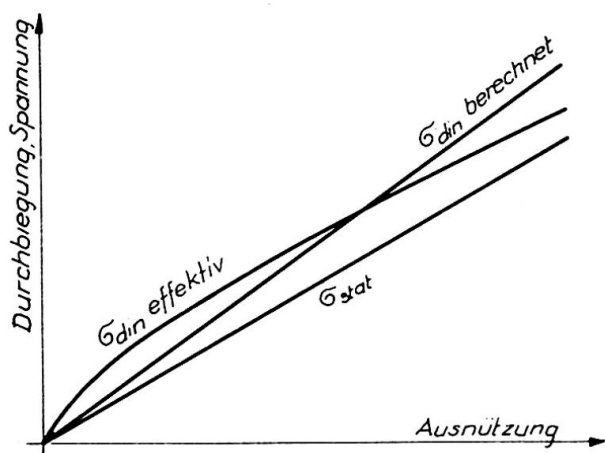
5. Kontrollmessungen während des Baues

Im Laufe der Bauzeit ist es sehr wichtig, besonders bei den durchlaufenden Verbundkonstruktionen und bei den vorgespannten Konstruktionen das wirkliche Montage-Kräftepiel und die Wirkung der verschiedenen Montagephasen (Stützensenkung, Belastung, Vorspannung usw.) zu beobachten. Diese Aufgabe benötigt eine Messmethode, wo die Messprozesse während der verhältnismässig langweiligen Bauzeit weitergeführt und die Messelemente aufbewahrt werden können. Ausserdem soll die Wirkung der Temperaturänderung beseitigt werden. Bei solchen Aufgaben wurde als Messinstrument der Setzdehnungsmesser Bauart Pfender sehr gut angewendet, der mit einer Messlänge von 100 mm, mit entsprechender Temperaturkompensation, eine Genauigkeit von 20 kp/cm² sichert. Mit dieser Methode wurde in Ungarn der Bau von zwei durchlaufenden Verbundkonstruktionen in der Bauzeit durch mehrere Monate ständig kontrolliert.

a/ Der Wert von $\tilde{\sigma}_{din}/\tilde{\sigma}_{stat}$ ist kein Konstant, es vermindert sich mit dem Wachsen der Ausnützung.

b/ Der dynamische Mehrwert ($\tilde{\sigma}_{din} - \tilde{\sigma}_{stat}$) vermindert sich in Tendenz, oder stagniert.

c/ Die dynamische Vollbelastung der Strassenbrücken ist unmöglich. Unseren Erfahrungen nach ist die maximale Ausnützung etwa 60-70 %.

d/ Bei der Dimensionierung der Strassenbrücken wäre auch richtiger, so wie es von

Literatur

- [1] Hartmann-Melan: Der Brückenbau. Franz Deuticke Verlag, Wien, 1951.
- [2] Tóth-Visontai: Statische Messungen an der Strassenbrücke über die Theiss bei Tiszafüred. Periodica Polytechnica Vol. 13. No 3-4. Budapest 1969.
- [3] Cornelius: Über den Einfluss der Torsionssteifigkeit auf die verdrehung von Tragwerken. MAN-Forschungsheft, Augsburg, 1951.
- [4] Kristóf-Szittner: Dynamische Untersuchungen an der Tisza-Strassenbrücke bei Tiszafüred. Periodica Polytechnica Vol. 13. No 3-4. Budapest 1969.
- [5] Frage D 23. Ermittlung der dynamischen Beanspruchungen von Brücken. Bericht über den Vorversuch an der Rhonebrücke Riddes der SBB. UIC-ORE, Utrecht, 1957.

Zusammenfassung

Der Lehrstuhl für Stahlkonstruktionen der TU Budapest hat an verschiedenen neugebauten Stahlbrücken Kontrollmessungen durchgeführt. Mittels dieser Messungen wurden die auf theoretischem Grunde gerechneten Werte des Kräftespieles, der Querverteilung, der Torsionssteifigkeit, der Knotenpunkt-Nebenspannungen, das dynamische Verhalten der Strassenbrücken und das Kräftespiel in verschiedenen Bauphasen kontrolliert. Der Diskussionsbeitrag gibt einen Überblick über die Messmethoden und die Ergebnisse.

Leere Seite
Blank page
Page vide

Via

Actual Traffic Loadings on Highway Bridges and Stress Levels in Bridge Members

Charges de trafic actuel sur ponts-routes et niveaux de sollicitations
dans les membrures des ponts

Gegenwärtige Verkehrslasten auf Strassenbrücken und Beanspruchungs-
Niveau in Brückenelementen

EIICHI MURAKAMI
Director
Honshu-Shikoku Bridge Authority

TETSUO KUNIHIRO
Chief, Bridge Section
Public Works Research Institute
Ministry of Construction

MINORU OHTA
Deputy Chief, Second Design Room
Honshu-Shikoku Bridge Authority

HAJIME ASAKURA
Research Engineer, Bridge Section
Public Works Research Institute
Ministry of Construction

Japan

1. Introduction

The design live load specified in the design specifications for highway bridges in Japan, as shown in Fig. 1 and Fig. 2, is fundamentally based on a 20 ton truck and traffic rows composed of a 20 ton truck and 15 ton trucks. The T-load in Fig. 1 is used for design of slab and floor system, while the L-load shown in Fig. 2 is used for design of main girder and main truss. These loads have been used since 1956, but the increase in both weight and number of trucks in these years is so remarkable that the loads shown in the current specifications have reached the state which may not be necessarily appropriate in contrast with the actual traffic situation. Besides, there exist a great number of old bridges which were designed for smaller load, than that of current specifications, and the safety of those bridges under the present heavy load is posing a problem.

In Japan, various surveys of actual traffic loadings and stress levels in highway bridge members are being carried out for the purpose of obtaining the data in re-examination of design live load, and also for control of safety of existing bridges.

2. Stress levels in bridge members¹⁾

Stress levels caused in the main girder of 18 plate girder bridges (with span length of 20 to 60 m) and for each member of a truss bridge (with span length of 80 m) under the ordinary traffic loading were measured.

In measuring, the device enabling to automatically count up the frequency by each stress level separately was used. This device is composed of the strain detector in which differential transformer is used and recording device which classifies the detected strain separately by four class levels, and count up the respective frequency.

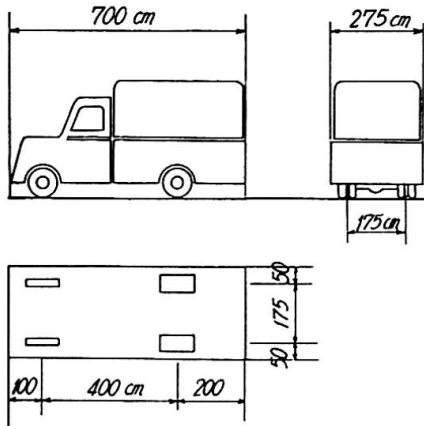

Total weight 20 ton
 Weight of front wheel 2 ton
 Weight of rear wheel 8 ton

Fig. 1 T - load

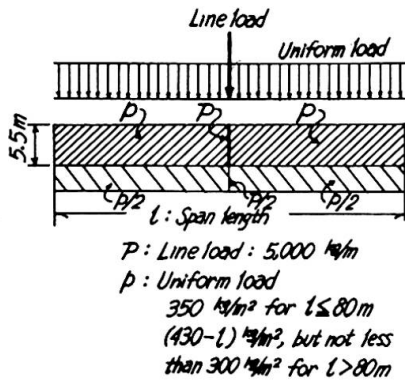

Fig. 2 L - load

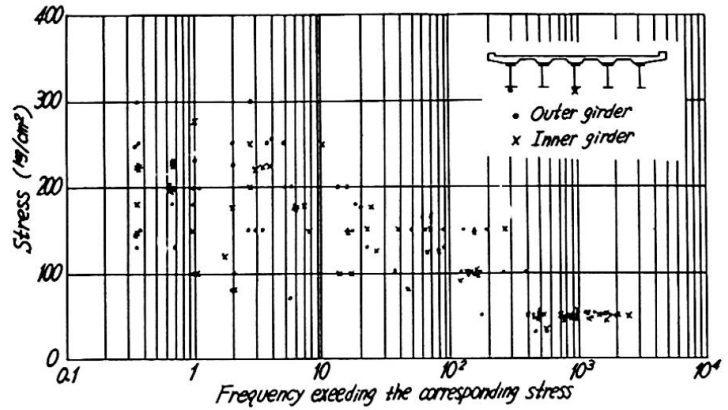

Fig. 3 Stress frequency (Plate girder bridge)

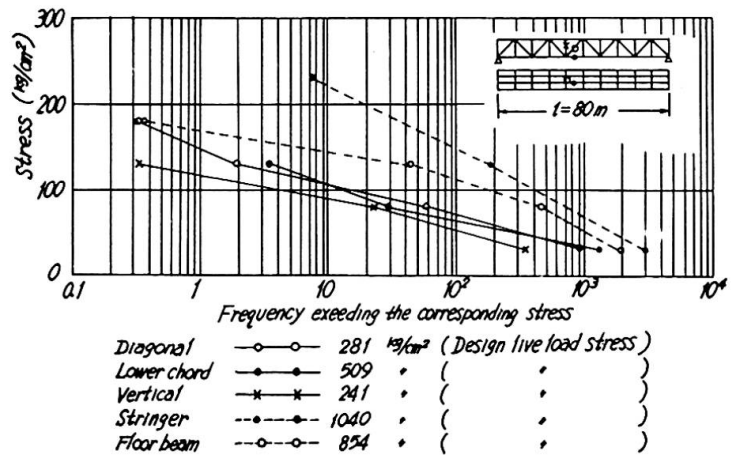

Fig. 4 Stress frequency (Truss bridge)

Type of Vehicles	Passenger Car	Bus	Small Size Truck (Gross Weight of 7.5 ton or less)	Large Size Truck (Gross Weight of 7.6 ton or more)	Total
Ratio (%)	67.9	18.1	1.5	12.5	100

Table 1. Percentage of various vehicles

The bridges for which the survey was made were selected from those which are located on the main national highways served for heavy traffic. The traffic amount per 24 hours at the survey point counts 10,000 to 40,000 vehicles, and the average traffic volume for the entire survey points was about 20,000 vehicles, the percentage of various types of vehicles being as shown in Table 1.

The measurement was carried out for 3 to 5 consecutive days. The result of measurements for plate girder bridges and a truss bridge are indicated in Fig. 3 and Fig. 4, respectively. In those

figures, the frequency at each stress level is shown per one day (24 hours). The relation between the range of the ratio of stress level measured in girder bridges to the calculated stress due to the current design live load (L-load) and the frequency caused per the traffic volume of 10,000 vehicles is shown in Fig. 5.

In the case of truss bridge shown in Fig. 4, the values of measured stress of floor system is greater than those of truss members. However, the ratio of measured stress level to design live load stress for floor system is smaller than that of truss members. This is supposed to be due to the fact the reinforced concrete slab supported by the stringers and floor beams may take charge a portion of the function of stringers or floor beams. Such a function of reinforced concrete slab was not considered in the design calculation.

According to the fact mentioned above, it is known that the live load stress caused in each member of bridge under ordinary traffic load is some 300 kg/cm² at most, which is fairly at lower level as compared with the calculated stress level due to design live load.

3. Actual status of wheel load²⁾³⁾

For the purpose of confirming the actual weight of wheel load of vehicle having great influence on the slab and floor system, measurement of weight of wheel load was carried out at 34 points on national highways in Japan.

The device used for the measurement is composed of weighing part and recording part. The weighing apparatus is the weighing meter consisting of a sheet of steel plate and four loadcells

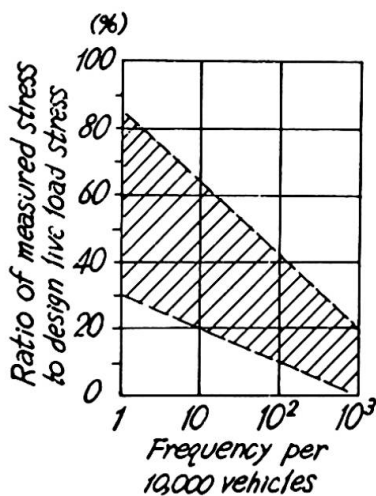

Fig. 5 Ratio of measured stress to design live load stress

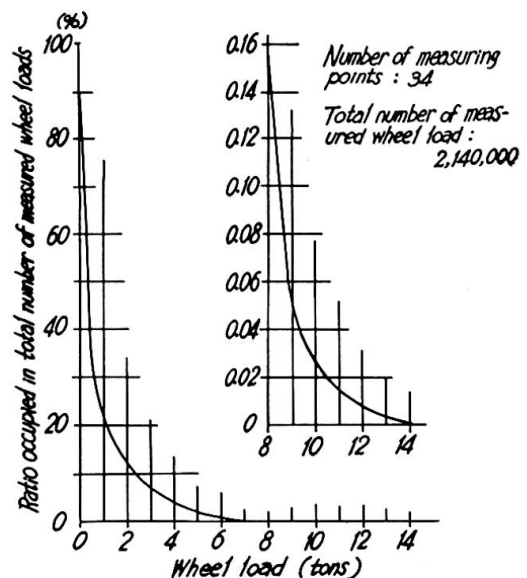

Fig. 6 Cumulative frequency distribution of wheel load

supporting the plate on its four corners. The weighing meter is installed in the reinforced concrete pit in such a way that the loading plate makes a part of the road surface covering the pit, so that the weight of wheel passing over the plate is detected without stopping the vehicles. The recording part has the function of classifying counting automatically each frequency of the detected weight by every 12 classes of level.

The survey points were selected from among the points located on main national highway, and besides, where the traffic is especially crowded. The traffic volume per 24 hours for the lane where the wheel load was measured indicated about 5,000 vehicles at point where the traffic volume was the least, and about 28,000 vehicles where the traffic volume was the most.

The measurement was carried out for 1 to 7 days for each point. It was made clear, as the result of the survey, that the frequency by different level of wheel load showed considerable difference according to the survey point, but on the same point, approximately the same frequency distribution was observed.

Fig. 6 represents the frequency measured by various weight of wheel load. As known from Fig. 6, although about 80% of the whole number of wheel load measured is one ton or less, and the number of heavier wheel load decreases rapidly, the fact that the number of wheel load exceeding design wheel load of 8 ton (which is approximately the same as the wheel load of HS20 of AASHO, see Fig. 1) amounts to 0.16% of whole number of wheel load, namely, that there exist about 32 vehicles of which wheel load exceeds design wheel load of 8 ton, per 10,000 vehicles, may not be ignored from the point of view of design of new bridges or maintenance and safety of the existing bridges. The reason of the existence of wheel loads heavier than design wheel load is due, needless to say, to the operation of large size trucks which are loaded more than the statutory loading limit.

In Japan, the expansion of truck size has been advanced in these years to reduce the cost of transportation. At the same time, the instances of damages of reinforced concrete slab have become remarkable. As one of the causes thereof, the operation of vehicles with weight heavier than design wheel load may be mentioned.

Besides, on account of the fact that the weight and number of wheel loads of trucks increased, the importance of performing fatigue design came to be claimed on steel plate deck where welding is used abundantly. In applying fatigue design, it is necessary to know the value and number of repetition of stress imposed during the expected life of bridge. From the point of view of fatigue, the effect of random wheel loads with different weights and numbers of repetition on steel plate deck may be evaluated by means of "equivalent number of repetition" of design live load stress due to design wheel load (8 ton), denoted by the following expression:

$$N_{eq} = K_1 \cdot K_2 \cdot N_t \quad (1)$$

Where N_{eq} : Equivalent number of repetition of design live load stress

N_t : Number of total passing wheel loads during the expected life of the bridge

K_1, K_2 : Coefficients

K_1 in Equation (1) is the coefficient used for converting the wheel load with certain weight into design wheel load of 8 ton, which may be expressed as Equation (2):

$$K_1 = \sum P(T) \left(\frac{T}{8} \right)^{\frac{1}{k}} \Delta T \tag{2}$$

Where T : Weight of wheel load

$P(T)$: Probability of occurrence of T

k : Coefficient determined from S-N diagram (the slope of S-N diagram in logarithmic scale.)

The position where wheel loads pass in certain traffic lane is not stationary. Fig. 7, illustrated as an example, shows that the distribution of passing positions of wheel loads in a traffic lane may be regarded as a normal distribution with the standard deviation of approximately 35 cm. Fig. 7 was obtained as the result of observation at 20 different points on national highways with two or four lanes, all over Japan. K_2 in Equation (1) is the coefficient to be multiplied with the number of repetition determined on the assumption that the all wheel loads pass on a fixed position, and is given from the following equation:

$$K_2 = \sum \left(\frac{R(x)}{R_0} \right)^{\frac{1}{k}} P(x) \Delta(x) \tag{3}$$

Where R_0 : Design live load stress

$R(x)$: Stress of member under the design wheel load passing on certain position, x

$P(x)$: Probability of occurrence of $R(x)$

The value of K_2 for the longitudinal rib of steel plate deck which is commonly used in Japan, is approximately 0.2.

$P(T)$ in Equation (2) is given by Fig. 6, and $P(x)$ in Equation (3), by Fig. 7. Such data, actually observed concerning the weight and the passing position of wheel load are indispensable for the fatigue design.

4. Actual status of vehicle row load^{2), 3)}

L-load, shown in Fig. 2, depends upon the vehicle row load such as shown in Fig. 8.

In order to ascertain the magnitude of actual vehicle row

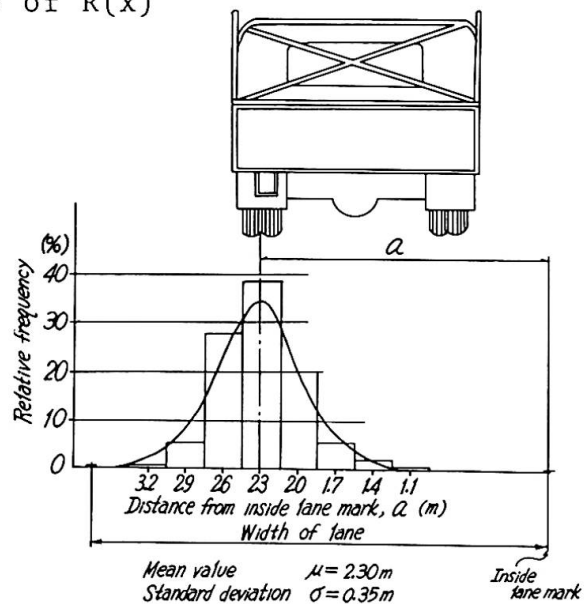

Fig. 7 Distribution of passing position of wheel

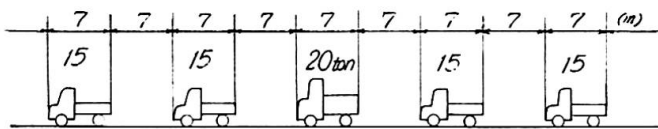

Fig. 8 Basic traffic pattern of L-load

Number of lanes	Number of points
2	25
4	40
6	8
	73

Table 2. Number of traffic pattern survey points

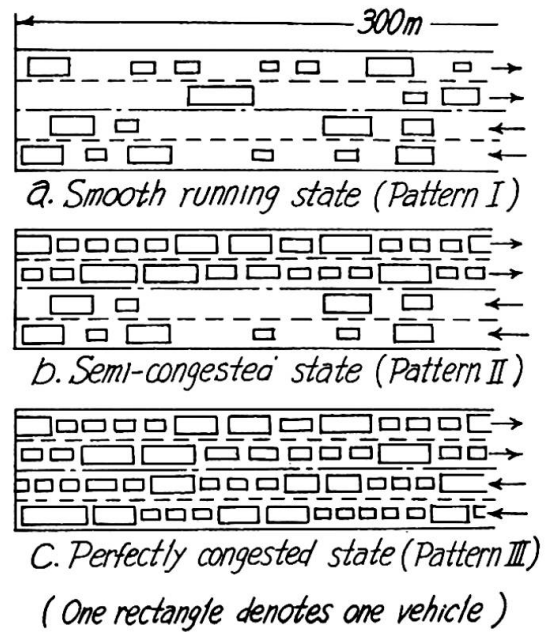

Fig. 9 Traffic patterns

load in comparison with the above design L-load, a survey on traffic pattern was carried out in the following procedure:

- 1) 73 survey points were selected (Table 2). These points are the places on the main national highways where the traffic is crowded and apt to be congested including a lot of large size vehicles.
- 2) At each survey point, traffic pattern extending over 300 m on the roadway was photographed intending to take as many heavy trucks as possible in the overlooked picture. Ten times of the photographing was carried out, and selected one case of pictures which appeared to be most congested in traffic, as they were assumed to represent the maximum of vehicle row load at the point.
- 3) Distinguishing the loading condition of each vehicle with or without cargo, as well as the type of each vehicle from the photograph, the figure of traffic pattern (Pattern I), as illustrated in Fig. 9a, which shows exactly same arrangement of vehicles as on the photograph was prepared. For the weight of different types of vehicles and different loading conditions, corresponding average values were established referring to the table of size and weight of motor vehicles in Japan.
- 4) On the basis of Pattern I, hypothetic pattern such as Fig. 9b (Pattern II) in which the half of traffic lanes is congested, while the opposite half lanes is smooth, and Fig. 9c (Pattern III) in which the whole lanes are perfectly congested, were prepared. In this case, the clear distance between two consecutive vehicles in the congested state was taken as 1 m, with reference to the vehicle distance observed on highways actually at the time of congested. Pattern II is the state which is usually observed in Japan, and Pattern III is the state which is very rarely observed.

5) In regard to Pattern I, II and III, the maximum bending moment M_0 and maximum shear force S_0 , which are imposed in a simply supported girder under each loading pattern, were calculated by means of electronic computer. In this case, M_0 and S_0 were obtained for nine cases of the span length of 20, 40, 60, 80, 100, 150, 200, 250 and 300 meters.

6) M/M_D and S_0/S_D were calculated, which are the ratio of M_0 and S_0 due to "actual vehicle load" obtained in 5), to bending moment M_D and shear force S_D due to "design load" showed in Fig. 2.

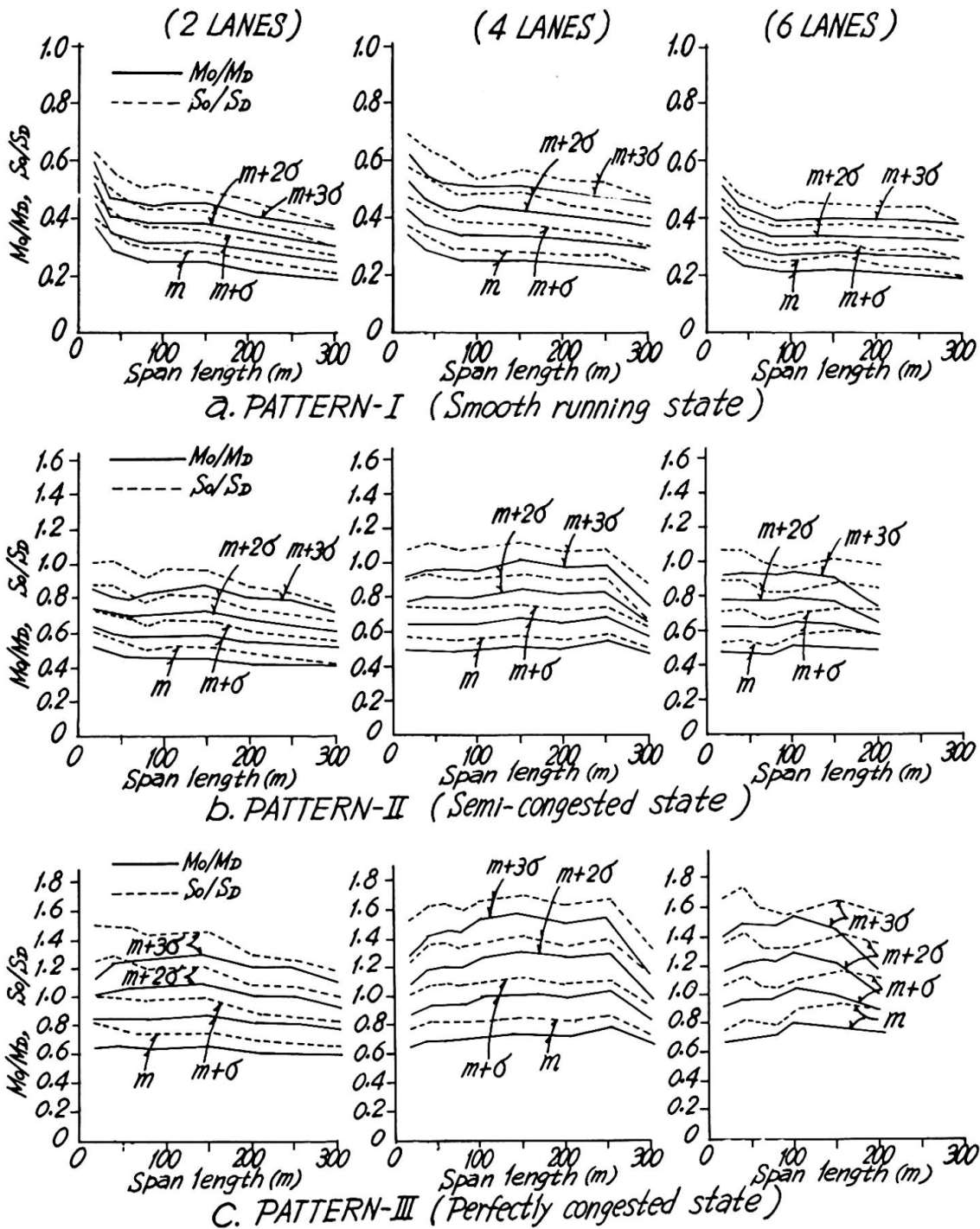

Fig. 10 Ratio of measured value to calculated value due to design load

The values of M_o/M_D and S_o/S_D thus obtained for all of observed points were gathered up for different number of lanes, and a histogram of M_o/M_D and S_o/S_D was drawn. The histogram showed that the form of distribution of M_o/M_D and S_o/S_D may be regarded as the normal distribution. Thereupon, the mean value "m" and the standard deviation " σ " of the values of M_o/M_D and S_o/S_D for different numbers of traffic lane and for different span lengths were calculated, then the relation between different expected magnitudes of the vehicle row load and their frequencies was presumed.

Fig. 10 was obtained in this way, indicating the features of magnitude of actual vehicles load in Japan. From Fig. 10, the following facts may be understood:

- 1) The magnitude of vehicle row load under normal traffic condition (Pattern I) is considerably low, the average value of the loading effects (moment and shear) in main girder is equal to 30%, at most, of those due to design live load regardless of the number of traffic lane and of span length, and even at the level of $(m+3\sigma)$, it is only 60%, at most, of the loading effects due to design live load.
- 2) Under the semi-congested state of traffic (Pattern II), that is usually occurred in Japan, the average value of the loading effect imposed in main girder ranges from 40 to 60% of that due to design live load, and the level of $(m+3\sigma)$, corresponds approximately to the level of design live load.
- 3) When vehicles are congested with clear distance of 1 m over the whole lanes (Pattern III), the average value of loading effect imposed in main girder is presumed to be 60 to 80% of that due to design live load, and the level of $(m+\sigma)$ corresponds approximately to the level of design live load.
- 4) S_o/S_D is usually larger than M_o/M_D . Namely, the current design live load in Japan is not well-balanced between bending moment and shearing force in main girder.

Fig. 11, comparison of loading effects due to design live load of well-known HS 20 Loading of AASHO (1969) and "Brücken Klasse 60" of DIN 1072 (1967) to those due to Japanese design live load, may facilitate understanding the consideration made in this report.

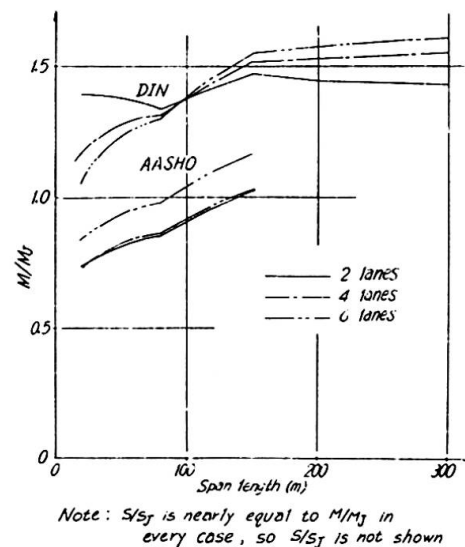

Fig. 11 Comparison of design loading effect in various countries

5. Conclusion

The following conclusion may be introduced concerning the load on highway bridges in Japan, on the basis of the results measured on the stress levels in bridge members, and on the wheel load and vehicle row load:

- 1) The live load stress imposed in main girder and main truss under usual traffic condition is 300 kg/cm^2 or so at most, which is considerably small as compared with the calculated design live load stress.
- 2) Vehicle row load under normal traffic condition is in considerably lower level as compared with the current design vehicle row load, but under the state in which the whole lanes are perfectly congested, there is a little chance that the vehicle row load may reach to the level of design load. Considering the fact that semi-congested state of traffic in which the half of traffic lanes are congested while the opposite half lanes are smooth is usually observed wherever in Japan, it seems to be suitable to determine the design load for main girder on the basis of such loading condition.
- 3) The relation between the weight and frequency of vehicle wheel load shows fairly big divergence according to area, but nearly constant trend on the same point. Generally speaking, the actual condition of wheel load is that it has no such allowance to design load as is seen in the vehicle row load, and the existence of such heavy wheel load exceeding design wheel load is amounting to a number which may not be ignored.
- 4) Since vehicle wheel load (single vehicle load) is in the severer condition than in the case of vehicle row load in comparison with the current design load, considerable unbalance of load carrying capacity between main girder and floor system has been arisen. In order to design a bridge of which each member is well balanced in strength, it will be necessary, so long as the current design load is employed, to use larger safety factor for the floor system than that for main girder.

References

- 1) Tetsuo Kunihiro, Minoru Ohta: "A Study on Stress Levels on Highway Bridges", Annual Meeting of Civil Engineering, Ministry of Construction, 1968 and 1969. (In Japanese)
- 2) Tetsuo Kunihiro, Minoru Ohta: "A Study on the Actual Condition of Traffic Load and its Effect on Highway Bridges", Report of Public Works Research Institute, Ministry of Construction, No. 626, Oct. 1970. (In Japanese)
- 3) Tetsuo Kunihiro, Hajime Asakura and Keiichi Inoue: "Study on Design Live Load", Report of Public Works Research Institute, Ministry of Construction, No. 701, Nov. 1971. (In Japanese)

Summary

As the result of our surveys of wheel load, row load of vehicles and of stress in bridge members, it was made clear that the magnitude of vehicle row load or corresponding stress in main girder has considerable allowance in comparison with the current design live load and corresponding stress, under any traffic loading condition except perfectly congested states, while the single vehicle load sometimes exceeds the design load and poses a problem in relation to the safety of slab and floor system.

Mesure des variations de réactions d'appuis d'ouvrages hyperstatiques en béton précontraint ou mixtes

Messungen von Variationen von Auflagerreaktionen bei statisch unbestimmten, vorgespannten oder Verbundbauwerken

Measuring of Variations of Support Reactions at Undetermined Prestressed or Mixed Structures

S. BRETONNIÈRE M. DIRUY
Laboratoire Central des Ponts et Chaussées
Paris, France

1. INTRODUCTION

L'étude expérimentale du comportement à long terme des ouvrages présente nombre de difficultés, eu égard aux techniques délicates de mesures in situ qu'elle implique. En ce qui concerne les ouvrages hyperstatiques, la mesure permanente des réactions d'appuis constitue un puissant moyen d'étude de la redistribution des contraintes due aux phénomènes à long terme imputables à la nature des matériaux constituants, à leur rhéologie (retrait et fluage du béton, relaxation des câbles de précontrainte) ainsi qu'aux variations climatiques environnantes (hygrométrie, température, ensoleillement).

De telles mesures nécessitent des capteurs devant répondre à des critères très particuliers :

- grande sensibilité, les variations de force à mesurer étant parfois très faibles par rapport à la charge permanente,
- absence totale de dérive, l'évolution des réactions devant pouvoir être suivie à très long terme,
- insensibilité aux sollicitations diverses d'ordre thermique ou mécanique (mouvements relatifs tablier-appui).

Les dynamomètres à déformation élastique présentent une dérive due au fluage du corps d'épreuve qui ne peut être éliminée que par une reprise périodique du zéro du capteur. Cette opération dans le cas des appuis de pont nécessite le déchargement du dynamomètre par un dispositif spécial reprenant les efforts. L'influence des sollicitations perturbatrices, mécaniques ou thermiques, est également difficile à éliminer d'où la mise au point d'un nouveau procédé qui utilise une cellule de charge ayant les qualités requises.

2. PRINCIPE DE LA CELLULE DE CHARGE

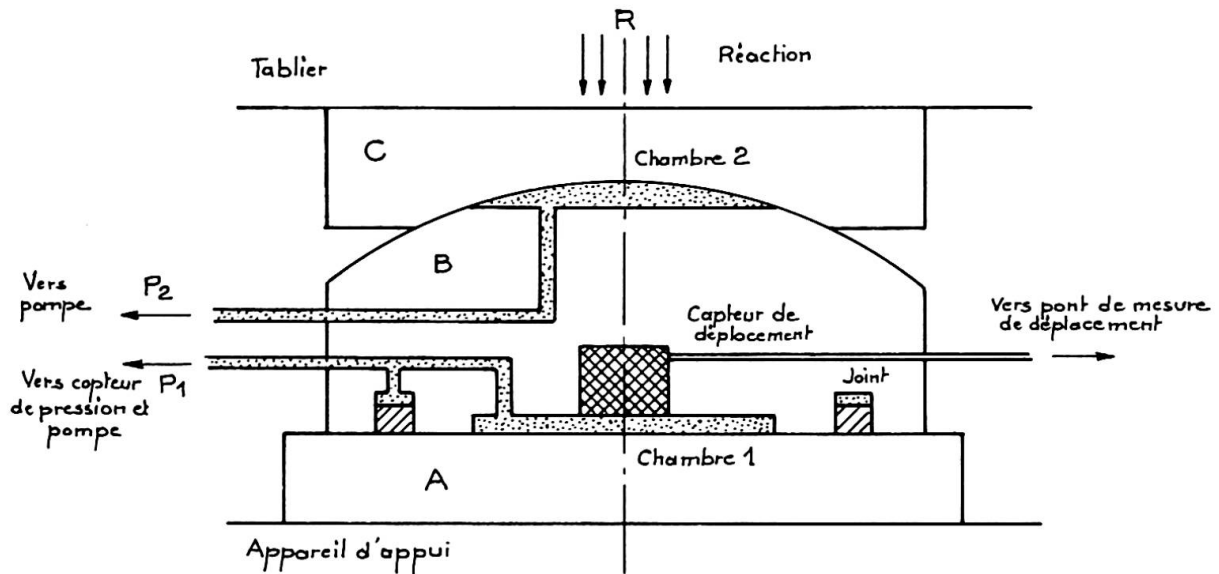
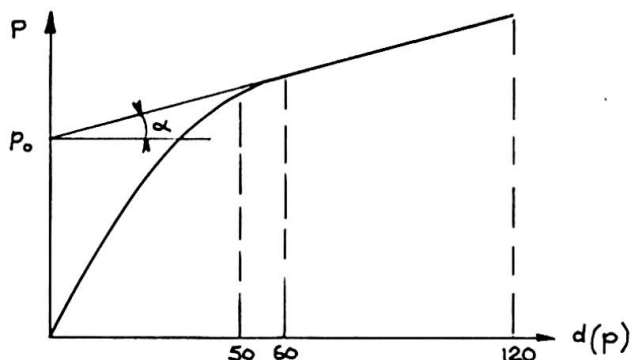

Fig. 1 - Schéma de fonctionnement

La cellule de charge directement interposée entre l'appui de l'ouvrage et le tablier, est constituée par 3 blocs rigides superposés (voir fig. 1 ci-dessus).

Ces blocs sont en contact par des faces planes rectifiées (A et B) ou par des surfaces sphériques (B et C). Deux chambres ménagées dans B peuvent être alimentées indépendamment sous pression d'huile au moyen d'une petite pompe à main.

La pression dans la chambre 1, développe à partir d'une certaine valeur une force qui équilibre la réaction d'appui et entraîne le soulèvement de B. Le déplacement relatif "d" de A et B, mesuré par un capteur incorporé à la cellule, est fonction de la pression hydraulique mesurée par un capteur indépendant de la cellule. Il

Fig. 2 - $p = f(d)$

d'étalonnage la valeur de la réaction d'appui.

faut atteindre un écartement de 50 à 60 μ pour éliminer tout contact entre B et C et obtenir, pour des déplacements inférieurs à 120 μ , une variation linéaire de p en fonction de d. La pente (α) de cette droite, traduisant la rigidité de l'ouvrage, est obtenue par des mesures de p de 10 μ en 10 μ . La pression p_0 pour $d = 0$, obtenue par extrapolation, fournit d'après la courbe

Toutefois le fonctionnement correct du dynamomètre n'est assuré que si la réaction d'appui R est centrée sur la chambre 1 sans aucun moment entre les blocs A et B. Dans ce but, avant toute mesure, la chambre 2 est mise sous pression d'huile pour permettre à l'élément C de rotuler sans frottement sur coussin d'huile.

3. CARACTERISTIQUES METROLOGIQUES

La force maximum mesurable avec une cellule de charge est fonction de la pression admissible dans la chambre et de sa surface.

La pression normale de service est de 250 bars et peut atteindre exceptionnellement 400 bars, ce qui permet de réaliser des cellules pour des forces de plusieurs centaines de tonnes.

Les erreurs de linéarité dues à la cellule de charge proviennent des variations possibles de la surface efficace de la chambre 1 ; le montage particulier du joint d'étanchéité permet de limiter cette erreur à 0,2 % pour des variations de pression comprises entre 2 bars et 400 bars.

La fidélité est très bonne et le pouvoir de résolution inférieur à 5.10^{-4} de la force mesurée. La cellule ne présente aucune hystérésis mesurable (vérifié lors d'étalonnage au 1/1000è près en laboratoire sur des cellules de force 100 KN).

Des variations de température entraînent des modifications de la section efficace de la chambre de l'ordre de 0,1 % pour $\Delta T = 40^{\circ}C$.

La précision des mesures est étroitement liée aux caractéristiques de la chaîne de mesure de pression qui peut être réétalonnée fréquemment. Pour des domaines de variation de force très étendus pouvant entraîner des variations de pression comprises entre 1 bar et 400 bars, il est nécessaire d'utiliser plusieurs capteurs d'étendues de mesure différentes. Dans le cas des réactions d'appuis les variations excèdent rarement ± 15 % et la pression nominale du capteur est donnée en conséquence.

Ce procédé peut fournir la valeur des réactions d'appui avec une précision inférieure à $\pm 0,2$ % à condition de disposer des moyens d'étalonnage en force.

4. UTILISATION PRATIQUE

Pour effectuer les mesures deux opérateurs sont nécessaires, l'un pour imposer la pression d'huile en fonction des déplacements désirés, l'autre pour mesurer cette pression grâce à un capteur à jauges de déformation et un pont de mesure statique de haute précision.

Pour les mesures de réactions d'appui, où chaque extrémité de travée est équipée de deux cellules de charge, on relève successivement les valeurs. Dans ces conditions la pente de la partie linéaire de la courbe $p = f(d)$ est surtout liée à la rigidité de torsion de l'ouvrage, la rigidité de flexion intervenant très peu.

5. APPLICATIONS

5.1 Modèle de pont mixte

Une ossature mixte acier-béton a fait l'objet d'une étude récente comportant notamment une série de mesures à moyen terme (quelques mois) ayant pour but une meilleure connaissance des effets du retrait de la dalle de béton sur le comportement de l'ouvrage. Ce dernier, construit dans le hall d'essais du Laboratoire Central des Ponts & Chaussées comportait 2 travées de 9,5 m (voir schéma fig. 3). Il reposait sur 6 appuis par l'intermédiaire de 6 pesons hydrauliques de capacité 100 KN (10 T) (photo de la fig. 3). Plusieurs sections étaient en outre équipées par divers moyens de mesures : jauges à fil résistant, extensomètres mécaniques et optiques, sondes de température, dispositifs optiques de mesure des flèches. Des dalles témoins constituées du même béton que celui du modèle devaient permettre de mesurer le retrait libre du matériau pris seul. Les mesures ont débuté en même temps que le coulage de la dalle. Les courbes de la fig. 4 résument les mesures de réactions d'appuis effectuées d'abord à intervalle très rapproché (1 h pendant la prise du béton) puis quotidiennement, ceci pendant 3 mois. La température et l'hygrométrie ambiantes furent maintenues sensiblement constantes pendant toute cette période ($t = 21^{\circ} \pm 2$ H_r = 60 % \pm 10 %). Les pesons étaient disposés de la façon suivante :

pesons 1 et 4 - appui extrémité gauche

pesons 5 et 6 - " " droite

pesons 2 et 3 - " central

On pouvait vérifier le poids du modèle (constant aux pertes d'eau du béton près) en faisant la somme des réactions d'appuis après chaque mesure.

Le calcul des réactions hyperstatiques effectué à partir des mesures extensométriques est en parfaite concordance avec les réactions mesurées à l'aide des pesons hydrauliques. On remarque pendant la prise du béton l'influence des phénomènes thermiques différentiels sur les réactions d'appuis. La perte de poids due au décoffrage apparaît également ainsi que les charges additionnelles qui furent ensuite ajoutées aux extrémités de l'ouvrage pour compenser un délestage trop important de ces appuis dû au retrait, et qui risquait d'annuler les réactions d'extrémité.

Par exploitation conjointe des valeurs des réactions d'appuis et des déformations mesurées, on a pu suivre l'évolution de divers paramètres, notamment celle du coefficient d'équivalence $\left(n = \frac{EA}{E_B} \right)$ et du retrait libre (ξ_r).

A la suite de ces essais il a été procédé à une dénivellation de l'appui central et à l'étude du fluage-relaxation consécutif. L'interprétation des mesures est en cours.

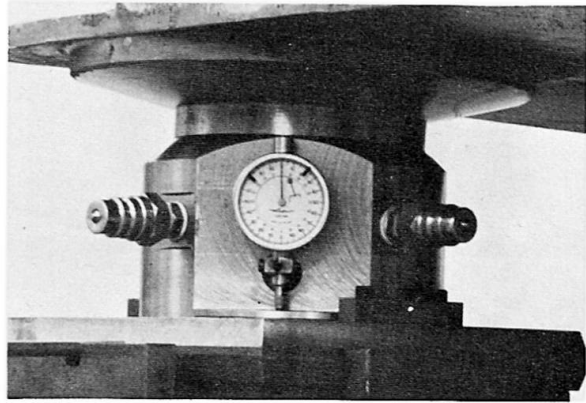
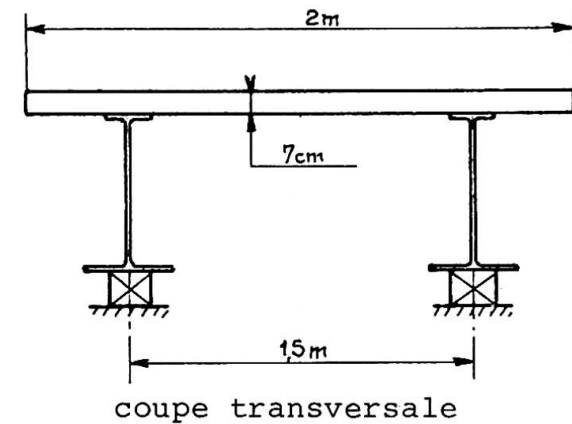

peson de 100 KN

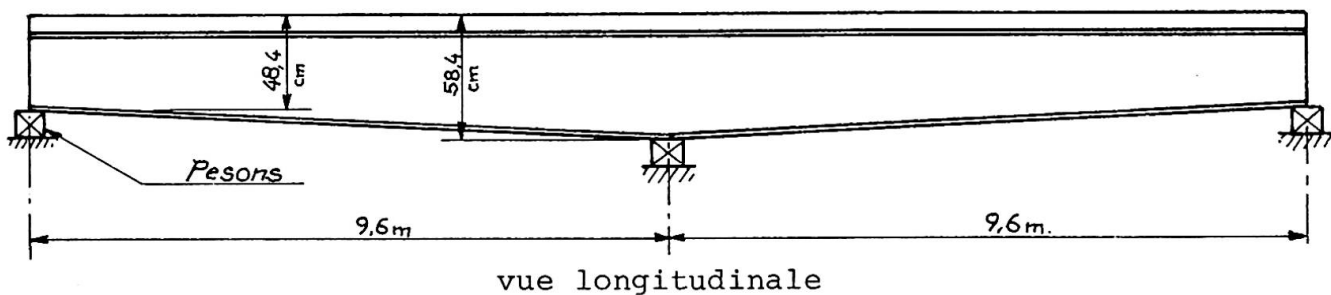

Fig. 3 - Essais d'une ossature mixte acier-béton

5.2 Ponts hyperstatiques en béton précontraint

5.2.1 Pont de Champigny-sur-Yonne

Ouvrage à 3 travées continues de 35 - 70 - 35 m de hauteur constante (voir fig. 5). Fin de construction : Avril 1970. Les culées de cet ouvrage ont été équipées chacune par 2 pesons hydrauliques de capacité 1000 KN (100 T), situés entre le tablier et les appuis néoprène-téflon. Les mesures qui ont été entreprises aussitôt après construction et sont poursuivies actuellement ont pour but principal de contribuer à l'étude de la redistribution des contraintes dues aux phénomènes de retrait-fluage-relaxation dans l'ouvrage. Elles sont effectuées une fois par mois environ. Les variations des réactions d'appuis mesurées sont modulées par les variations journalières de la température du béton. Celles-ci sont surtout dues à l'ensoleillement qui provoque un gradient thermique entre les parties supérieure et inférieure du tablier ; ce gradient amène une déformation différentielle des fibres longitudinales des hourdis et des âmes d'où variations de courbure de l'ouvrage et redistribution des réactions entre les piles et les culées. Le calcul des variations de réactions imputables à ce phénomène thermique est possible si l'on connaît la distribution des températures dans une section. On a donc placé convenablement des sondes thermiques qui renseignent à chaque instant sur la température du béton et permettent d'établir des corrections aux mesures de réactions sur culées.

Les courbes de la fig. 5 résument les mesures déjà effectuées. Après correction les courbes présentent une allure assez régulière

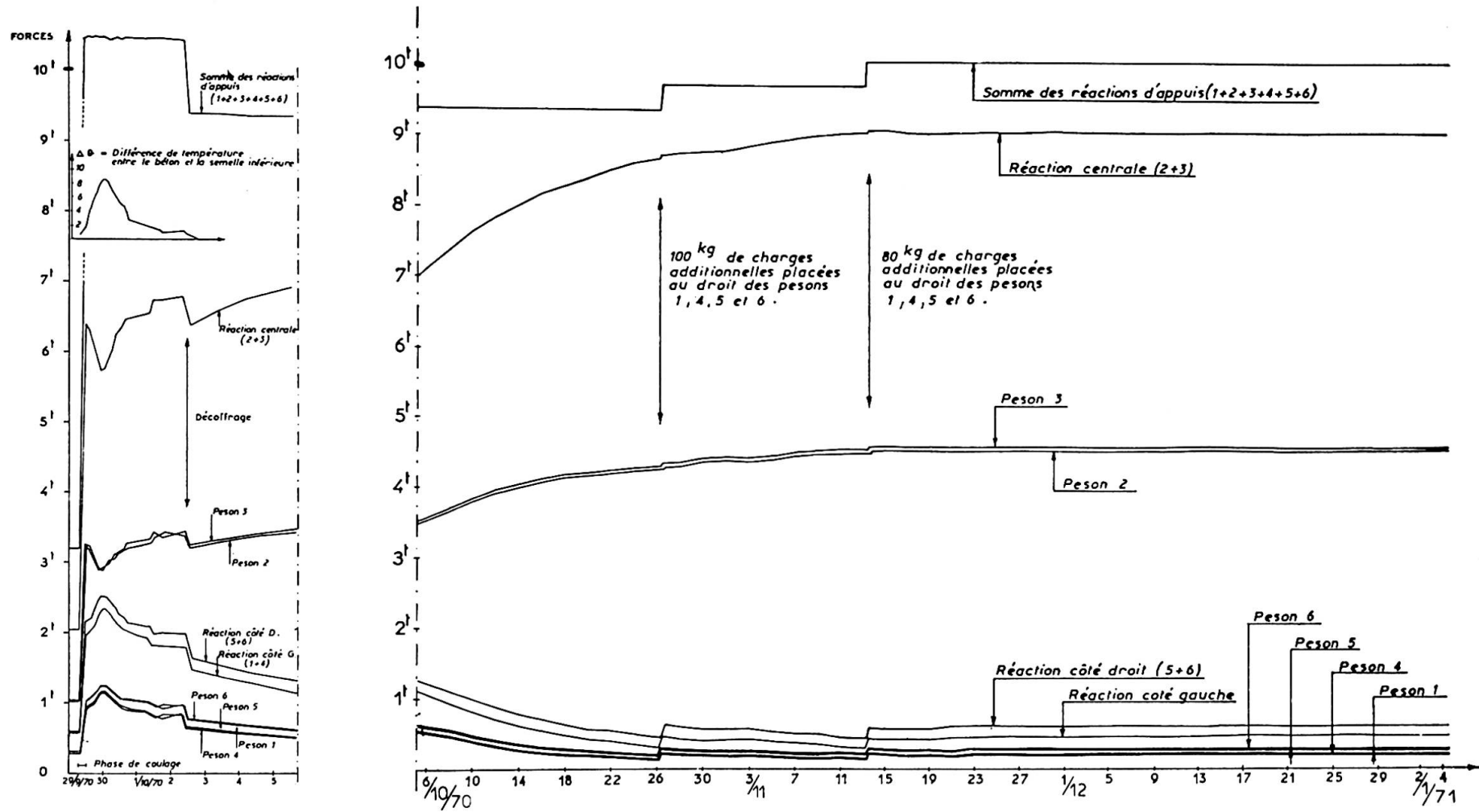

Fig 4. Modèle de pont mixte - Etude du retrait
Evolution des réactions d'appuis

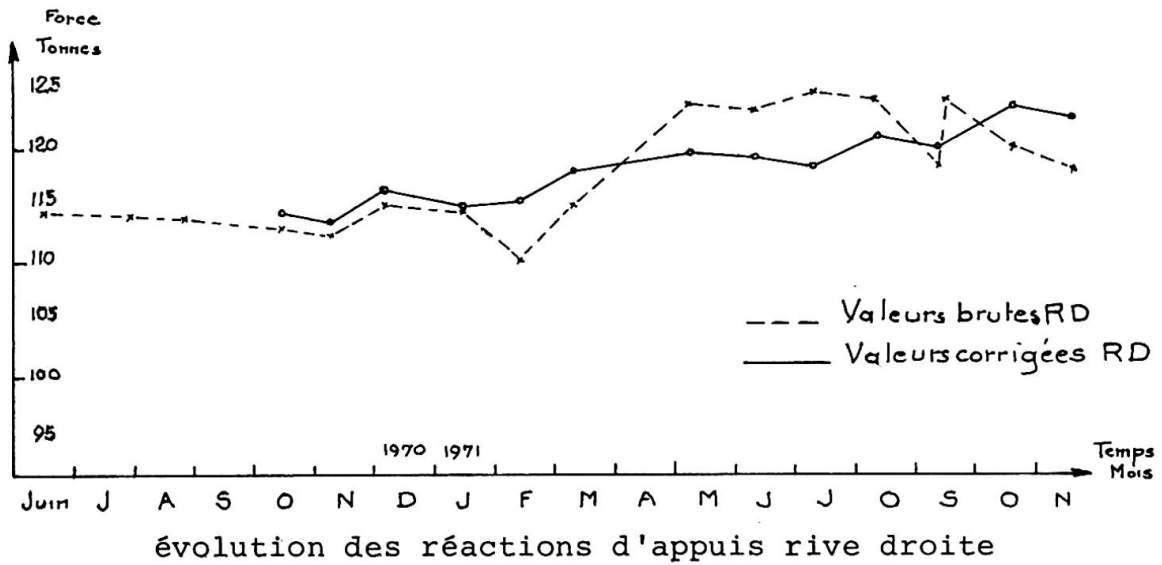
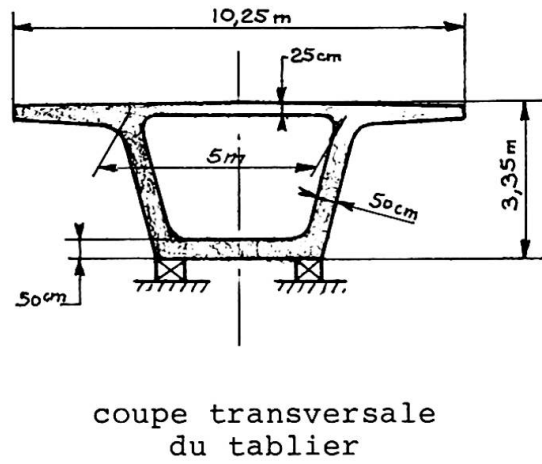
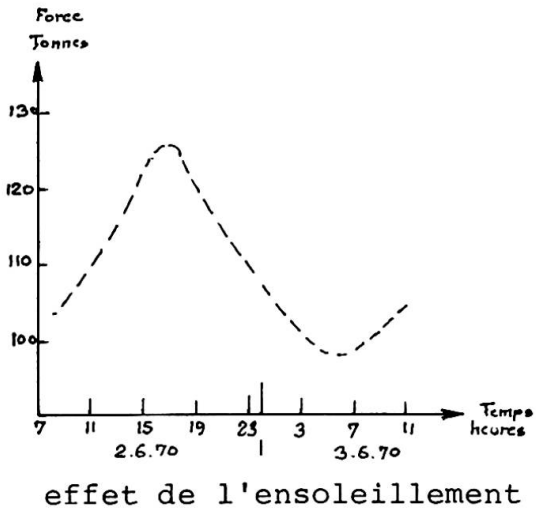
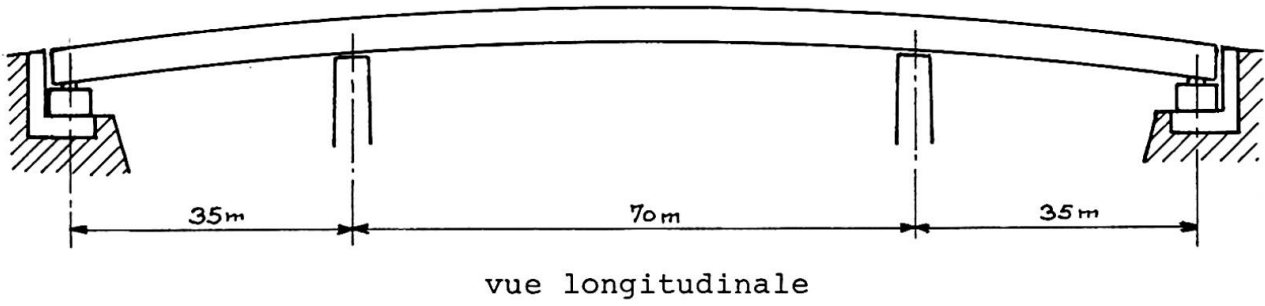

Fig. 5 - PONT DE CHAMPIGNY S/YONNE

ascendante (8 tonnes pour 1 an) qui peut être due à l'adaptation de l'ouvrage par fluage relaxation. L'interprétation de ces résultats ne fait que débiter et ne sera sérieusement engagée que lorsque les mesures auront été faites sur un laps de temps suffisant (2 ans environ).

Parallèlement, l'influence de l'ensoleillement sur l'ouvrage a été étudiée par des campagnes de mesures continues s'étendant sur 24 heures au moins. Au cours de l'une de ces campagnes des variations de 24 % de la réaction sur culée ont été constatées (fig. 5). Il s'agit probablement d'un cas extrême pour cet ouvrage mais des variations journalières de 15 ou 20 % sont courantes l'été. De telles constatations incitent assurément à la réflexion car l'ouvrage de Champigny n'est pas exceptionnel par sa situation géographique et nombre d'ouvrages de même type doivent subir des conditions climatiques plus sévères.

5.2.2 Pont de Tourville (sur la Seine)

Une étude analogue à celle concernant le pont de Champigny a été récemment entreprise sur un ouvrage en Béton Précontraint à 3 travées continues de 60 - 90 - 60 m , mais d'inertie variable.

Des pesons hydrauliques sont disposés sur les culées et la réaction par culée est de l'ordre de 2000 KN. Les mesures ont débuté en Mai 1971 et il est trop tôt pour en donner des résultats intéressants.

RESUME

Un dynamomètre hydraulique très sensible, sans dérive, et de haute fiabilité a été mis au point pour les mesures de réactions d'appuis des ouvrages.

Deux types d'applications en ont été faites :

1) Modèle de Pont Mixte étudié en hall d'essais -

Etude du retrait de la dalle de béton et des effets d'une dénivellation d'appuis.

2) Ouvrages en béton précontraint : Champigny-sur-Yonne et Tourville.

Etude de la redistribution des réactions d'appuis due à l'adaptation par fluage-relaxation de l'ouvrage.

Etude de l'influence des gradients thermiques sur la valeur des réactions d'appuis.

Via

Aerodynamic Behaviour of the Cable Stayed Bridge Toyosato Ohhashi

Comportement aérodynamique du pont haubané de Toyosato Ohhashi

Aerodynamisches Verhalten der seilabgespannten Toyosato-Ohhashi-Brücke

I. KONISHI

Prof. Dr.

Department of Civil Engineering
Kyoto University, Japan

S. KOMATSU

Prof. Dr.

Department of Civil Engineering
Osaka University, Japan

H. INOUE

Chief of Bridge Department
Osaka City, Japan

Abstract

This paper describes the aerodynamic behavior of a cable-stayed girder bridge. The wind tunnel experiment was conducted at relatively large Reynolds numbers by using a sectional model, which was 1/20 scale of a prototype.

The results show that the cable-stayed girder bridge with a trapezoidal closed cross section is always stable against a horizontal wind. However, some restricted motions could occur in an inclined wind to a horizontal direction with a comparatively low wind velocity and not so large amplitudes.

To make clear the aerodynamic behavior of the prototype in turbulent flow, the observation of atmospheric turbulences at the site where the prototype was constructed has been continued. By analyzing the structures in the atmospheric turbulence, it was recognized that the restricted motions, which had been observed in the wind tunnel experiment by using a smooth flow, would not occur in the prototype which was subjected to a natural wind fluctuating at random.

1 Introduction

The authors have been concerned about the response of flexible structures to a wind. Such structures as suspension bridges, tall stacks and cable-stayed girder bridges are known to be vulnerable to the effect of a wind. It has been known that a large number of bridges and stacks were damaged or destroyed by winds. Especially, the failure of the Tacoma Narrows Bridge which is a suspension bridge having a main span 853 meters long is known to be a remarkable accident. This bridge was destroyed by twisting vibrations which occurred at a relatively low wind speed of 19 m/s. After this accident, many treaties on aerodynamic behaviors of suspension bridges were presented.

F. Bleich¹⁾ suggested that the aerodynamic instability of suspension bridges showed a flutter as experienced with the wings, and applied to the suspension bridges the general theory previously applied to an aeroplane by Theodorsen and others. Many studies have been done since Bleich presented his report. According to the fact that in most cases suspension bridges have complex cross sectional shapes compared with wings, experimental values can not agree well with the theoretical results.

Recently, G. V. Parkinson²⁾ has suggested that a galloping oscillation of a

prismatic bar is to be considered as a nonlinear self-excited oscillation. And he stated that this theory well fit the experimental result for bluff cross section like The Tacoma Narrow Bridge.

The above-mentioned studies are mainly concerned with the aerodynamic stability of suspension bridges in a smooth flow. On the contrary, it has been pointed out that the effect of a turbulence of a natural wind must be considered. A. C. Davenport³⁾ has applied a noise theory to determine the response of a suspension bridge in a turbulent flow.

The aerodynamic behavior of a bridge is different from each other, because it has different cross sectional shape, dimensions and dynamic characteristics. So, none can predict exactly its behavior without carrying out a wind tunnel experiment.

The authors conducted a wind tunnel experiment to investigate the aerodynamic stability of a cable-stayed girder bridge, Toyosato Ohhashi Bridge. (Fig. 1). Catastrophic motions and restricted motions were observed in this experiment. It was concluded that the formers appeared at so high wind velocities and the latter would not occur in a natural wind.

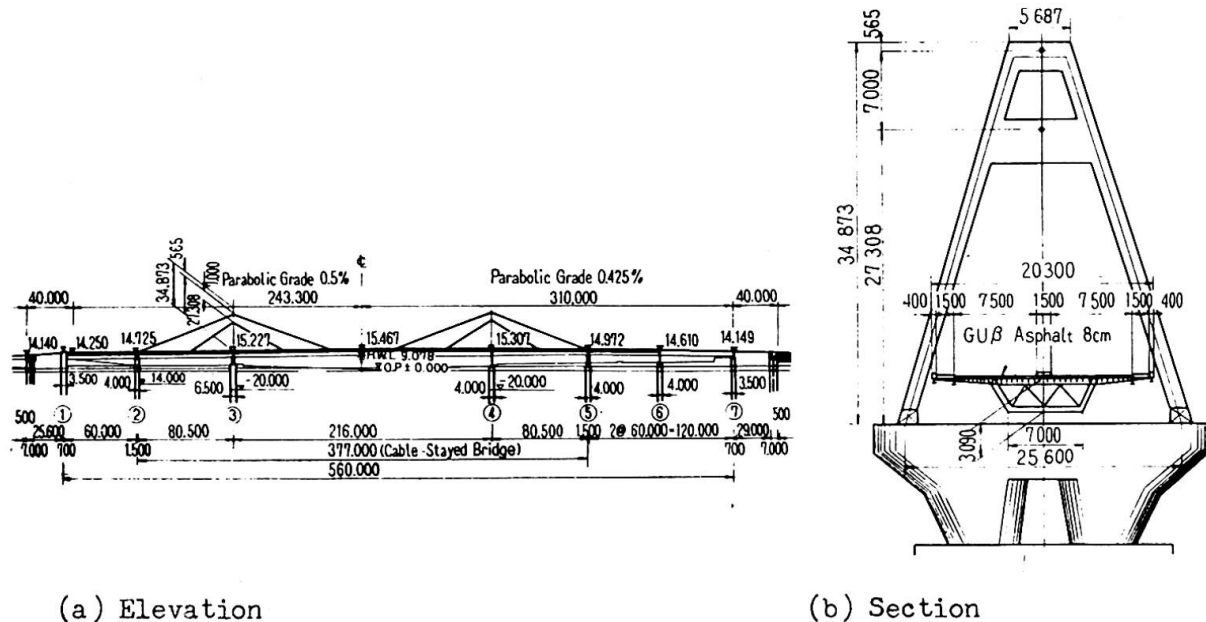

(a) Elevation (b) Section
Fig. 1 General view of Toyosato Ohhashi Bridge

2. Wind Tunnel Experiment

2.1 Model

To perform a wind tunnel experiment, such a sectional model as indicated in Fig. 2 was selected. The model was reduced to 1/20 of the prototype. It consists of two kinds of parts, one is the moving model of 2.5 meters long (4 in Fig. 2). It has a supporting shaft along the center axis of the model (2 in Fig. 2). The other parts are end plates and dummy models of 0.1 meter long (1 and 3 respectively in Fig. 2). The existence of the end plates and dummy models will be useful for eliminating three-dimensional effects of a wind stream.

The model was manufactured minutely so that it might resemble the prototype in detail, and its weight and moment of inertia were 68.8kg and 65.8kg.cm. sec. respectively.

2.2 Test Procedures

The model was supported horizontally in the wind tunnel by using eight coil springs so as to move vertically in the plane of the tunnel cross section and

led "restricted vibrations". Amplitude response curves of these phenomena are shown in Fig. 4 (a) and Fig. 4 (b).

Table 1. Summary of tests and results

Test number	α deg.	N_z c/s	N_θ c/s	V_c m/s	V_z m/s	T_z sec	V_θ m/s	T_θ sec	S_z	S_θ
A - 1	0	4.28	5.25	119	-	-	-	-	-	-
A - 2	0	3.08	3.82	108	-	-	-	-	-	-
A - 3	0	3.11	3.27	200	-	-	-	-	-	-
B - 1	3	4.25	5.25	67	4.3	480	24	100	0.18	0.17
B - 2	3	5.00	5.22	52	4.1	480	17	105	0.18	0.17
C - 1	5	1.30	2.66	72	4.6	169	30	55	0.11	0.15
C - 2	5	3.07	3.83	59	4.0	250	31	-	0.11	0.14
C - 3	5	3.08	3.16	46	4.1	244	38	51	0.11	0.15
C - 4	5	3.10	2.57	86	4.8	185	31	-	0.11	0.19

Note: N_z, N_θ : Frequency of model.
 V_c : Critical Velocity for catastrophic vibration.
 V_z, V_θ : Wind Velocity at which restricted vibration occur.
 T_z, T_θ : Time during which amplitude of restricted vibration is growing.
 S_z, S_θ : Strouhal number of model.
 Suffixes z and θ indicate vertical and rotational vibrations respectively.

It is well known that in case of the catastrophic vibration, the amplitudes grow rapidly in a short time to catastrophic magnitude from a rest position. On the contrary, the restricted vibrations observed in these tests were mild. It took a very long time to attain to stationary amplitudes.

The vertical or rotational vibration appeared independently with proper natural frequency. In some cases the both vibrations were observed at the same time, each frequency of the both vibrations were near its natural frequency and not combined together.

The damping coefficients of the model were changed and the corresponding response curves are shown in Fig.4 (a). The amplitudes decrease as the damping coefficients increase, but no strong relation between the amplitudes and the damping coefficient can be found in these tests.

The wind velocity at which the restricted vibration attains its maximum stationary amplitude is different in each test which has a different natural frequency and angle of attack. If the Strouhal numbers of the vibrating model are defined as follows: $S = N_h/V$, where N is vertical or rotational natural frequency

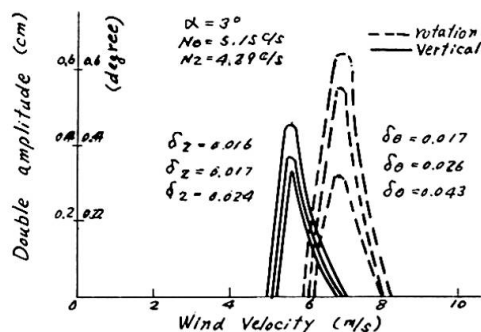

Fig.4 (a) Amplitude response curves

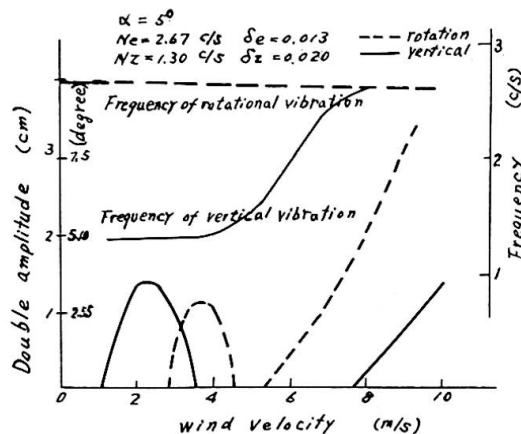

Fig.4 (b) Amplitude response curves

of the model, h shows horizontal projection of a height of the model and V is wind velocity at which the amplitude response attains the maximum value. In cases of angle of attack $\alpha = 5^\circ$, corresponding test numbers are C-1, 2, 3, in Table 1, the Strouhal numbers are $S \approx 0.17$ for the rotational vibrations and $S \approx 0.11$ for the vertical vibrations respectively. In cases of angle of attack $\alpha = 3^\circ$, corresponding test numbers are B-1, 2 in Table 1, the Strouhal numbers are $S \approx 0.17$ for the both of the vertical and rotational vibrations.

K. Klöppel⁴⁾ and T. Yamaguchi⁵⁾ measured the Strouhal numbers of the models whose cross sectional shapes were similar to the model handled in this paper. They showed that the Strouhal numbers of the models were about $S = 0.12$. Their models were simply designed and made of wooden plates, on the contrary the model herein was closely resembled to a prototype having handrails, wheel guards, etc. According to the cross sectional shape of the models, the frequencies of wake vortices discharged from the models seem to be different from each other sensitively. Those of the model herein were slightly higher than those of their models, and the Strouhal numbers of the model herein were slightly enlarged.

3. Safety of Prototype

3.1 Critical Velocities for Catastrophic Vibrations

From the previous section the critical velocities at which the model caused catastrophic vibration were obtained. The models were arranged to satisfy the aerodynamic similarity, so the critical velocities of the model prototype could be calculated from those of the model. The critical velocities of the prototype are shown in Table 1. In cases of angle of attack $\alpha = 0^\circ$, the critical velocities are very high. If a safety factor for the critical velocity of a catastrophic vibration is assumed as $f = 1.2^*$, the allowable maximum wind velocity is estimated from the critical velocity in Table 1 to be $V_a = V_c/f = V_c/1.2$. In cases of angles of attack $\alpha = 3^\circ$ and $\alpha = 5^\circ$, the critical velocities are relatively low compared with a stormy wind velocity.

It will be necessary to examine if such critical velocities are dangerous for the prototype or not. It is useful to apply the relation⁶⁾ between angle of attack and velocity of a natural wind observed at the Severn Bridge in England and the Akashi Narrows Bridge in Japan to examine the above question. (Fig.5). According to the results of the above observations, the maximum wind velocity drops as the angle of attack increases, the maximum wind velocities are found to be 27 m/s and 10 m/s for the angles of attack of the wind $\alpha = 3^\circ$ and 5° respectively, where the velocities are the average values during 30 seconds.

The prototype has been constructed at an open field, so that the above-mentioned fact is applicable to this case. Namely, the prototype does not cause a catastrophic vibration corresponding to the model which has a positive angle of attack.

*) This value is specified at "Standard Specification for the design of the Honshu-Shikoku Renrakukyo (Long Span Suspension Bridge) against wind" 1967 (in Japanese).

3.2 Safety against restricted vibration

It has been studied that a restricted vibration appears at a very low wind velocity, for example a vertical vibration occurs at the wind velocity $V = 4\text{m/s}$ if a natural wind flows having a positive angle of attack $\alpha = 5^\circ$.

The amplitudes of restricted vibrations of the prototype were predicted from the experimental data, using the theory by F. B. Farquarson⁷⁾. The theory is based on the following assumption that the aerodynamic damping in the wind of a given velocity can be expressed by a power series equation of amplitude. The amplitudes of the prototype predicted with the above theory are shown in

Table 2. In this calculation a vibration mode of the prototype was assumed to be of the first mode. In cases of vertical vibrations the amplitudes of the maximum fiber stresses are not so large, and in cases of rotational vibrations the amplitudes of the maximum shearing stresses are relatively large, however the corresponding wind velocities at which the amplitudes attain the maximum values are higher than those of the vertical vibrations.

Table 2. Maximum amplitudes and stresses of prototype due to restricted vibrations and corresponding wind velocities.

Test number	α deg	Vertical Vibration			Rotational Vibration		
		η max cm	σ max kg/cm ²	V m/s	θ max deg	τ max kg/cm ²	V m/s
B - 1	3	2.6	32	4.2	0.36	359	30
B - 2	3	5.1	62	4.6	0.28	244	30
C - 1	5	14.5	177	7.6	0.80	700	34
C - 2	5	13.9	170	8.3	-	-	40
C - 3	5	11.0	134	8.1	0.38	311	37
C - 4	5	11.6	141	8.5	0.52	455	30

As indicated above, the vertical restricted vibrations occur at very low wind velocities when the wind has an angle of attack. It is doubtful if the prototype actually vibrates in a natural wind as indicated in the next section, because the natural wind flows horizontally in average for time and space at an open field, and has an angle of attack fluctuating positively and negatively at random with a relatively high frequency. On the other hand, the restricted vibrations grow very slowly, it takes more than 100 seconds long to attain the maximum stationary amplitude from the rest position in the cases of the vertical vibrations.

4. Aerodynamic Behavior of Prototype in Turbulent Flow

To see whether the above assumption is true or not, the observations of natural wind have been made at the point where the prototype was constructed, and at the same time the behavior of the bridge due to wind has been observed.

No restricted vibration has been able to be observed so far. Vertical components of the wind were analyzed with the observed data. One of these is shown in Fig.6, in which the full lines show the theoretical values calculated from the power spectrum of vertical component of a wind proposed by H. A. Panofsky and R. A. McCormic⁸). This figure shows the maximum angle of attack of a wind as a function of time during which an angle of attack is averaged. In this case the mean wind velocity is about 10 m/s. The angle of attack of a wind decreases as the time increases.

It can be concluded that a wind does not continue to flow in the constant direction at negative or positive angle of attack for a long time,

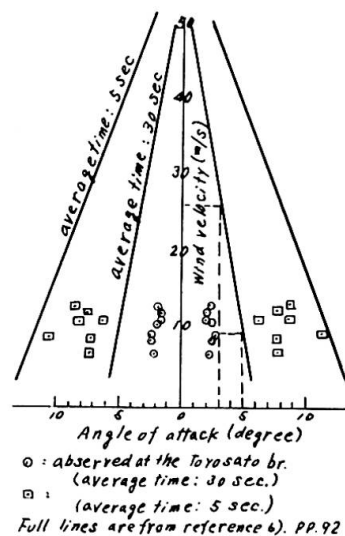

Fig.5. Wind velocity and angle of attack.

and such a wind can not develop a restricted vibration at all. That is to say, it is recognized that there is no natural wind which enables the prototype to cause the restricted vibration which was observed in the wind tunnel experiment.

5. Conclusions

The following results could be obtained from the wind tunnel experiment concerning to the cable-stayed girder bridge.

(1) When no angle of attack of a wind exists, this type of bridge is considerably stable in terms of an aerodynamic stability.

(2) When a positive angle of attack of stationary wind exists the model gives rise to the restricted vibrations at very low wind velocities.

(3) Both vertical and rotational amplitudes of the restricted vibrations of the prototype in the stationary wind were predicted. As a result, it was found that these amplitudes would not grow to a significant quantity.

(4) It takes more than 100 seconds for the vibration to attain a maximum stationary amplitude from its rest position in case of vertical vibration of the prototype.

(5) From the field measurements, it was found that a natural wind could not cause the restricted vibrations. Besides, no vibration of the prototype has been observed up to now.

Acknowledgment

Particular thanks are due to Mr. A. Matsukawa and H. Kobayashi who cooperated with us throughout this study.

References

- (1) F. Bleich, Trans. ASCE, Vol. 114, No.2385 (1949).
- (2) G. V. Perkinson and N. P. H. Brooks, Trans. ASME, Vol. 83 (1961) pp. 252--258.
- (3) A. G. Davenport, Proc. ICE, Vol.19 (1961) pp.449--472.
- (4) K. Klöppel and F. Thiele, Der Stahlbau, H-12 (1967) pp.353--365.
- (5) T. Yamaguchi, et al, Mitsubishi Heavy Industries Tech. Review, Vol. 7, No.7 (1970), (in Japanese).
- (6) K. Aoki, et al, "Supplementary Note to First Rep. of Tech. Investigation on the Honshu-Shikoku Br." JSCE, Tokyo, Japan (1964), (in Japanese) pp.91--92.
- (7) F. B. Farquarson, et al, Bull. Univ. Washington, Eng. Station, No.116, Part V (1949--1954) pp.13--31.
- (8) H. A. Panofsky and R. A. McCormic, Inst. Aero. Sci., Rep. Vol. 59, No.6 (1959).

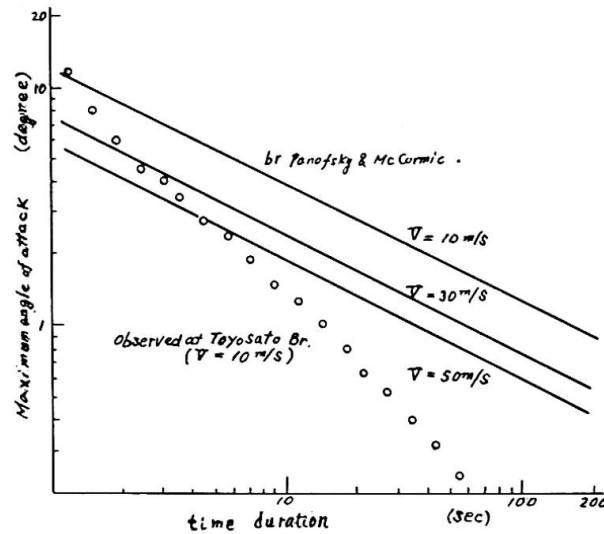

Fig.6 Maximum angle of attack of natural wind.

Summary

To make clear the aerodynamic characteristics of a cable-stayed bridge (Toyosato Ohhashi Bridge) with trapezoidal cross section, the wind tunnel investigation has been carried out using two-dimensional model with linear scale of 1:20 in comparatively high Reynold's number.

The investigation has shown that the aerodynamic instability will not be induced in high wind which may be experienced at the site of actual bridge.

The small stationary amplitude vibrations, so-called restricted vibrations, grew up slowly in smooth airflow inclined upwards 5 degrees to horizontal. However, it is recognized from studying the three-dimensional effect of actual bridge that the restricted vibration may not be considered to occur in turbulent airflow such as natural wind which has been measured at the site.