

Design for durability

Autor(en): **Pakvor, Aleksandar**

Objektyp: **Article**

Zeitschrift: **IABSE congress report = Rapport du congrès AIPC = IVBH
Kongressbericht**

Band (Jahr): **14 (1992)**

PDF erstellt am: **22.06.2024**

Persistenter Link: <https://doi.org/10.5169/seals-853274>

Nutzungsbedingungen

Die ETH-Bibliothek ist Anbieterin der digitalisierten Zeitschriften. Sie besitzt keine Urheberrechte an den Inhalten der Zeitschriften. Die Rechte liegen in der Regel bei den Herausgebern.

Die auf der Plattform e-periodica veröffentlichten Dokumente stehen für nicht-kommerzielle Zwecke in Lehre und Forschung sowie für die private Nutzung frei zur Verfügung. Einzelne Dateien oder Ausdrucke aus diesem Angebot können zusammen mit diesen Nutzungsbedingungen und den korrekten Herkunftsbezeichnungen weitergegeben werden.

Das Veröffentlichen von Bildern in Print- und Online-Publikationen ist nur mit vorheriger Genehmigung der Rechteinhaber erlaubt. Die systematische Speicherung von Teilen des elektronischen Angebots auf anderen Servern bedarf ebenfalls des schriftlichen Einverständnisses der Rechteinhaber.

Haftungsausschluss

Alle Angaben erfolgen ohne Gewähr für Vollständigkeit oder Richtigkeit. Es wird keine Haftung übernommen für Schäden durch die Verwendung von Informationen aus diesem Online-Angebot oder durch das Fehlen von Informationen. Dies gilt auch für Inhalte Dritter, die über dieses Angebot zugänglich sind.

DESIGN FOR DURABILITY

ALEKSANDAR PAKVOR

Full Professor, B.Civ.Eng., M.Sc., Ph.D.

Department of Civil Engineering
University of Belgrade, Yugoslavia

SUMMARY

Durability of concrete structures, from both technical and economic aspects has become one of the basic civil engineering tasks. In order to achieve durable concrete structures, measures should be taken for prevention, decrease or slow-down of their deterioration processes. The measures should be taken in all phases of creation and life of the structure. A long service life of the structure could be achieved by high level of design and construction, by adequate operation, regular maintenance and due repairs and rehabilitations. The basic factors of concrete structure deterioration are: presence of water and moisture, environmental aggressivity, compactness and thickness of the concrete cover, compactness of grouting for the protection of prestressing wires and the width of cracks. The analysis of these factors leads to the measures that should be taken during the design, construction, operation and maintenance of concrete structures.



GENERAL

Following the current principles, *concrete structures*, either reinforced or prestressed, should have the corresponding *reliability* at every moment of their operation. It means that the concrete structures should have the sufficient *safety*, the required *serviceability* and the necessary *durability*.

From the historical point of view the analysis of concrete structures *durability* is the youngest one. The reasons not to sufficiently seriously consider the durability of concrete structures since the time they have first appeared can surely be found in the fact that they are very *durable*. At the beginning, many people have wrongly taken them for eternal thus considering their maintenance not necessary.

Nowadays, however, when numerous concrete structures are of considerable age or at the end of their service life, durability problems are paid great attention to. Unfortunately, in the near past sudden unexpected catastrophic failures of poorly maintained structures took place. *Durability, maintenance, rehabilitation and strengthening* of the existing concrete structures, especially of bridges, of numerous structures subjected to aggressive effects, has become one of the basic civil engineering tasks. Scientists and experts all over the world are engaged in studying those problems from both *technical* and *economic* aspects.

SERVICE LIFE

The *service life* of a concrete structure is a period of time during which it has the sufficient *safety* and the required *serviceability*.

The *designed service life* can be achieved with different scope of rehabilitations, Figure 1.

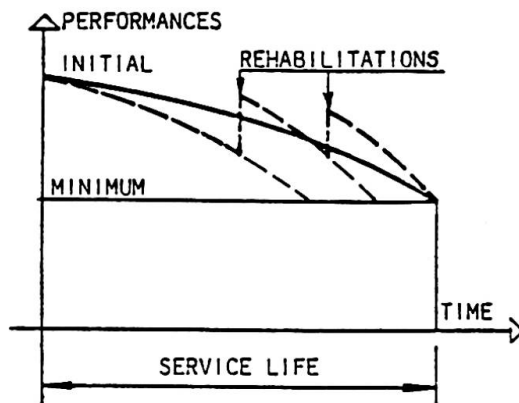

Fig. 1 - SERVICE LIFE

The better the quality of structure which is subjected to regular maintenance, the lower the decrease of its performances from the initial to the minimum required values at the end of the service life.

In order to achieve the same service life for a lower quality structure which is not regularly maintained as for the higher quality, regularly maintained, more frequent rehabilitations are necessary. That, certainly, requires *higher* total expenses.

A *long service life* of the structure could be achieved by high level of design and construction, by adequate operation, regular maintenance and due repairs and rehabilitations.

During the *design*, it is difficult to establish the *service life* of a structure because the requirements that it has to meet during the operation period are increased with time. It is not easy to rightly assess the future development of the technology many years in advance.

The service life of a concrete structure is much longer in comparison with the service life of the equipment and vehicles transmitting their effects onto it. It is realistic to expect the structure to last a number of generations of the equipment and vehicles with possible adaptations and strengthenings of the structure.

A structure reaches its *real service life*, which due to numerous unpredictable factors does not equal the design service life, when the expenses of its further maintenance in the condition of sufficient safety and the required serviceability exceed the expenses of maintenance which, during the operation period, have been considered acceptable.

It is absolutely clear that the concrete structure, when it *reaches* its *service life* should *not be immediately replaced*. That is, however, the moment when it should be analyzed in detail and estimated if the indispensable rehabilitation including the future maintenance is technically justified and economically more favourable than the construction of a new structure. That is the time when the *decision* should be made on *future destiny* of the existing structure.

DURABILITY

Although they are very durable, concrete structures, sooner or later, start showing the signs of *deterioration*. The appearance and the development of the deterioration process come as a consequence of very *different causes*.

The most dangerous form of concrete structures deterioration is the *deterioration of steel*. Full attention must be paid to the *permanent corrosion protection* of the reinforcement and prestressing wires. In the highly-alkaline mass of concrete, they are fully protected by *passivation*.

Deterioration of concrete, physical, chemical or biological, is less dangerous. However, it can significantly influence the increase of the deterioration of steel.

The required *durability* of concrete structures should be achieved by taking a series of *measures*. They refer to *prevention, decrease or slow-down* of the *deterioration process*, as well as to due *repairs and rehabilitations* of the damages.

In order to achieve the purpose, in the best way possible, but from engineering and economical points of view, a series of measures should be taken in *all phases of creation and life* of each structure:

- During the *design* (gathering of the detailed relevant data on the location, the selection of an adequate structural conception, the selection of the corresponding structural materials, the application of the appropriate computation models, dimensioning according to all limit states, correct solving of the structural details);
- During the *construction* (selection of adequate construction methods, realization of the structure in accordance with the design, realization of the required preciseness of the structural geometry and the position of reinforcement and tendons, the application of the designed quality of the materials, the selection of adequate composition of concrete, correct mixing, transportation, placement and curing of concrete in order to obtain the required quality, realization of the concrete cover of the required thickness and compactness, good grouting of



tendons, correct continuations of concrete placement);

- During the *operation* (provision of the design use of the structure, protection from overloading and undesigned actions);
- During the *maintenance* (regular follow up of the condition and behaviour of the structure, due repair and rehabilitation).

The *designer*, the *contractor*, the *owner* and the *user* should take care of the execution of those measures.

WATER AND MOISTURE

The presence of *water* and *moisture* make the most dangerous cause for the appearance and development of the deterioration process of concrete structures. Practically, in all deterioration processes, water can be found and it plays a very important role.

In order to provide *durability*, measures should be taken to prevent or to decrease retaining of water on the surface and its penetration into the concrete. Water should be drained off as soon as possible.

During the *design*, a secure *waterproofing* and efficient *draining system* should be planned.

The *shapes* of concrete surfaces exposed to atmospheric waters should be selected so as to prevent retaining of water and to enable its quickest possible draining, Figure 2.

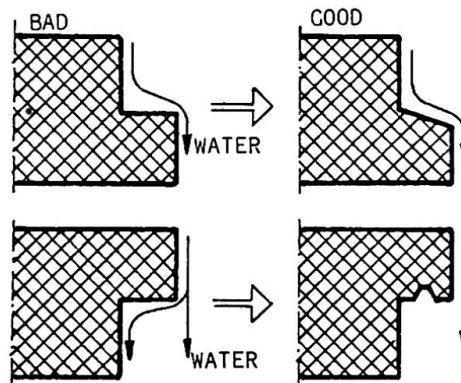

Fig. 2 - SHAPE OF CONCRETE SURFACES

Smooth surfaces are much better than the rough ones.

If possible, concrete should be *protected* from direct *splashing* by water due to passing vehicles, Figure 3.

During the winter, such water can even contain defreezing salt. Easy *replacement* should be designed for the members which are difficult to protect.

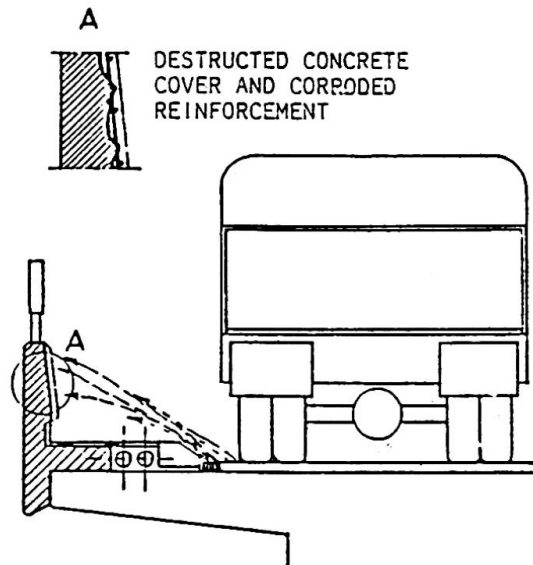

Fig.3 - SPLASHING DUE VEHICLES

Asphalt pavement on concrete bridges is not, as it has been thought earlier, sufficient to prevent the penetration of water, containing defreezing salt during the winter, to the deck, and, if it is cracked through it, too, Figure 4.

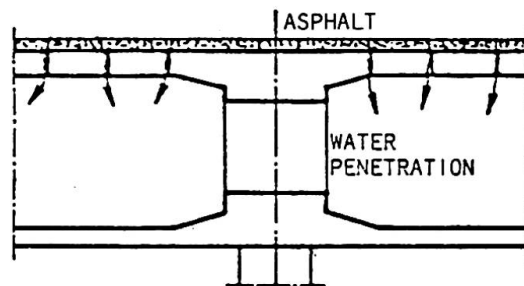

Fig.4 - BRIDGE DECK WITHOUT WATERPROOFING

It is indispensable to make *waterproofing* between the pavement and the deck.

The *draining system* should be so designed as to safely and quickly drain the water and to be easily accessible for maintenance. The draining tubes should not be embedded into the concrete mass, Figure 5.

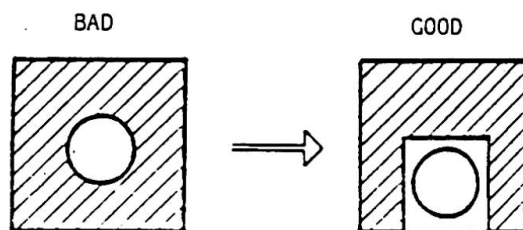

Fig. 5 - DRAINING TUBES

Beside good *construction* and correct *operation*, regular control of *waterproofing* and *draining system* functioning should be undertaken during the *maintenance*.



Possible *damages* or *cloggings* should be immediately removed. The penetration of water from damaged gullies and draining tubes to the box girder was one of main causes of damages, for a concrete bridge, Figure 6.

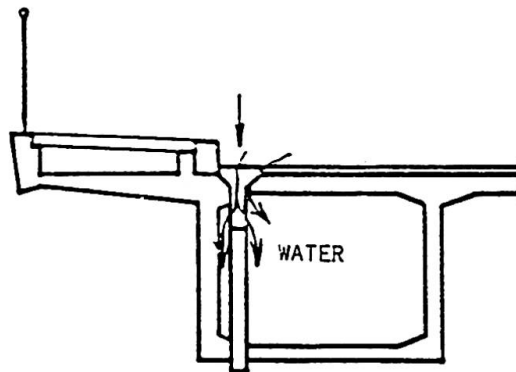

Fig. 6 - DAMAGED DRAINING SYSTEM

In the box girders, *openings* for quick draining of possibly penetrated water, as well as for aeration should be designed.

AGGRESSIVE ENVIRONMENT

The deterioration process of concrete structures is highly influenced by *aggressive environment*.

The most frequent is *chloride aggressivity*. It is caused by the presence of *defreezing salt* on bridges during the winter, or due to presence of *sea salt* on the structures in coastal regions. Chloride ions decrease alkalinity of concrete so depassivation takes place together with the corrosion of steel.

In industrial structures, concrete can get into contact with very aggressive *inorganic acids* (hydrochloric, sulphuric, nitric) or with *organic acids* (lactic, acetic). During the production of fertilizers, concrete is endangered by *ammonium salts*. Such aggressive substances as well as *magnesium salts* from the sea and ground waters including *soft water* chemically react with *all calcium components* of the hardened cement creating expansion compound which are washed out from the surface of the concrete causing its deterioration.

Sulphate aggressivity on the concrete causes chemical reaction of sulphate ions with *aluminat component* of the hardened cement, creating expansion compound resulting in the appearance of cracks.

Alkalies in contact with concrete *silicates* and *carbonates* from aggregates. *Alkali-silica* and *alkali-carbonate* reactions lead to expansion, resulting in appearance of cracks.

In the box girder of a concrete bridge, into which the entrance of birds through the openings without doors or wire networks was not prevented, thick layers of birds excrement, eggs and similar impurities were found, Figure 7.

The lower chord of that box girder especially in the vicinity of incorrect draining tubes, was so damaged that it was inevitable to replace it, Figure 8.

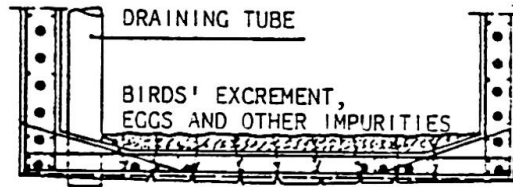

Fig. 7 - PRESENCE OF BIRDS IN THE BOX GIRDER

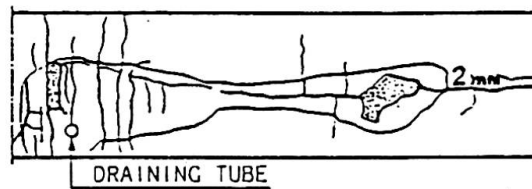

Fig. 8 - VERY DAMAGED LOWER CHORD

The prestressing wires taken from that lower chord were very much corroded and even completely broken, Figure 9.

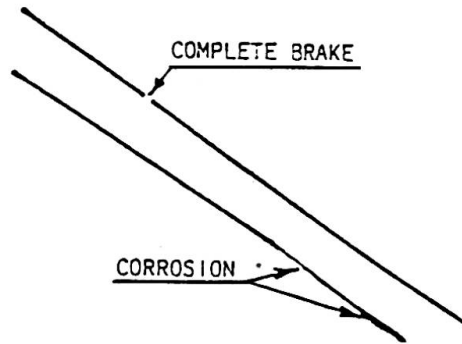

Fig. 9 - VERY CORRODED PRESTRESSING WIRES

Very much corroded reinforcement and an outstanding taking off of concrete on poorly made ceiling in very wet aggressive surroundings of a swimming pool in a spa are shown in Figure 10.

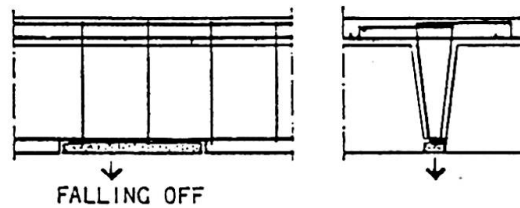

Fig. 10 - VERY MUCH DAMAGED CEILING

During the *design and construction*, it is necessary to take measures to permanently *protect* the concrete structures from aggressive environment. Depending on the kind of aggressive environment, the corresponding kinds of *cement and aggregates* should be selected - their deterioration resistance should be higher.

During the *operation*, measures should be taken to *decrease* the aggressivity, and during the *maintenance*, measures should be taken to *control* the structures together with the measures to *remove* the deposited aggressive substances.



CONCRETE COVER

An essential influence on the concrete structures deterioration has the state of the *concrete cover*, as well as the state of *grouting* for prestressing wire protection.

Porous, thin, poorly made and damaged concrete cover directly influences the *corrosion* of the reinforcement.

Moisture containing aggressive substances penetrated through porous and thin concrete cover causes reinforcement corrosion visible by the appearance of rust spots on the concrete surface. The corroded reinforcement swells causing longitudinal cracks and falling off of the concrete cover. The process is a progressive one as longitudinal cracks and separation of concrete intensify the penetration of moisture containing aggressive substances to the reinforcement.

Porous and poorly made concrete cover enables *physical deterioration* of concrete structures, due to *frost, erosion or cavities*.

Porous, poorly made and partly not placed grouting for the protection of prestressing wires directly influences their *corrosion*.

Poorly grouted and partly not grouted tendons of the box girder of a bridge were the causes of intensive corrosion of prestressing wires, Figure 11.

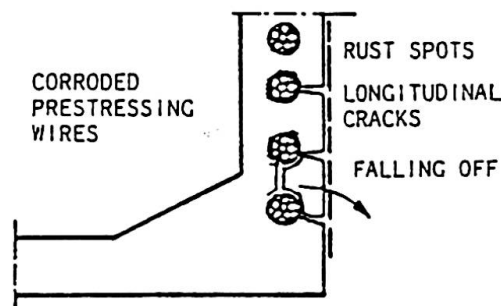

Fig. 11 - POORLY GROUDED TENDONS

In the past, prestressing wires were frequently conducted through the inside of the box girder, with a good concrete protection along its length. However, it was difficult to achieve a good protection at its entrance to the deck. Poorly made concrete protection, beside lack of waterproofing and the cracked deck of a concrete bridge, has caused the penetration of water containing defreezing salt, intensive corrosion and the complete break of all prestressing wires of one of four existing groups, Figure 12.

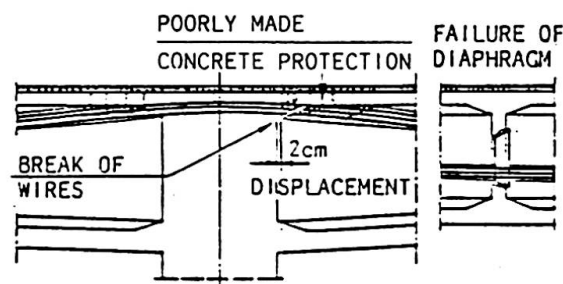

Fig. 12 - POORLY MADE CONCRETE PROTECTION

That had caused a serious rehabilitation of the bridge.

Poorly sealed grouting control tubes of the prestressed hangers of a concrete bridge have enabled the penetration of water along the tendons, Figure 13.

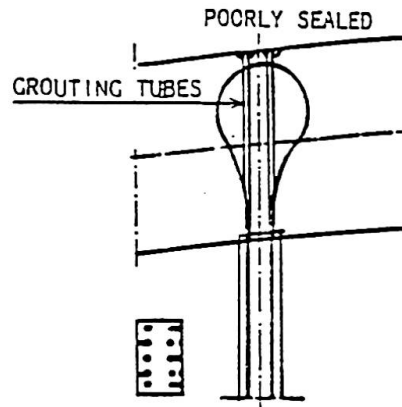

Fig. 13 - POORLY SEALED GROUTING TUBES

Very aggressive corrosion of prestressing wires took place together with the longitudinal cracks in the hangers. This later led to the rehabilitation of the bridge hangers.

It is essential for *durability* of concrete structures to realize, during their *design* and *construction*, the best possible *compactness* and the necessary *thickness* of the *concrete cover*. *Grouting* for the protection of prestressing wires should be *compact* and *well made* during the *whole length* of the tendons.

Achievement of the necessary *compactness* of the concrete cover depends on a series of factors regarding the *technology* of concrete as are kind, quality and quantity of cement, kind and grain size distribution of the aggregates, water cement ratio, kinds and quantities of possible admixtures, methods of mixing, transportation placement and curing of concrete.

During the *maintenance*, it is very important to *control* the concrete cover and the grout for the protection of prestressing wires.

The appearance of *rust*, *lime* or *water spots* on the concrete surface, as well as the appearance of *blistering*, *separation* and *falling off* of the concrete cover, require urgent establishment of the *causes* and *degrees* of *damages* and their *removal*.

Carbonation of concrete cover is also one of the causes of deterioration. By diffusion of *carbon dioxide* from the air to the surface layers of concrete, the *alkalinity* is decreased causing *depassivation* and the reinforcement *corrosion*. However, the process penetrates into the depth of concrete very slowly, and its progress can be easily established by measuring pH values.

CRACKS

The state of *cracks* is also an essential cause of concrete structures deterioration. In the cracked areas, the penetration of aggressive substances into the concrete is much easier.

It is indispensable to keep the real *width* of the cracks within the coded values. Cracks of lower width, frequently full of deposits of lime, dirt and rust, have significantly lower influence on the deterioration process.

During the *design*, it is necessary to analyze, as precisely as possible, the expected values of the crack widths. Through structural measures, concentration of stresses and the appearance of unexpected cracks should be avoided.



Unforeseen cracks arising during anchoring the prestressing tendons without necessary overlapping are shown in Figure 14.

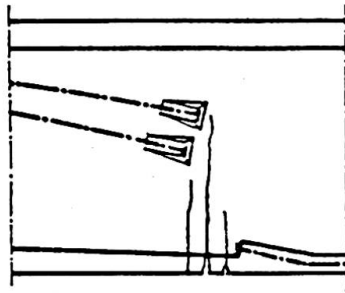

Fig. 14 - TENDONS ANCHORING WITHOUT OVERLAPPING

During the *construction* it is necessary to achieve the designed structure, with regards to the system, geometry, quality of the materials and of the executed works.

During the *operation*, the structure should be protected from overloading.

During the *maintenance*, it is necessary to regularly control the crack widths. If they are not within the design limits, the causes should be immediately established and removed, as well as the cracks of excessive widths sealed or injected.

REFERENCES

- /1/ Pakvor Aleksandar, Darijević Živojin: EXPERIENCES IN REHABILITATION AND REPAIR OF CONCRETE BRIDGES, IABSE Symposium "Maintenance, Repair and Rehabilitation of Bridges", Washington, DC, 1982, IABSE Reports, Volume 39, Zürich, 1982.
- /2/ DRAFT CEB-GUIDE TO DURABLE CONCRETE STRUCTURES, Contribution to the 24th Plenary Session of CEB, Rotterdam, 1985, CEB Bulletin d'Information 166, Lausanne, 1985.
- /3/ Pakvor Aleksandar: MAINTENANCE AS A FACTOR INFLUENCING THE REDUCTION OF CONCRETE STRUCTURES DETERIORATION, IABSE Working Commission VIII "Protection of Concrete Structures against Deterioration", Tokyo, 1986.
- /4/ Pakvor Aleksandar: MEASURES FOR MAINTENANCE OF CONCRETE STRUCTURES, IABSE Symposium "Concrete Structures for the Future", Paris-Versailles, 1987, IABSE Reports, Volume 55, Zürich, 1987.
- /5/ Pakvor Aleksandar, Đurđević Mihajlo: CAUSES OF DAMAGES AND REHABILITATION OF THE PANČEVO BRIDGE, Symposium IABSE "Durability of Structures", Lisbon, 1989, IABSE Reports, Volume 57/2, Zürich, 1989.
- /6/ Pakvor Aleksandar: MAINTENANCE, REPAIR AND REHABILITATION OF CONCRETE BRIDGES, International Conference on "Bridge", Ministry of Roads and Transportation and Amirkabir University of Technology, Tehran, 1990.
- /7/ Pakvor Aleksandar: DURABLE CONCRETE STRUCTURES, RILEM - IMECO Conference "Diagnosis of Concrete Structures", Bratislava, 1991.
- /8/ Pakvor Aleksandar: REHABILITATION AND RECONSTRUCTION OF CONCRETE STRUCTURES, ACI International Conference on "Evaluation and Rehabilitation of Concrete Structures and Innovations in Design", Hong Kong, 1991.