

# Lagerung gefährlicher Gase und Flüssigkeiten in Großbehältern

Autor(en): **Mang, Friedrich**

Objektyp: **Article**

Zeitschrift: **IABSE congress report = Rapport du congrès AIPC = IVBH  
Kongressbericht**

Band (Jahr): **14 (1992)**

PDF erstellt am: **22.06.2024**

Persistenter Link: <https://doi.org/10.5169/seals-853209>

## **Nutzungsbedingungen**

Die ETH-Bibliothek ist Anbieterin der digitalisierten Zeitschriften. Sie besitzt keine Urheberrechte an den Inhalten der Zeitschriften. Die Rechte liegen in der Regel bei den Herausgebern.

Die auf der Plattform e-periodica veröffentlichten Dokumente stehen für nicht-kommerzielle Zwecke in Lehre und Forschung sowie für die private Nutzung frei zur Verfügung. Einzelne Dateien oder Ausdrucke aus diesem Angebot können zusammen mit diesen Nutzungsbedingungen und den korrekten Herkunftsbezeichnungen weitergegeben werden.

Das Veröffentlichen von Bildern in Print- und Online-Publikationen ist nur mit vorheriger Genehmigung der Rechteinhaber erlaubt. Die systematische Speicherung von Teilen des elektronischen Angebots auf anderen Servern bedarf ebenfalls des schriftlichen Einverständnisses der Rechteinhaber.

## **Haftungsausschluss**

Alle Angaben erfolgen ohne Gewähr für Vollständigkeit oder Richtigkeit. Es wird keine Haftung übernommen für Schäden durch die Verwendung von Informationen aus diesem Online-Angebot oder durch das Fehlen von Informationen. Dies gilt auch für Inhalte Dritter, die über dieses Angebot zugänglich sind.

## Lagerung gefährlicher Gase und Flüssigkeiten In Großbehältern

Storage of Dangerous Gases and Liquids in Large Capacity Mounded Tanks

Stockage de gaz et liquides dangereux de grands réservoirs enterrés

**Friedrich MANG**  
Prof. Dr.-Ing.  
Universität (TH)  
Karlsruhe, Deutschland



Friedrich Mang, geboren 1934, promovierte an der Universität (TH) Karlsruhe als Bauingenieur. Er habilitierte auf dem Gebiet "Stahl- und Leichtmetallbau." Er arbeitet auf den Gebieten des Stahl- und anlagenbaues, der Werkstoffermüdung und der Verbindungstechniken

### ZUSAMMENFASSUNG

Für eingeeerdete Grossbehälter bis zu 8,50 m Durchmesser und bis zu 110 m Länge werden aus eigener Erfahrung Mitteilungen zur Ausführungsweise, Dimensionierung und zur Berechnung und Fertigung gemacht.

### SUMMARY

From own experiences, information is given on the design, dimensioning and the calculation, and fabrication of big storage vessels up to a diameter of 8.50 m and a length of 110 m.

### RÉSUMÉ

Nous donnons ces informations appuyées sur nos expériences personnelles quant à l'exécution, le dimensionnement, le calcul statique et la construction de grands réservoirs enterrés, dont le diamètre varie jusqu'à 8,50 m et la longueur jusqu'à 110 m.



## 1. TYPES OF FOUNDATION

For the foundation of big horizontal storage vessels for liquid gases with earth cover, the following types of foundation are possible:

a) continuous reinforced concrete foundation

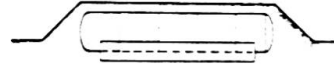

b) reinforced concrete saddles, possibly with piled foundation



c) sandbed storage

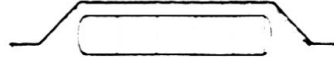

d) sandbed storage combined with an angular retaining wall

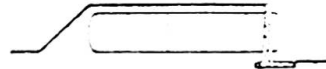

e) sandbed storage on a concrete rafter

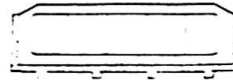

Fig. 1 Foundation methods

## 2. LOADING CASES

### 2.1 Summary of loading cases

During assemblage and transport of the vessel and installation into the sandbed, but particularly in the hydro testing and operational loading case, a variety of load components are to be considered:

Assemblage condition:	Dead weight
1st pressure test: (without earth cover)	Dead weight, water filling, test pressure differential settlements
Operation:	Dead weight, operational filling, design pressure, earth cover, traffic loads, differential settlements, temperature, friction, passive earth pressure on heads, vacuum, external explosion and earthquake (if applicable).
2nd pressure test: (with earth cover)	such as 1st test plus earth cover

### 2.2 Characteristic loading cases

The earth load ensued from the assumptions are presented in fig. 2. For the load assumption shown in fig. 2a, the radial component of the hydrostatic soil pressure on the shell has been taken into account. The figure 2b and 2c consider load increasing effects, which can result from settlements in the neighbourhood of saddle laid tanks (2b) or from arc action effects in the soil between tanks arranged closely together (2c).

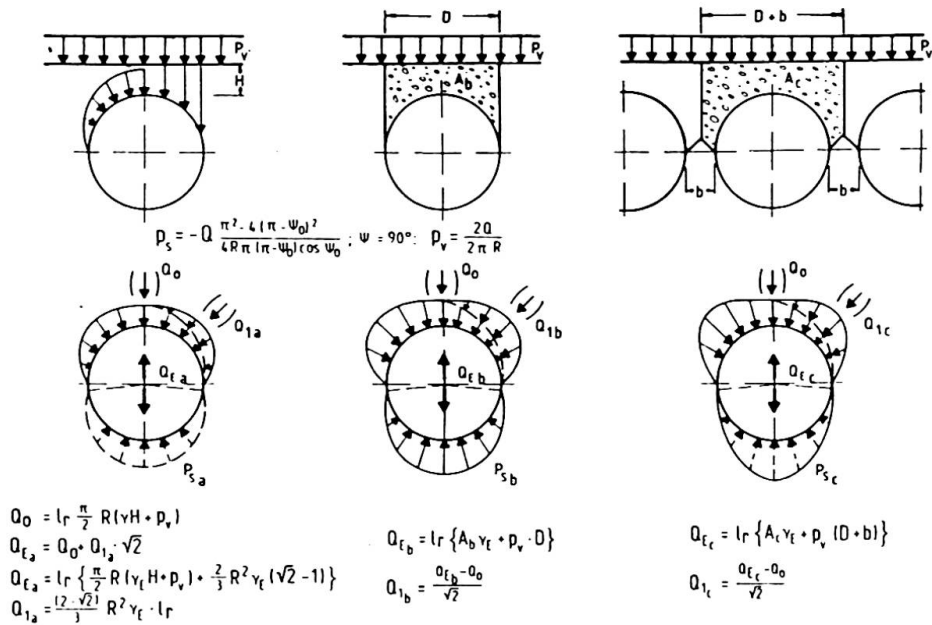

Fig. 2 Load assumptions for earth surcharge

For the assessment of the behaviour of earth covered cylinders upon earthquake loads, earthquakes are usually prescribed by the appropriate authority.

According to fig. 3, the bearing reaction occurs on a smaller surface so that the local soil pressure as well as the circumferential reactions increase. For this loading case, however, lower safety is required or rather higher stresses are allowed (for example according to BS 5500: +25%).

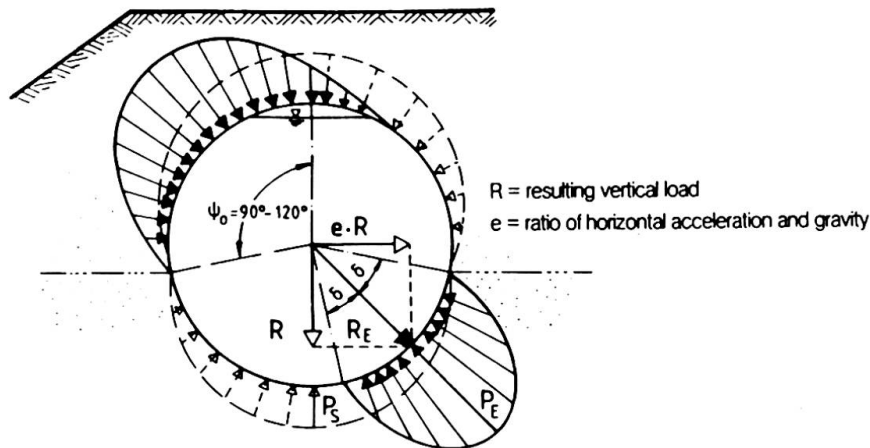

Fig. 3 Assumptions for earth covered load and bearing pressure in case of earthquake

### 3. STRESS INVESTIGATIONS

#### 3.1 Elastic foundation

The determination of the reactions related to the tank's longitudinal axis should be realized according to the theory of beams on elastic foundation for the various loading cases, considering the characteristic subsoil data, where the most unfavourable distribution of the bedding module due to differential settlements should be taken into account.

The governing reactions in circumferential direction have to be calculated in the cross section of the highest bearing pressure (see fig. 4)

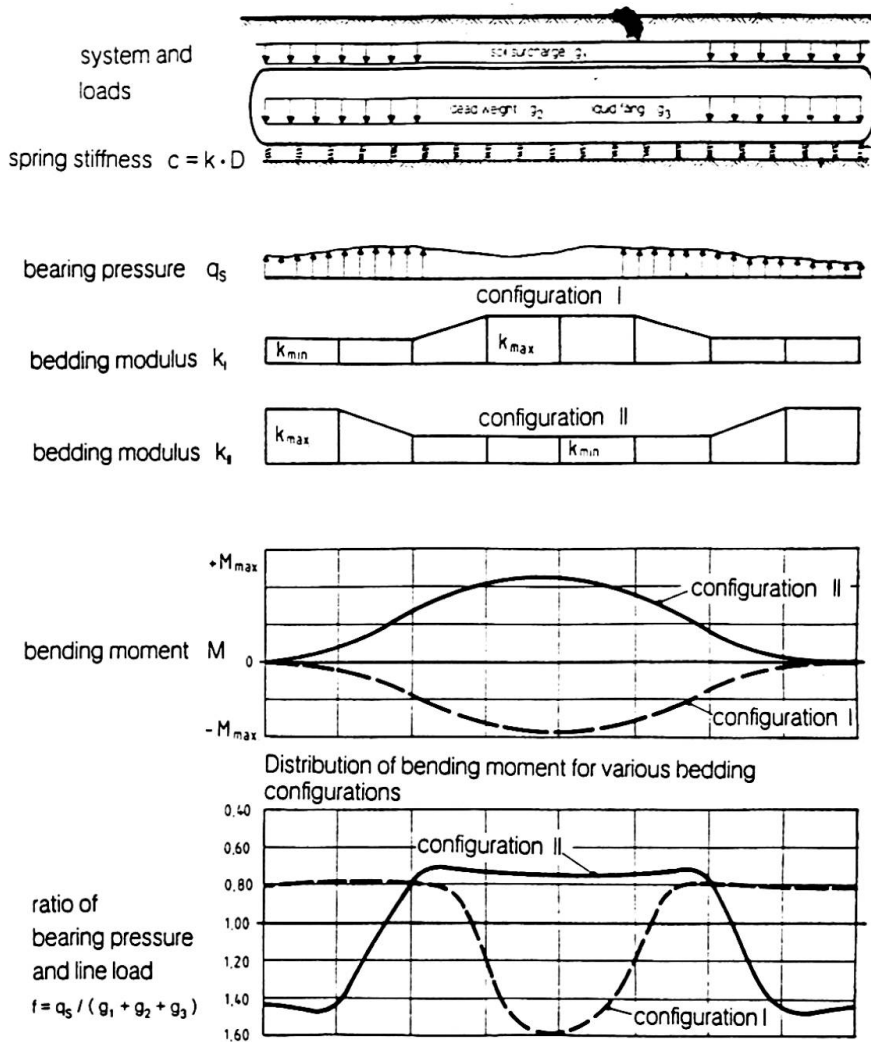

Fig. 4 Distribution of bending moment and bearing pressure for various bedding configurations

### 3.2 Stresses of secondary order caused by internal pressure

With internal pressure, the unstiffened shell area widens more compared to the ring stiffened region. The constraint developed in this way produces bending moments in the tank's longitudinal direction. The calculation of this secondary stress can be realized for example according to [1]. To this particular type of stress peaks, reference is made in British Standards 5500, App. A, as so-called "self-limiting" stress, e.g. the stress peak is reduced after yielding takes place. For this reason, BS 5500 allows stresses up to the double yield strength of this particular case.

## 4. INVESTIGATIONS INTO THE STABILITY

The external loadings from earth cover and bearing pressure, acting non-uniformly along the perimeter, have to be considered for buckling. Further, it can be required to consider underpressure in the investigation, which might occur due to a possible malfunction under service or human error.

The longitudinal bending loads between individual saddles or from uneven settlements in a sandbed as well as axial compression forces from friction and earth pressure on the heads necessitate also an investigation for the longitudinal direction.

The corresponding investigations on buckling can be carried out according to the relevant pressure vessel codes.

## 5. MANUFACTURING AND ASSEMBLING METHODS

### 5.1 Manufacturing and assembling of the steel structure

The manufacturing and assembling of horizontal cylindrical tanks with big diameters is usually carried out as pure site fabrication.

The distribution of sheets typical for this process of fabrication is presented in fig. 5.

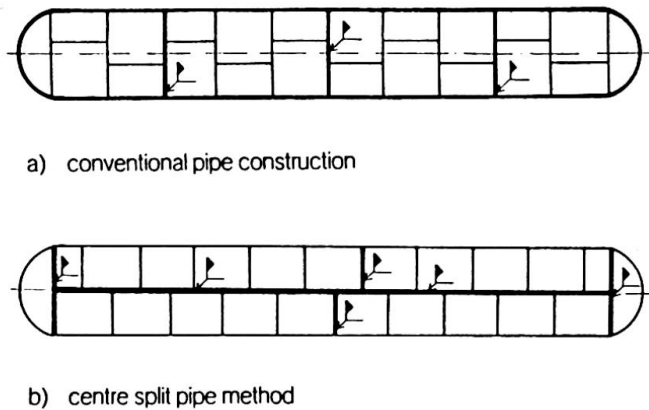

Fig. 5 Manufacturing methods

In order to reduce the work expenditure on site in favour of the fabrication in the workshop, the split pipe method has been selected for some projects. A typical course of the cuts is presented in fig. 6.

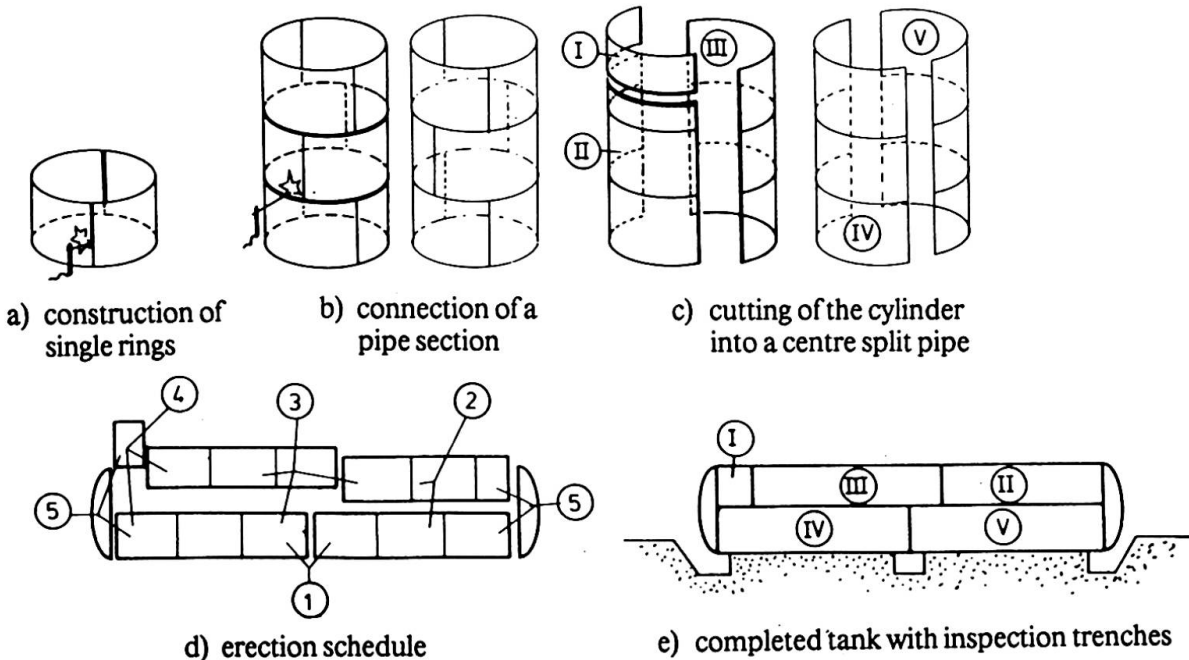

Fig. 6 Assembling course for the split pipe method

For the continuous position in a sandbed, accesses in the sandbed become necessary for fabrication and testing of the final seems (see fig. 6e).

After testing, these trenches cannot be compacted properly, and thus, form softer regions in the bedding. For this reason, possibly big units should be installed in order to limit the number of trenches. Recently, an



increasing number of tanks has been completely prefabricated in an assembly station on site or in the workshop.

A plan of the courses for the establishment of the earth cover is presented in fig. 7.

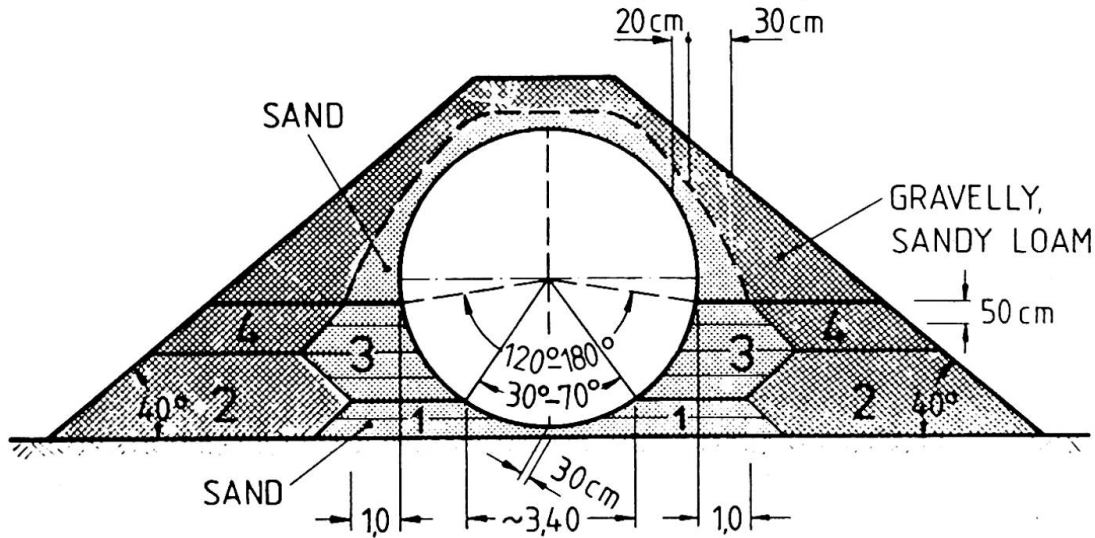

Fig. 7 Structure of layers for sandbed and earth cover

## 5.2 Quality assessment, performance test and control measures

When dimensioning new tanks, a welding factor of 1.0 is taken as a basis almost without exception. Therefore, each seam has to be subjected to 100% X-ray or ultrasonic proofs. These tests are done before the earth cover is installed. After a servicelife of 8-10 years, hydrotesting and weld inspections will be repeated (periodic testing).

Due to the settlement sensitivity of the tanks, which have partly a length of up to 100 m, it is recommended to monitor and record the settlement behaviour during hydrotesting and particularly under service in regular intervals.

## 6. REFERENCES

1. TIMOSHENKO, S., Theory of Plates & Shells, New York
2. MANG, F., Berechnung und Konstruktion ringversteifter Druckrohrleitungen. Springer Berlin, Heidelberg, New York 1966
3. MANG, F., Zur Gestaltung und wirklichkeitsnahen Bemessung von geschweißten ringversteiften Behältern und Rohren. Technische Mitteilungen Heft 9, 1973, p. 414 - 417.